

CHANGE DIMENSIONS AS NEEDED FOR CUSTOM TRAYS

| REV. NO. | | REVISIONS | DATE | APPROVED |
|----------|-------------|-----------|------|----------|
| DATE | DESCRIPTION | | | |
| | | | | |
| | | | | |

Precision Sheet Metal
 Design ♦ Engineering ♦ Fabrication
 www.acumetalfab.com

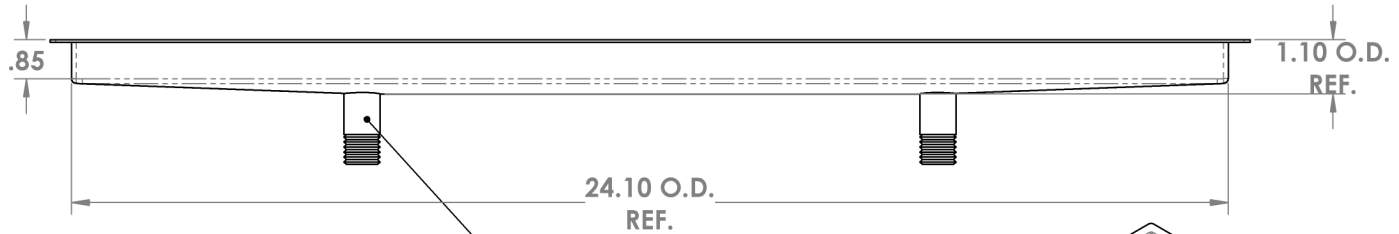
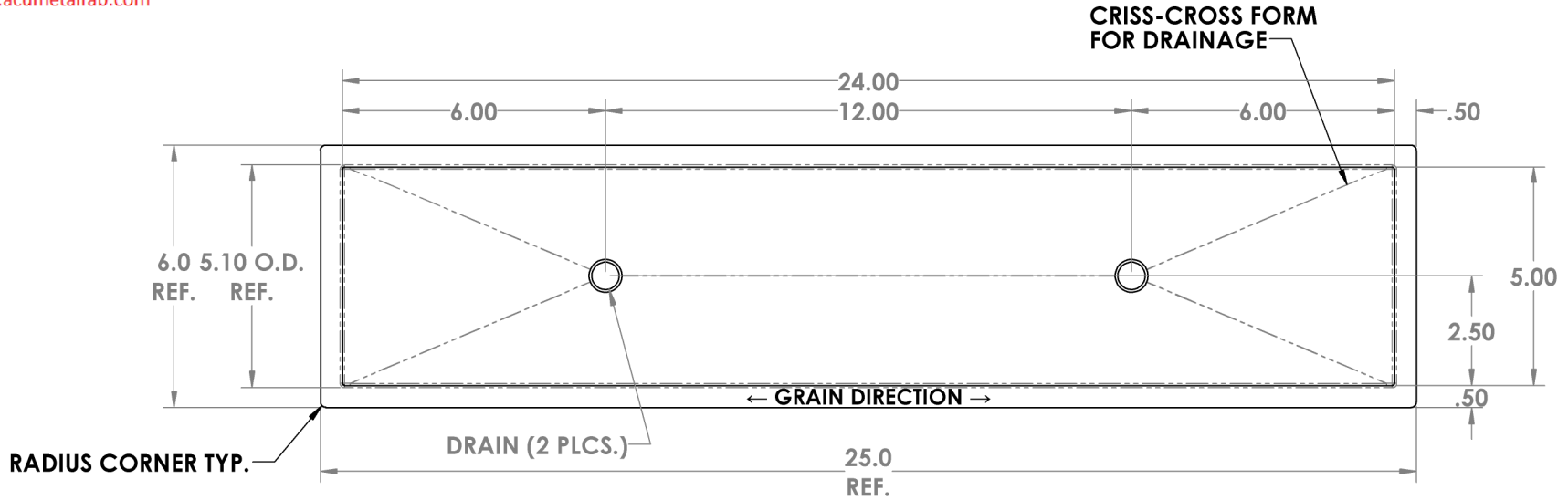

1/2" X 1 1/2" LONG
 NPT PIPE THREAD
 (2 PLCS.)

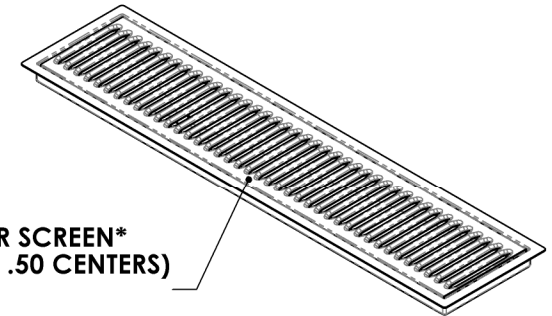

20 GA. LOUVER SCREEN*
 (3.50 X .50 ON .50 CENTERS)
 STANDARD

PART # 0200-24-2

NOTES:

ALL DIMENSIONS ARE INSIDE DIMENSIONS
 (UNLESS OTHERWISE NOTED)

* OPTIONAL 18 GA. PERFORATED SCREEN
 AVAILABLE ON CUSTOM TRAYS

www.acumetalfab.com

PROPRIETARY AND CONFIDENTIAL

THE INFORMATION CONTAINED IN THIS
 DRAWING IS THE SOLE PROPERTY OF
 ACU PRECISION SHEET METAL. ANY
 REPRODUCTION IN PART OR AS A WHOLE
 WITHOUT THE WRITTEN PERMISSION OF
 ACU PRECISION SHEET METAL IS
 PROHIBITED.

ACU PRECISION SHEET METAL IS :
 AMERICAN COFFEE URN MANUFACTURING CO., INC

| | NAME | DATE |
|----------|----------------------------|-------|
| DRAWN | L. WILLIAMS | 05/17 |
| MATERIAL | 18 GA. 304 STAINLESS STEEL | |
| FINISH | #4 BRUSHED | |

DO NOT SCALE DRAWING

| TITLE: |
|---|
| FM-DD FLUSH MOUNT W/DBL. DRAIN 5" X 24" |
| AMERICAN COFFEE URN |