

CHANGE DIMENSIONS AS NEEDED FOR CUSTOM TOWERS

		REVISIONS			
ZONE	REV.	DESCRIPTION	DATE	APPROVED	

Precision Sheet Metal
 Design ♦ Engineering ♦ Fabrication
 www.acumetalfab.com

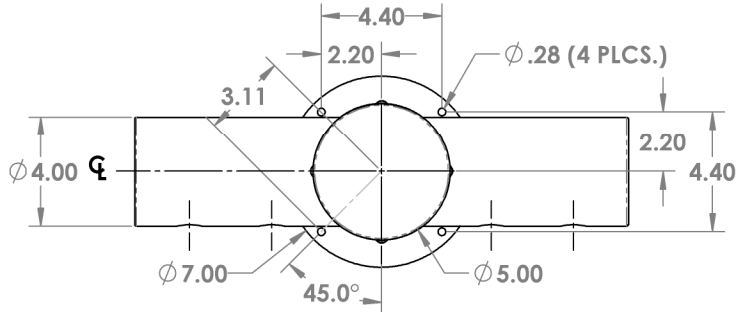

8-32 X .375" TRUSS HEAD SCREW (8 PLCS.)

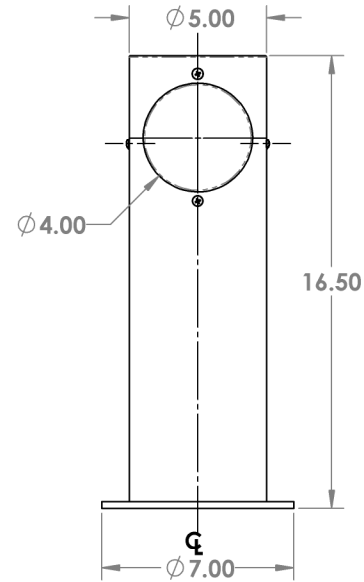
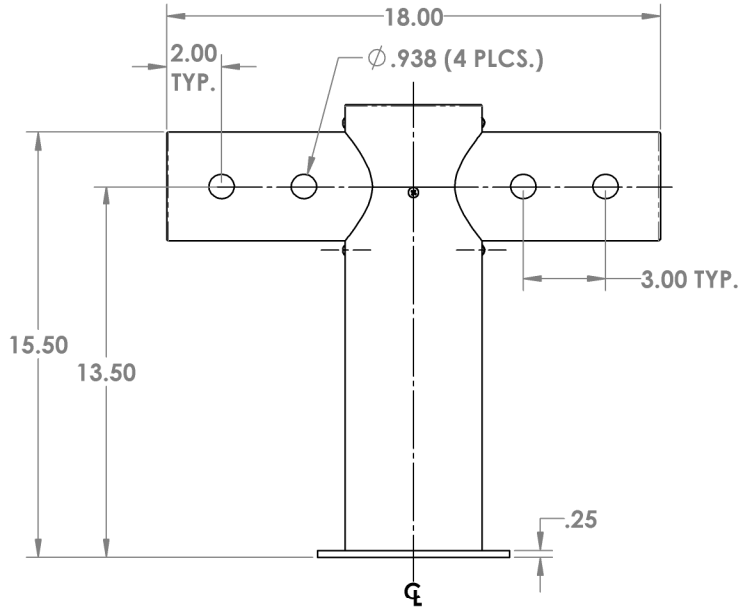
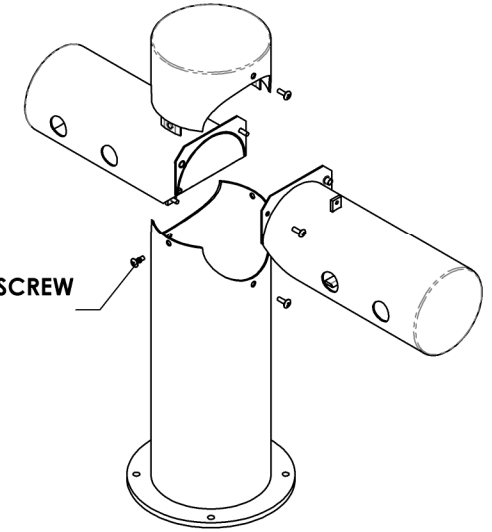

NOTES:

ALL DIMENSIONS ARE OUTSIDE DIMENSIONS (UNLESS OTHERWISE NOTED)

MATERIAL:

- Ø 4.00 X .06 WALL 304 STAINLESS STEEL TUBE
- Ø 5.00 X .06 WALL 304 STAINLESS STEEL TUBE

www.acumetalfab.com

PROPRIETARY AND CONFIDENTIAL
 THE INFORMATION CONTAINED IN THIS DRAWING IS THE SOLE PROPERTY OF ACU PRECISION SHEET METAL. ANY REPRODUCTION IN PART OR AS A WHOLE WITHOUT THE WRITTEN PERMISSION OF ACU PRECISION SHEET METAL IS PROHIBITED.
 ACU PRECISION SHEET METAL IS :
 AMERICAN COFFEE URN MANUFACTURING CO., INC

	BASE TUBE	81026-08
	TOP TUBE	81026-20
	RIGHT TEE TUBE	81026-10
	LEFT TEE TUBE	81026-11
	NAME	DATE
DRAWN	L. WILLIAMS	03/18
MATERIAL	SEE NOTES	
FINISH	#8 POLISHED	

PART # 81026-T18

TITLE:	
4 X 5 METRO TEE TOWER 4 HOLE, 18" TEE TOWER	
AMERICAN COFFEE URN	