

REV. NO.		REVISIONS	DATE	APPROVED
ZONE	REV.	DESCRIPTION		

**Precision Sheet Metal**  
 Design ♦ Engineering ♦ Fabrication  
 www.acumetalfab.com

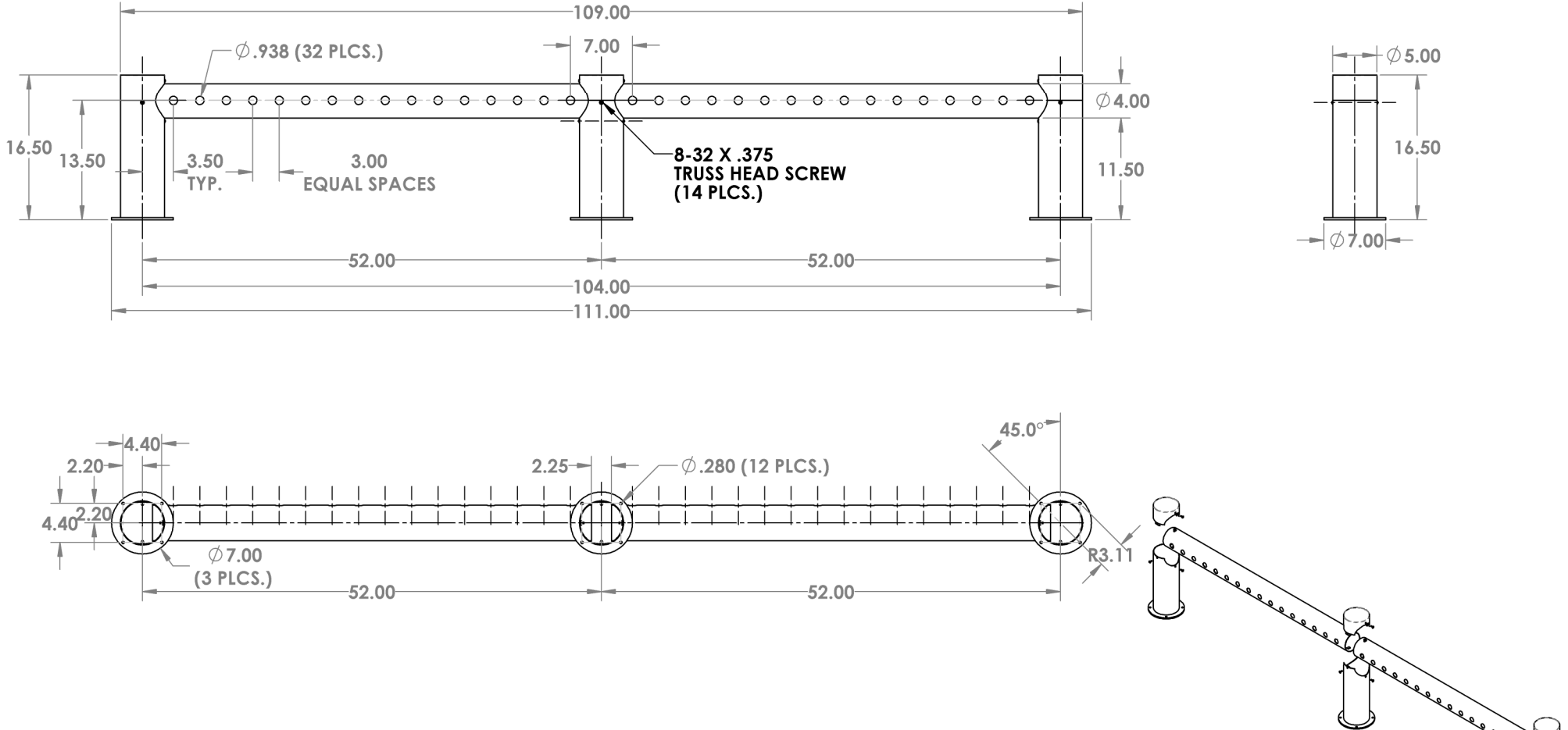

**NOTES:**

**ALL DIMENSIONS ARE OUTSIDE DIMENSIONS (UNLESS OTHERWISE NOTED)**

**MATERIAL:**

- $\phi$  4.00 X .06 WALL 304 STAINLESS STEEL TUBE
- $\phi$  5.00 X .06 WALL 304 STAINLESS STEEL TUBE

1 EA.	CENTER BASE TUBE	41025-08
1 EA.	CENTER TOP TUBE	41025-20
2 EA.	END BASE TUBE	41025-01
2 EA.	END TOP TUBE	41025-02
2 EA.	CROSS TUBE	41025-07

**PART # 41025-MT109**

PROPRIETARY AND CONFIDENTIAL  
 THE INFORMATION CONTAINED IN THIS DRAWING IS THE SOLE PROPERTY OF ACU PRECISION SHEET METAL. ANY REPRODUCTION IN PART OR AS A WHOLE WITHOUT THE WRITTEN PERMISSION OF ACU PRECISION SHEET METAL IS PROHIBITED.  
 ACU PRECISION SHEET METAL IS :  
 AMERICAN COFFEE URN MANUFACTURING CO., INC

	NAME	DATE
DRAWN	L. WILLIAMS	07/18
MATERIAL	SEE NOTES	
FINISH	#4 BRUSHED	

TITLE:
<b>4 X 5 METRO TOWER 32 HOLE, 109" M-TOWER</b>
<b>AMERICAN COFFEE URN</b>