

CHANGE DIMENSIONS AS NEEDED FOR CUSTOM TOWERS

REV. NO.		REVISIONS	DATE	APPROVED
DATE	BY	DESCRIPTION		

Precision Sheet Metal
 Design ♦ Engineering ♦ Fabrication
 www.acumetalfab.com

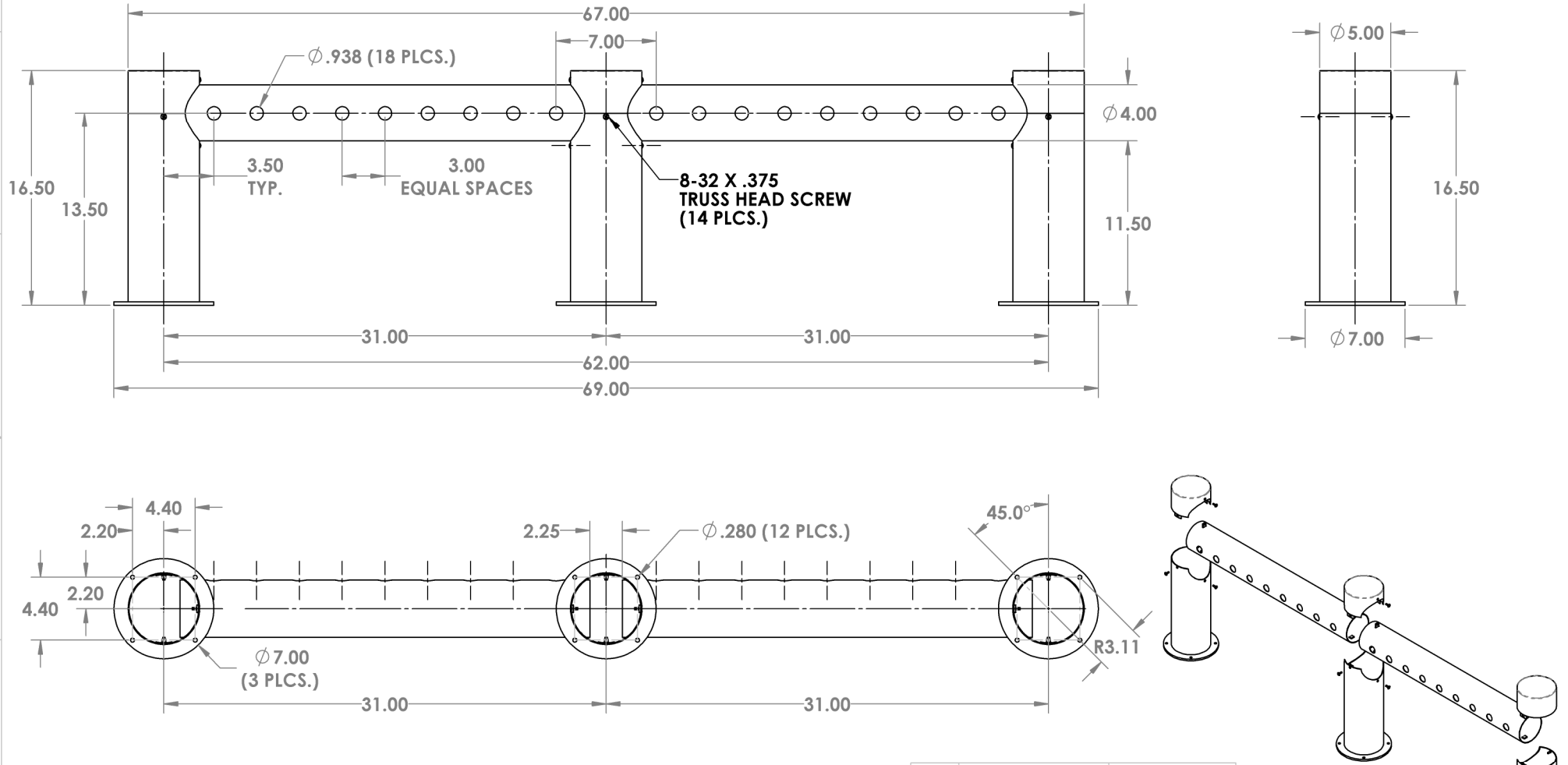

NOTES:

ALL DIMENSIONS ARE OUTSIDE DIMENSIONS (UNLESS OTHERWISE NOTED)

MATERIAL:

- $\phi 4.00$ X .06 WALL 304 STAINLESS STEEL TUBE
- $\phi 5.00$ X .06 WALL 304 STAINLESS STEEL TUBE

1 EA.	CENTER BASE TUBE	81026-08
1 EA.	CENTER TOP TUBE	81026-20
2 EA.	END BASE TUBE	81026-01
2 EA.	END TOP TUBE	81026-02
2 EA.	CROSS TUBE	81026-24

PART # 81026-MT67

PROPRIETARY AND CONFIDENTIAL
 THE INFORMATION CONTAINED IN THIS DRAWING IS THE SOLE PROPERTY OF ACU PRECISION SHEET METAL. ANY REPRODUCTION IN PART OR AS A WHOLE WITHOUT THE WRITTEN PERMISSION OF ACU PRECISION SHEET METAL IS PROHIBITED.
 ACU PRECISION SHEET METAL IS : AMERICAN COFFEE URN MANUFACTURING CO., INC

	NAME	DATE
DRAWN	L. WILLIAMS	07/18
MATERIAL	SEE NOTES	
FINISH	#8 POLISHED	

TITLE:
4 X 5 METRO TOWER 18 HOLE, 67" M-TOWER
AMERICAN COFFEE URN