

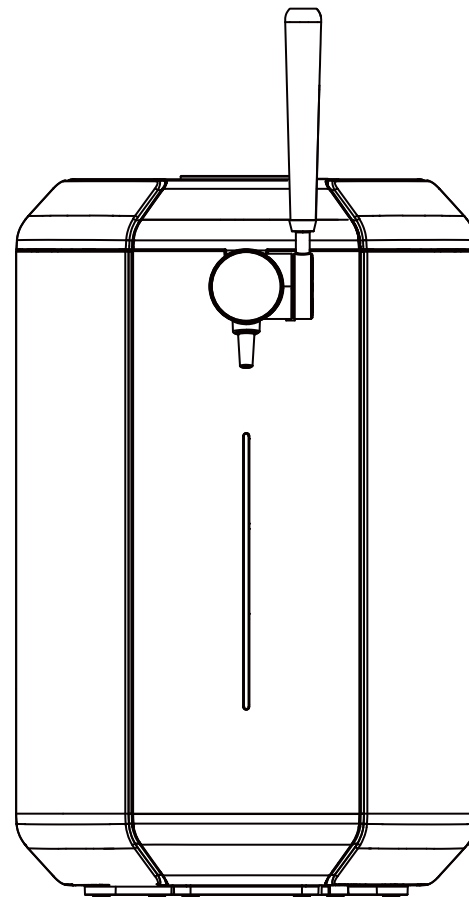

iGulu (Shenzhen) Intelligent Technology Co., Ltd.
www.igulu.com

iGulu F1



iGulu F1 Smart Beer Home Brew Appliance

Instruction Manual

Contents

1. Safety	1		
2. Product Overview	4		
a. Product Specifications and Configuration	4		
b. Package Contents	5		
c. Component Diagrams	6		
3. General Operations	7		
a. Machine Installation	7		
b. Usage of CO ₂ Cylinder and Pressure Reducing Valve	9		
c. Change of Tap Handle and Spout Cleaning	10		
d. Usage of Tube Clamp	11		
e. Ambient Light	11		
4. Display Screen and Control Panel	12		
a. Starting-up	12		
b. Function Selection	12		
c. Connecting to Wi-Fi	13		
d. Resetting Wi-Fi	13		
e. Introduction of APP	13		
f. iGulu Premium	13		
5. Fermentation Mode	14		
a. Getting Started	14		
b. Selecting Fermentation Programs	15		
· Initiating Fermentation Process via RFID	15		
· Initiating Fermentation Process via Control Panel (for Premiums Only)	16		
· Initiating Fermentation Process via App (for Premiums Only)	18		
c. Enjoying Fresh Beer	19		
d. Cleaning and Sanitizing the Keg and its Accessories	19		
6. Cooling & Dispensing Mode	20		
a. Gas-free Mode	20		
· Compatible Illustration	20		
· Installation	20		
· After Use	22		
b. CO ₂ Mode	22		
· Compatible Illustration	23		
· Installation	23		
· After Use	27		
c. Air Pump Mode	28		
7. Cleaning and Sanitizing	28		
a. Cleaning and Sanitizing the Keg and its Accessories	28		
b. Cleaning and Sanitizing the Machine	30		
8. Troubleshooting	31		
a. Troubleshooting Table	31		
b. Operating Error Popups	32		
c. Machine Error Popups	33		
Statement	34		
Order the Accessories and Recycle	35		
Warranty Card	36		

1. Safety Instructions

Your iGulu F1 is designed and manufactured with the highest safety level. To ensure your safety and excellent usage experience, please read this manual carefully before use. If you have any questions, please contact iGulu after-sales support.

Contact: 4008282861

E-mail: contact@igulu.com

Website: www.igulu.com

Danger

- Do not use CO₂ cylinder when the surrounding temperature reaches 49°C/120 °F.
- Do not store flammable and explosive materials, such as combustion promoter and spray, in the machine.

Warning

- Do not disassemble this machine for any reason.
- Do not use the machine for anything other than what it has been designed for.
- Do not immerse this machine or the plug in water or other liquids, nor rinse it under the tap.
- Do not operate the machine directly in the sun.
- If the SUPPLY CORD is damaged, it must be replaced by a special cord or assembly available from the manufacturer or its service agent.

Caution

- Before connecting the product to power, check if the voltage of the machine matches the local supply voltage.
- The machine must be plugged into a grounded socket and make sure the plug is firmly inserted.
- Compressor inside, please keep the machine upright.
- Use the machine on a cool and dry place.
- Place the machine on a flat surface for use.
- Keep the machine away from children and pets.

- Lift and transport the machine with care. When moving, make sure to stop using the machine and unplug the power plug.
- Before use, check if the power cord is damaged. If yes, replace it promptly and do not use it.
- Do not use this machine if the plug, or the product itself is damaged.
- Connect the power supply or touch the switch with dry hands.
- Ensure that the machine is at least 10cm/4in away from walls and other objects during use.
- Do not pour water, spray and other liquids into the tap or inside the machine during use.
- To avoid affecting the normal use of the machine, it is prohibited to put other kegs or items other than those mentioned in the "Compatible Illustration" .
- Do not remove the keg until it is empty.
- Do not unplug the power plug while the device is running, or turn the machine on or off by directly controlling the power plug.
- Cut off the power supply when not using the machine.
- Unplug the machine before you clean or repair it.
- Do not leave the machine outdoors for prolonged use.
- Use only the accessories and spare parts provided by iGulu.
- Ensure all vents are free of obstructions.
- Dispose of discarded packaging materials properly.
- Do not start the machine when it is empty or improperly placed with the iGulu keg, or other types of 5L keg. Please follow the on-screen prompts and refer to the instruction manual to put in the keg correctly before operation.
- Please use this product according to the instructions in the manual. Any loss or injury caused by improper use shall be the responsibility of the user.

Safety Precautions for the Keg

During fermentation, a large amount of gas will be generated, and the pressure range of the keg is 0-200 kPa (0-2 bar; 0-29 psi) under normal circumstances. You must follow the correct operation method stated in this manual, otherwise there exists a risk of Keg Explosion!

1. Do not directly expose the keg and its accessories to the sun to avoid reducing their service life.
2. Make sure that the clamping ring is properly installed on the keg, so that the keg lid is fastened onto the keg body.

3. Make sure to buckle the clamping ring up.
4. Make sure that the safety valve spool moves smoothly.
5. When the valve spool is stuck by beer or foreign objects, or other abnormal conditions occur, do clean the valve spool in time or replace the safety valve so that the gas can be discharged from the keg body.

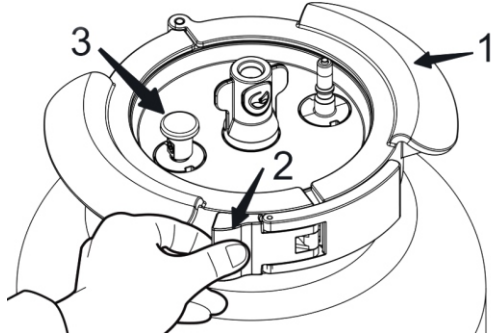

Safety Precautions for Off-the-shelf Beer Kegs

This product is compatible only with the standard draught kegs (mostly German-style 5L kegs, refer to the “Compatible Illustration” in the Cooling & Dispensing Mode for details) which is common on the market, or other kegs provided by iGulu. The following are some precautions when using the Off-the-shelf Beer Kegs:

1. Please check whether the keg is damaged or has exceeded its service life before use. If the above conditions exist, please do not use it.
2. Thoroughly understand the safety and storage information of the kegs you want to use for this machine.
3. If there is damage to the upper surface of a keg with a Pressure Relief Valve, the AS Dispensing Coupler may not be inserted properly, or beer can not run smoothly out of the tap.
4. It is best to refrigerate the keg for 1-5 hours before placing it in the machine. But do not put the keg into the freezer, otherwise it will cause damage to the keg.
5. Do not shake the keg before use.
6. To avoid high-temperature explosions, store the purchased draught kegs in a shaded area. Do not expose them directly to the sun or the environment of temperatures above 30 °C.

7. There is pressure inside the kegs, do not pierce the keg with sharp objects.
8. The 5L Heineken keg is equipped with a small CO₂ pressure system. Do not remove its top parts, as other draught kegs with built-in pressure systems are the same.
9. When using the Off-the-shelf Beer Keg for cooling, carefully read the “Installation” instructions for the kegs in Cooling & Dispensing mode.

2. Product Overview

Product Specifications and Configurations

Specification Table

Product Name	Beer Fermenter and Cooler	
Model	iGulu F1	
Capacity	5L	
Voltage	100-240V~	
Frequency	50/60Hz	
Cooling Power	12V=60W, 5A	
Heating Power	12V=13.2W, 1.1A	
Climate Type	N/SN	
Adjustable Temperature Range	Cooling: 2~12°C	Brewing: 2~30 °C
Cooling Method	DC Compressor	
Refrigerant	R-513A (34g)	
Vesicant	Cyclopentane	
Gas Source	CO ₂ Cylinder or Air Pump	
Product Sizes	332*455*518mm (Tap Handle and Drip Tray excluded)	
Net/Gross Weight	11.3kg (Cylinder excluded) /15kg	
Packaging Dimensions	485*372*640mm	

Special Configuration

Display Screen	√	Keg Absence Detector	√
WiFi	√	Beer Temperature Monitor	√
Bluetooth	√	RFID	√
Pressure Indicator	√	Gas Supplement with Air Pump	√
Power Memory	√	Ambient Light	√

Package Contents

Brewing Machine	x1	Dispensing Tube	x2
Power Adapter	x1	Tap Handle	x1
iGulu Keg	x1	Spout	x1
AS Dispensing Coupler	x1	Drip Tray	x1
AT Dispensing Coupler	x1	Instruction Manual	x1

Product Diagrams

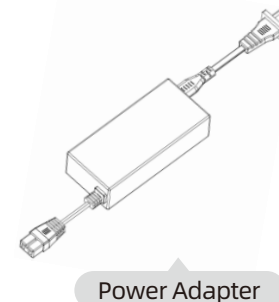
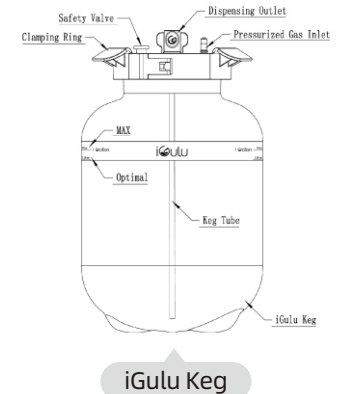
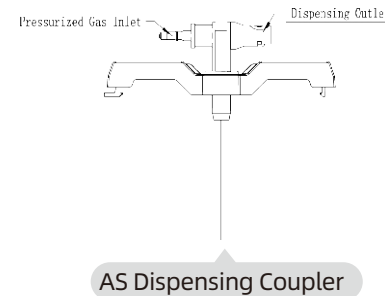
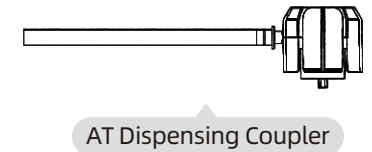
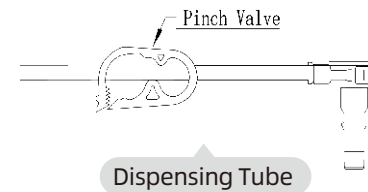
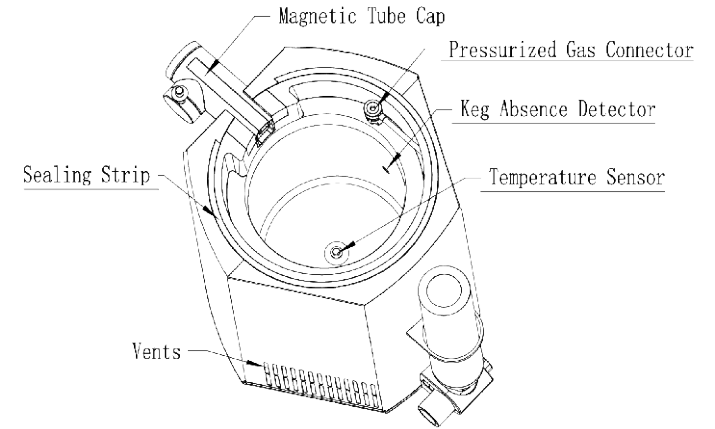
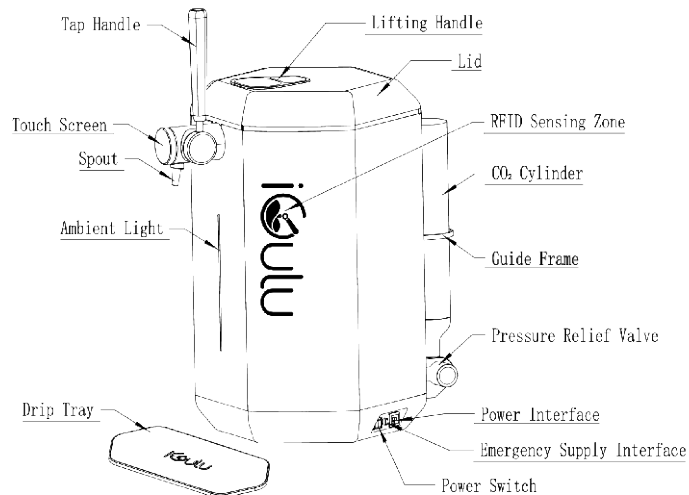

Note: The product, accessories, user interface, and other illustrations in the manual are schematic diagrams for reference only. Due to product updates and upgrades, there may be differences between the actual product and the schematic diagram. Please refer to the actual product for details.

3. General Operations

As this product contains a compressor, you can not start using it until you leave it for at least 2 hours after unpacking.

Machine Installation

① Placing the machine

When moving, use safe techniques, such as holding the bottom of the machine. Never lift it with the guide frame of CO₂ cylinder at the back of the machine to avoid any occurrence of damage.

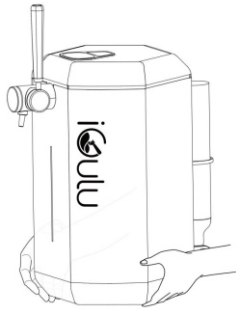

Correct Way of Movement

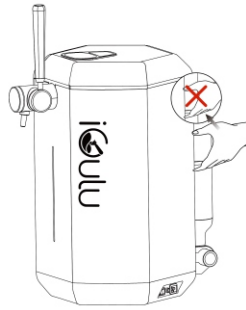

Wrong Way of Movement

For the best performance of the machine, ensure that the machine is at least 10cm or 4 in. away from walls and other objects.

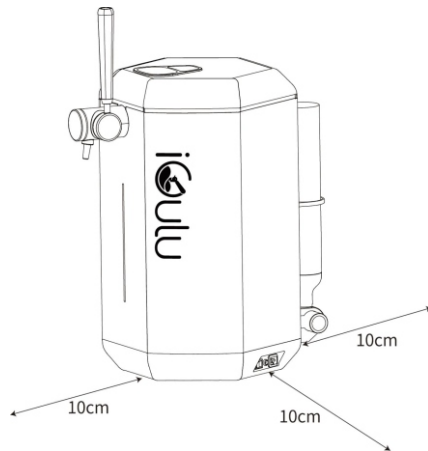

② Connecting the Power Adaptor

Please use the power adaptor provided by iGulu. It may cause device malfunction, restart, or other abnormal situations to use non-original power adaptor.

The power interface on the machine is located at the bottom on the right side of it (when you face the screen), please pay attention to the pointing direction of the plug.

You can also use an Emergency Power Supply (EPS) that meets the following specifications with the Type-C charging cable dedicated to iGulu devices to power the machine when there is a power outage or when using the product outdoors.

- The EPS needs to be equipped with a Type-C output interface that supports the USB Power Delivery, and its output value meets DC12V.
- The Type-C charging cable can be purchased on the iGulu website: www.igulu.com.

Usage:

Use a Type-C charging cable, with one end plugged into the Type-C interface of the EPS and the other end plugged into the Emergency Supply Interface (a circular socket) in the middle of the bottom of the machine.

Caution:

- Do not cover any objects on the machine and power adaptor when using.
- When using the EPS for charging, the machine can not start the Cooling & Dispensing Mode or Fermentation Mode, only be used for dispensing with an air pump.

③ Turning on the Power Switch

Switch power to “-” , and the machine will be powered on and ready for operation.

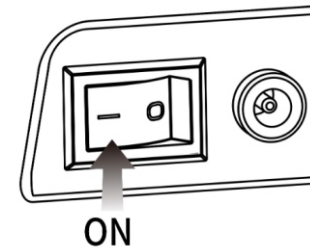

Usage of CO₂ Cylinder and Pressure Reducing Valve

You can use CO₂ cylinder as the gas source for the machine.

First, remove the Dust Cap from the Pressure Reducing Valve. Then screw the cylinder clockwise into the Pressure Reducing Valve at the rear of the machine, ensuring that the cylinder is fastened.

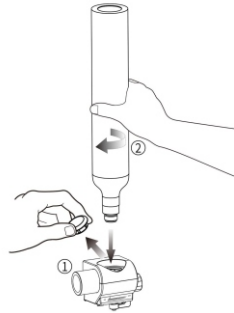

Then turn on the Pressure Reducing Valve Switch clockwise, observing whether the number of the Pressure Gauge reaches a certain pressure value. When it reaches a stable value, that means the cylinder has been properly installed.

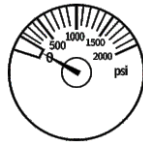
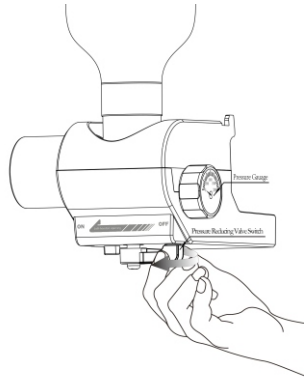

Point to "0" :

- 1) No gas cylinder is installed.
- 2) Gas is exhausted and needs to be replaced with a new cylinder;
- 3) The switch is not fully turned on.

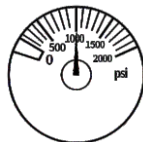

Point to "a right reading" :

The cylinder is correctly installed with sufficient gas.

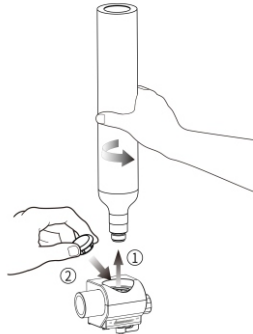

When you need to remove the cylinder, please first turn off the Pressure Reducing Valve Switch; then screw the cylinder counterclockwise to remove it, with the Dust Cap installed back in place.

Cautions:

1. The machine must be suitable for the cylinder with a pressure range of 0-7 Mpa (0-70 bar /0-1015 psi) in the 25°C room temperature. To ensure your safety, please do not use unqualified CO₂ cylinders or gases. It is recommended to purchase CO₂ cylinders with the following markings printed on the cylinder body.

Note: The cylinder should meet the American standard DOT-3AL1800. The CO₂ gas should be food-grade safe.

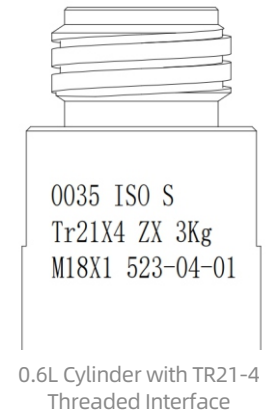

2. You can purchase compatible CO₂ cylinders from the official iGulu website. Empty cylinders can be refilled through authorized channels.
3. When no CO₂ cylinder is installed, please install the Dust Cap in place to ensure that no foreign objects enter the Pressure Reducing Valve.
4. Only use clean water and a soft cloth to wipe the Pressure Reducing Valve.
5. In case of any malfunction or damage, please contact iGulu after-sales.
6. To ensure your safety, please only open the Pressure Reducing Valve Switch when using CO₂ as the gas source. In other cases, please keep the Pressure Reducing Valve closed.

Change of Tap Handle and Spout Cleaning

The tap handle and spout of the machine are designed to be detachable. You can unscrew the handle counterclockwise and replace it with your preferred handle.

Before and after each use, we recommend removing the spout in the direction shown in the diagram for cleaning. To install the spout, simply insert it back in the opposite direction.

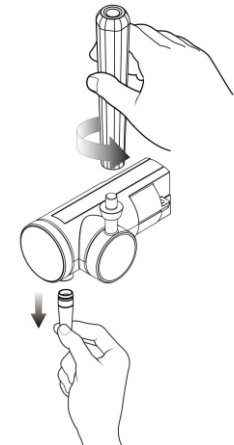

Usage of Pinch Valve

To prevent accidental splashing of liquor due to improper operation sequence, the Dispensing Tube provided from iGulu comes with a pinch valve. Please close the pinch valve when using the Dispensing Tube.

The pinch valve has multiple gearing teeth. You can control the flow of the beer by adjusting the position of the gear, which can help reduce the generation of foam when dispensing.

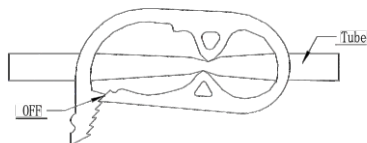

The Closed Pinch Valve

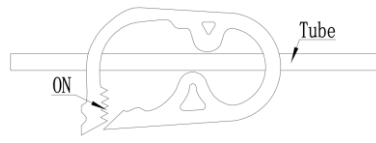

The Open Pinch Valve

Ambient Light

The machine is equipped with ambient lights. You can instantly determine the working status of it based on the color of the lights.

Color of Ambient Light	Orange	Green	White	Lightless
Brewing Status	Fermenting	Cooling	Standby	Turned Off

4. Display Screen and Control Panel

When operating the screen, please keep the touch screen and fingers clean and dry to avoid affecting the normal use of the screen!

Starting-up

Connect the power and ground, turn on the power at the bottom. The machine will start up and a list of functions is displayed on the screen, with the WiFi and Bluetooth icons at the top showing whether the machine is connected to the network or Bluetooth.

Function Selection

You can access all the functions of the machine by sliding your finger up and down on the screen, such as Fermentation, Cooling, History, Settings, etc.

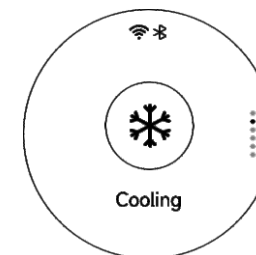
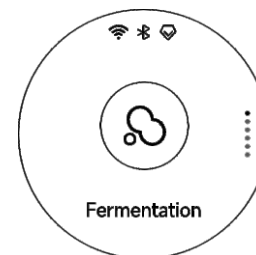

Tap on the function icon to enter the corresponding function page, and view more informations by sliding. If you need to return to the previous page, just swipe right.

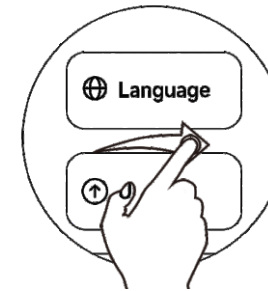
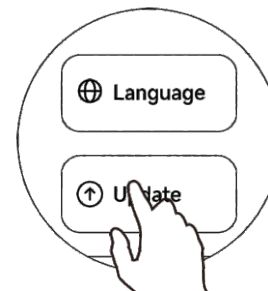

Connecting to Wi-Fi

The machine will automatically enter the Wi-Fi connection status after the first power. Please download and open the iGulu App to set up the Wi-Fi network.

Resetting Wi-Fi

When you change the router, Wi-Fi password or the current Wi-Fi is unstable, you need to reset the Wi-Fi. In standby mode, swipe the menu to switch to "Settings". Tap on the menu, slide up and down to see the "Reset", and then tap on "Reset" to reset Wi-Fi.

Connecting iGulu App

This product has now been connected to the iGulu App, and users can control it in real-time through the iGulu client.

Scan the QR code, download and install "iGulu". Users who have already installed it can ignore this step and proceed directly to the next step.

Open the homepage of the App, click "Add Device" in the middle of the page, and add the device according to the App prompts.

"iGulu" Client



For more information log in to the iGulu APP

Note: With the upgrade of iGulu App, the content of the App may change. Please refer to the actual operation of the App for details.

iGulu Premium

Unlocking more professional brewing functions, such as some of Craft and Fermentation, requires upgrading the machine to the Premium edition.

Note: If you need to upgrade your machine to the Premium edition, you can purchase it on the iGulu APP or iGulu website.

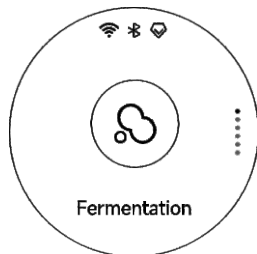

13

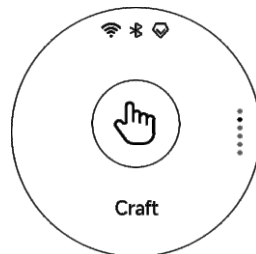

5. Fermentation Mode

Getting Started

① Cleaning and Sanitizing the Machine

Clean and sanitize the keg and its accessories with appropriate methods to clean.

② Adding Ingredients

According to the instructions on the ingredient kit, add the brewing ingredients in sequence. Please pay attention not to exceed the maximum line.

Note: You can purchase ingredient kits on the iGulu website or the iGulu App.

③ Installing the Keg

1. Put the keg lid onto the keg.

2. Fasten the keg tightly with the clamping ring, and please ensure the ring is installed in place!

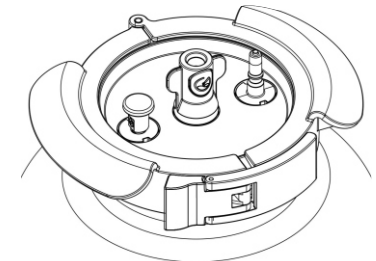
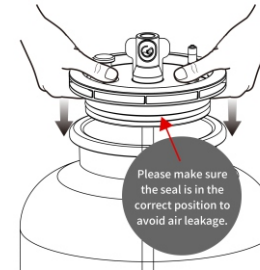

④ Assemble of Tubes

1. Remove the lid and put the keg into the machine;

2. Remove the magnetic tube cap in the direction indicated by the diagram;

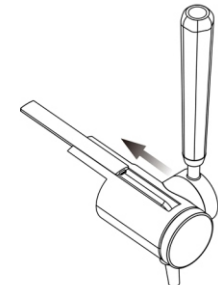
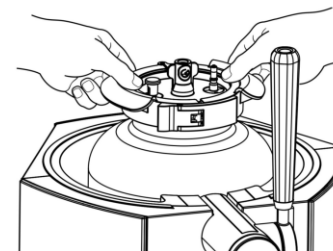

14

3. Pull the tap handle to its full extent and insert the iGulu tube into the faucet until it cannot not be inserted;

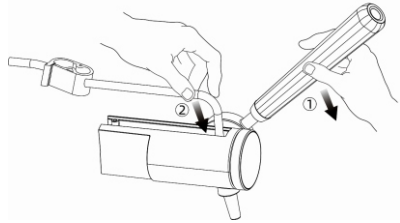

4. Insert the plug of the Dispensing Tube into the Dispensing Outlet on the keg to allow the beer to flow out;

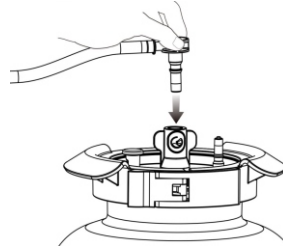

5. Plug the Pressurized Gas Connector into the Pressurized Gas Inlet of the keg;

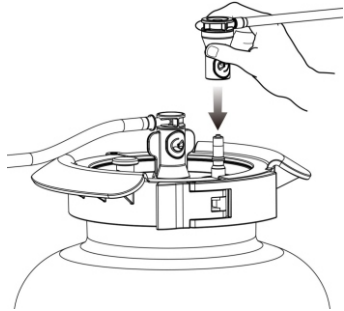

6. The following is a schematic diagram of the completed connection of the pipeline. Finally, install the Magnetic Tube Cap and Keg Lid.

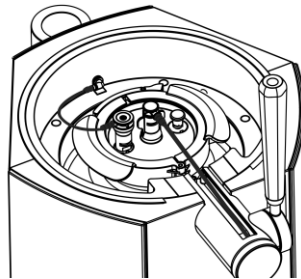

Selecting Fermentation Programs

There are three methods at your disposal to start the fermentation process, and once initiated, the color of the ambient lighting shall become a warm shade of orange.

① Initiating Fermentation Process via RFID

- Each iGulu ingredient kit comes with a unique RFID smart card.



- Place the RFID card on the designated spot—RFID Sensing Zone, as shown in the diagram below, to activate the RFID chip recognition mode.

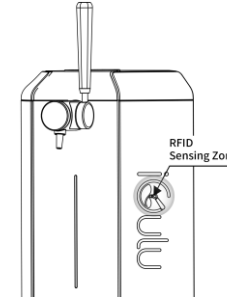

- After the RFID card is activated, press “Next” on the screen to get the fermentation recipe.

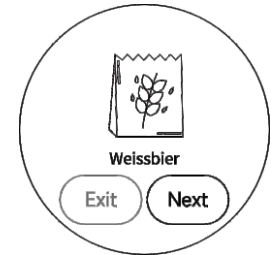

- Initiate the fermentation process by tapping on “Brew” .

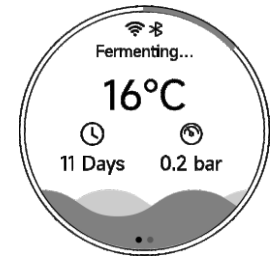
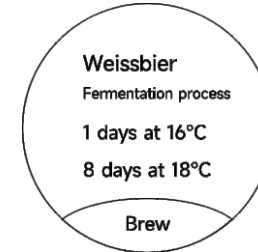

② Initiating Fermentation Process via Control Panel (for Premiums Only)

Press the “Fermentation” in the function list, and you will be directed to the page of fermentation programs.

- You can view all the processes available on your current machine on the page of the fermentation programs.

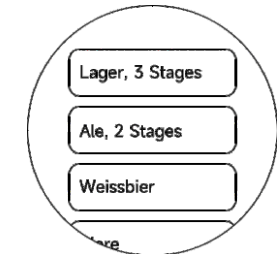
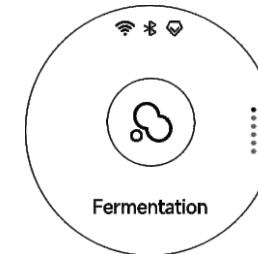

For example, you may choose the process of “Weissbier” to access the “BREW” page.

- On the page of “BREW” , you can swipe left (swipe right to return) to view more fermentation details, such as the temperature and duration for each step of the process.

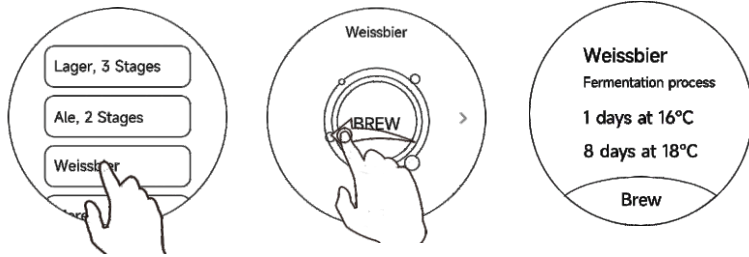

After reviewing and confirming the process, tap on “BREW” to start your brewing journey.

- In the process of brewing, you can observe the current temperature, pressure and remaining time.

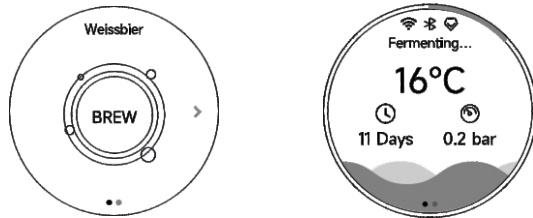

- To view more details, swipe left to access the process details page.

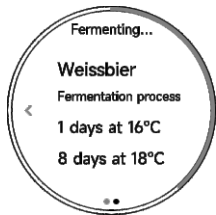

- If you wish to terminate the fermentation, simply tap on “■” at the bottom of the page.

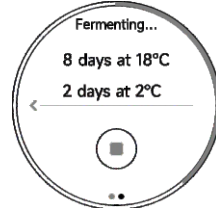

Brewing completed! The screen will automatically jump, and you can enjoy fresh beer brewed by yourself. Tap on ✓ and the device will jump to the “🍺” page, continuously providing cooling and preserving freshness for your beer.

Note: If the user does not perform any operation within a certain period of time, the machine will automatically jump.

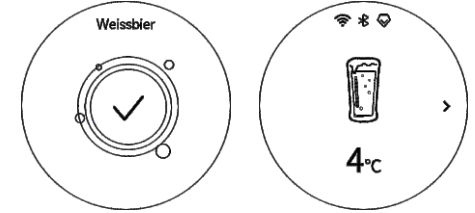

Below the “🍺”, the current temperature of the machine is displayed, while swiping left reveals additional information, including the present gas pressure and the type of gas source being utilized.

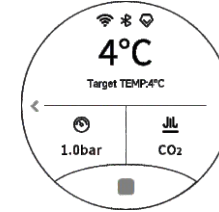

Press “🍺” to switch the gas source from the CO₂ to air.

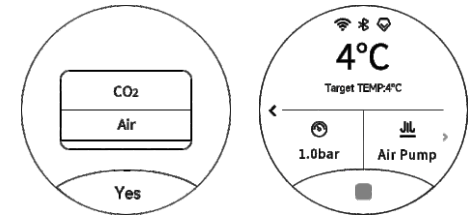

Note: If you desire your beer to remain fresh for an extended period of time, it is recommended to refrain from altering the gas source. Should you opt to switch to air as the gas source, it is advisable to consume the beer as soon as possible.

Tapping on “■” will end the cooling process and return to the list of functions.

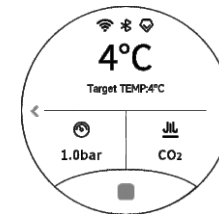

③ Initiating Fermentation Process via App (for Premiums Only)

For details, please refer to the App Operation Guide.

Enjoying Fresh Beer

Upon completion of fermentation, the screen will indicate that the brewing process is finished and the ambient lights will turn green. In the meantime, the brewing completion notification will be pushed to your mobile device via the App. At this point, all that is required of you is to pull the tap handle and indulge in the delight of freshly brewed beer.

Drinking Tips

Tips for Reducing Foam

- Tip 1:** Use cups that have been chilled or maintained at room temperature to receive the beverage.
- Tip 2:** Regulate the flow of the liquid by adjusting the clamp on the tube.
- Tip 3:** Try to allow the beer to enter the cup along the wall.

Storage of Beer

- After fermentation, the beer must be stored under refrigerated conditions.
- If an air pump is used for dispensing the beer, it should be consumed as soon as possible.
- Do not store beer in an environment below 0°C!

Abnormal Conditions

- Do not drink beer if it is found to be moldy, sticky, smelly, or otherwise abnormal.
- Fresh beer contains yeast, turbidity, and sedimentation are normal phenomena and can be consumed normally.

Cleaning and Sanitizing the Keg and its Accessories

For detailed steps, please refer to the section “Cleaning and Sanitizing the Keg and its Accessories” on P28.

6. Cooling & Dispensing Mode

In the Cooling & Dispensing Mode, the adjustable temperature range is 2-12 °C, and there are three modes for you to choose from.

Note: Due to limited screen UI display, the ‘Cooling & Dispensing Mode’ is simplified to ‘Cooling’.

Gas-free Mode

In the Gas-free Mode, the machine only turns on the compressor for cooling, and do not use air pump or CO₂ cylinder for pressuring. You can set the cooling temperature to lower the temperature inside the machine to the target temperature and maintain it. Once the cooling reaches the target temperature, the screen will display the current temperature in real-time.

Compatible Illustration

In this mode, the machine can be used in conjunction with the AT Dispenser Coupler. And this mode is suitable for cooling and dispensing most kegs with built-in pressure systems, such as 5L Heineken Draught kegs, 5L Krömbacher Bilson kegs, etc, which does not require the use of a CO₂ cylinder or the internal gas pump.

Taking the 5L Heineken draught keg as an example, the installation instructions are as follows.

Installation

1. Place the 5L Heineken keg into the machine.
2. ⚠️ Close the Pinch Valve to its full clamping force to prevent accidental splashing.

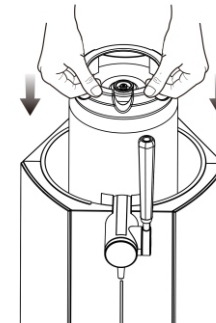

3. Pull the tap handle to its full extent and insert the AT Dispensing Coupler into the faucet until it cannot not be inserted.

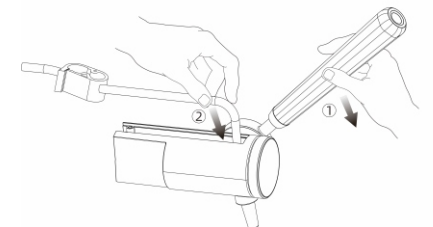

4. Attach the AT Dispensing Coupler onto the Heineken keg. A clicking sound indicates it has been installed properly.

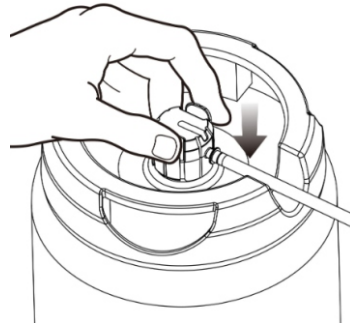

Note: Please install the Dispensing Tube first, and then install the AT Dispensing Coupler into the Heineken keg, otherwise it may cause harm.

5. Swipe down to select the “Gas-free Mode” in the Cooling & Dispensing Mode in the function list, and click to enter the refrigeration process page, where you can set the refrigeration temperature.

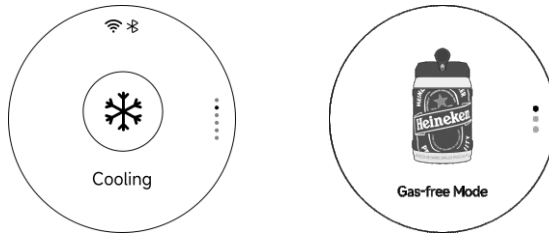

6. Click “Set” to set the cooling temperature, and click “Yes” to confirm it.

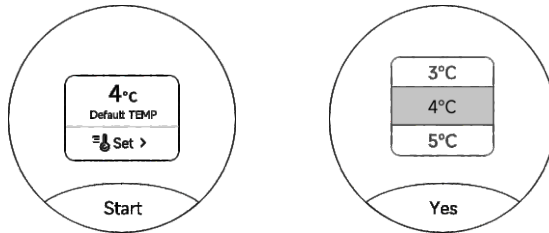

7. Tap on the “Yes” button to start refrigeration. Swiping left, you can access details about the refrigeration procedure.

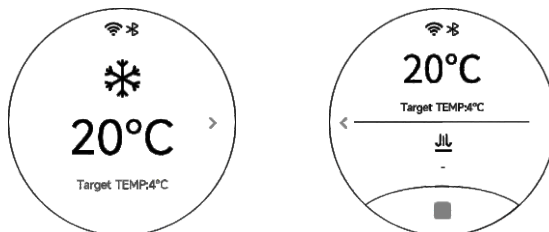

8. Upon reaching the desired temperature, it will automatically transition to the “” page. Now you can enjoy the beer!

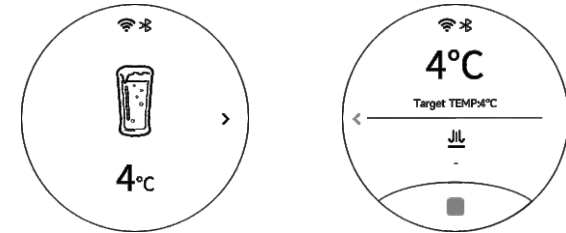

After Use

1. Exit the Cooling & Dispensing Mode.
2. Removing the AT Dispensing Coupler by pinching both sides of its top.

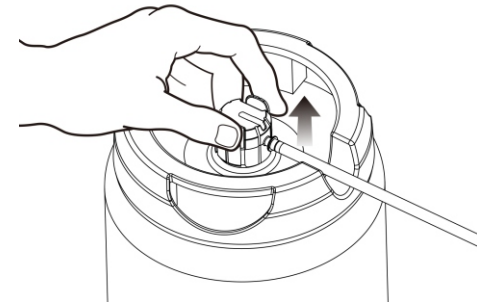

3. Pull the tap handle to its full extent and remove the AT Dispensing Coupler.
4. Take the Heineken keg out of the machine.
5. Clean and sanitize the inner wall of the machine and the spout on the faucet.
6. Clean and sanitize the AT Dispensing Coupler.

Co₂ Mode

In CO₂ Mode, the machine will turn on the compressor for cooling, while using CO₂ cylinder to replenish the pressure in the keg to the most suitable pressure for beer consumption. This mode can preserve beer for a long time and maintain its flavor and taste. You can set the cooling temperature to lower the temperature inside the machine to the target temperature and keep it to the target temperature.

Compatible Illustration

In this mode, the machine can be used in conjunction with the AS Dispensing Coupler. This mode is suitable for cooling and dispensing 5L kegs with specific Pressure Relief Valve (as shown in Figure 1).

such as: Benediktiner Weissbier 5L kegs, Bitburger Premium Pils 5L kegs, Köstritzer Schwarzbier 5L kegs, Feldschlößchen Pilsner 5L kegs, Franziskaner Weissbier 5L kegs.

etc. The characteristics of the Pressure Relief valve are as follows:

1. The middle of the valve is a red plastic part with safety buckles;
2. The surrounding area of the valve is covered with black silicone;
3. The Pressure Relief Valve can be easily removed by pulling.

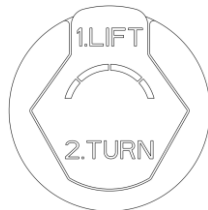

Figure 1

Note: Kegs with other pressure relief valves (as shown in Figure 2) that are difficult to remove can not be adapted to this machine.

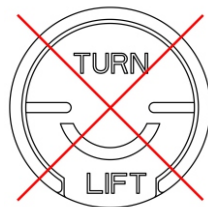

Figure 2

Installation

Step 1: Cooling the Beer

1. Place the keg in the refrigerator, cool it at 4°C and let it stand for at least 12 hours.

⚠ Please make sure to refrigerate and let it stand before drinking, otherwise it may cause the liquor to gush.

Step 2: Installing the AS Dispensing Coupler

2. After standing the cooled keg for 12 hours, open the Pressure Relief Valve to release the pressure of the keg following the instructions on the keg.
3. And then remove the red plastic part in the middle of the Pressure Relief Valve straight up.
4. Insert the AS Dispensing Coupler quickly into the keg.

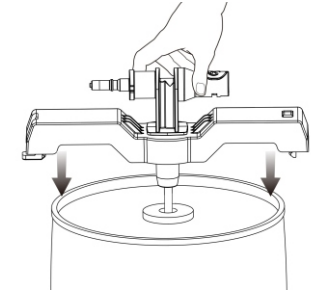

Step 3: Placing the Keg and Starting the Cooling & Dispensing Mode

5. Place the keg in the machine.

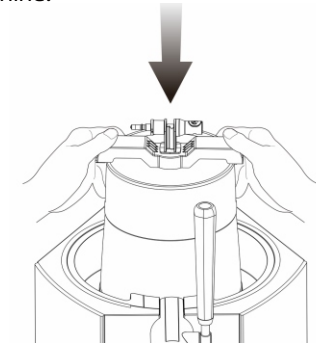

6. Swipe down to select the “CO₂ Mode” in the Cooling & Dispensing Mode in the function list, and click to enter the refrigeration process page, where you can set the refrigeration temperature.

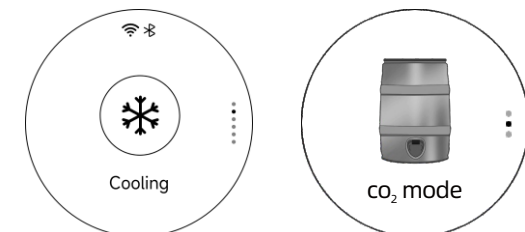

7. Click "Set" to set the cooling temperature to 4°C, and click "Yes" to confirm it.

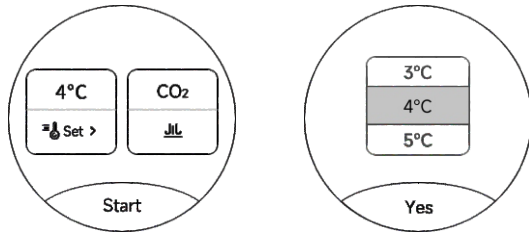

8. Tap on the "Yes" button to start refrigeration. Swiping left you can access details about the refrigeration procedure.

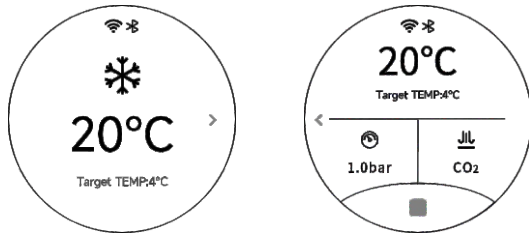

Step 4: Connecting the Dispensing Tube and Drinking

9. Pull the tap handle to its full extent and insert the Dispensing Tube into the faucet until it cannot be inserted.

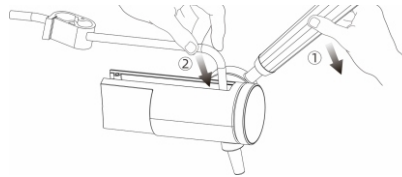

10. Attach the plug of the Dispensing Tube to the Dispensing Outlet of the AS Dispensing Coupler. A clicking sound indicates it has been installed properly.

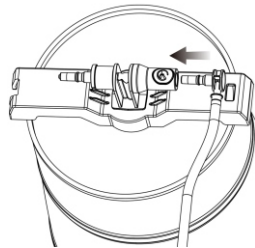

Note: After installing the Dispensing Tube, you can drink the beer until it can not be dispensed. Then please connect the Pressurized Gas Connector to Pressurize and enjoy your beer again!

Step 5: Connecting the Pressurized Gas Connector to Pressurize

11. Attach the Pressurized Gas Connector to the Pressurized Gas Inlet of the AS Dispensing Coupler. A clicking sound indicates it has been installed properly.

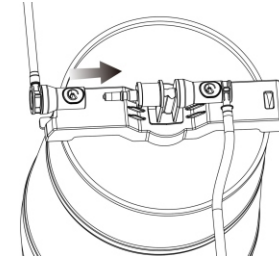

Note: On the refrigeration process page you can switch to air as the gas source by pressing "JIL".

⚠ In the Cooling & Dispensing Mode, CO₂ is used as the gas source by default. If CO₂ is used as the gas source, please refer to the instructions of "Usage of CO₂ Cylinder and Pressure Reducing Valve" mentioned earlier, correctly install the CO₂ gas cylinder and open the Pressure Reducing Valve Switch. Once the air source is switched to an air pump, it can not be switched back to CO₂. So it is advised to consume the beverage as soon as possible!

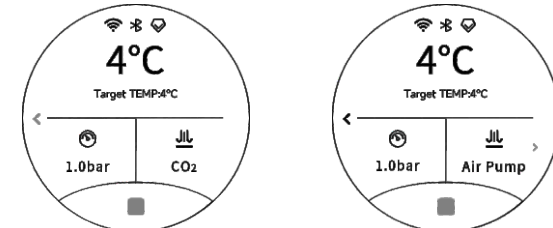

After Use

Reminder: To avoid danger caused by excessive pressure in the keg, please perform the following operations after fully consumed up the beer in the keg.

1. Exit the Cooling & Dispensing Mode.
2. Press and hold the button on the Pressurized Gas Connector, and take it down.

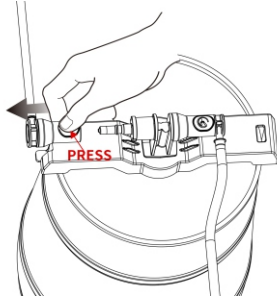

3. ⚠️ Pull the Tap Handle and exhaust the remaining gas from the keg.
4. Press and hold the button on the Dispensing Outlet of the AS Dispensing Coupler to take down the plug of the Dispensing Tube.

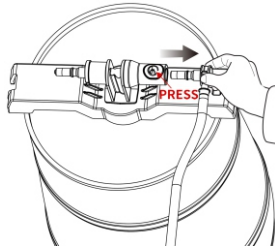

5. Remove the Keg from the machine.

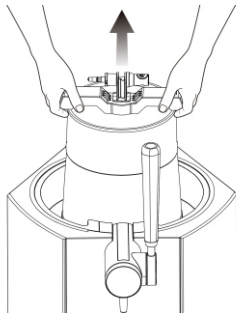

6. Remove the AS Dispensing Coupler;

⚠️ Do not remove the AS Dispensing Coupler while there is still gas in the keg!

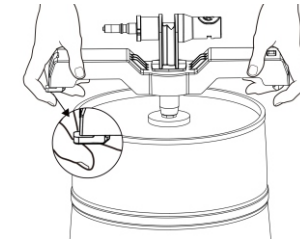

7. Clean and sanitize the inner wall of the machine and the spout on the faucet.
8. Clean and sanitize the AS Dispensing Coupler and the Dispensing Tube.

Air Pump Mode

When you lack the CO₂ cylinder or the CO₂ is depleted, you can also use the Air Pump Mode for cooling and dispensing. You can directly select the Air Pump Mode, or switch the gas source from "CO₂" to "Air" in CO₂ Mode (please refer to "Step16" in the "Installation" on the PX for details).

⚠️ In general, it is not recommended to directly use the Air Pump Mode to dispense, which is not conducive to the flavor of the beer. In addition, after switching the gas source to air, it will not be able to switch back to CO₂, and it must be consumed as soon as possible!

7. Cleaning and Sanitizing

Cleaning and Sanitizing the Keg and its Accessories

After each use, please clean and sanitize the keg and its accessories by the following steps.

1. Tap the button on the Pressurized Gas Connector, while lifting it upwards to detach the Pressurized Gas Connector from the keg.



2. Press the button on the Dispensing Outlet of the keg and simultaneously raise the plug of the Dispensing Tube upwards to remove it.

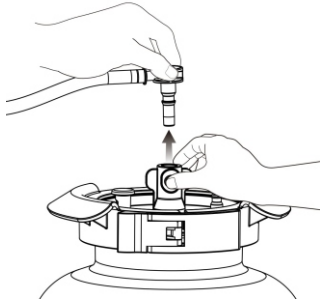

3. Remove the Magnetic Tube Cap, pull the tap handle until it reaches its maximum extent, and then remove the Dispensing Tube.

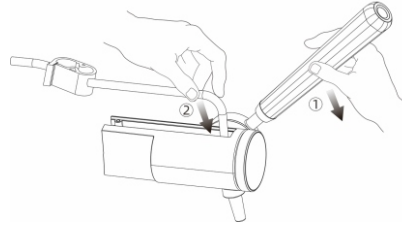

4. Lift the Safety Valve to exhaust the gas in the keg.

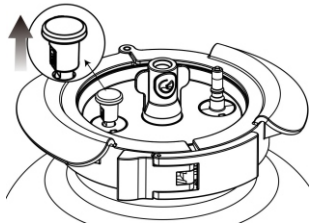

5. Press down on the Keg Lid with both thumbs (only press down, do not open the Clamping Ring).

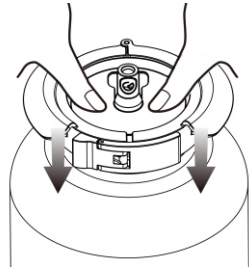

6. Unbuckle the Clamping Ring and separate it from the Keg Lid.

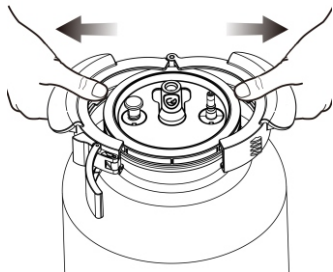

7. Remove the Keg Lid, clean and sanitize the keg and its accessories with detergent.

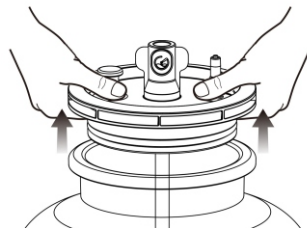

Note:

1. To ensure good airtightness of the keg, there is a Sealing Ring between the keg and its lid, which may result in significant resistance when removing the lid. Be careful of any potential spray of the beer while removing the lid;
2. Unscrewed counterclockwise, the Dispensing Outlet of the keg can be removed for cleaning. To ensure the two ends of the Pressurized Gas Inlet of the keg are connected, please insert the plug of the Dispensing Tube into the Dispensing Outlet of the keg as indicated in the diagram, then clean it as a whole.

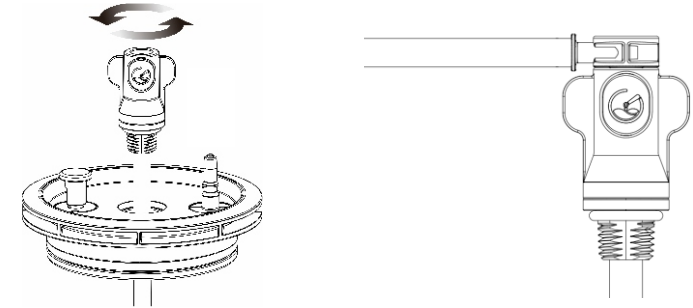

Cleaning and Sanitizing the Machine

1. Open the lid and remove the Pressurized Gas Connector and the Dispensing Tube.
2. Move the keg to a sink or washbasin.
3. Wipe the interior of the machine with soft cloth and clean water.
4. Use another dry soft cloth to absorb the remaining water.
5. After the machine is dry, put the lid back on to prevent anything from falling inside the machine.

Caution:

- Ensure that the power switch is turned off and the power cord is unplugged before cleaning.
- Only use soft (damp) cloth to wipe down the machine. Do not use rough textiles or abrasive agents.

Warning :

- Do not use solvents or harsh chemicals. A mild detergent may be used.
- Do not inject water into the device for cleaning; instead, use a dry cloth to wipe away the remaining water on both the interior and exterior surfaces of the machine after cleaning.
- Do not drain the water remaining inside the machine by flipping it over.

8. Troubleshooting

Troubleshooting Table

Fault Types	Fault Diagnosis	Solutions
The display screen doesn't light up	The plug has come loose	Ensure the plug is inserted properly
	The machine switch is off	Turn on the Power Switch
	The socket is not powered on	Power the socket on
	The socket is faulty	Replace it with a good socket
The tap handle fails to dispense	The Dispensing Tube is not properly connected	Ensure that both ends of the Dispensing Tube are installed in place
	The gas pressure inside the keg is too low	Pump up the keg using the CO ₂ cylinder or air pump
	The keg is empty	Place a new keg inside the machine
	The Keg Tube is not installed	Check and ensure the Keg Tube is installed in place
	The Pinch Valve is closed	Check and ensure the Pinch Valve is open
The Dispensing Tube drips	The Dispensing Tube is not plugged properly	Check if the Dispensing Tube is fully inserted
CO ₂ cylinder fails to pump up the keg	The Pressure Reducing Valve is closed	Open the Pressure Reducing Valve
	The CO ₂ cylinder is out of gas	Replace with a new CO ₂ cylinder
	The CO ₂ cylinder is not installed in place	Tighten the CO ₂ cylinder
	The Pressurized Gas Connector is installed improperly	Check and ensure that the Pressurized Gas Connector is installed in place
Cooling Failure	Cooling & Dispensing Mode has not started	Start Cooling & Dispensing Mode via the control panel or App
	The ambient temperature is too high	Use this machine in a place with good ventilation
	Compressor failure caused by inverted transportation	Bring this machine along with the warranty card to the after-sales service center for repair

Operating Error Popups

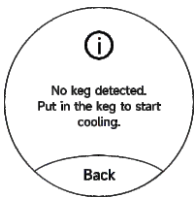

If you encounter the following popups during operation, refer to the table below and taking corresponding measures to improve it. If the issue remains unresolved, please contact iGulu customer service for assistance.

Popup Name	Popup Display	Solution
Check if you need to quit Fermentation Mode		<ul style="list-style-type: none"> If yes, the machine will exit Fermentation Mode If no, the machine will continue to ferment
When the machine loses power unexpectedly during fermentation, it will remind you whether to continue the last fermentation program or not when it is powered on again		<ul style="list-style-type: none"> If yes, the machine will continue to ferment If no, the machine will exit Fermentation Mode
Reminders of high pressure		<ul style="list-style-type: none"> Open the safety valve and discharge a portion of the gas to reduce the pressure inside the keg
Low pressure in Fermentation Mode		<ul style="list-style-type: none"> Check if the Keg Lid and Clamp Ring are installed firmly Check if the Pressurized Gas Connector is properly installed Check if the Dispensing Tube is fastened up Check if the cylinder is filled with CO₂ Check if the Pressure Relief Valve is turned on
Low pressure in Cooling & Dispensing Mode		<ul style="list-style-type: none"> Check if the spear is firmly installed Check if the Pressurized Gas Connector is properly installed Check if the Dispensing Tube is tightly connected Check if the cylinder is filled with CO₂ Check if the Pressure Relief Valve is turned on

<p>No keg is detected in Fermentation Mode</p>		<ul style="list-style-type: none"> • Check if there is a keg inside the machine • Check if the pattern on the keg is complete and replace it with a new one if necessary
<p>No keg is detected in Cooling & Dispensing Mode</p>		<ul style="list-style-type: none"> • Check if there is a keg inside the machine

Machine Error Popups

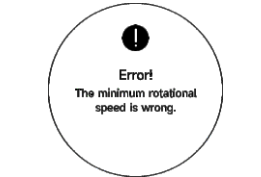
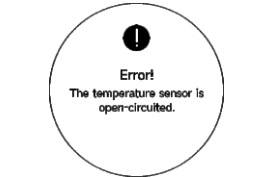
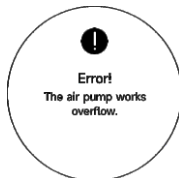
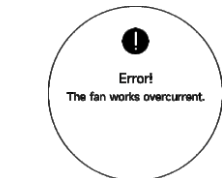
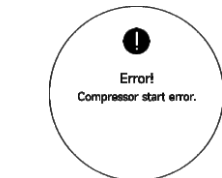
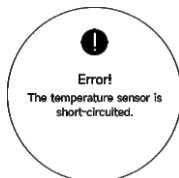
If you encounter the following popups during operation, contact iGulu after-sales directly instead of solving them by yourself.

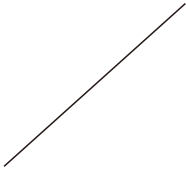
<p>Popup Name & Popup Display</p>	 <p>A short circuit in the temperature sensor</p>	 <p>An open circuit in the temperature sensor</p>
 <p>Overcurrent protection for air pump</p>	 <p>Overcurrent protection for the fan</p>	 <p>A startup error of the compressor</p>
 <p>Minimum RPM error</p>	 <p>Thermal protection for the controller</p>	

Statement

FDA Statement

The materials used in this series of products all comply with FDA requirements in the United States. Some models may not contain individual materials. Please refer to the actual product.

FCC statement

This device complies with Part 15 of the FCC rules. Operation is subject to the following two conditions:

- 1) This device may not cause interference.
- 2) This device must accept any interference, including interference that may cause undesired operation of the device.

Note: This equipment has been tested and found to comply with the limits for a Class B digital device, pursuant to part 15 of the FCC Rules. These limits are designed to provide reasonable protection against harmful interference in a residential installation. This equipment generates uses and can radiate radio frequency energy and, if not installed and used in accordance with the instructions, may cause harmful interference to radio communications. However, there is no guarantee that interference will not occur in particular installations. If this equipment does cause harmful interference to radio or television reception, which can be determined by turning the equipment off and on, the user is encouraged to try to correct the interference by one or more of the following measures:

- Reorient or relocate the receiving antenna.
- Increase the separation between the equipment and receiver.
- Connect the equipment into an outlet on a circuit different from that to which the receiver is connected.
- Consult the dealer or an experienced radio/TV technician for help.

Changes or modifications not expressly approved by the party responsible for compliance could void the user's authority to operate the equipment.

FCC Radiation Exposure Statement

This device complies with FCC RF radiation exposure limits set forth for an uncontrolled environment. This transmitter must not be co-located or operating in conjunction with any other antenna or transmitter.

This device must operate with a minimum distance of 20 cm between the radiator and user body.

Order the Accessories and Recycle

Order Accessories

If you need to purchase accessories or spare parts, please visit www.igulu.com or log in to the official iGulu App for more details.

Recycle

When you dispose of this product, please hand it over to the designated Recycling Center instead of putting it together general household waste for environmental protection.

Please comply with the specialized recycling regulations for electrical and electronic products in your country or region. Proper disposal of waste products can help avoid adverse effects on the environment and human health.

Thank you for choosing iGulu. To get better services, please read this warranty card carefully, fill in the required information, and preserve this card in good condition.

Warranty Card	
User Name	
Address	
Telephone	
Product Name and Model	
Product ID	
Product Date	
This warranty card needs to be properly kept. Buyers do not need to return the card to our company. Please bring this booklet and a valid invoice when repairing.	

Production Place: Zhongshan, Guangdong

Manufacturer: iGulu (Shenzhen) Intelligent Technology Co., Ltd.

Address: Room 612, Building B, Wanyuan Business Building, District 71, Xingdong Community, Xin'an Street, Bao'an District, Shenzhen City

E-mail: ①Business contact: contacts@igulu.com; ②After-sales support: support@igulu.com

For more information, log in to: www.igulu.com

