



Full Motion Single Monitor Desk Mount



Color: Black
Material: Solid Steel

Single monitor mount (model STAND-V001C) made of high-grade steel and aluminum from VIVO. Clear up valuable work space on your desk with this sleek monitor mount. This monitor mount is height adjustable and can swivel and tilt to help place your monitor at the ideal position. This adjustable mount is the perfect fit for anyone who wants to easily adjust their viewing height to an ergonomic level which in return can help reduce neck, back, and eye strain.



Supports screens up to **8kg** Fits most LCD monitors between **13"** and **32"** in size

Height adjustable Ultra heavy duty "C" clamp and optional grommet mounting Integrated cable management system



Made from **Solid Steel**. Heavy-duty design

DESCRIPTION

Thanks for the cup-shaped design, it's easy to tilt, swivel and rotate the monitor.



Dimensions

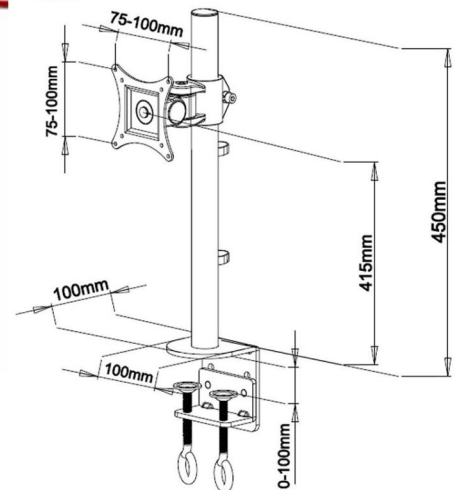

Features

1. **SINGLE MONITOR ARM** – Single monitor mount fits most screens 13" to 30" (13, 15, 17, 19, 20, 22, 23, 24, 27 and 30 inch monitors). Compatible with VESA 75 (75 x 75 mm) and VESA 100 (100 x 100mm).
2. **CLAMP CONNECTION** – C clamp base has integrated double lock that ensures stable mounting onto the desks. Very easy to install.
3. **ERGONOMIC MONITOR RISER** – Improve the ergonomics of your office workstation by raising to monitors to an ergonomic height on your desktop, depending on your sitting position. Avoid neck, shoulder and back pain by improving your posture.
4. **FULL-MOTION STAND** - Monitor holder is height adjustable on the vertical pole, minimum height of 12 inches to max extended 17 inches. Monitor head can tilt up or down 15 degrees, and swivel 360 degrees.
5. **HEAVY-DUTY VESA DESK MOUNT** – Made from solid steel. Heavy-duty design.

Contact us