

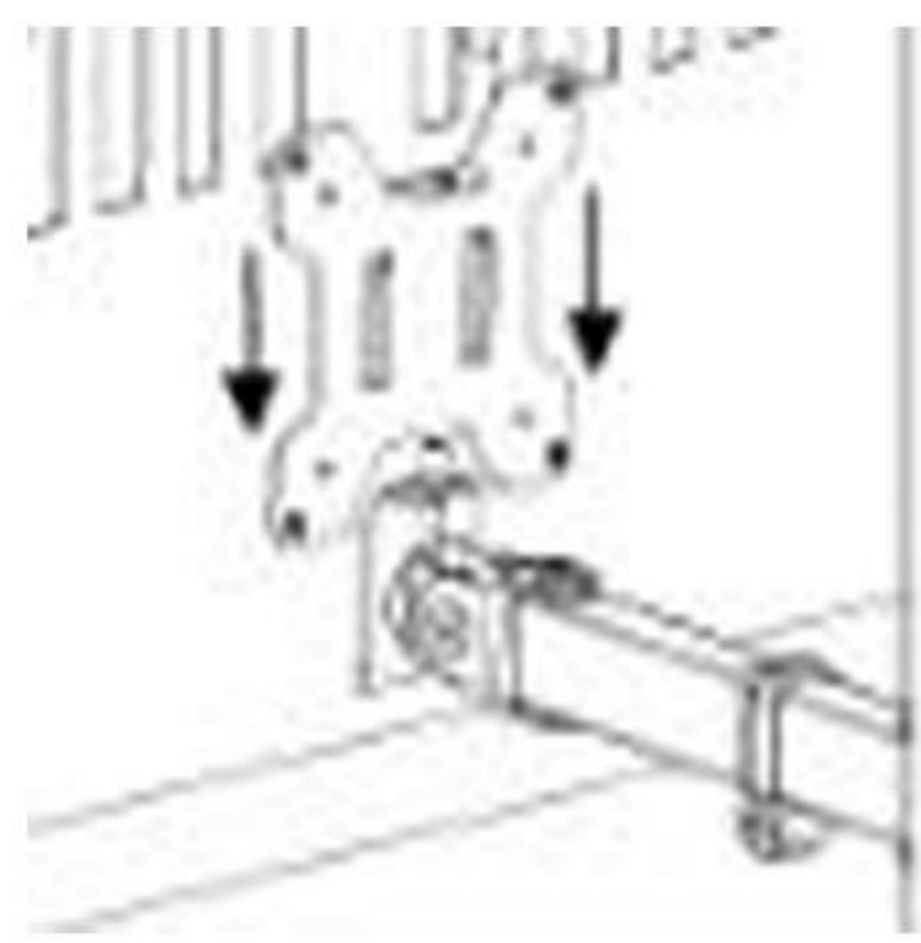

Free Standing Height
Adjustable Two Arm Monitor
Mount



Keep Your Power And AV Cables Clean And
Organized With Detachable Cable Clips On The
Arms And Center Pole



Integrated with removable VESA plate for easy installation.

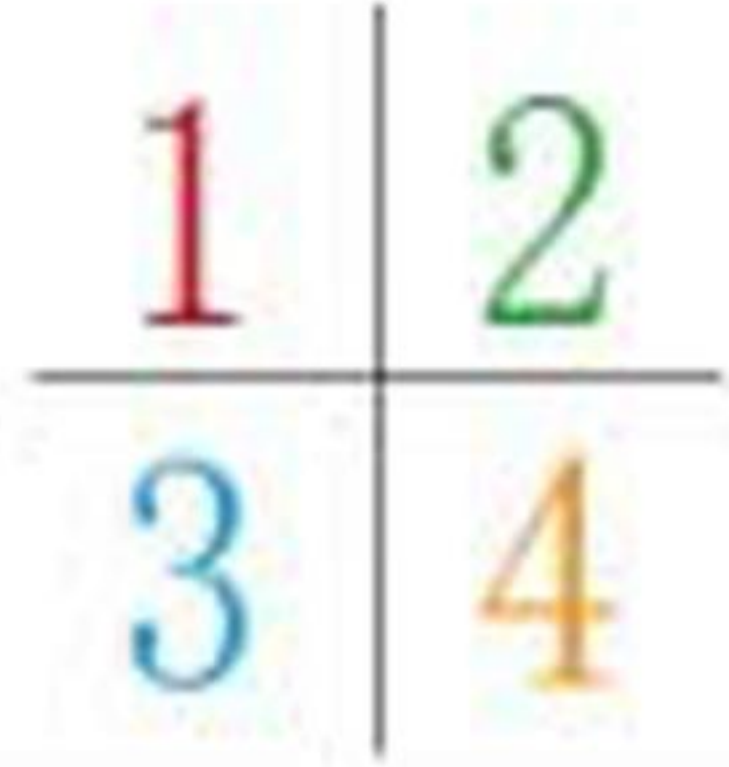

Wide selection for different monitor quantity to meet most applications.



Integrated cable management to organize messy cords.



Place the monitors on the desktop freely with weighted base.



Every Joint Can Be Tightened, So You Can Adjust Exactly How Fluid Or Stationary You Want,

Double center joints built into each arm allow a greater level of arm articulation and monitor placement.



Free-Standing Dual Monitor Mount Made Of High-grade Steel And Aluminum.

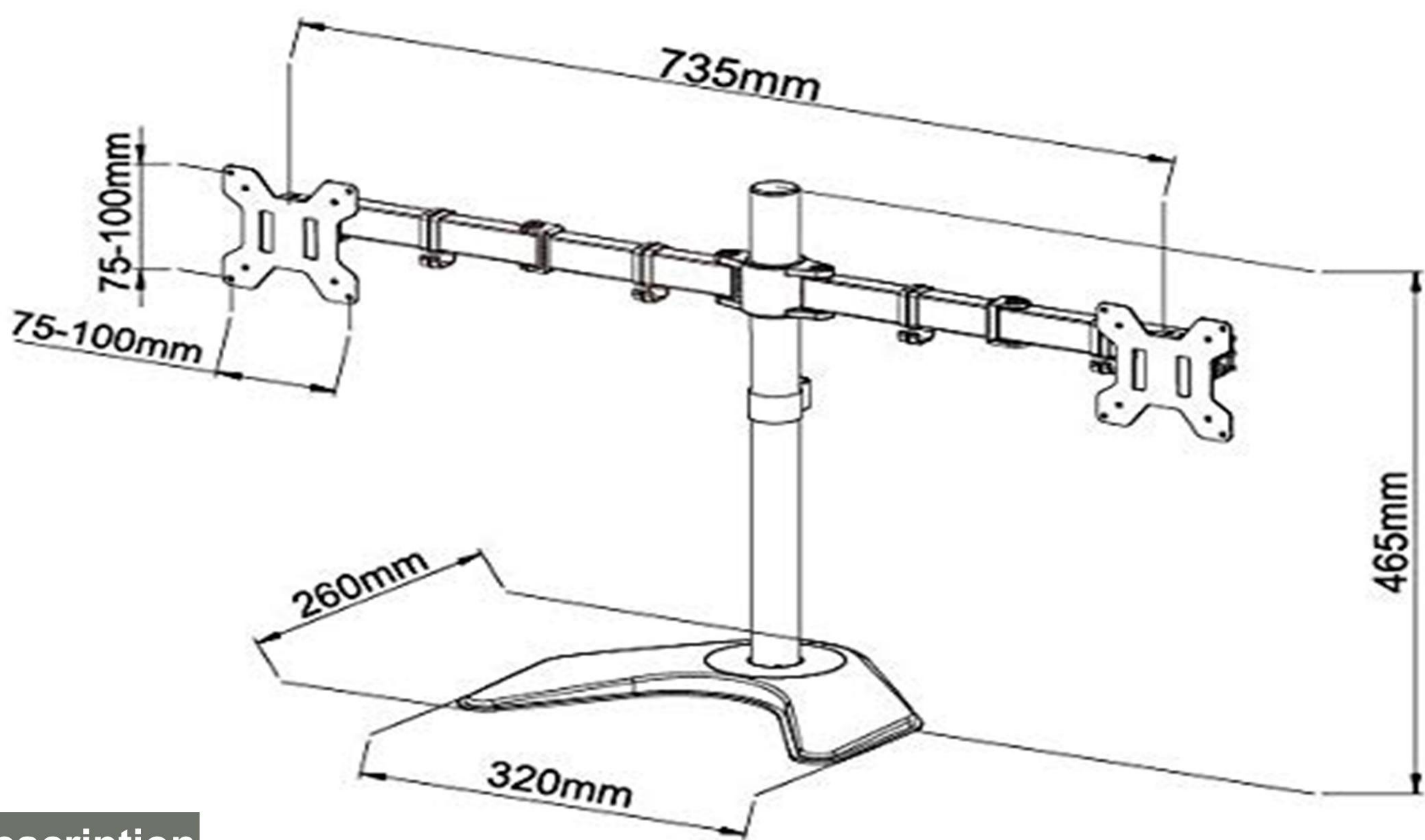

Description

Rife Technologies has earned a reputation for delivering quality yet the elegant mounting solution. For customers seeking a reliable free-standing dual monitor mount, look no further. Rife India offers free-standing dual monitor mount made of high-grade steel and aluminum. Fits most LCD, LCD display up to 27 inches, supports up to 22 lbs. per arm, and compatible with 75x75mm and 100x100mm VESA mounting holes. Every joint can be tightened, so you can adjust exactly how fluid or stationary you want. Special features include the ability for each individual VESA plate to be level adjusted up and down by 0.8" so your monitors will be perfectly aligned. We also made mounting your monitors easy with detachable VESA plates that screw into your monitor and then slide back onto the frame of the stand. Standard monitor mount and display attachment hardware kit with user manual included.

Features

- ➔ **FREE STANDING MONITOR STAND:** This monitor mount firmly hold your monitors without drill a hole on your desk and you can move it as you like.
- ➔ **COMPATIBILITY:** Dual monitor mount fitting two screens 13" to 30" in size and 17.6 lbs in weight with 75x75mm or 100x100mm back side mounting holes (can fit two 32" screens but will allow very limited angled screen positioning). Monitors can be placed in portrait or landscape shape.
- ➔ **FULL ARTICULATION:** Adjustable arm offers -45° to $+45^{\circ}$ tilt, 360° swivel, 360° rotation, and height adjustment along the center pole. Double center joints built into each arm allow a greater level of arm articulation and monitor placement.
- ➔ **HEAVY DUTY BASE:** Measures 11" by 15" providing solid stability while monitors are held within its center of gravity. The bottom of the base features padding to protect your desk from scratches.
- ➔ **INTEGRATED CABLE MANAGEMENT:** Keep your power and AV cables clean and organized with detachable cable clips on the arms and center pole.

CONTACT US



Address 1: Ergonomic Corporation Hongkong Limited, 2nd Floor, Eton Tower, 8th Hysen Avenue Causeway Bay, Hong Kong.

Address 2: Room no. 25, Block B, 5 Floor, Mai Tak Industrial building, 221 Wai Yip Street, Kwun Tong, Kowloon, Hong Kong.

E-mail: sales@ergoshopping.com | **Website:** www.ergoshopping.com | **Tel:** 852-98226451