



Six LCD Monitor Stand or Hex Desk Mount



Six Monitor Stand or display stands or multi monitor mounts and arms, is basically designed to provide a rock solid, free-standing solution desk solution for graphic designers, stock traders, broadcasters and other users who commonly work on multiple monitor or small flat panel TVs, LCDs or monitors. this Premium Four monitor stand has build in ability for independent adjustment of each screen for proper ergonomic viewing posture and alignment and as well smooth, fingertip tilt in all directions.



Holds Six Screens up to 27" in size and 8 kg /monitor in weight with VESA Mount (75 X 75 & 100 X 100 mounting holes)

Build in ability for independent adjustment of each screen for proper ergonomic viewing posture and alignment and as well smooth, fingertip tilt in all directions



Height adjustable With weighted base Integrated cable management system



+15 degree to -15 degree tilt, 360 degree swivel, 360 degree rotation, and height adjustability for optimal viewing angles

Easily adjust each monitor



Fine-tune monitor for proper alignment



CABLE MANAGEMENT

Integrated cable management system
System integrated in order to keep potentially messy cables
clean and org.

DIMENSIONS

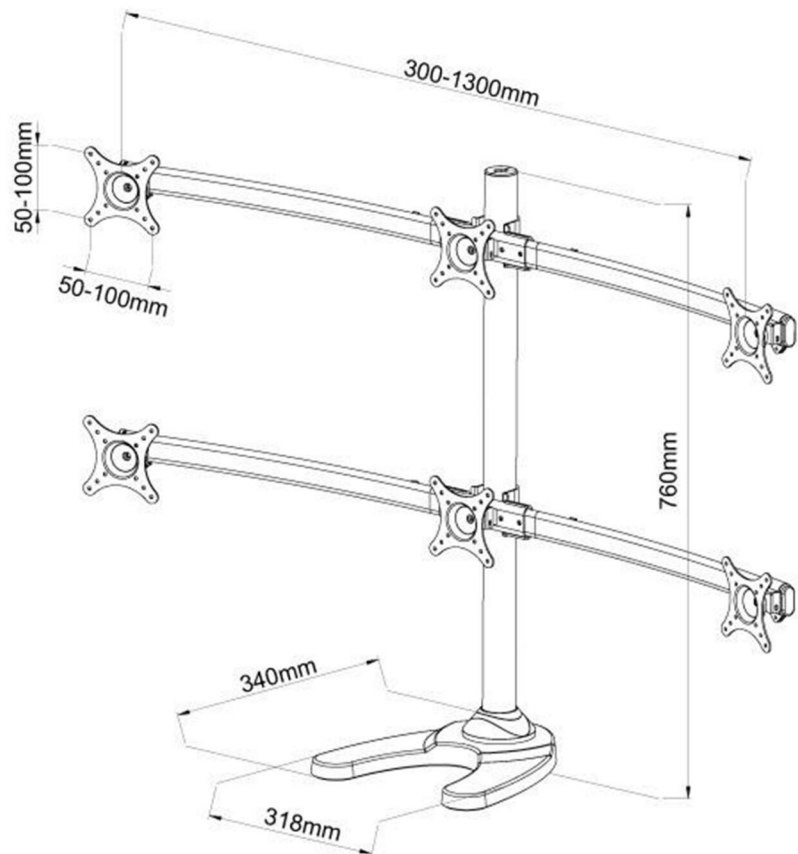



Monitor can be installed either in portrait or landscape shape Easy to line-up monitors by curved arms Monitor height can be adjusted individually.

Features

1. **MOTION:** +15 degree to -15 degree tilt, 360 degree swivel, 360 degree rotation, and height adjustability for optimal viewing angles.
2. **COMPATIBILITY:** Holds Six Screens up to 27" in size and 8 kg /monitor in weight with VESA Mount (75 X 75 & 100 X 100 mounting holes).
3. Independent adjustment of each screen for proper ergonomic viewing posture and alignment and as well smooth, fingertip tilt in all directions.
4. Height adjustable With weighted base Integrated cable management system.
5. **CABLE MANAGEMENT:** System integrated in order to keep potentially messy cables clean and organized.

Contact us



Address 1: Ergonomic Corporation Hongkong Limited, 2nd Floor, Eton Tower, 8th Hysen Avenue Causeway Bay, Hong Kong
Address 2: Room No. 25, Block B, 5th Floor, Mai Tak Industrial Building, 221 Wai Yip Street, Kwun Tong, Kowloon, Hong Kong

E-mail: sales@ergoshopping.com, Website: www.ergoshopping.com, Tel: 852-98226451