

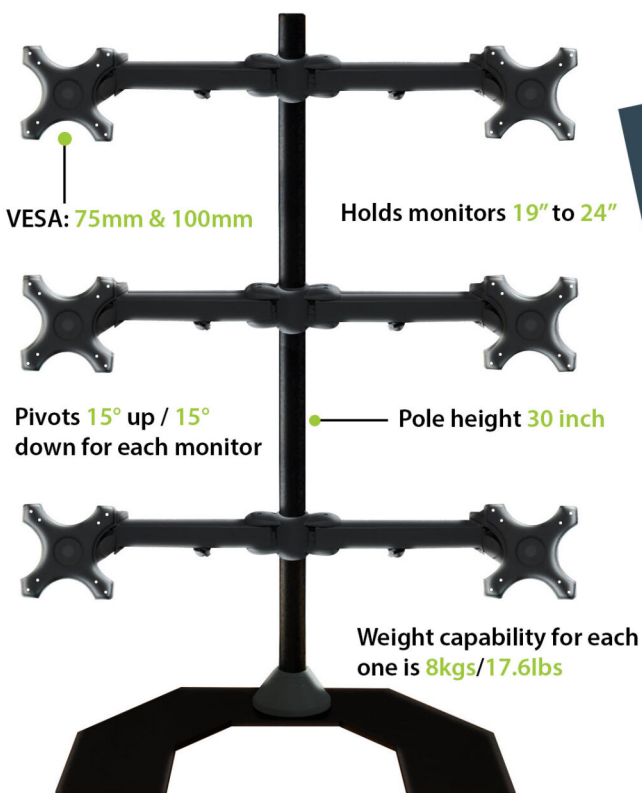

## Six Monitor Vertical Stand

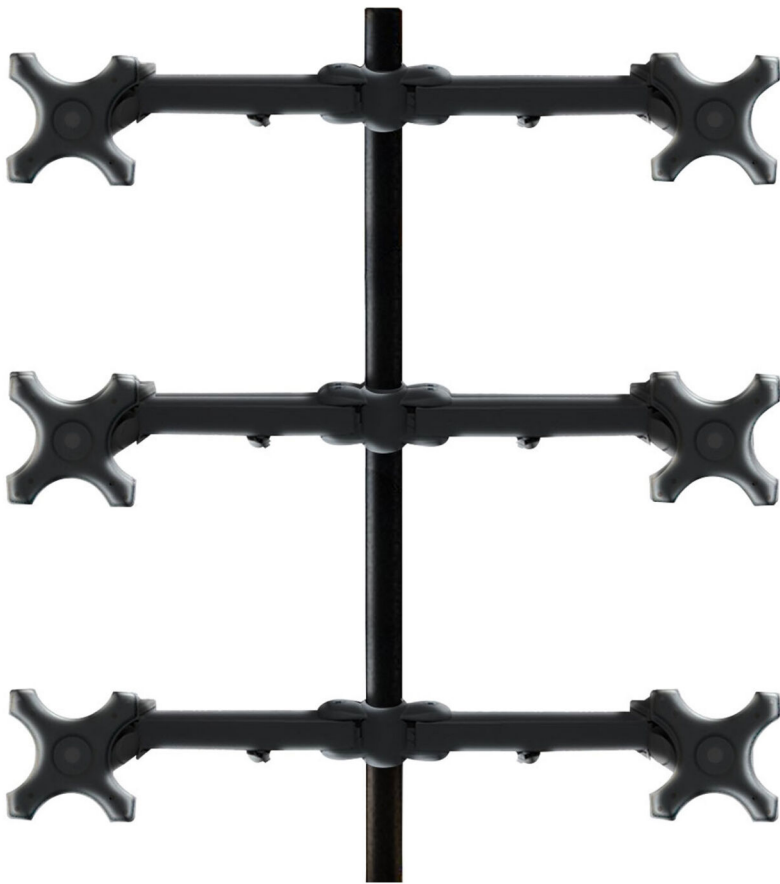

We provide a Multiple monitor stand with 6 monitor or Six display ability. This LCD Monitor stand is an ergonomic Workstation that help to maximize the desk space and reduce the back pain and neck pain. The 6MS-FV is a family of elegant aluminum LCD VESA desk mounts for 19"-24" monitors. It can support two monitors in horizontal line and the weight capability for each one is 8kgs/17.6 lbs. It can rotate for 360°, which allows portrait and landscape viewing.



Elegant aluminum LCD  
VESA 75mm and 100mm  
desk mounts for  
19"-24" monitors

The space between the monitors  
are fully adjustable. Monitors can  
adjust in height, tilt, swivel & rotate

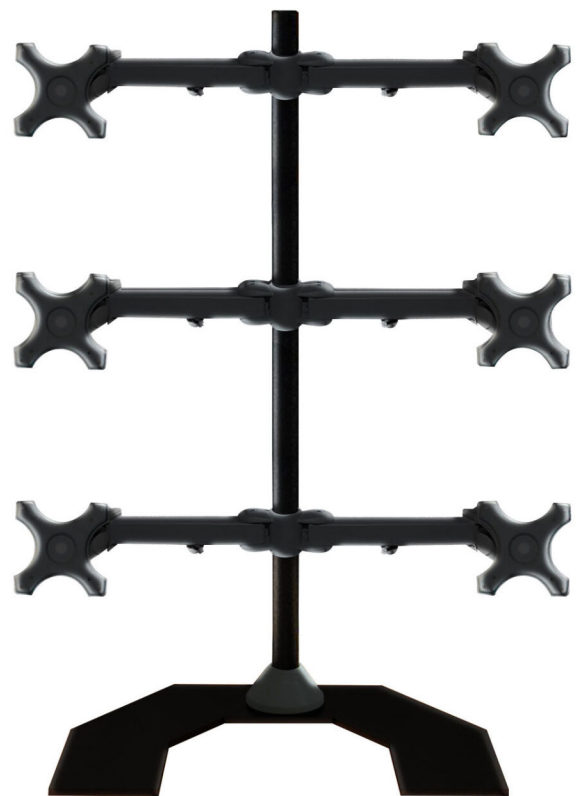

This LCD Monitor stand is an  
ergonomic Workstation that  
help to maximize the desk  
space



# 6MS-FV



## Features

1. Pivots & mounts provides mounting and dismounting.
2. Quick set up and installation.
3. 75mm and 100mm VESA compatible.
4. Pivots 15° up / 15° down for each monitor.
5. Holds monitors 19" to 24".
6. Pole height 30 inch.
7. The space between the monitors are fully adjustable.
8. Monitors can adjust in height, tilt, swivel & rotate.
9. Arms are height adjustable.
10. The height adjustment of arms is continuous along the pole. Just slide the clamp along the pole and adjust using the Allen wrench provided.
11. Each mount can be tilted left, right, up & down. You can also rotate each monitor from portrait to landscape on the fly.

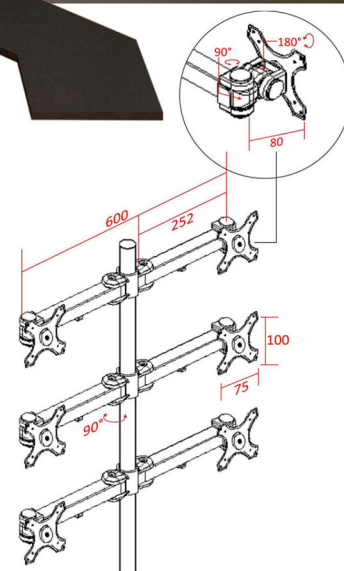

D  
I  
M  
E  
N  
S  
I  
O  
N  
S

## Contact us



Address 1: Ergonomic Corporation Hongkong Limited, 2nd Floor, Eton Tower, 8th Hysen Avenue Causeway Bay, Hong Kong

Address 2: Room No. 25, Block B, 5th Floor, Mai Tak Industrial Building, 221 Wai Yip Street, Kwun Tong, Kowloon, Hong Kong

E-mail: [sales@ergoshopping.com](mailto:sales@ergoshopping.com), Website: [www.ergoshopping.com](http://www.ergoshopping.com), Tel: 852-98226451