

Shelti Eye² User's Manual

MODEL # SD - A - E2

Part Number and Revision Number

P/N 219-0457-2 January 15, 2007

Copyright

Copyright 2007
By Shelti,, 333 Morton Street, Bay City, Michigan 48706

The information in this document is subject to change without notice. No part of this document may be reproduced or transmitted in any form or by any means, electronic or mechanical, for any purpose, without the express written permission of the copyright owner displayed above.

Manual Development

Shelti,,
Product Support Group
469 North California Street
Sycamore, IL 60178

PRECAUTIONS AND SAFETY



TO ENSURE SAFETY WHILE SERVICING, REMOVE POWER CORD FROM WALL OUTLET.



ONLY AUTHORIZED PERSONNEL MAY USE KEYS TO ACCESS THE SERVICE AREAS.



LOCATE GAME CLOSE TO POWER OUTLET. IN CASE OF FIRE HAZARD, UNPLUG POWER CORD FROM OUTLET.



MAKE SURE POWER CORD AND CABLES ARE NOT TRAPPED BETWEEN TOP AND BOTTOM CABINET WHEN GAME IS IN ITS UPRIGHT POSITION.



DO NOT BLOCK VENT HOLES.

ALTERATION TO ANY PART OF THE GAME IS PROHIBITED.

DUPLICATION OF THIS DOCUMENT IS NOT PERMITTED WITHOUT AUTHORIZATION.

LIMITED WARRANTY

Shelti. extends the following warranty to the original purchaser for a period of 1 (one) year from the date of purchase, for units employed in ordinary commercial applications.

Warranty Statement

Shelti . will, at its discretion, repair or replace any part(s), excluding installation & labor, which fail or malfunction due to defects in materials or workmanship during the warranty period. Any replacement parts provided are warranted for the remainder of the original warranty period. Such warranty part(s), repairs, or replacements are subject to the following conditions:

- Owner must ship (or otherwise deliver) the defective part(s) to Shelti and enclose a brief description of the nature of the problem, the address to which the replacement part(s) should be shipped, the model name & serial number, and verification of purchase date & ownership (copy of sales invoice). NOTE: Completing and returning the attached Registration Card at time of purchase eliminates the requirement of a sales invoice if a warranty claim is later made.
- Owner is responsible for shipping charges to and from the manufacturer's facility: Shelti ., 333 Morton Street, Bay City, MI 48706.
- Shelti . reserves the right to substitute parts of equal or greater value and comparable function, in the event such parts have been modified or enhanced since the original owner's game purchase.

Warranty Limitations

This Limited Warranty does not cover the following:

- Any failure caused by or resulting from abuse, neglect or accident; improper use, modification, service, maintenance or repair; or normal wear & tear.
- Cabinet exterior and decorative finishes, including scratches, scrapes, and nicks in laminated surfaces.
- Installation or labor costs, in any form, incurred in any manner. Only part repairs or replacements are provided.
- Damages incurred in shipping, unpacking, set-up, and installation.

NO PERSON, AGENT, DISTRIBUTOR, DEALER, SERVICE FACILITY, OR COMPANY IS AUTHORIZED TO CHANGE, MODIFY, OR AMEND THE TERMS OF THIS LIMITED WARRANTY IN ANY MANNER OR FASHION. SHELTI MAKES NO EXPRESS WARRANTY REGARDING THIS PRODUCT, EXCEPT AND TO THE EXTENT PROVIDED FOR IN THIS LIMITED WARRANTY. ALL IMPLIED WARRANTIES RELATING TO ANY PORTION OF THIS PRODUCT, INCLUDING ANY WARRANTY OF MERCHANTABILITY OR FITNESS FOR A PARTICULAR PURPOSE, ARE LIMITED TO THE DURATION OF THIS LIMITED WARRANTY. SHELTI WILL NOT BE LIABLE TO THE PURCHASER OR ANY OTHER PERSON OR ENTITY FOR ANY INCIDENTAL OR CONSEQUENTIAL DAMAGES OR LOSS OF PROFIT OR PRODUCT RESULTING FROM ANY DEFECT OR MALFUNCTION OR FAILURE OF THIS PRODUCT. SOME STATES DO NOT ALLOW LIMITATIONS ON HOW LONG AN IMPLIED WARRANTY LASTS, OR THE EXCLUSION OF INCIDENTAL OR

LIMITED WARRANTY

CONSEQUENTIAL DAMAGES, SO THE ABOVE LIMITATION AND EXCLUSION MAY NOT APPLY TO YOU. THIS WARRANTY GIVES YOU SPECIFIC LEGAL RIGHTS AND YOU MAY ALSO HAVE OTHER RIGHTS, WHICH VARY FROM STATE TO STATE.

Warranty service is available through your distributor.



SERVICE PHONE NUMBER: 1-989-893-1739

SERVICE FAX NUMBER: 1-989-893-1809



Please fill in the appropriate information for easy reference.

SERIAL NUMBER

(Found on the lower right side of the upper cabinet near the hinge.)

NOTICE

This equipment has been tested and found to comply with the limits for a Class A digital device, pursuant to Part 15 of the FCC Rules. These limits are designed to provide reasonable protection against harmful interference when the equipment is operated in a commercial environment.

This equipment generates, uses and can radiate radio frequency energy and, if not installed and used in accordance with the instruction manual, may cause harmful interference to radio communications. Operation of this equipment in a residential area is likely to cause harmful interference in which case the user will be required to correct the interference at his own expense.

Changes or modifications not expressly approved in written form by SHELTI, INC. for compliance could void the user's authority to operate the equipment.

This digital apparatus does not exceed the Class A limits for radio noise emissions from digital apparatus set out in the radio interference regulations of the Canadian Department of Communications.

Le présent appareil numérique n'émet pas de bruits radioélectriques dépassant les limites applicables aux appareils numériques de la Classe A prescrites dans le règlement sur le brouillage radioélectrique édicté par le ministère des Communications du Canada.

To ensure safety, modification to any part of this game is prohibited.

The keys to this game should not be left in the locks or be accessible in any way to unauthorized service personnel.

This MANUAL is subject to change. Supplement will be available upon request.



Figure 1 - Game in shipped position.

GAME SPECIFICATIONS AND INSTALLATION

SPECIFICATIONS

THIS GAME IS SUITABLE FOR INDOOR USE ONLY.

Height: 86" upright
Weight: 180 lbs.

Width: 24"
Voltage: 100-240V, 50/60Hz

NOTE: A working area of approximately 6 ft. x 4 ft. with a 7.5 ft (90 inch) ceiling clearance is needed to install this game.

INSTALLATION

- 1) Set-up overhead.
- 2) Remove the thumb bolts "C" from the cashbox and set them aside within easy reach.
- 3) Slowly and carefully swing the upper section of the game upright, bracing the back until the game is securely fastened (step 4).
- 4) Verify that the wires are not pinched. Place the bolts "C" in the inside top of the back compartment of the Cougar Eye² and thread upward through holes "B" to secure the upper section of the game. Tighten the bolts.
- 5) This game is equipped with an easily replaceable power/line cord which is located inside the pedestal when shipped. Review top figure on page 12 before proceeding.
- 6) Move the game to its operation location without tilting it more than 10 degrees. Plug power cord into an appropriate outlet.

CAUTION

To ensure safety, it is recommended that the game be secured to the floor or to the wall using the Stability Assurance Kit provided. See instructions on the following pages.



Figure 2 - Valley Cougar Eye² Full Front view.

STABILITY ASSURANCE KIT

(Shipped in Cash Box)

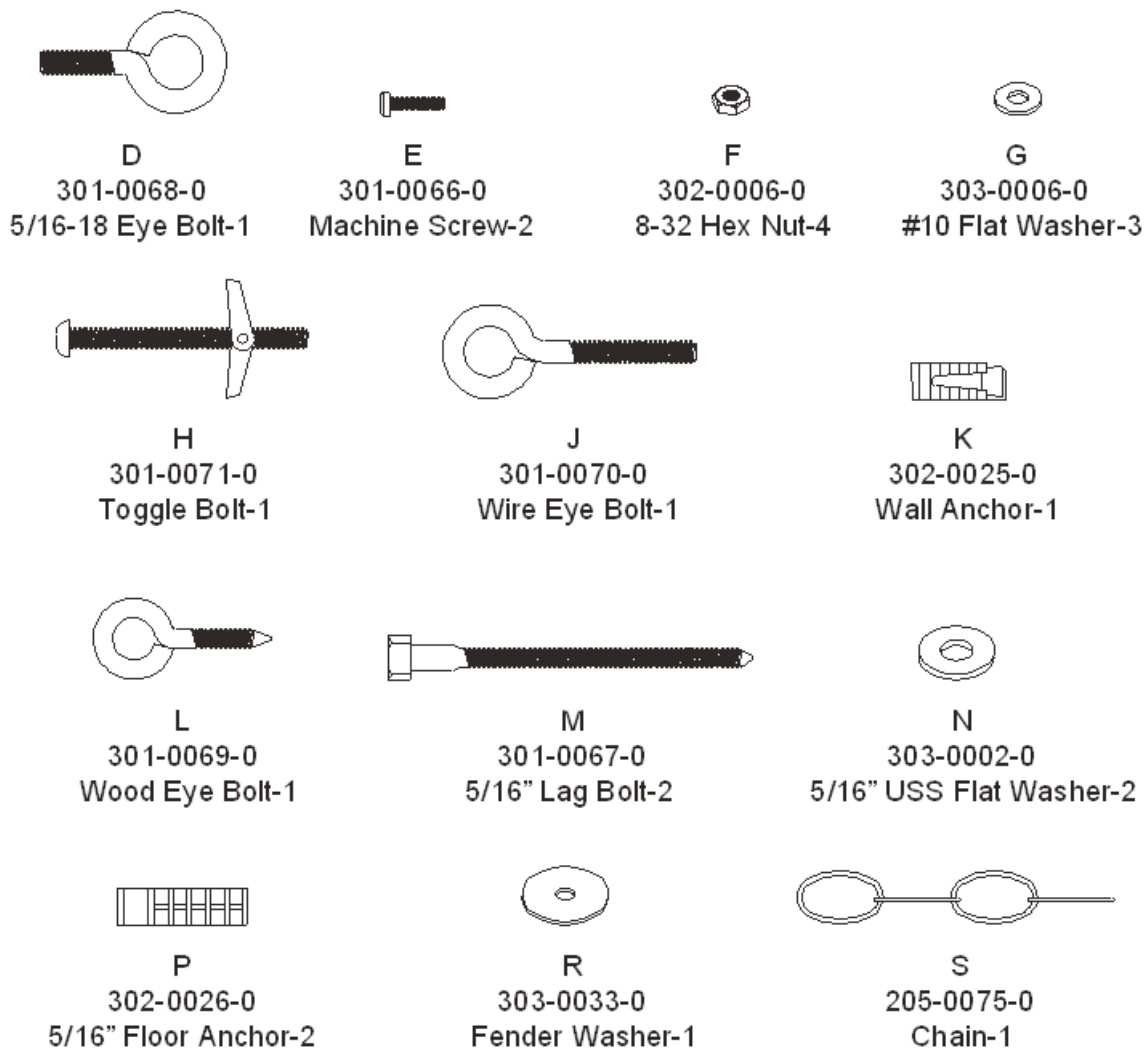

Figure 3 - Stability Assurance Kit

Tools Required:

- Measuring Tape
- Phillips & Flat Screwdriver
- Pliers or Crescent Wrench
- Drill
- 12.5mm (1/2") Drill Bit – for hollow wall.
- 12.5mm (1/2") Masonry Drill Bit – for concrete, brick, or stone wall.
- Hammer

Attachment of the Chain to the Wall.

Step 1: Screw the eye bolt (D) to the dart game. Loop the chain through the eye bolt. Use a machine screw (E), two hex nuts (F), and a #10 flat washer (G) to fasten the chain to itself. See Figure 4.

Step 2: Fasten to the wall according to the appropriate wall “type” instructions A, B, or C.

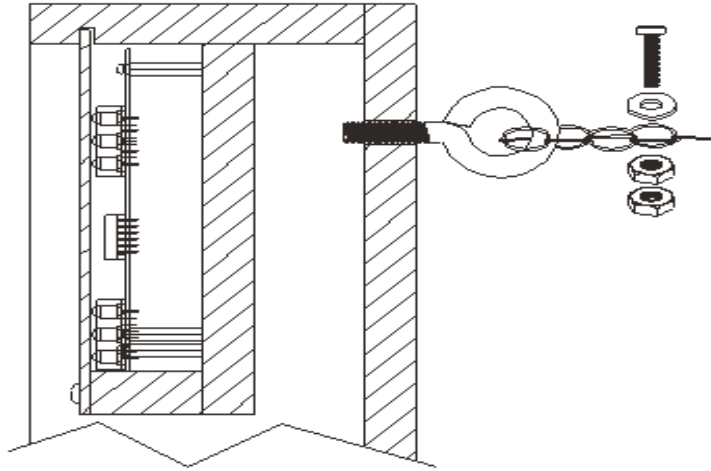

Figure 4 - Eye bolt and chain fastened to game.

A. Hollow Wall: Plaster, Drywall, etc.

1. With the game in position where it will be played, mark a spot on the wall directly in line with the eyebolt and chain attachment on the back of the game.
2. Drill a 12.5mm (1/2”) diameter hole at the marked location.
3. Unscrew the wings from the toggle bolt (H). Place a 5/16” USS flat washer (N) on the toggle bolt.
4. Insert the toggle bolt (H) through a loop in the chain a few inches from the end. See Figure 5.
5. Slide a fender washer (R) on the toggle bolt (H) and screw the wings back on.
6. Push the toggle bolt (H) into the drilled hole in the wall.
7. Fasten the toggle bolt (H) tightly until the wings are snug against the back of the wall as shown. Keep the chain as taut as possible to minimize slack. See Figure 6.

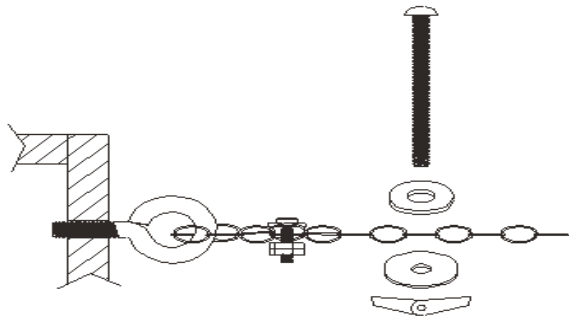

Figure 5 – Toggle bolt close-up

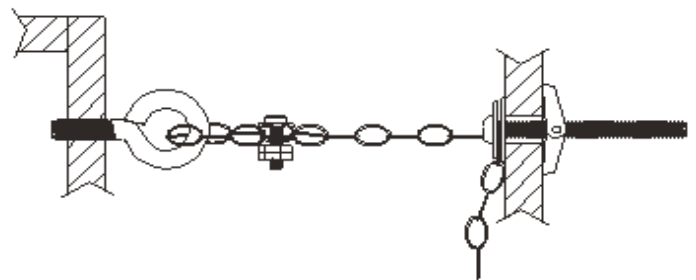

Figure 6 - Close-up toggle bolt installed

B. Concrete, Brick, or Stone Wall.

1. With the game in position where it will be played, mark a spot on the wall directly in line with the eyebolt and chain attachment on the back of the game.
2. Drill a 12.5mm (1/2") diameter hole 35mm (1-1/4") deep at the marked location.
3. Pound the wall anchor (K) into the wall with a hammer until flush with the wall surface.
4. Screw the eyebolt (J) into the wall anchor (K) until it is tight.
5. Thread the chain through the eyebolt and attach it to itself with a machine screw (E), a #10 flat washer (G), and two hex nuts (F) as shown. Keep the chain as taut as possible to minimize slack. See Figure 6.

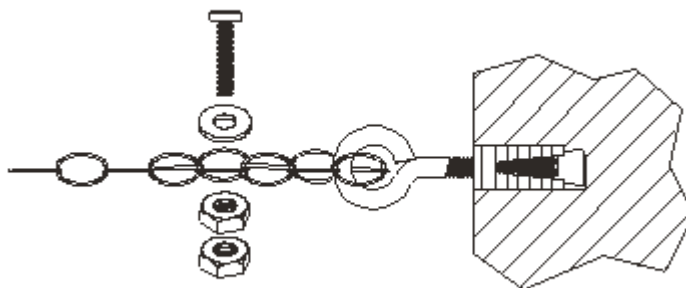

Figure 7 - Fasten to concrete, brick, or stone wall.

. Wood Stud Mounting.

1. With the game in position where it will be played, mark a spot on the wall directly in line with the eyebolt and chain attachment on the back of the game.
2. Screw the eyebolt into the stud at the marked spot.
3. Thread the chain through the eyebolt and attach it to itself with a machine screw (E), a #10 flat washer (G) and two hex nuts (F) as shown. Keep the chain as taut as possible to minimize slack. See Figure 7.

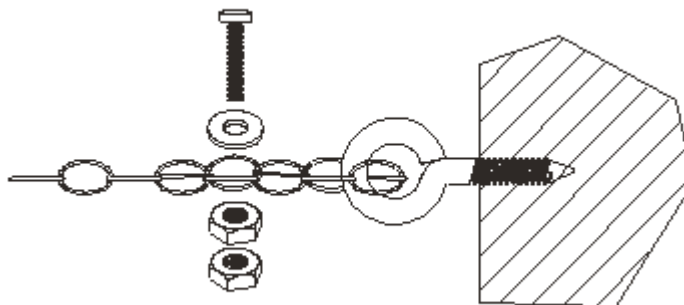

Figure 8 - Fasten to wood stud.

Attachment to the Floor.

Fasten to the floor according to the appropriate floor “type” instructions A or B.

A. Concrete Floor.

1. Mark two spots on the floor according to the diagram. See Figure 8.
2. Drill two hole at the marked locations, each 12.5mm (1/2”) diameter x 45mm (1-3/4”) deep.
3. Pound in the floor anchors (P) with a hammer until flush with floor.
4. Align the holes in the base of the game with the floor anchors (P). The holes in the base of the game can be located through the hole in the back of the game.
5. Secure the game with the flat washers (N) and lag bolts (M). See Figure 9.
6. Tighten the lag bolts (M) until flush with the base.

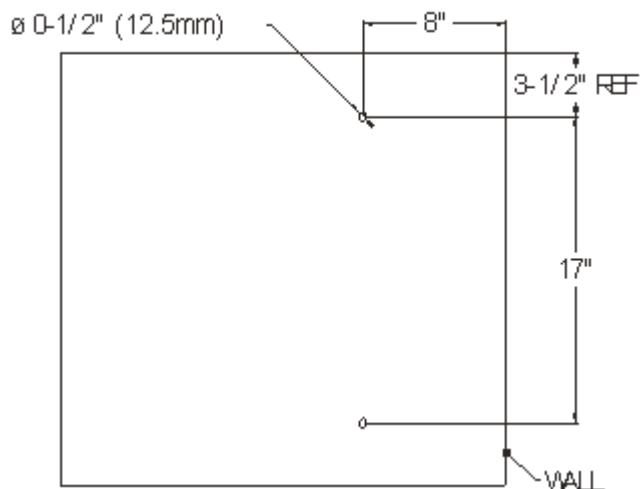

Figure 9 - Floor layout.

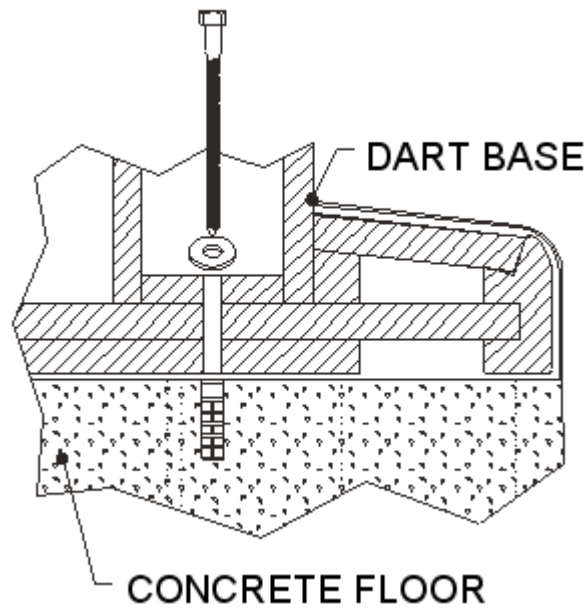

Figure 10 - Fasten to concrete floor.

B. Wood Floor.

1. Position the dart game in its desired location.
2. Secure the game with the washers (N) and lag bolts (M). NOTE: If desired, a 6mm (1/8") diameter pilot hole may be used to start the lag bolt. See Figure 10.
3. Tighten the lag bolts (M) until flush with the base.

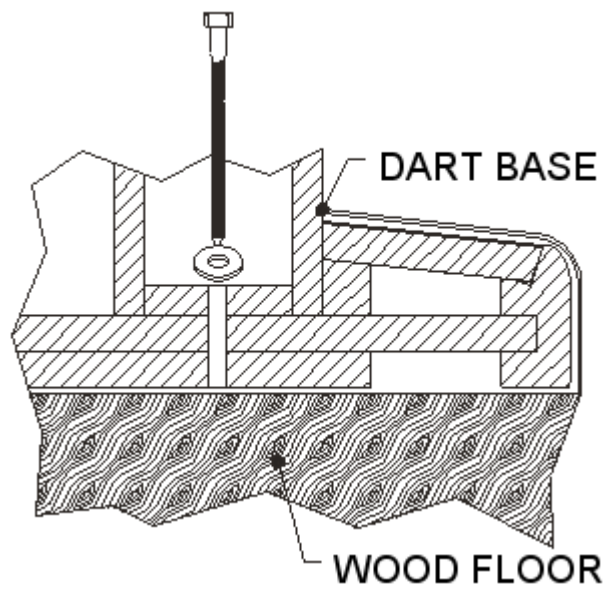

Figure 11 - Fasten to wood floor.

GAME SPECIFICATIONS AND INSTALLATION

GAMES

301, 501, 701, 901

Options for 301/501/701/901

- Wipe Out™
- Double In
- Double Out
- Masters Out
- Double In/Double Out
- Double In/Masters Out
- Team Play
- NDA Handicapping (301,501 only)
- ADA Handicapping (301 only)

Cricket

Options for Cricket

- Cut Throat
- You Pick It
- Chance It
- Mark 21
- Team Play
- NDA or ADA Handicapping

Hi Score

Shanghai

Rapid Fire™

GAME SELECT PANEL



Figure 12 - Game Select Panel

MISSED DART DETECTOR

TRU-SCORE® AND TRU-SCORE® II

The Eye² game is equipped with two specialized hardware and software systems. Tru-Score® accurately scores those darts which hit within a target segment. Tru-Score®II properly registers any hit outside the target with the help of an impact sensor to detect darts which bounce off the door or hit the dart catching ring. Missed darts are indicated by a short tone. Because the Eye² registers every dart thrown, the game signals when to remove darts.

This feature is factory adjusted and ready to use. If further adjustments are necessary, refer to the Missed Dart Sensor Adjustment Procedure located in this manual.

Figure 13 - Missed dart sensing areas.

GENERAL PLAYING INSTRUCTIONS

1. Insert coins. The number of credits entered will be shown in ROUND display. Use the arrows on the top of the keypad to navigate to the game you want to play. Select the game type and game followed by the game option.
2. Select “Casual Play” or “Team Play”, and then select the number of players or positions.
3. Press “Game Start” key. At this time, the balance for remaining credits will appear on the upper display. Deposit the requested number of credits.

TO START THE GAME

- Wait for “Player 1” prompt to be displayed.
- Throw the first dart, **OR**
- Select a different game by pressing the “Clear” button on the keypad.
- After 3 darts have been thrown, “Retrieve Darts” will be displayed, and then the player can remove the darts. Note that the Player Change button will always command the game to change players.

NOTE: If all 3 darts have not been registered, the player **must** activate the PLAYER CHANGE button **before** removing darts.

TO BACK UP THROWN DARTS

If it is necessary to ‘back up’ and erase thrown darts from the games memory during play of the game, the players may do so one dart at a time, provided the Back Up feature is enabled. At any time during the game, to back up one dart, use the keypad to spell out B-A-C-K (2225) and press ENTER. A maximum of 12 darts may be backed up in any one game. A warning beep will sound if an attempt is made to go past the limit or if an attempt is made to back up past the first dart of the game. Multiple darts can be backed up at one time. (Example: Darter throws out-of-turn – all darts thrown can be backed up.)

Keypad display will show “Dart Roll Back.” To subtract throws, use the left arrow. To add throws back, use the right arrow. The keypad display will show the number of backed throws. When this number is correct, press the “Enter” key. The upper display will refresh to the backed-up position.

PLAYING INSTRUCTIONS FOR EACH GAME

301

- Beginning with a score of 301, player(s) must score down to exactly 0. The first player to reach 0 wins.
- Any points scored exceeding the point total needed to reach 0 will result in a BUST. The player forfeits any remaining darts in that round. Player's score will return to the score at the beginning of the round.

501/701/901

- Same game as 301 except that the starting score is 501, 701 or 901 points.

OPTIONS FOR 301/501/701/901

Open In/Out

- The first throw begins the game and the game may be ended by any single, double, or triple value segment.

Double In

- Each player must hit a double point value segment or an inner Bull's Eye to begin play.
Darts thrown prior to the first scoring throw will not score points.

Double Out

- A player must reach 0 exactly by scoring a double point value segment or an inner Bull's Eye. A score of 1 will automatically bust a player in this position.

Double In/Double Out

- This is a combination of the Double In and the Double Out games.

Masters Out

- This is played the same way as Double Out, but the player can also go out by hitting a triple point value segment or a Bull's Eye.

Double In/Masters Out

- This is a combination of the Double In and the Masters Out games.

Wipe Out™

- Played the same way as other '01 games except that each player has the opportunity to send other players' scores back to the starting score or adds 103 points not to exceed starting score. The latter is **WIPE OUT™** 103 (Refer to Game Config Programming for this setting).
- Each player begins with 301, 501, 701, or 901.
- The first player to reach 0 exactly within the round limit or the player with the lowest score after the round limit is the winner.
- Each player can wipe out other players by matching their scores with any or all of the three darts thrown. [Example: Player 1 has a score of 80 points, Player 2 has a score of 40 points, Player 3 has a score of 70 points, Player 4 has a score of 10 points. Player 1 shoots a 10 with his first dart for a score of 70. This matches Player 3's score so Player 3's score returns to 301. Player 1 shoots again and hits a Double 15 for a

PLAYING INSTRUCTIONS

score of 40. This matches Player 2's score, and sends her to 301. Player 1 shoots a third dart and hits another Double 15, bringing the score to 10 which matches Player 4's score. Player 4's score returns to 301. If **WIPE OUT™** 103 is set in the previous example, the players' scores will be as follows: Player 2 = 143, Player 3 = 173, and Player 4 = 113.]

TEAM OPTIONS FOR 301/501/701/901

- A player is "frozen" when the score of the other player on the team is greater than or equal to the combined score of the opposing team's players. A player cannot win the game if his partner's score is greater than the opposing team's **combined** score; this situation causes that player to be "frozen," i.e., if the partner's score is 50 and the opposing team players have 15 and 10 totaling 25 points.
- If a player is "frozen" and reaches 0, the game will cause this player to bust when programmable feature ('01 Freeze) is set to 'BUST'. When programmable feature is set to 'LOSE', the game will cause the team to lose.
- NDA Handicap play available.

Team: 4 Player; 2 Position

- This option is only valid for 2 teams and can be chosen when there are enough credits for a 2 player game.
- Players 1 and 3 are Team "1" and their score appears on Player 1. Players 2 and 4 are Team "2" and their score appears on Player 2.
- After selecting an '01 game and option, press Team Play and then select 2 Pos.
- The display will automatically put up a 4 player, 2 position team game.

Team: 4 Player; 4 Position

- This option can only be chosen when there are enough credits to start a 4 player game.
- Players 1 and 3 are Team "1." Players 2 and 4 are Team "2."
- After selecting a '01 game, press Team Play and then select 4 Pos.
- The game will automatically put up a 4 player, 4 position team game.

WIPE OUT™ TEAM RULES

- Regular Team rules apply.
- Players cannot wipe out a team member if they match their team member's score.
- Players on one team may eliminate players on the other team by matching their score as described previously.
- The team with the first player to reach 0 before the round limit is the winner as long as cumulative score of winning team is less than the cumulative score of the other team. A team player reaching 0 without having the lowest cumulative team score could:
 1. cause the player to "Bust," and his score will return to that of the previous round

OR

 2. lose the game depending on how Programmable Feature '01 Freeze is set.
- If the round limit is reached, the team with the lowest cumulative score is the winner.

PLAYING INSTRUCTIONS

Traditional Cricket

Objective

In traditional Cricket, the object is to close numbered segments by hitting each one the equivalent of three times. [Example: To close segment #20, a player must throw 3 darts in the single, 1 dart in the single and 1 dart in the double, or 1 dart in the triple #20.]

- This game is played using segments 20, 19, 18, 17, 16, 15, and the Bull's Eye.
- The player who closes a segment may score on that segment until it is closed by all other players.
- On the upper display, the number of a closed segment will be replaced by dashes (--).
- The game ends when one player has closed out all the segments from 20 through the Bull's Eye and has the highest score or is tied for highest score.

OPTIONS FOR TRADITIONAL CRICKET

Cut Throat Cricket

Objective: Same as Cricket, except that players with closed numbers add points to opposing players with those numbers still open.

- The player who has closed all numbers and has the lowest score wins.

Chance It Cricket

Objective: Same as Traditional Cricket.

- In this variation of Cricket, the dart game picks 6 segments at random (and the Bull's Eye) which players close as in a normal Cricket game.
- All the usual Cricket rules apply.

You Pick It Cricket

Objective: Same as Traditional Cricket.

- In this variation of Cricket, players pick 6 segments (and the Bull's Eye) which they then close as in a normal Cricket game.
- To pick segments, press 6 segments on the target when dashes "--" appear in the overhead display.. Once 6 segments have been chosen, the numbers will appear on the display in descending order.
- All the usual Cricket rules apply.

Mark 21

Objective: Same as Traditional Cricket, but without point scoring.

- In this variation of Cricket, the player who closes marks as in a normal Cricket game first – wins.
- All the usual Cricket rules apply.
- NDA Handicap play available.

TEAM OPTIONS FOR CRICKET

Team: 4 Player; 2 Position

- Players 1 and 3 are Team "1" and their score appears on Player 1 display. Players 2 and 4 are Team "2" and their score appears on Player 2 display.
- After selecting a Cricket game, press Team Play and select 2 Pos. The display will automatically put up a 2 position, 4 player game.

Team: 4 Player; 4 Positions

- Players 1 and 3 are Team "1." Players 2 and 4 are Team "2."
- After selecting a Cricket game (with or without options), press Team Play and select 4 Pos.
- The game will automatically put up a 4 player, 4 position game.
- For Cricket / Cut-Throat, scoring on a number can only begin when all players on a team have closed the number. Scoring only occurs against opposing team members who have not closed the segment. [Example: If Team 2 has #18 closed, and only Player 1 on Team 1 has #18 closed, Team 2 can score on #18 until Player 3 closes the number.]
- The game ends when the members on a team close all segments 20-15 and the Bull's Eye and have highest or lowest points, according to each game's rules.

Hi Score

- Each player throws three darts per round.
- Highest score at the end of the programmed number of rounds, wins the game.

Shanghai

- Player(s) begin by throwing three darts per round.
- The object is to hit each segment in sequence beginning with segment #1, working up to segment #20, and ending with the Bull's Eye. The player with the highest score after 7 rounds or a Shanghai wins the game. Game will prompt player for next segment during each round.
- A "Shanghai" is an automatic win achieved by throwing 3 consecutive scoring darts consisting of a single, a double, and a triple segment in any order. [Example: Player is shooting for 4, 5, 6 in round 4 of a game. Player hits a triple 4 segment, then a single 5 segment, then a double 6 segment: this qualifies as a "Shanghai."]

Rapid Fire™

- Each player begins by throwing at the first segment designated by the game. This number will be flashing in the dot matrix display. The timer starts when the first dart hits the board.
- The second dart must be thrown at the next designated segment. Likewise, the third dart must be thrown at the last designated segment.
- The second and third darts must be thrown prior to the elapse of the timer.
- Only the flashing designated segment can be scored upon.
- Each segment hit is displayed in the left side of the Cricket display.
- Each sector of the target is designated once during the game.
- The highest score after 7 rounds wins.

NDA Handicapping

NDA handicapping (a method set by the National Dart Association) is available in 301, 501, and Cricket games. The method NDA of handicapping used by the game depends on the Programmable Feature setting (see page XX). Either the player's averages, (Points per Dart for '01 games and Marks per Round for Cricket) can be used to calculate starting points or mark values or the players can enter the number of spot darts to be thrown in the handicap round (round 0).

Entering Averages

- Deposit required number of credits.
- Select the '01 or Cricket game option, and players.
- Select Handicap, then NDA.
- Press the middle arrow button to begin entering Points Per Dart (PPD) average for each player (you can also enter the numbers manually on the keypad.) The range for PPD is between 10 and 40. Once you have entered the first player, use the right arrow to advance to the next player.
- The same procedure is used to enter Marks Per Round (MPR) for Cricket games. The range for MPR is between 0 and 9.0. If you assign a MPR value greater than 9.0, the system will automatically change it to the maximum allowable (9.0).
- When all players handicaps have been entered, press Start Game.

Entering Spot darts

- Deposit required number of credits.
- Select the '01 or Cricket game and option.
- Select Handicap, then NDA. The game will prompt you to enter the number of spot darts for Player 1. Select the number, and then advance to player 2 with the next button.
- When all players handicaps have been entered, press Start Game.
- When all players have thrown their spot dart(s), the actual game will begin at round 1.

ADA Neutralizer

ADA Neutralizer handicapping (a method set by the American Darters Association) is **only** available in a **2 Player 301 game (Open In/Out) and 4 Player 2 position Traditional Cricket game (Normal option)**.

- Deposit required number of credits.
- Select the 301 or Cricket game, option, and players.
- Select Handicap, then ADA.
- Enter the average Points Per Dart. The range for PPD is between 10 and 30.
- After you have entered the last players Points Per Dart, select Start Game.

Cricket

The game automatically calculates the cumulative team PPD average, and awards marks to the team with the lowest PPD average. Number of awarded marks will be displayed in Player 1 or Player 2 LED. Enter marks using the target.

Note: No more than 2 marks per segment allowed.

301

The game automatically calculates a point advantage for the player with the lowest PPD average and will display adjusted starting scores.

FEATS READOUT

Each feat will be displayed at the end of the game for a period of 6 seconds. Pressing the Next Feat button will speed the advance to the next feat. Pressing the Prev Feat button will cycle back to feats in reverse. Feats will cycle for two minutes. The Eye² will then prompt you for Same Game or New Game. If you select Same Game you will start a game with all the same options as the previous. If you select New Game you will go back to the Top Game Menu. If nothing is done the Eye² will time out and the display will then return to the ATTRACT mode.

In the event the display of feats was accidentally canceled or the timer expired, the last game's feats may be displayed again. At any time **prior** to throwing the first dart of a new game, you may **enter the word F-E-A-T-S (33287) and then press ENTER**. These steps can be used during the GAME SELECT Mode or during the ATTRACT Mode to retrieve the previously played game's feats, provided 1) power was not interrupted or 2) the game was not put into SLEEP Mode since the last game was played. An error tone will sound if no feat data is found when the game is asked to retrieve it.

'01 FEATS SEQUENCE

Total Points
Total Darts Thrown
Points Per Dart
Points Per Round
Win, Assist
Dart Out
Round Out
Hat Trick, Ton, High Ton
Final Score

CRICKET FEATS SEQUENCE

Total Marks
Total Darts Thrown
Marks Per Round
Win, Assist
Dart Out
Hat Trick, White Horse
Marks
Final Score

TROUBLESHOOTING GUIDE

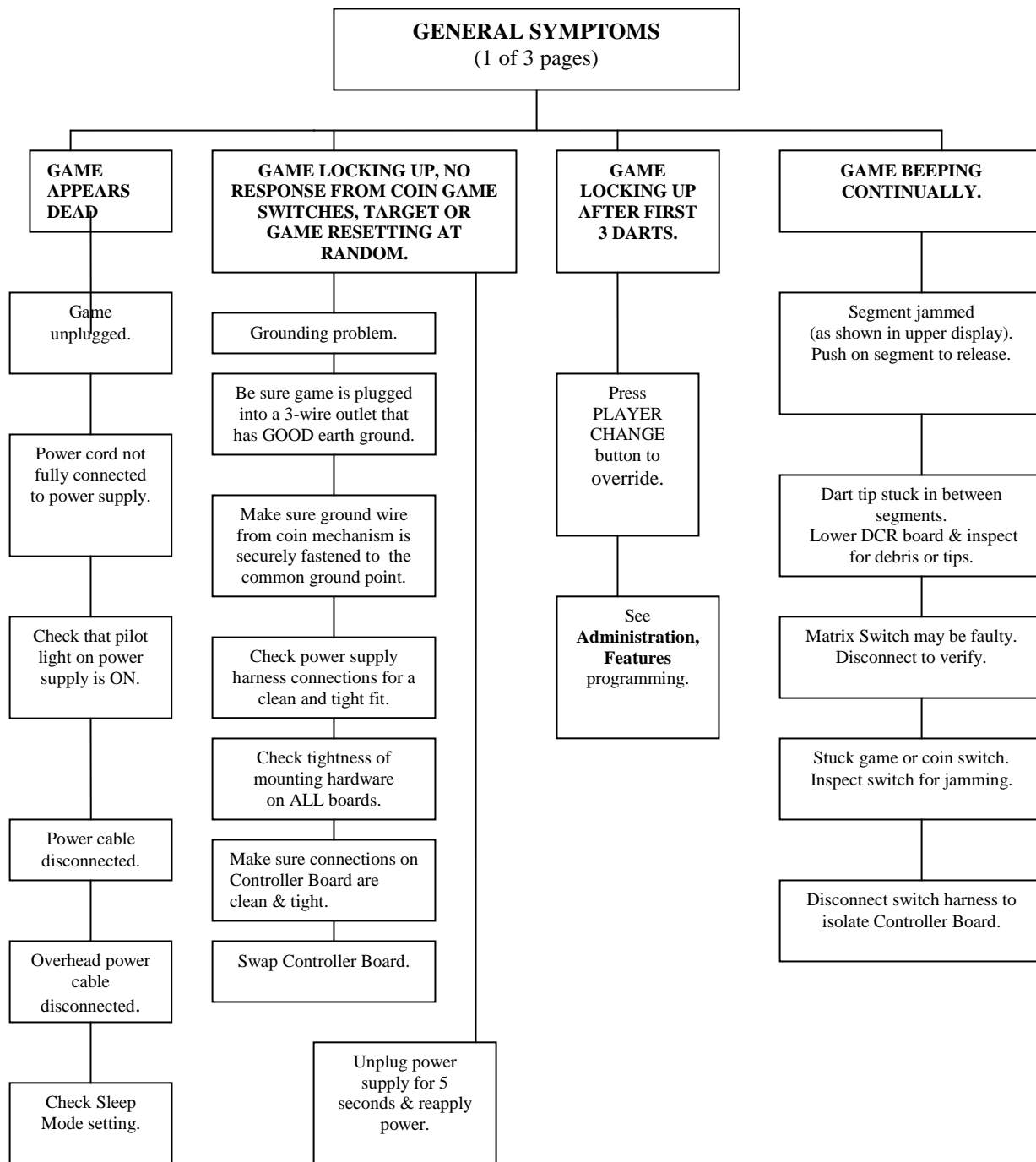

GENERAL SYMPTOMS
(2 of 3 pages)

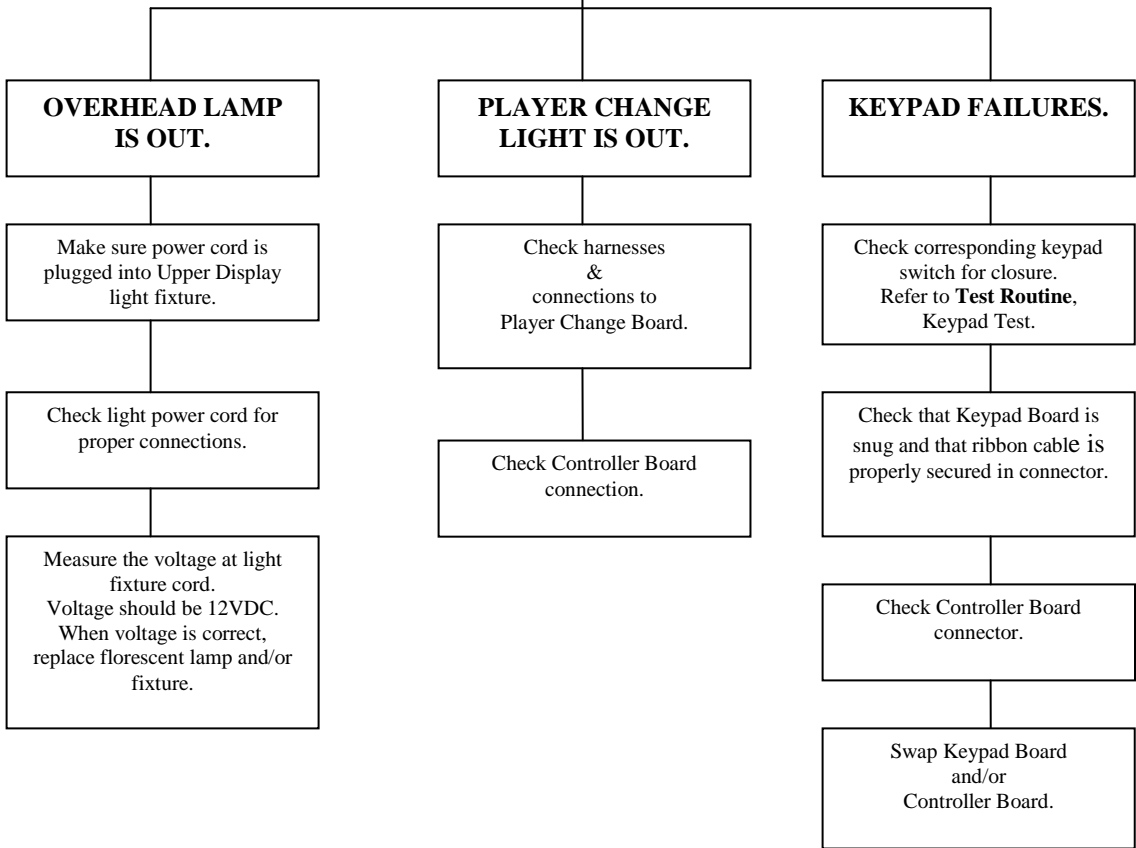

GENERAL SYMPTOMS
(3 of 3 pages)

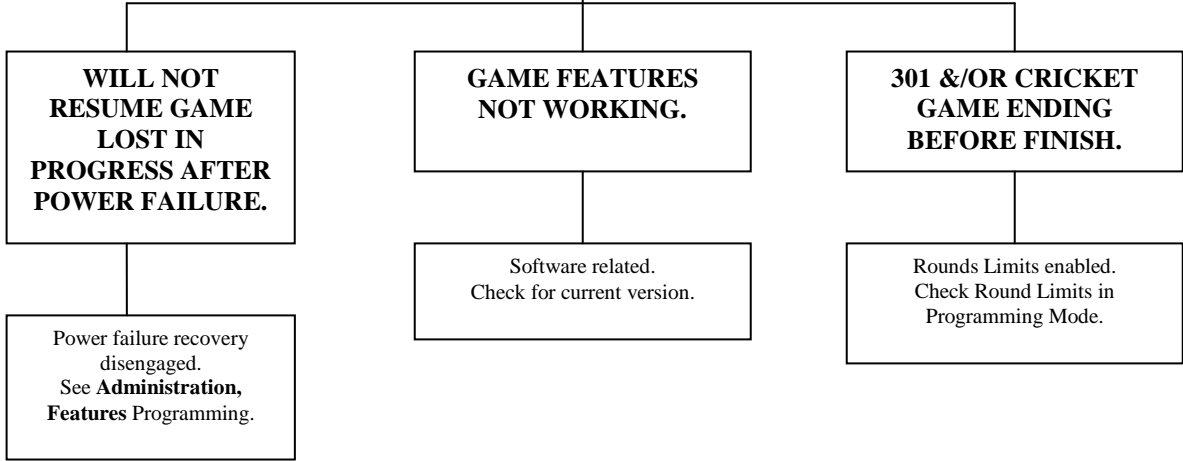

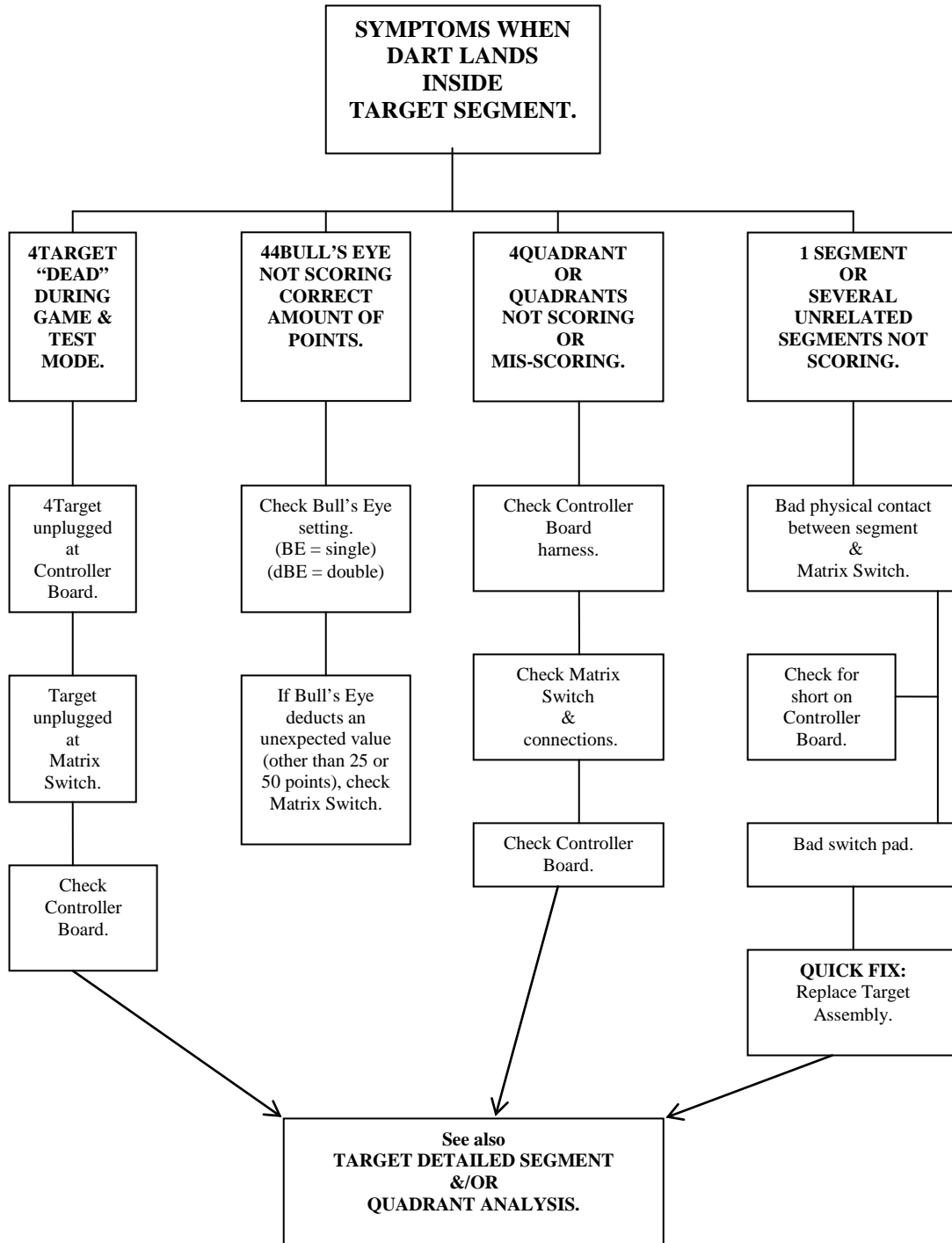

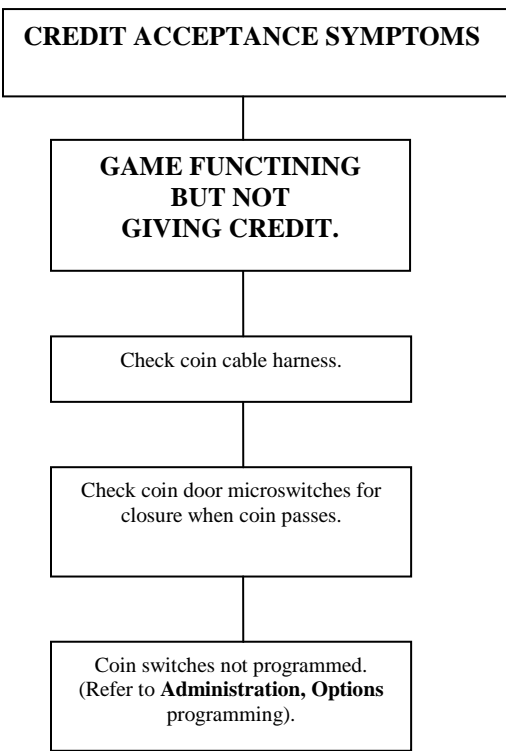
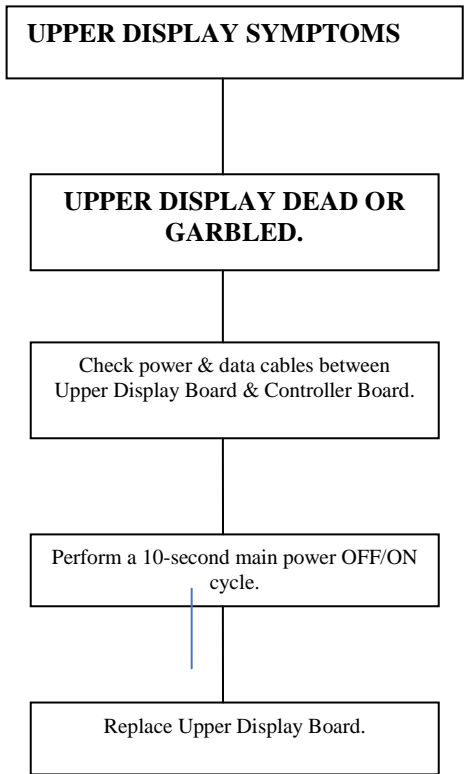

AUTOMATIC PLAYER CHANGE SYMPTOMS

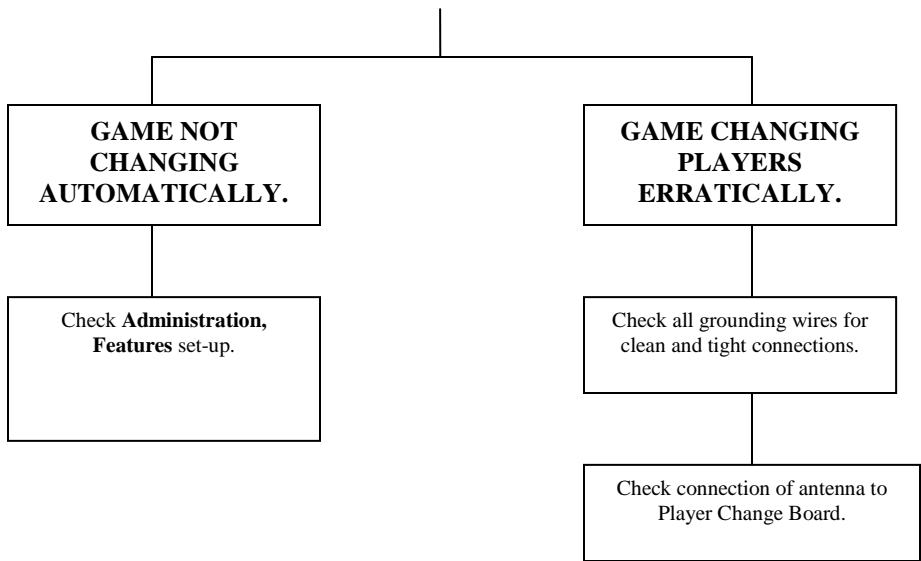

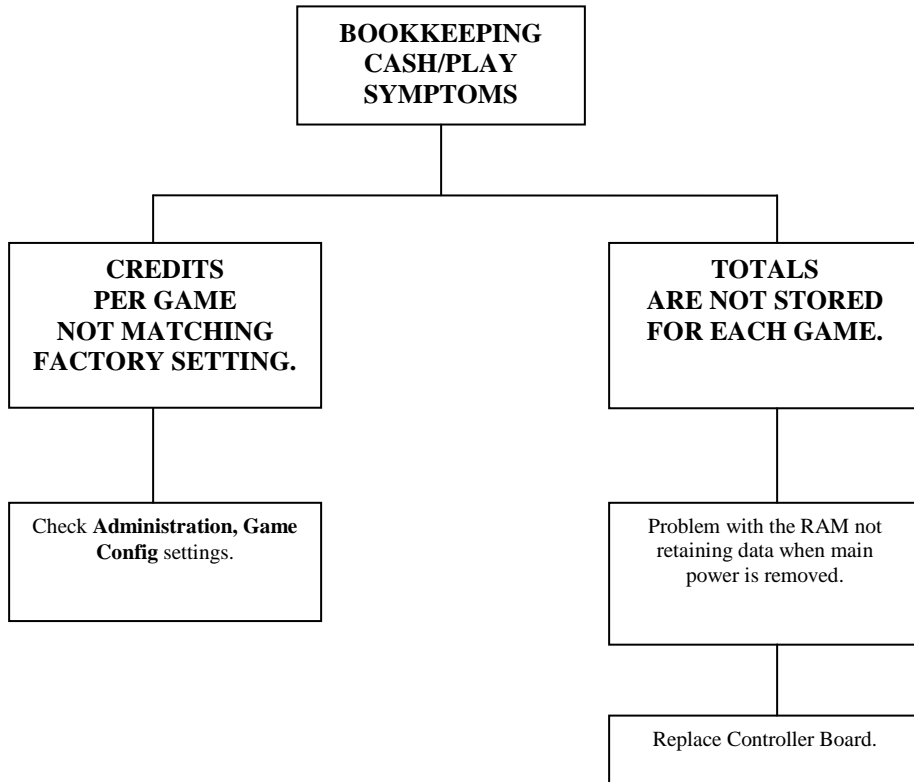
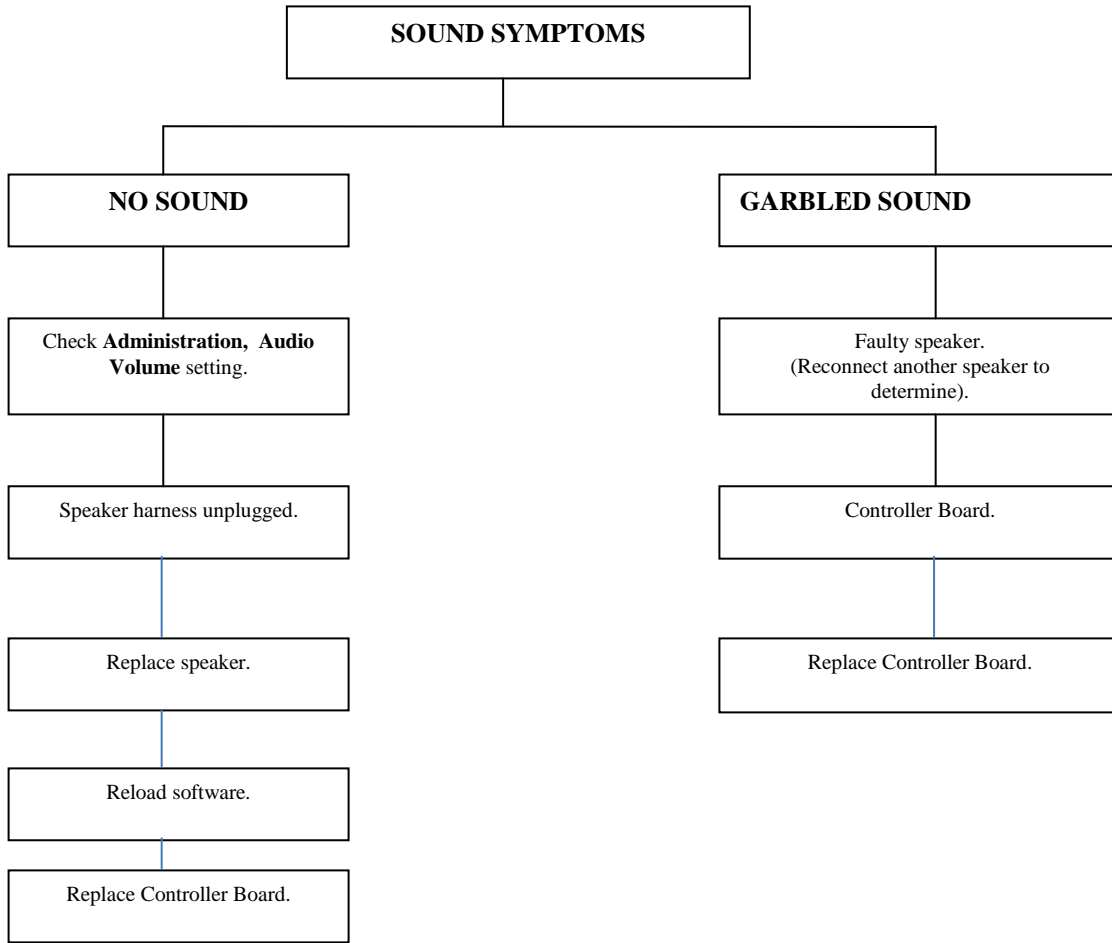

PART'S LIST

SCHEMATICS

DIAGRAMS

NOTE: ALL PART LIST DRAWINGS ARE SHOWN WITHOUT HARNESESSES. See page XX for harness connection routings and part numbers.

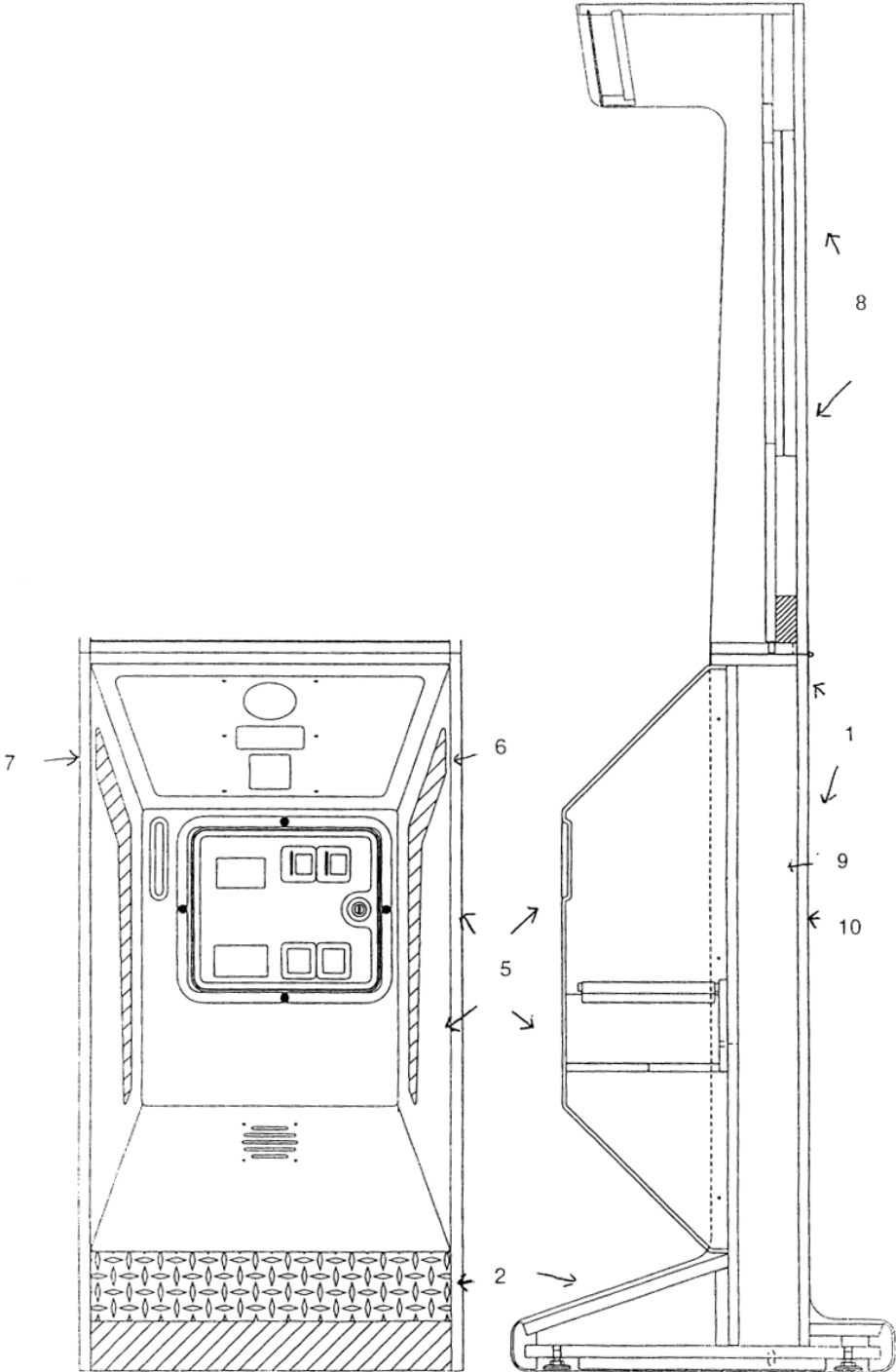

Figure 15 - Overall spare parts list.

PARTS' LIST / SCHEMATICS / DIAGRAMS

SHELTI EYE² SPARE PARTS LIST

<u>ITEM NO.</u>	<u>PART NO.</u>	<u>DESCRIPTION</u>
1	SD-BAD-0	Dart Base Assembly
2	204-0075-0	Dart Base Diamond Plating
3	210-0142-0	Leg Levelers
4	SD-LCD-0	Lower Cabinet
5	210-0210-0	Thumb Bolt Screw - (Qty. 3)
6	SD-BBA-0	Belly Box Assembly
7	217-0004-0	Belly Box Right Side Label
8	217-0005-0	Belly Box Left Side Label
9	SD-UCD-0	Upper Cabinet, wood only
10	H25-1-00-00	Power Supply
11	242-0192-0	Line Cord

NOTE: Target Door shown on page **XX** of Parts List.

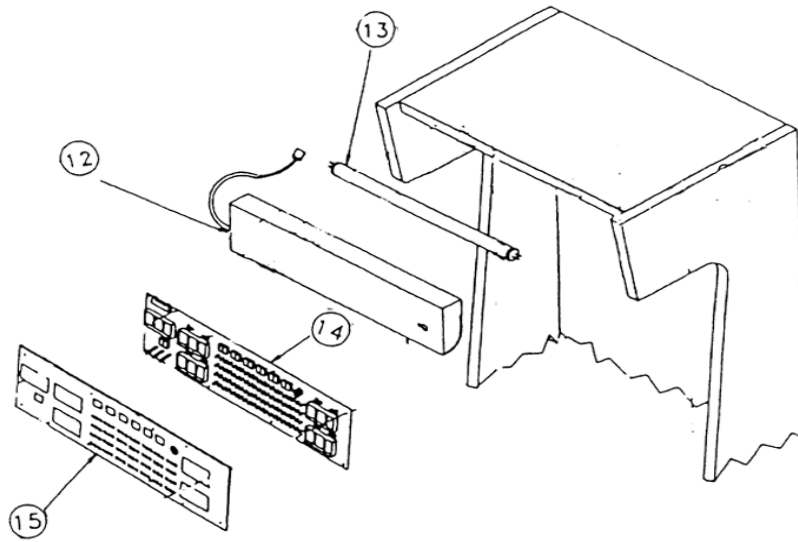

Figure 16 - Upper Display / Lighthouse Assembly.

SHELTI EYE² UPPER DISPLAY / LIGHTHOOD ASSEMBLY PARTS LIST

<u>ITEM NO.</u>	<u>PART NO.</u>	<u>DESCRIPTION</u>
12	J72-0-00-00	Lighthood Assembly
13	201-1103-0	Allen Key Screws
14	GK3-0-00-00	Fluorescent Light Fixture Assembly w/cord
15	223-1013-0	Fluorescent Light Bulb, 12VDC
16	217-0828-0	Fluorescent Light Cord
17	AD1-0-00-00	Upper Display Board
18	205-0969-0	Marquee Panel
19	201-0056-0	8-32 x 5/8 Black Machine Screw - (Qty 5)

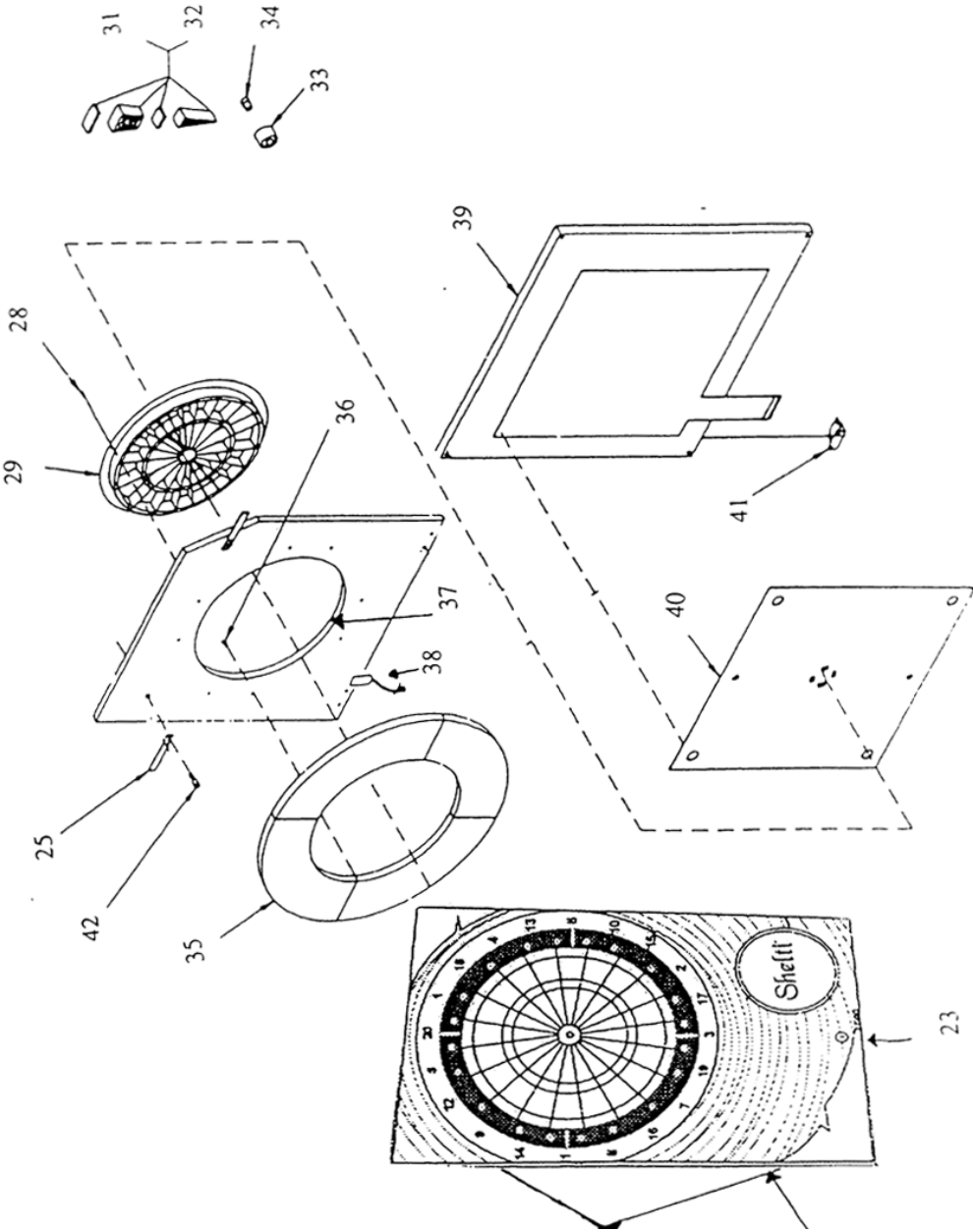

Figure 17 - Target Assembly

SHELTI EYE² TARGET ASSEMBLY

<u>ITEM NO.</u>	<u>PART NO.</u>	<u>DESCRIPTION</u>
20	206-0289-0	Dart Door Latch
21	SD-UDO-0	Dart Door Assembly
22	217-0003-0	Dart Door Graphics Panel
23	306-0003-0	Target Door Lock
24	N73-1-00-00	Target Assembly American, Red & Blue
25	206-0279-0	Matrix Switch Latch - (Qty 2)
26	201-0213-0	Particle Board Screw, Black – (Qty 2)
27	N25-1-00-00	Spider Assembly American, Red & Blue
28	201-1052-0	8-32 x 3/8 Pan Head Machine Screw – (Qty 2)
29	205-1222-10	Spider, American, White
30	Q17-3-00-00	82pc Segment Set, Red & Blue
31	Q28-2-00-00	4pc Segment Set, Red
32	Q29-3-00-00	4pc Segment Set, Blue
33	205-0340-1	Outer Bull's-Eye, Blue
34	205-1221-7	Inner Bull's Eye, Red
35	205-1022-6	Dart Catching Ring
36	201-0100-0	8-7/8 Sheet Metal Screw – (Qty 16)
37	205-0798-0	Catch Ring T-molding
38	217-0273-0	Piezo Film
39	N65-1-00-00	Matrix Switch Assembly, American
40	207-0048-5	Rubber Sheet, American
41	206-0272-0	Target Hinge – (Qty 2)
42	201-0111-0	1/4 -20 x 1 9/32 Adj. Screw – (Qty 4)
43	AD2-0-00-00	Dart Interface Board

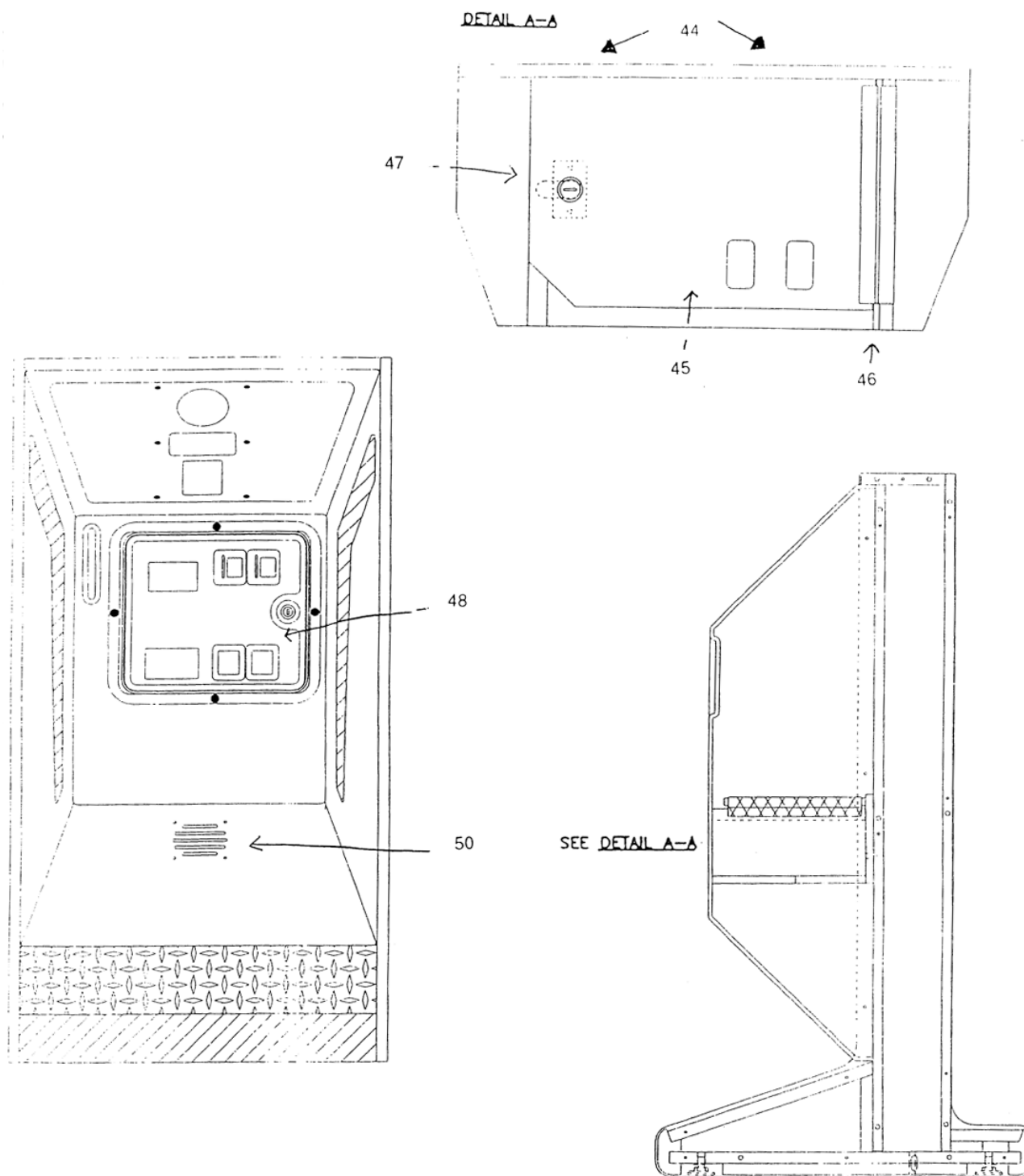

Figure 18 - Base Coin Box Detail

SHELTI EYE² BASE COIN BOX DETAIL

<u>ITEM NO.</u>	<u>PART NO.</u>	<u>DESCRIPTION</u>
44	SD-CBA-0	Cash Box Assembly
45	103-0082-0	Cash Box Top Wood
46	201-0150-0	Hinge Cash Box Cover
47	306-0005-0	Cash Box Lock
48	210-0207-0	Coin Door Assembly
49	201-0073-0	Cash Box
50	GK2-0-00-00	Speaker Assembly w/2 pin connector harness

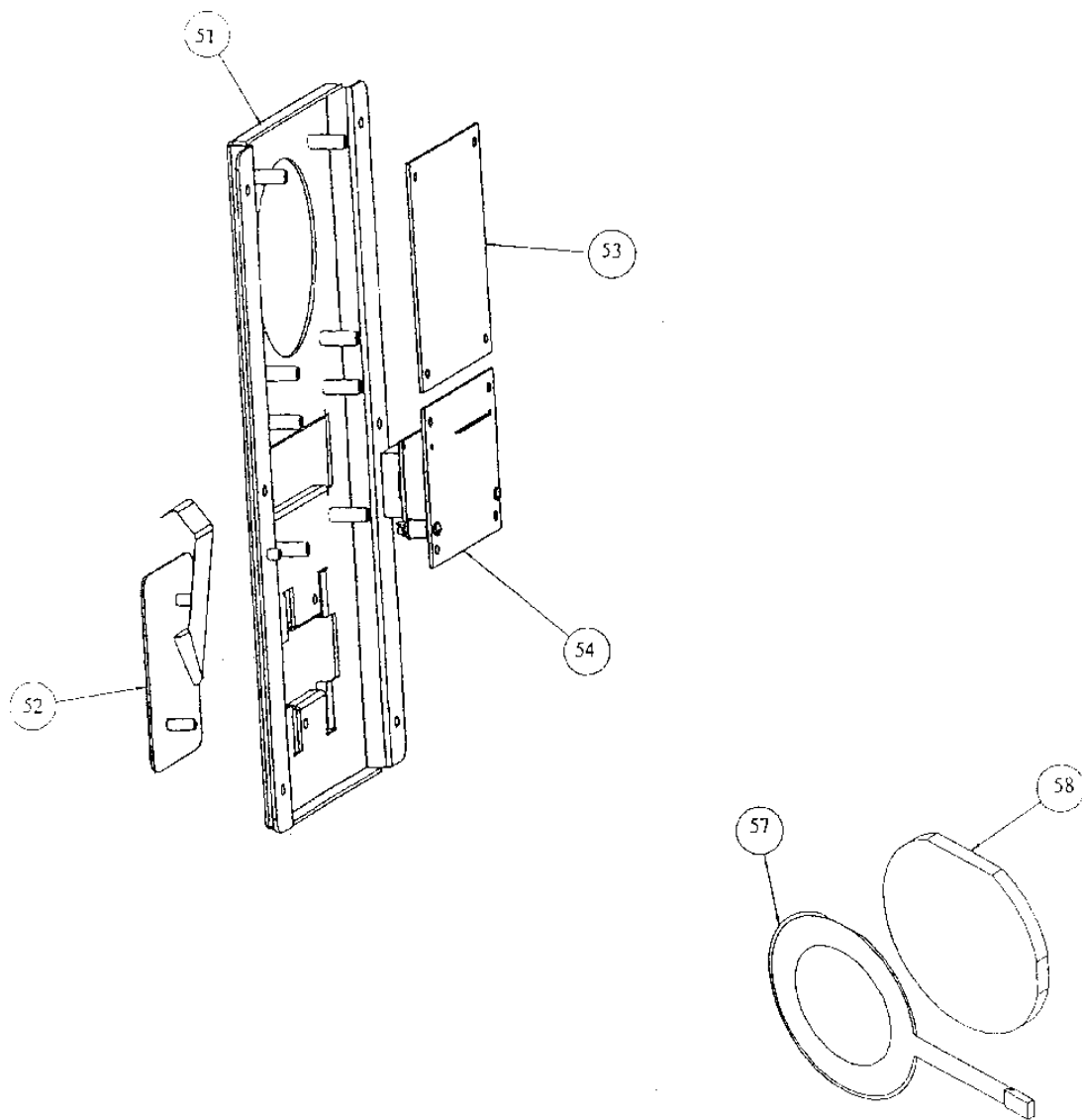

Figure 19 - User Interface Detail

SHELTI EYE² USER INTERFACE DETAIL

<u>ITEM NO.</u>	<u>PART NO.</u>	<u>DESCRIPTION</u>
51	GK4-0-00-00	Control Panel Assembly
52	GH9-0-00-00	Keypad Assembly
53	GK1-0-00-00	Player Change Sensor Board
54	AD4-0-00-00	LCD Assembly
55	E5F-0-00-00	Interconnect Harness, Player Change & LCD
56	E5G-0-00-00	Ground Harness, LCD
57	217-0829-0	Player Change Sensor Antenna
58	205-0973-0	Player Change Lens
59	205-0970-0	Overlay, Control Panel
60	202-1014-0	Black Oxide Bolts – (Qty 6)
61	203-1033-0	Thumb Nut
62	203-1032-0	1/2” Nut for Bolts

SHELTI EYE² CABLES AND HARNESS PARTS LIST

PART NO.	DESCRIPTION
E5A-0-00-00	Upper Display Power Cable w/ferrite bead
E5B-0-00-00	Upper Display Comm. Cable
E5C-0-00-00	Cable, Control Panel, 26 pin
GH8-0-00-00	Coin Switch Harness
205-1007-0	Tie Anchor Mount
244-0016-0	Ferrite bead

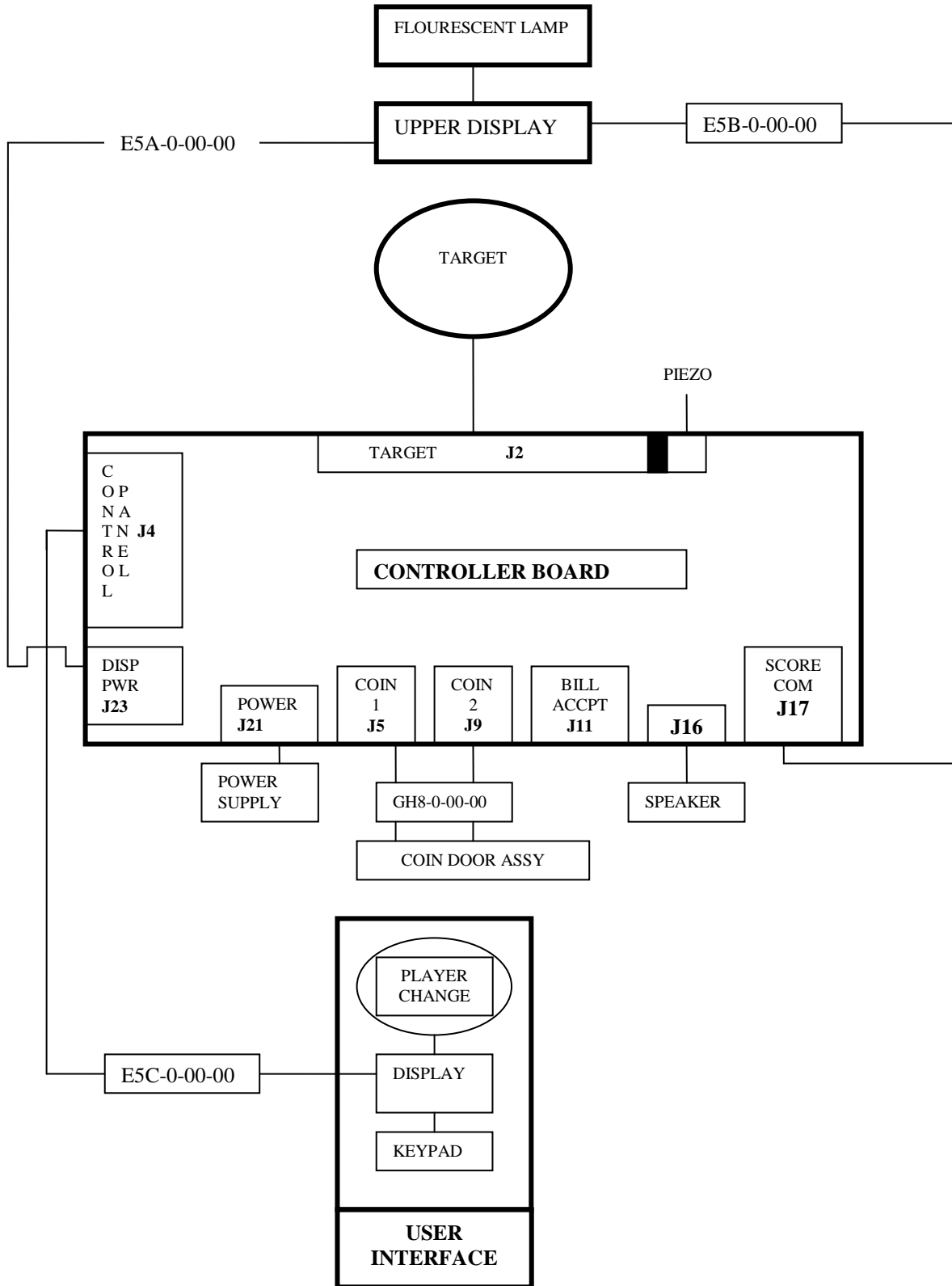

Figure 20 - System Diagram

LIST OF FIGURES

List of Figures

Figure 1. Game in Shipped Position	
Figure 2. Shelti Eye2 Front View	
Figure 3. Stability Assurance Kit	
Figure 4. Eye bolt and chain fastened to game	
Figure 5. Toggle bolt close-up	
Figure 6. Close-up toggle bolt installed	
Figure 7. Fasten to concrete, brick, or stone wall	
Figure 8. Fasten to wood stud	
Figure 9. Floor layout	
Figure 10. Fasten to concrete floor	
Figure 11. Fasten to wood floor	
Figure 12. Game Select Panel	
Figure 13. Missed Dart Sensing Areas	
Figure 14. Controller Board	
Figure 15. Overall spare parts list	
Figure 16. Upper Display / Lighthood Assembly	
Figure 17. Target Assembly	
Figure 18. Base coin box detail	
Figure 19. User Interface Detail	
Figure 20. System Diagram	