



LU935ST

Projector RS232 Command Control

Installation Guide

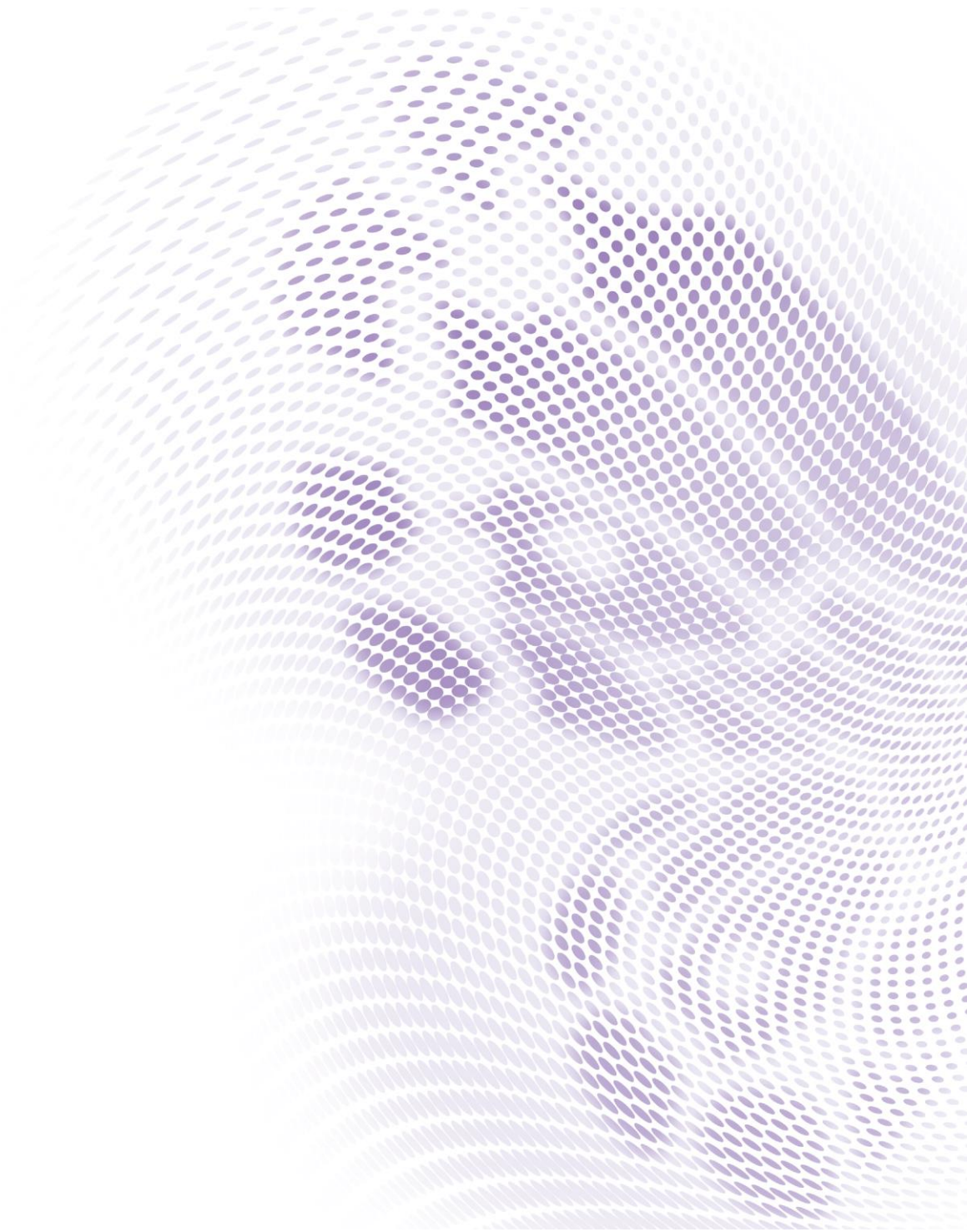

Table of Contents

Introduction	3
Wire arrangement.....	3
RS232 pin assignment.....	3
Connections and communication settings	4
RS232 serial port with a crossover cable	4
Settings	4
RS232 via LAN.....	6
Settings	6
RS232 via HDBaseT.....	6
Settings	6
Command table.....	8

Introduction

The document describes how to control your BenQ projector via RS232 from a computer. Follow the procedures to complete the connection and settings first, and refer to the command table for RS232 commands.



Available functions and commands vary by model. Check the specifications and user manual of the purchased projector for product functions.

Wire arrangement

Wire Arrangement		
P1	Color	P2
1	Black	1
2	Brown	3
3	Red	2
4	Orange	4
5	Yellow	5
6	Green	6
7	Blue	7
8	Purple	8
9	Gray	9
Case	Drain wire	Case

RS232 pin assignment



Pin	Description	Pin	Description
1	NC	2	RXD
3	TXD	4	NC
5	GND	6	NC
7	RTS	8	CTS
9	NC		

Connections and communication settings

Choose one of the connections and set up properly before RS232 control.

RS232 serial port with a crossover cable

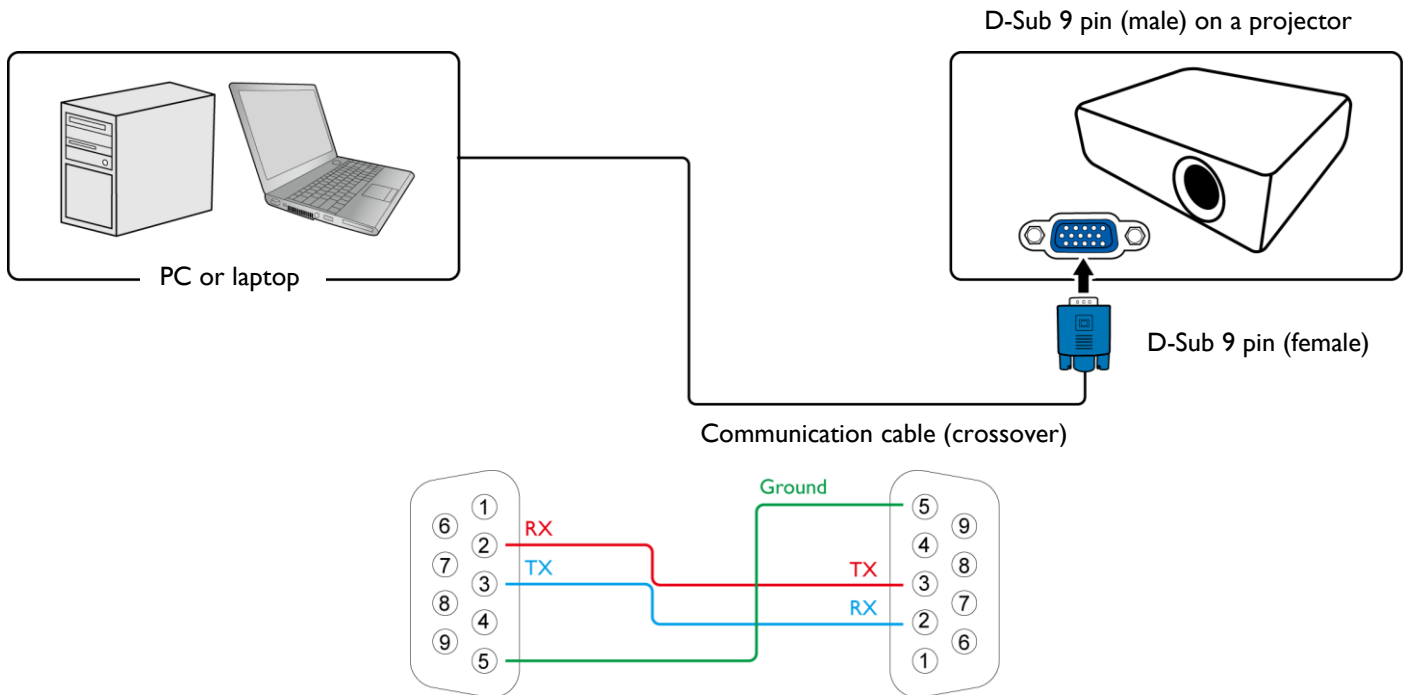

Settings

 On-screen images in this document are for reference only. The screens may vary depending on your Operating System, I/O ports used for connection, and the specifications of the connected projector.

- I. Determine the COM Port name used for the RS232 communications in **Device Manager**.

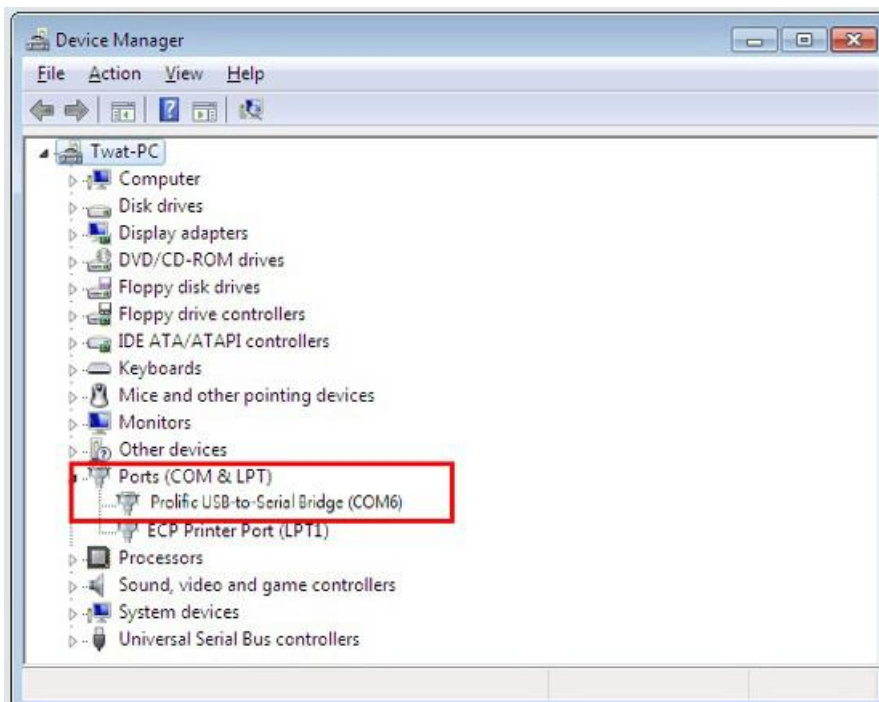

2. Choose **Serial** and the corresponding COM port as the communication port. In this given example, COM6 is selected.



3. Finish **Serial port setup**.

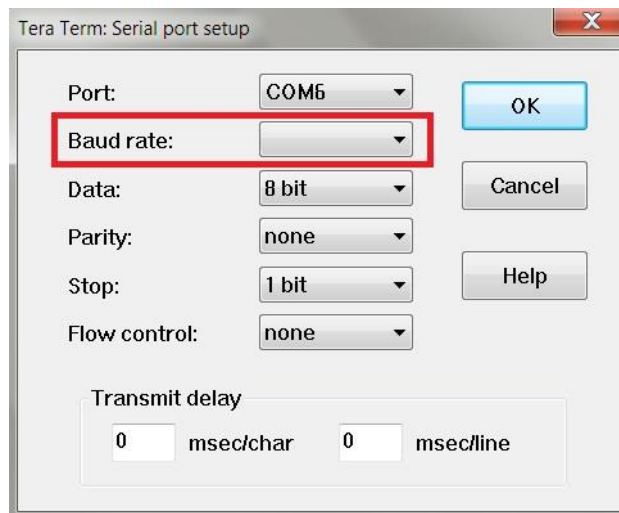

Baud rate	9600 / 14400 / 19200 / 38400 / 57600 / 115200 bps  Check the baud rate of the connected projector from its OSD menu.
Data length	8 bit
Parity check	None
Stop bit	1 bit
Flow control	None

RS232 via LAN



Settings

1. Find the Wired LAN IP address of the connected projector from the OSD menu and make sure the projector and the computer are within the same network.
2. Input **8000** in the **TCP port #** field.



RS232 via HDBaseT

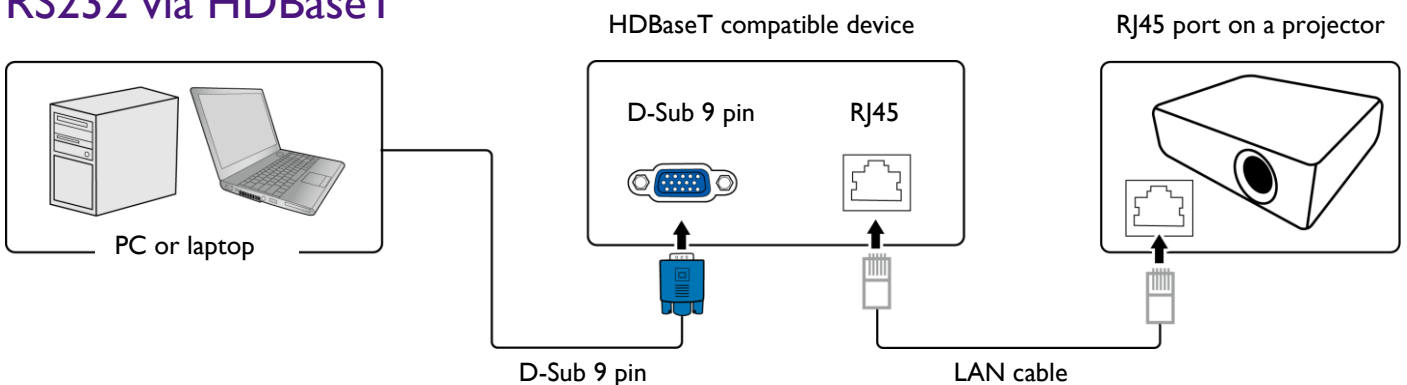

Settings

1. Determine the COM Port name used for the RS232 communications in **Device Manager**.
2. Choose **Serial** and the corresponding COM port as the communication port. In this given example, COM6 is selected.



3. Finish **Serial** port setup.



Baud rate	9600 / 14400 / 19200 / 38400 / 57600 / 115200 bps  Check the baud rate of the connected projector from its OSD menu.
Data length	8 bit
Parity check	None
Stop bit	1 bit
Flow control	None

Command table



- Available features differ by projector specification, input sources, settings, etc..
- Commands are working if the standby power is 0.5W or a supported baud rate of the projector is set.
- Uppercase, lowercase, and a mixture of both types of characters are accepted for a command.
- If a command format is illegal, it will echo **Illegal format**.
- If a command with correct format is not valid for the projector model, it will echo **Unsupported item**.
- If a command with correct format cannot be executed under certain condition, it will echo **Block item**.
- If RS232 control is performed via LAN, a command works whether it starts and ends with **<CR>**. All the commands and behaviors are identical with the control through a serial port.

Function	Type	Operation	ASCII	Support
Power	Write	Power On	<CR>*pow=on#<CR>	YES
	Write	Power Off	<CR>*pow=off#<CR>	YES
	Read	Power Status	<CR>*pow=?#<CR>	YES
Source Selection	Write	COMPUTER/YPbPr	<CR>*sour=RGB#<CR>	YES
	Write	COMPUTER 2/YPbPr2	<CR>*sour=RGB2#<CR>	NO
	Write	COMPUTER 3/YPbPr3	<CR>*sour=RGB3#<CR>	NO
	Write	Component	<CR>*sour=ypr#<CR>	NO
	Write	Component2	<CR>*sour=ypr2#<CR>	NO
	Write	DVI-A	<CR>*sour=dviA#<CR>	NO
	Write	DVI-D	<CR>*sour=dvid#<CR>	NO
	Write	HDMI(MHL)	<CR>*sour=hdmi#<CR>	YES
	Write	HDMI 2(MHL2)	<CR>*sour=hdmi2#<CR>	YES
	Write	HDMI 3	<CR>*sour=hdmi3#<CR>	NO
	Write	Composite	<CR>*sour=vid#<CR>	NO
	Write	S-Video	<CR>*sour=svid#<CR>	NO
	Write	Network	<CR>*sour=network#<CR>	NO
	Write	USB Display	<CR>*sour=usbdisplay#<CR>	NO
	Write	USB Reader	<CR>*sour=usbreader#<CR>	NO
	Write	HDbaseT	<CR>*sour=hdbaset#<CR>	YES
	Write	DisplayPort	<CR>*sour=dp#<CR>	NO
	Write	3G-SDI	<CR>*sour=sdi#<CR>	NO
Write	Smart System	<CR>*sour=smartsystem#<CR>	NO	
Read	Current source	<CR>*sour=?#<CR>	YES	
Audio Control	Write	Mute On	<CR>*mute=on#<CR>	YES
	Write	Mute Off	<CR>*mute=off#<CR>	YES
	Read	Mute Status	<CR>*mute=?#<CR>	YES

	Write	Volume +	<CR>*vol=+#<CR>	YES
	Write	Volume -	<CR>*vol=-#<CR>	YES
	Write	Volume level for customer	<CR>*vol=value#<CR>	YES
	Read	Volume Status	<CR>*vol=?#<CR>	YES
	Write	Mic.Volume +	<CR>*micvol=+#<CR>	NO
	Write	Mic.Volume -	<CR>*micvol=-#<CR>	NO
	Read	Mic.Volume Status	<CR>*micvol=?#<CR>	NO
Audio source select	Write	Audio pass Through off	<CR>*audiosour=off#<CR>	YES
	Write	Audio-Computer 1	<CR>*audiosour=RGB#<CR>	YES
	Write	Audio-Computer2	<CR>*audiosour=RGB2#<CR>	NO
	Write	Audio-Video/S-Video	<CR>*audiosour=vid#<CR>	NO
	Write	Audio-Component	<CR>*audiosour=ypbr#<CR>	NO
	Write	Audio-HDMI	<CR>*audiosour=hdmi#<CR>	YES
	Write	Audio-HDMI2	<CR>*audiosour=hdmi2#<CR>	YES
	Write	Audio-HDMI3	<CR>*audiosour=hdmi3#<CR>	NO
	Read	Audio pass Status	<CR>*audiosour=?#<CR>	YES
Picture Mode	Write	Dynamic	<CR>*appmod=dynamic#<CR>	NO
	Write	Presentation	<CR>*appmod=preset#<CR>	YES
	Write	sRGB	<CR>*appmod=srgb#<CR>	YES
	Write	Bright	<CR>*appmod=bright#<CR>	YES
	Write	Living Room	<CR>*appmod=livingroom#<CR>	NO
	Write	Game	<CR>*appmod=game#<CR>	NO
	Write	Cinema(Rec.709)	<CR>*appmod=cine#<CR>	NO
	Write	Standard	<CR>*appmod=std#<CR>	NO
	Write	Video	<CR>*appmod=video#<CR>	YES
	Write	Football	<CR>*appmod=football#<CR>	NO
	Write	Football Bright	<CR>*appmod=footballbt#<CR>	NO
	Write	DICOM	<CR>*appmod=dicom#<CR>	YES
	Write	THX	<CR>*appmod=thx#<CR>	NO
	Write	Silence mode	<CR>*appmod=silence#<CR>	NO
	Write	DCI-P3 mode(D. Cinema)	<CR>*appmod=dci-p3#<CR>	NO
	Write	Vivid	<CR>*appmod=vivid#<CR>	NO
	Write	Infographic	<CR>*appmod=infographic#<CR>	YES
	Write	User 1	<CR>*appmod=user 1#<CR>	YES
	Write	User2	<CR>*appmod=user2#<CR>	YES
	Write	User3	<CR>*appmod=user3#<CR>	NO

	Write	ISF Day	<CR>*appmod=isfday#<CR>	NO
	Write	ISF Night	<CR>*appmod=isfnight#<CR>	NO
	Write	3D	<CR>*appmod=threed#<CR>	YES
	Write	Sport	<CR>*appmod=sport#<CR>	NO
	Write	HDR	<CR>*appmod=hdr#<CR>	YES
	Write	HLG	<CR>*appmod=hlg#<CR>	YES
	Read	Picture Mode	<CR>*appmod=?#<CR>	YES
Picture Setting	Write	Contrast +	<CR>*con=+#<CR>	YES
	Write	Contrast -	<CR>*con=-#<CR>	YES
	Write	Set Contrast value	<CR>*con=value#<CR>	YES
	Read	Contrast value	<CR>*con=?#<CR>	YES
	Write	Brightness +	<CR>*bri=+#<CR>	YES
	Write	Brightness -	<CR>*bri=-#<CR>	YES
	Write	Set Brightness value	<CR>*bri=value#<CR>	YES
	Read	Brightness value	<CR>*bri=?#<CR>	YES
	Write	Color +	<CR>*color=+#<CR>	YES
	Write	Color -	<CR>*color=-#<CR>	YES
	Write	Set Color value	<CR>*color=value#<CR>	YES
	Read	Color value	<CR>*color=?#<CR>	YES
	Write	Sharpness +	<CR>*sharp=+#<CR>	YES
	Write	Sharpness -	<CR>*sharp=-#<CR>	YES
	Write	Set Sharpness value	<CR>*sharp=value#<CR>	YES
	Read	Sharpness value	<CR>*sharp=?#<CR>	YES
	Write	Flesh Tone +	<CR>*fleshtone=+#<CR>	NO
	Write	Flesh Tone -	<CR>*fleshtone=-#<CR>	NO
	Write	Set Flesh Tone value	<CR>*fleshtone=value#<CR>	NO
	Read	Flesh Tone value	<CR>*fleshtone=?#<CR>	NO
	Write	Color Temperature-Warmer	<CR>*ct=warmer#<CR>	NO
	Write	Color Temperature-Warm	<CR>*ct=warm#<CR>	YES
	Write	Color Temperature-Normal	<CR>*ct=normal#<CR>	YES
	Write	Color Temperature-Cool	<CR>*ct=cool#<CR>	YES
	Write	Color Temperature-Cooler	<CR>*ct=cooler#<CR>	NO
Write	Color	<CR>*ct=ative#<CR>	NO	

	Temperature-lamp native		
Read	Color Temperature Status	<CR>*ct=?#<CR>	YES
Write	Aspect 4:3	<CR>*asp=4:3#<CR>	YES
Write	Aspect 16:6	<CR>*asp=16:6#<CR>	NO
Write	Aspect 16:9	<CR>*asp=16:9#<CR>	YES
Write	Aspect 16:10	<CR>*asp=16:10#<CR>	YES
Write	Aspect 2.35:1	<CR>*asp=2.4:1#<CR>	YES
Write	Aspect Auto	<CR>*asp=AUTO#<CR>	YES
Write	Aspect Real	<CR>*asp=REAL#<CR>	YES
Write	Aspect Letterbox	<CR>*asp=LBOX#<CR>	NO
Write	Aspect Wide	<CR>*asp=WIDE#<CR>	NO
Write	Aspect Anamorphic	<CR>*asp=ANAM#<CR>	NO
Write	Aspect Anamorphic 2.35	<CR>*asp=ANAM2.35#<CR>	NO
Write	Aspect Anamorphic 16:9	<CR>*asp=ANAM16:9#<CR>	NO
Read	Aspect Status	<CR>*asp=?#<CR>	YES
Write	Vertical Keystone +	<CR>*vkeystone=+#<CR>	YES
Write	Vertical Keystone -	<CR>*vkeystone=-#<CR>	YES
Read	Vertical Keystone value	<CR>*vkeystone=?#<CR>	YES
Write	Horizontal Keystone +	<CR>*hkeystone=+#<CR>	YES
Write	Horizontal Keystone -	<CR>*hkeystone=-#<CR>	YES
Read	Horizontal Keystone value	<CR>*hkeystone=?#<CR>	YES
Write	Overscan Adjustment +	<CR>*overscan=+#<CR>	NO
Write	Overscan Adjustment -	<CR>*overscan=-#<CR>	NO
Read	Overscan Adjustment value	<CR>*overscan=?#<CR>	NO
Write	4 Corners Top-Left-X Decrease	<CR>*cornerfittlx=-#<CR>	YES
Write	4 Corners Top-Left-X Increase	<CR>*cornerfittlx=+#<CR>	YES
Read	4 Corners Top-Left-X Status	<CR>*cornerfittlx=?#<CR>	YES
Write	4 Corners Top-Left-Y Decrease	<CR>*cornerfittly=-#<CR>	YES

	Write	4 Corners Top-Left-Y Increase	<CR>*cornerfittly=+#<CR>	YES
	Read	4 Corners Top-Left-Y Status	<CR>*cornerfittly=?#<CR>	YES
	Write	4 Corners Top-Right-X Decrease	<CR>*cornerfittrx=-#<CR>	YES
	Write	4 Corners Top-Right-X Increase	<CR>*cornerfittrx=+#<CR>	YES
	Read	4 Corners Top-Right-X Status	<CR>*cornerfittrx=?#<CR>	YES
	Write	4 Corners Top-Right-Y Decrease	<CR>*cornerfittry=-#<CR>	YES
	Write	4 Corners Top-Right-Y Increase	<CR>*cornerfittry=+#<CR>	YES
	Read	4 Corners Top-Right-Y Status	<CR>*cornerfittry=?#<CR>	YES
	Write	4 Corners Bottom-Left-X Decrease	<CR>*cornerfitblx=-#<CR>	YES
	Write	4 Corners Bottom-Left-X Increase	<CR>*cornerfitblx=+#<CR>	YES
	Read	4 Corners Bottom-Left-X Status	<CR>*cornerfitblx=?#<CR>	YES
	Write	4 Corners Bottom-Left-Y Decrease	<CR>*cornerfitbly=-#<CR>	YES
	Write	4 Corners Bottom-Left-Y Increase	<CR>*cornerfitbly=+#<CR>	YES
	Read	4 Corners Bottom-Left-Y Status	<CR>*cornerfitbly=?#<CR>	YES
	Write	4 Corners Bottom-Right-X Decrease	<CR>*cornerfitbrx=-#<CR>	YES
	Write	4 Corners Bottom-Right-X Increase	<CR>*cornerfitbrx=+#<CR>	YES
Read	4 Corners Bottom-Right-X Status	<CR>*cornerfitbrx=?#<CR>	YES	

	Write	4 Corners Bottom-Right-Y Decrease	<CR>*cornerfitbry=-#<CR>	YES
	Write	4 Corners Bottom-Right-Y Increase	<CR>*cornerfitbry=+#<CR>	YES
	Read	4 Corners Bottom-Right-Y Status	<CR>*cornerfitbry=?#<CR>	YES
	Write	Digital Zoom In	<CR>*zoomI#<CR>	YES
	Write	Digital Zoom out	<CR>*zoomO#<CR>	YES
	Write	Auto	<CR>*auto#<CR>	YES
	Write	Brilliant color on	<CR>*BC=on#<CR>	YES
	Write	Brilliant color off	<CR>*BC=off#<CR>	YES
	Read	Brilliant color status	<CR>*BC=?#<CR>	YES
	Write	Auto(HDR)	<CR>*hdr=auto#<CR>	YES
	Write	SDR	<CR>*hdr=sdr#<CR>	YES
	Write	HDR10	<CR>*hdr=hdr#<CR>	YES
	Write	HLG	<CR>*hdr=hlg#<CR>	YES
	Read	HDR status	<CR>*hdr=?#<CR>	YES
	Write	Reset current picture settings	<CR>*rstcurpicsetting#<CR>	NO
Write	Reset all picture settings	<CR>*rstallpicsetting#<CR>	NO	
Operation Settings	Write	Projector Position-Front Table	<CR>*pp=FT#<CR>	YES
	Write	Projector Position-Rear Table	<CR>*pp=RE#<CR>	YES
	Write	Projector Position-Rear Ceiling	<CR>*pp=RC#<CR>	YES
	Write	Projector Position-Front Ceiling	<CR>*pp=FC#<CR>	YES
	Read	Projector Position Status	<CR>*pp=?#<CR>	YES
	Write	Quick cooling on	<CR>*qcool=on<CR>	NO
	Write	Quick cooling off	<CR>*qcool=off<CR>	NO
	Read	Quick cooling status	<CR>*qcool=?<CR>	NO
	Write	Quick auto search	<CR>*QAS=on#<CR>	YES
	Write	Quick auto search	<CR>*QAS=off#<CR>	YES
	Read	Quick auto search	<CR>*QAS=?#<CR>	YES

		status		
	Write	Menu Position - Center	<CR>*menuposition=center#<CR>	NO
	Write	Menu Position - Top-Left	<CR>*menuposition=tl#<CR>	NO
	Write	Menu Position - Top-Right	<CR>*menuposition=tr#<CR>	NO
	Write	Menu Position - Bottom-Right	<CR>*menuposition=br#<CR>	NO
	Write	Menu Position - Bottom-Left	<CR>*menuposition=bl#<CR>	NO
	Read	Menu Position Status	<CR>*menuposition=?#<CR>	NO
	Write	Direct Power On-on	<CR>*directpower=on#<CR>	YES
	Write	Direct Power On-off	<CR>*directpower=off#<CR>	YES
	Read	Direct Power On-Status	<CR>*directpower=?#<CR>	YES
	Write	Signal Power On-on	<CR>*autopower=on#<CR>	YES
	Write	Signal Power On-off	<CR>*autopower=off#<CR>	YES
	Read	Signal Power On-Status	<CR>*autopower=?#<CR>	YES
	Write	Standby Settings-Network on	<CR>*standbynet=on#<CR>	NO
	Write	Standby Settings-Network off	<CR>*standbynet=off#<CR>	NO
	Read	Standby Settings-Network Status	<CR>*standbynet=?#<CR>	NO
	Write	Standby Settings-Microphone on	<CR>*standbymic=on#<CR>	NO
	Write	Standby Settings-Microphone off	<CR>*standbymic=off#<CR>	NO
	Read	Standby Settings-Microphone Status	<CR>*standbymic=?#<CR>	NO
	Write	Standby Settings-Monitor Out on	<CR>*standbymnt=on#<CR>	NO
	Write	Standby Settings-Monitor Out off	<CR>*standbymnt=off#<CR>	NO
	Read	Standby	<CR>*standbymnt=?#<CR>	NO

		Settings-Monitor Out Status		
Baud Rate	Write	2400	<CR>*baud=2400#<CR>	NO
	Write	4800	<CR>*baud=4800#<CR>	NO
	Write	9600	<CR>*baud=9600#<CR>	YES
	Write	14400	<CR>*baud=14400#<CR>	YES
	Write	19200	<CR>*baud=19200#<CR>	YES
	Write	38400	<CR>*baud=38400#<CR>	YES
	Write	57600	<CR>*baud=57600#<CR>	YES
	Write	115200	<CR>*baud=115200#<CR>	YES
	Read	Current Baud Rate	<CR>*baud=?#<CR>	YES
Lamp Control	Read	Lamp	<CR>*ltim=?#<CR>	YES
	Read	Lamp2 Hour	<CR>*ltim2=?#<CR>	NO
	Write	Normal mode	<CR>*lampm=lnor#<CR>	YES
	Write	Eco mode	<CR>*lampm=eco#<CR>	YES
	Write	SmartEco mode	<CR>*lampm=seco#<CR>	NO
	Write	SmartEco mode 2	<CR>*lampm=seco2#<CR>	NO
	Write	SmartEco mode 3	<CR>*lampm=seco3#<CR>	NO
	Write	Dimming mode	<CR>*lampm=dimming#<CR>	YES
	Write	Custom mode	<CR>*lampm=custom#<CR>	YES
	Write	Light level for custom mode	<CR>*lampcustom=value#<CR>	YES
	Read	Light level status for custom mode	<CR>*lampcustom=?#<CR>	YES
	Read	Lamp Mode Status	<CR>*lampm=?#<CR>	YES
Miscellaneous	Read	Model Name	<CR>*modelname=?#<CR>	YES
	Read	System F/W Version	<CR>*sysfwversion=?#<CR>	YES
	Read	Scaler F/W Version	<CR>*scalerfwversion=?#<CR>	NO
	Read	Format F/W version	<CR>*formatfwversion=?#<CR>	NO
	Read	Lan F/W Version	<CR>*lanfwversion=?#<CR>	YES
	Read	MCU F/W Version	<CR>*mcfwversion=?#<CR>	YES
	Read	Ballast F/W Version	<CR>*ballastfwversion=?#<CR>	NO
	Write	Blank On	<CR>*blank=on#<CR>	YES
	Write	Blank Off	<CR>*blank=off#<CR>	YES
	Read	Blank Status	<CR>*blank=?#<CR>	YES
	Write	Freeze On	<CR>*freeze=on#<CR>	YES
	Write	Freeze Off	<CR>*freeze=off#<CR>	YES
	Read	Freeze Status	<CR>*freeze=?#<CR>	YES

	Write	Menu On	<CR>*menu=on#<CR>	YES
	Write	Menu Off	<CR>*menu=off#<CR>	YES
	Read	Menu Status	<CR>*menu=?#<CR>	YES
	Write	Up	<CR>*up#<CR>	YES
	Write	Down	<CR>*down#<CR>	YES
	Write	Right	<CR>*right#<CR>	YES
	Write	Left	<CR>*left#<CR>	YES
	Write	Enter	<CR>*enter#<CR>	YES
	Write	Back	<CR>*back#<CR>	YES
	Write	Source Menu On	<CR>*sourmenu=on#<CR>	YES
	Write	Source Menu Off	<CR>*sourmenu=off#<CR>	YES
	Read	Source Menu Status	<CR>*sourmenu=?#<CR>	YES
	Write	3D Sync Off	<CR>*3d=off#<CR>	YES
	Write	3D Auto	<CR>*3d=auto#<CR>	YES
	Write	3D Sync Top Bottom	<CR>*3d=tb#<CR>	YES
	Write	3D Sync Frame Sequential	<CR>*3d=fs#<CR>	YES
		Write	3D Frame packing	<CR>*3d=fp#<CR>
Write		3D Side by side	<CR>*3d=sbs#<CR>	YES
Write		3D inverter disable	<CR>*3d=da#<CR>	YES
Write		3D inverter	<CR>*3d=iv#<CR>	YES
Write		2D to 3D	<CR>*3d=2d3d#<CR>	NO
Write		3D nVIDIA	<CR>*3d=nvidia#<CR>	NO
Read		3D Sync Status	<CR>*3d=?#<CR>	YES
Write		Remote Receiver On	<CR>*rr=on#<CR>	NO
Write		Remote Receiver Off	<CR>*rr=off#<CR>	NO
Write		Remote Receiver-front+rear	<CR>*rr=fr#<CR>	NO
Write		Remote Receiver-front	<CR>*rr=f#<CR>	YES
Write		Remote Receiver-rear	<CR>*rr=r#<CR>	NO
Write		Remote Receiver-top	<CR>*rr=t#<CR>	YES
Write		Remote Receiver-top+front	<CR>*rr=tf#<CR>	YES
Write		Remote Receiver-top+rear	<CR>*rr=tr#<CR>	NO
Read		Remote Receiver Status	<CR>*rr=?#<CR>	YES
Write		Instant On-on	<CR>*ins=on#<CR>	NO
Write	Instant On-off	<CR>*ins=off#<CR>	NO	

	Read	Instant On Status	<CR>*ins=?#<CR>	NO
	Write	Lamp Saver Mode-on	<CR>*lpsaver=on#<CR>	NO
	Write	Lamp Saver Mode-off	<CR>*lpsaver=off#<CR>	NO
	Read	Lamp Saver Mode Status	<CR>*lpsaver=?#<CR>	NO
	Write	Projection Log In Code on	<CR>*prjlogincode=on#<CR>	NO
	Write	Projection Log In Code off	<CR>*prjlogincode=off#<CR>	NO
	Read	Projection Log In Code Status	<CR>*prjlogincode=?#<CR>	NO
	Write	Broadcasting on	<CR>*broadcasting=on#<CR>	NO
	Write	Broadcasting off	<CR>*broadcasting=off#<CR>	NO
	Read	Broadcasting Status	<CR>*broadcasting=?<CR>	NO
	Write	AMX Device Discovery-on	<CR>*amxdd=on#<CR>	YES
	Write	AMX Device Discovery-off	<CR>*amxdd=off#<CR>	YES
	Read	AMX Device Discovery Status	<CR>*amxdd=?#<CR>	YES
	Read	Mac Address	<CR>*macaddr=?#<CR>	YES
	Write	High Altitude mode on	<CR>*Highaltitude=on#<CR>	YES
	Write	High Altitude mode off	<CR>*Highaltitude=off#<CR>	YES
	Read	High Altitude mode status	<CR>*Highaltitude=?#<CR>	YES
Installation	Write	Load Lens memory 1	<CR>*lensload=m1#<CR>	NO
	Write	Load Lens memory 2	<CR>*lensload=m2#<CR>	NO
	Write	Load Lens memory 3	<CR>*lensload=m3#<CR>	NO
	Write	Load Lens memory 4	<CR>*lensload=m4#<CR>	NO
	Write	Load Lens memory 5	<CR>*lensload=m5#<CR>	NO
	Write	Load Lens memory 6	<CR>*lensload=m6#<CR>	NO
	Write	Load Lens memory 7	<CR>*lensload=m7#<CR>	NO
	Write	Load Lens memory 8	<CR>*lensload=m8#<CR>	NO
	Write	Load Lens memory 9	<CR>*lensload=m9#<CR>	NO
	Write	Load Lens memory 10	<CR>*lensload=m10#<CR>	NO
	Read	Read Lens memory status	<CR>*lensload=?#<CR>	NO
	Write	save Lens memory 1	<CR>*lenssave=m1#<CR>	NO

	Write	save Lens memory 2	<CR>*lenssave=m2#<CR>	NO
	Write	save Lens memory 3	<CR>*lenssave=m3#<CR>	NO
	Write	save Lens memory 4	<CR>*lenssave=m4#<CR>	NO
	Write	save Lens memory 5	<CR>*lenssave=m5#<CR>	NO
	Write	save Lens memory 6	<CR>*lenssave=m6#<CR>	NO
	Write	save Lens memory 7	<CR>*lenssave=m7#<CR>	NO
	Write	save Lens memory 8	<CR>*lenssave=m8#<CR>	NO
	Write	save Lens memory 9	<CR>*lenssave=m9#<CR>	NO
	Write	save Lens memory 10	<CR>*lenssave=m10#<CR>	NO
	Write	Reset Lens to center	<CR>*lensreset=center#<CR>	NO
Color Calibration (only for service)	Write	Tint +	<CR>*tint=+#<CR>	YES
	Write	Tint -	<CR>*tint=-#<CR>	YES
	Write	Set Tint value	<CR>*tint=value#<CR>	YES
	Read	Get Tint value	<CR>*tint=?#<CR>	YES
	Write	Set BenQ gamma value	<CR>*gamma=value#<CR>	YES
	Read	Gamma value status	<CR>*gamma=?#<CR>	YES
	Write	Set HDR Brightness value	<CR>*hdrbri=value#<CR>	YES
	Read	Get HDR Brightness value	<CR>*hdibri=?#<CR>	YES
	Write	Red Gain +	<CR>*RGain=+#<CR>	YES
	Write	Red Gain -	<CR>*RGain=-#<CR>	YES
	Write	Set Red Gain value	<CR>*RGain=value#<CR>	YES
	Read	Get Red Gain value	<CR>*RGain=?#<CR>	YES
	Write	Green Gain +	<CR>*GGain=+#<CR>	YES
	Write	Green Gain -	<CR>*GGain=-#<CR>	YES
	Write	Set Green Gain value	<CR>*GGain=value#<CR>	YES
	Read	Get Green Gain value	<CR>*GGain=?#<CR>	YES
	Write	Blue Gain +	<CR>*BGain=+#<CR>	YES
	Write	Blue Gain -	<CR>*BGain=-#<CR>	YES
	Write	Set Blue Gain value	<CR>*BGain=value#<CR>	YES
	Read	Get Blue Gain value	<CR>*BGain=?#<CR>	YES
	Write	Red Offset +	<CR>*ROffset=+#<CR>	YES
	Write	Red Offset -	<CR>*ROffset=-#<CR>	YES
	Write	Set Red Offset value	<CR>*ROffset=value#<CR>	YES
	Read	Get Red Offset value	<CR>*ROffset=?#<CR>	YES
Write	Green Offset +	<CR>*GOffset=+#<CR>	YES	
Write	Green Offset -	<CR>*GOffset=-#<CR>	YES	

	Write	Set Green Offset value	<CR>*GOffset=value#<CR>	YES
	Read	Get Green Offset value	<CR>*GOffset=?#<CR>	YES
	Write	Blue Offset +	<CR>*BOffset=+#<CR>	YES
	Write	Blue Offset -	<CR>*BOffset=-#<CR>	YES
	Write	Set Blue Offset value	<CR>*BOffset=value#<CR>	YES
	Read	Get Blue Offset value	<CR>*BOffset=?#<CR>	YES
	Write	Primary Color	<CR>*primcr=value#<CR>	YES
	Read	Primary Color Status	<CR>*primcr=?#<CR>	YES
	Write	Hue +	<CR>*hue=+#<CR>	YES
	Write	Hue -	<CR>*hue=-#<CR>	YES
	Write	Set Hue value	<CR>*hue=value#<CR>	YES
	Read	Get Hue value	<CR>*hue=?#<CR>	YES
	Write	Saturation +	<CR>*saturation =+#<CR>	YES
	Write	Saturation -	<CR>*saturation =-#<CR>	YES
	Write	Set Saturation value	<CR>*saturation =value#<CR>	YES
	Read	Get Saturation value	<CR>*saturation =?#<CR>	YES
	Write	Gain +	<CR>*gain=+#<CR>	YES
	Write	Gain -	<CR>*gain=-#<CR>	YES
	Write	Set Gain value	<CR>*gain=value#<CR>	YES
	Read	Get Gain value	<CR>*gain=?#<CR>	YES
	Write	Color Gamut Auto	<CR>*cgamut=auto#<CR>	NO
	Write	Color Gamut BT.709	<CR>*cgamut=bt.709#<CR>	NO
	Write	Color Gamut BT.2020	<CR>*cgamut=bt.2020#<CR>	NO
	Write	Color Gamut DCI-P3	<CR>*cgamut=dci-p3#<CR>	NO
	Read	Color Gamut Value	<CR>*cgamut=?#<CR>	NO
	Write	Dynamic Iris ON	<CR>*diris=on#<CR>	NO
	Write	Dynamic Iris OFF	<CR>*diris=off#<CR>	NO
	Read	Dynamic Iris status	<CR>*diris=?#<CR>	NO
	Write	Color Calibration Save	<CR>*colorsave#<CR>	NO
	Write	Color Calibration pattern display	<CR>*colorpattern=value#<CR>	NO
Service (Only for service)	Write	Service mode enable for error report	<CR>*error=enable#<CR>	YES
	Read	Error code report	<CR>*error=report#<CR>	YES
	Read	FAN 1 speed	<CR>*fan1=?#<CR>	YES
	Read	FAN 2 speed	<CR>*fan2=?#<CR>	YES
	Read	FAN 3 speed	<CR>*fan3=?#<CR>	YES
	Read	FAN 4 speed	<CR>*fan4=?#<CR>	YES

	Read	FAN 5 speed	<CR>*fan5=?#<CR>	YES
	Read	FAN 6 speed	<CR>*fan6=?#<CR>	YES
	Read	Temperature 1	<CR>*tmp1=?#<CR>	YES
	Read	Temperature 2	<CR>*tmp2=?#<CR>	NO
	Read	Temperature 3	<CR>*tmp3=?#<CR>	NO
	Read	LED indicator	<CR>*led=?#<CR>	YES

BenQ.com

© 2018 BenQ Corporation

All rights reserved. Rights of modification reserved.

Version: 1.01-C