

DF8000

FLAT BENCH

Assembly Manual

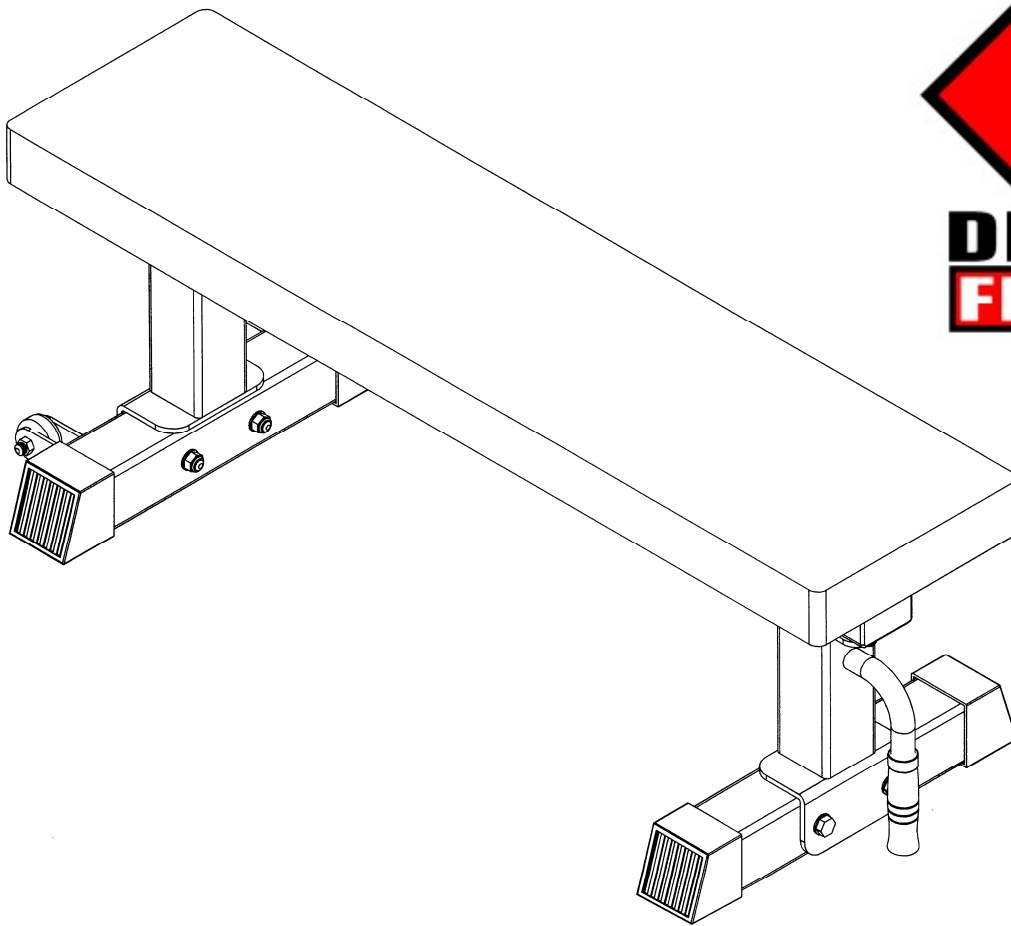

(888) 258-0533

FOR YOUR SAFETY READ ALL INSTRUCTIONS CAREFULLY

*NOTE IF YOU ARE MISSING HARDWARE OR HAVE ANY FIT UP PROBLEMS PLEASE CONTACT DELTECH FITNESS TOLL FREE (888) 258-0533

BOX CONTENTS

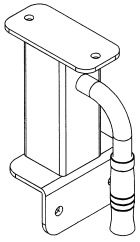

A

**FRONT LEG
QTY 1**

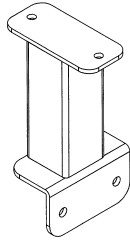

B

**REAR LEG
QTY 1**

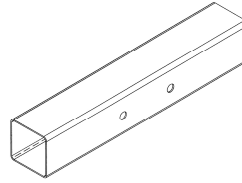

C

**FRONT FOOT
QTY 1**

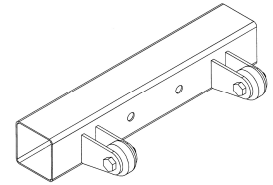

D

**REAR FOOT
QTY 1**

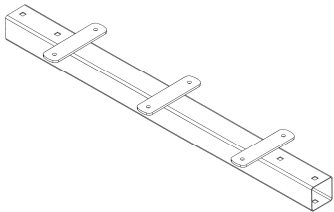

E

**BACKREST
SUPPORT
QTY 1**

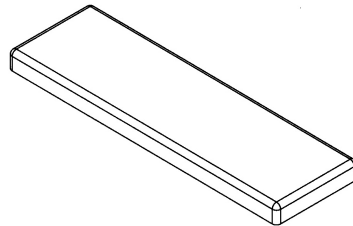

F

**BACKREST
QTY 1**

FOR YOUR SAFETY READ ALL INSTRUCTIONS CAREFULLY

*NOTE IF YOU ARE MISSING HARDWARE OR HAVE ANY FIT UP PROBLEMS PLEASE CONTACT DELTECH FITNESS TOLL FREE (888) 258-0533

HARDWARE

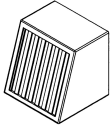

G

**RUBBER SHOE
QTY 4**



H

**SQUARE CAP
QTY 2**

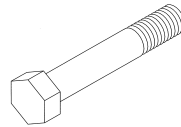

I

**M12 x 100MM BOLT
QTY 4**

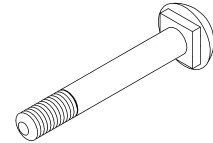

J

**M12 x 100MM
CARRIAGE BOLT
QTY 4**



K

**M10 x 25MM BOLT
QTY 6**



L

**M12 LOCKNUT
QTY 8**



M

**M12 WASHER
QTY 12**



N

**M10 WASHER
QTY 6**

FOR YOUR SAFETY READ ALL INSTRUCTIONS CAREFULLY

*NOTE IF YOU ARE MISSING HARDWARE OR HAVE ANY FIT UP PROBLEMS PLEASE CONTACT DELTECH FITNESS TOLL FREE (888) 258-0533

LEG ASSEMBLY

TOOLS REQUIRED:

METRIC WRENCHES OR SOCKET SET
RUBBER MALLET

Some components may be pre-installed from the factory

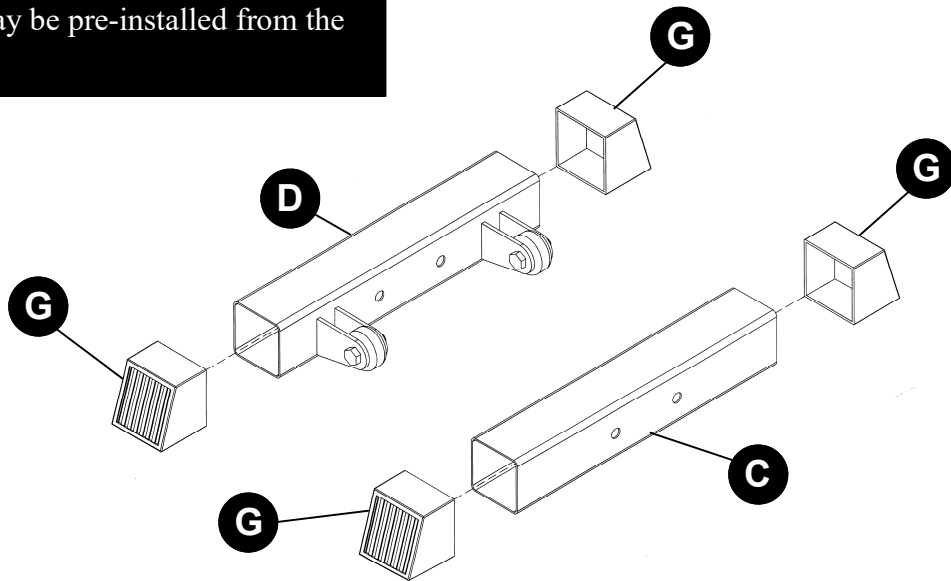

INSTALL RUBBER SHOES (G) TO FRONT FOOT (C) AND REAR FOOT (D). IF RUBBER SHOES ARE DIFFICULT TO INSTALL, USE SOAPY WATER TO MAKE IT EASIER TO SLIDE THEM ON.

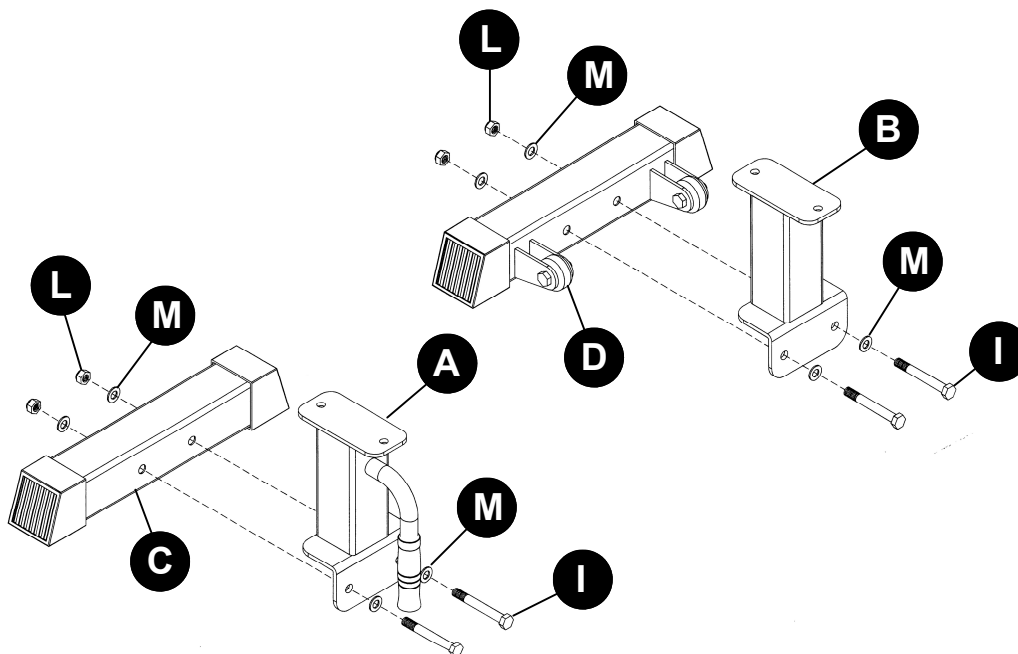

ASSEMBLE FRONT LEG (A) TO FRONT FOOT (C) USING M12 x 75MM BOLTS (I), M12 WASHERS (M), AND M12 LOCKNUTS (L).

ASSEMBLE REAR LEG (B) TO REAR FOOT (D) USING M12 x 75MM BOLTS (I), M12 WASHERS (M), AND M12 LOCKNUTS (L).

DO NOT TIGHTEN NUTS AT THIS TIME.

FRAME ASSEMBLY

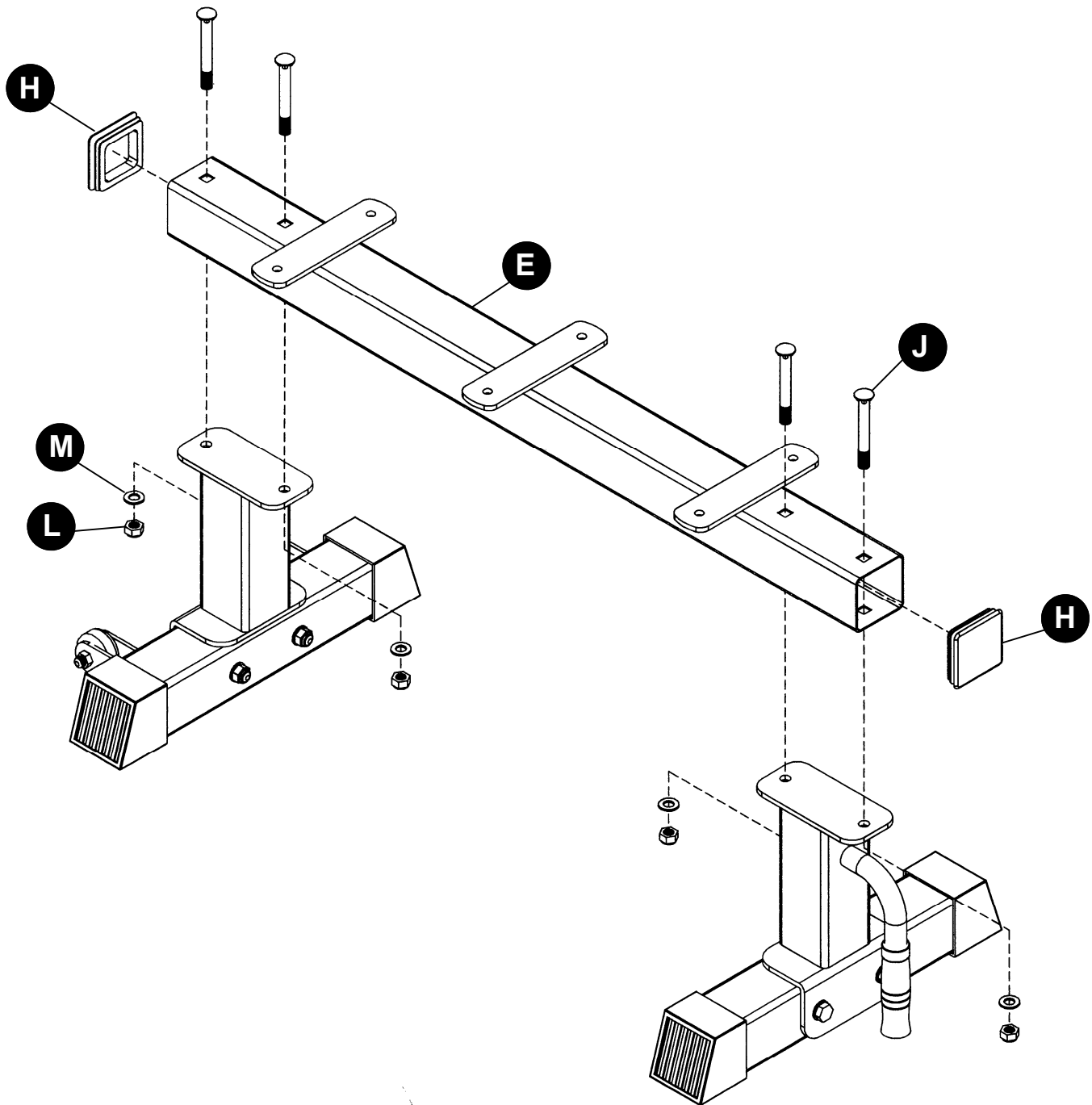

INSTALL SQUARE CAPS **(H)** INTO EACH END OF BACKREST SUPPORT **(E)**. USE A RUBBER Mallet TO SEAT THEM ALL THE WAY IN.

THE CARRIAGE BOLTS HAVE A SQUARE BODY UNDER THE HEAD THAT MUST FIT INTO THE SQUARE HOLE IN THE BACKREST SUPPORT.

ASSEMBLE THE BACKREST SUPPORT **(E)** TO THE FRONT AND REAR LEGS USING M12 x 80MM CARRIAGE BOLTS **(J)**, M12 WASHERS **(M)**, AND M12 LOCKNUTS **(L)**.

TIGHTEN NUTS SECURELY.

BACKREST ASSEMBLY

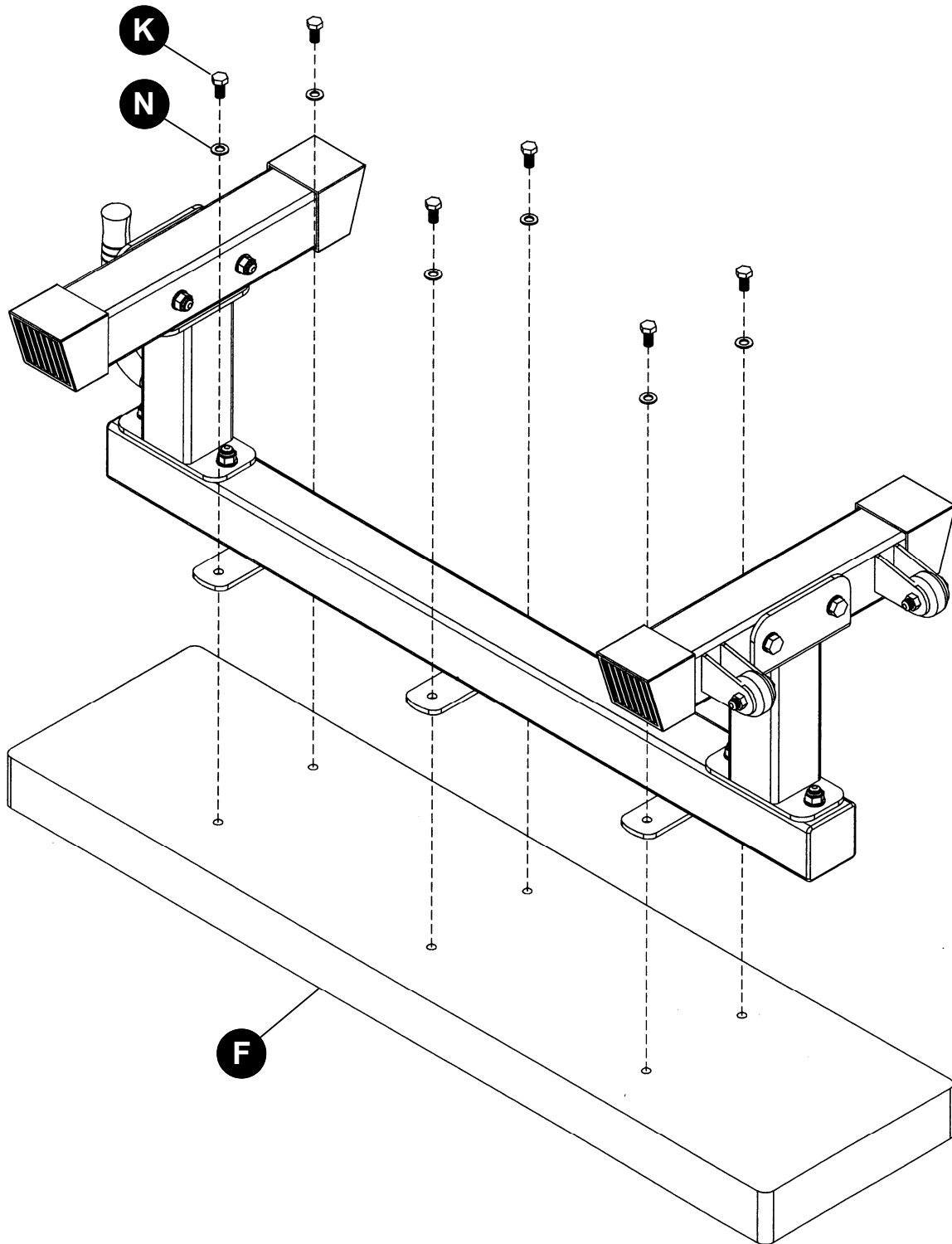

ASSEMBLE THE BACKREST (F) TO THE FRAME ASSEMBLY USING M10 x 25MM BOLTS (K), AND M10 WASHERS (N). MAKE SURE TO INSTALL ALL BOLTS FINGERTIGHT BEFORE TIGHTENING THEM COMPLETELY WITH A WRENCH.

FINAL ASSEMBLY

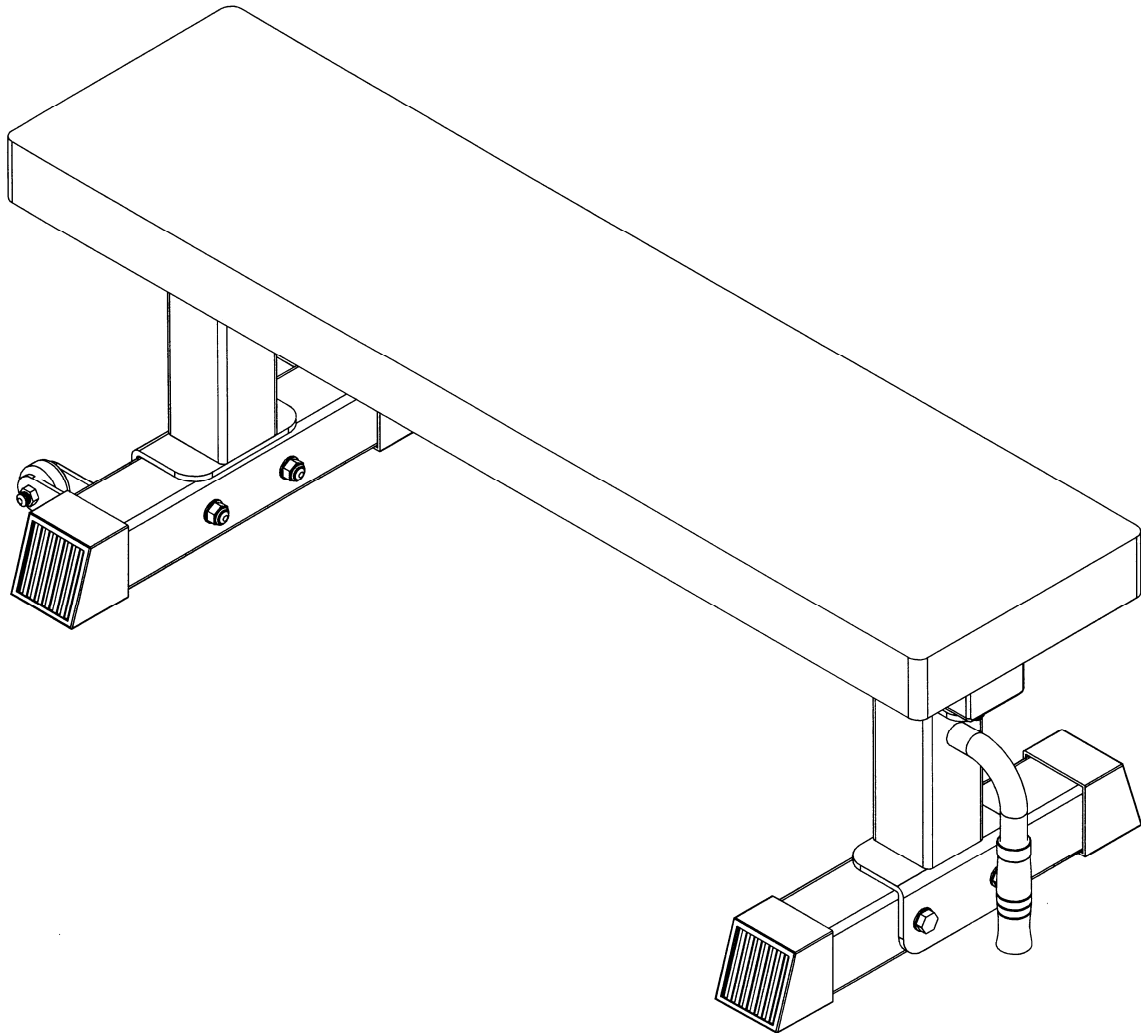

THE FINAL STEP IS TO FIND A FLAT SURFACE TO SET THE BENCH ON. SIT ON THE BENCH TO MAKE SURE ALL FOUR SHOES ARE EVENLY TOUCHING THE FLOOR. TIGHTEN THE NUTS SECURING THE FEET TO THE LEGS.

SAFETY NOTICE

WARNING: THE USER OF THIS WEIGHT EQUIPMENT ASSUMES THE POSSIBILITY OF INJURY BY EXERCISING ON THIS EQUIPMENT. THE RISK OF INJURY CAN BE REDUCED BY ALWAYS FOLLOWING THESE SIMPLE RULES:

- 1) BEFORE BEGINNING ANY EXERCISE PROGRAM, CONSULT YOUR DOCTOR FOR A COMPLETE PHYSICAL EXAMINATION AND SUGGESTED EXERCISE PROGRAM SPECIFIC FOR YOU.
- 2) STRETCH BEFORE AND AFTER THE EXERCISE PROGRAM. PROPER STRETCHING WILL PREPARE YOUR JOINTS AND MUSCLES FOR EXERCISE AND HELP AVOID INJURIES.
- 3) IF AT ANY TIME YOU SHOULD FEEL FAINT OR DIZZY, NAUSEOUS OR EXPERIENCE ANY OTHER ABNORMAL SYMPTOMS OR DISCOMFORT, DISCONTINUE USE AND CONSULT YOUR DOCTOR.
- 4) DO NOT USE THIS EQUIPMENT WITHOUT QUALIFIED SUPERVISION AND PROPER TRAINING. NEVER WORK OUT ALONE- ALWAYS HAVE A PARTNER.
- 5) SECURELY TIGHTEN ALL BOLTS AND REGULARLY CHECK TO ENSURE ALL BOLTS HAVE NOT LOOSENED.
- 6) WEAR GOOD RUBBER SOLE SHOES ONLY. DO NOT USE BARE FOOTED OR WITH SOCKS ONLY.
- 7) DO NOT WEAR LOOSE CLOTHES SUCH AS ROBES, GOWNS, PANTS, LONG SHIRTS OR JEWELRY WHICH COULD BECOME ENTANGLED IN MOVING PARTS.
- 8) DO NOT STAND OR KNEEL ON SEAT. ALWAYS SIT OR LAY SQUARELY CENTERED.
- 9) KEEP HEAD, LIMBS AND BODY PARTS CLEAR OF MOVING PARTS AND WEIGHT PLATES.
- 10) CHILDREN SHOULD NOT USE EXERCISE EQUIPMENT WITHOUT SUPERVISION BECAUSE OF POSSIBILITY OF INJURY FROM IMPROPER USAGE. THIS EQUIPMENT IS INTENDED FOR HOME USE ONLY.
- 11) REPLACEMENT OR WORN OR DEFECTIVE PARTS MUST BE WITH FACTORY AUTHORIZED PARTS. IF OTHER THAN FACTORY AUTHORIZED PARTS OR ACCESSORIES ARE USED ALL WARRANTIES AND LIABILITIES BECOME VOID.