

DF908

LAT PULLDOWN MACHINE WITH 200 LB WEIGHT STACK

Assembly Manual

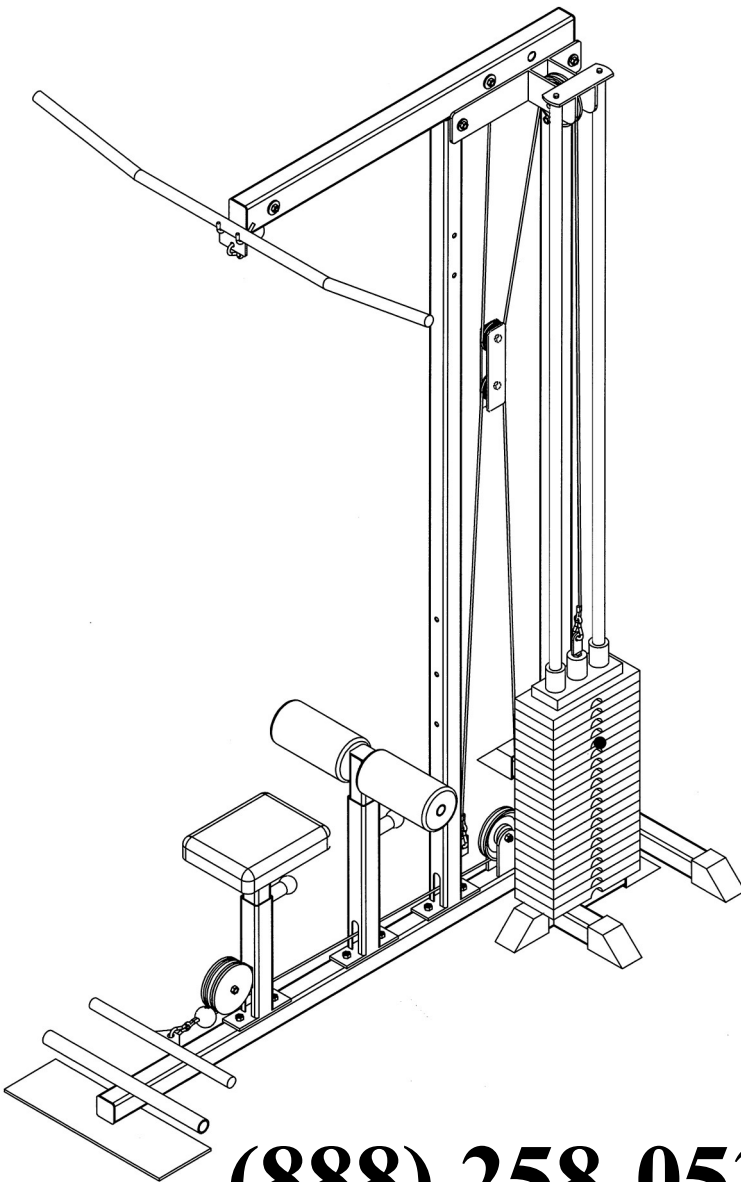

Assembly Video Available

Simply scan the QR code below
on your phone's camera to access



(888) 258-0533

FOR YOUR SAFETY READ ALL INSTRUCTIONS CAREFULLY

*NOTE IF YOU ARE MISSING HARDWARE OR HAVE ANY FIT UP PROBLEMS PLEASE CONTACT DELTECH FITNESS TOLL FREE (888) 258-0533

LAT MACHINE COMPONENTS

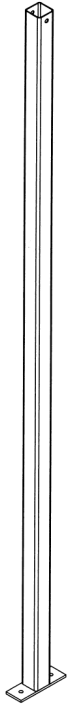

A

**REAR SUPPORT
QTY 1**

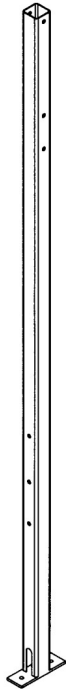

B

**FRONT SUPPORT
QTY 1**

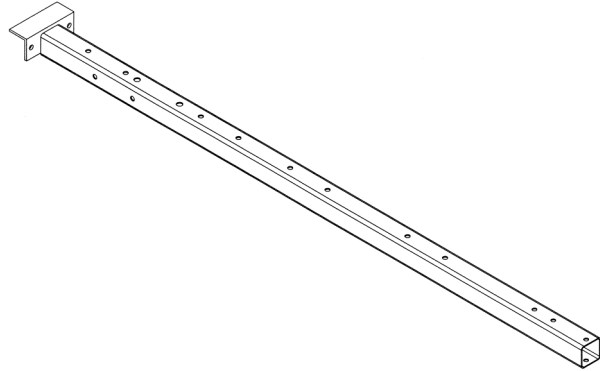

C

**BOTTOM FRAME
QTY 1**

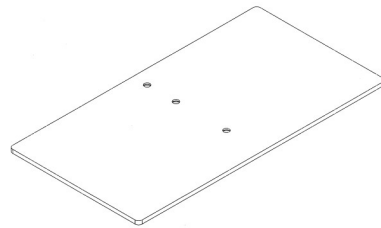

D

**FOOT PLATE
QTY 1**

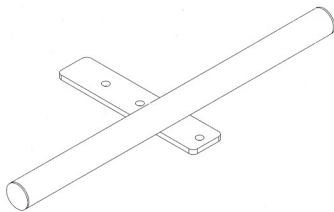

E

**FOOT REST
QTY 1**

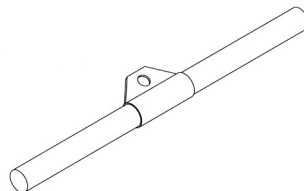

F

**REVOLVING CHROME
ROW BAR
QTY 1**

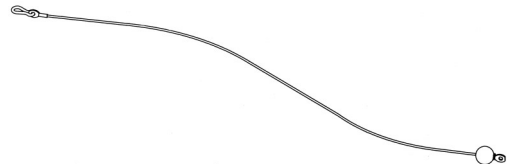

G

**LAT CABLE
QTY 2**

*NOTE IF YOU ARE MISSING HARDWARE OR HAVE ANY FIT UP PROBLEMS PLEASE CONTACT DELTECH FITNESS TOLL FREE (888) 258-0533

LAT MACHINE COMPONENTS

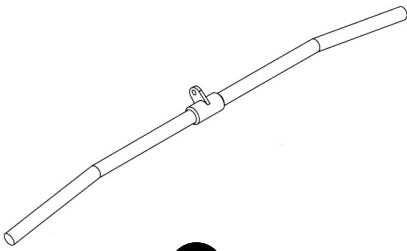

H

LAT BAR
QTY 1

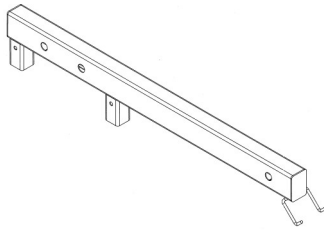

I

UPPER PULLEY
FRAME
QTY 1

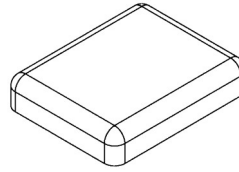

J

SEAT PAD
QTY 1

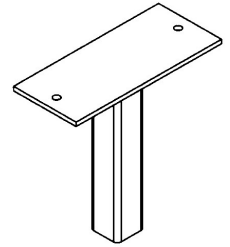

K

SEAT BRACKET
QTY 1

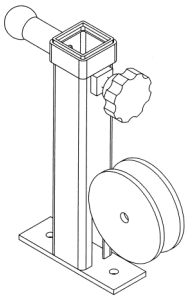

L

SEAT SUPPORT
QTY 1

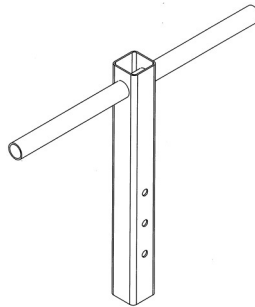

M

HOLD-DOWN
TUBE
QTY 1

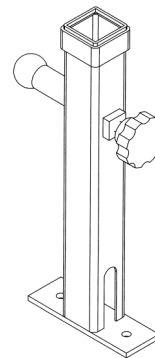

N

HOLD-DOWN SUPPORT
QTY 1

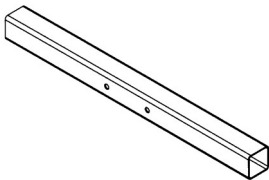

O

REAR CROSSMEMBER
QTY 1

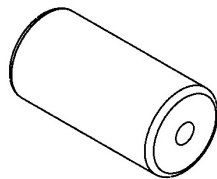

P

ROLLER PAD
QTY 2

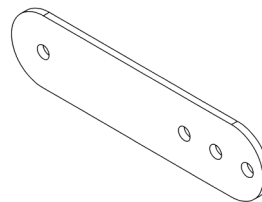

Q

FLANGE
QTY 2

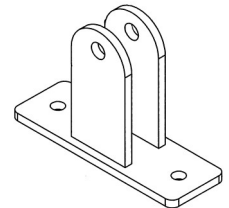

R

BOTTOM PULLEY
FRAME
QTY 1

*NOTE IF YOU ARE MISSING HARDWARE OR HAVE ANY FIT UP PROBLEMS PLEASE CONTACT DELTECH FITNESS TOLL FREE (888) 258-0533

WEIGHT STACK COMPONENTS

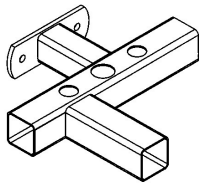

S

**BOTTOM SUPPORT
QTY 1**

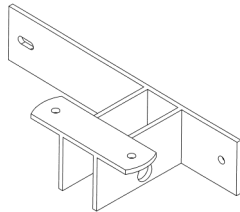

T

**UPPER PULLEY
FRAME
QTY 1**

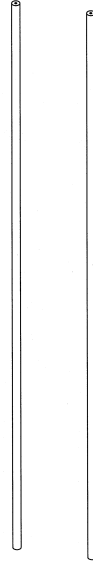

U

**WEIGHT STACK
RODS
QTY 2**

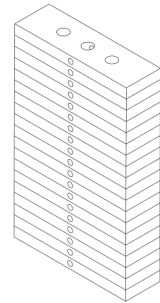

V

**WEIGHT STACK
(19) 10 LB. PLATES
QTY 1**



W

**SELECTOR ROD
QTY 1**

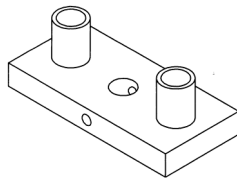

X

**WEIGHT STACK
TOP PLATE
QTY 1**

HARDWARE

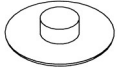

Y

**MUSHROOM CAP
QTY 2**

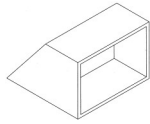

Z

**RUBBER SHOE
QTY 5**



AA

**4-1/2" PULLEY
QTY 3**



BB

**3-1/2" PULLEY
QTY 4**



CC

**PULLEY BUSHING
QTY 6**



DD

**SNAP HOOK
QTY 5**

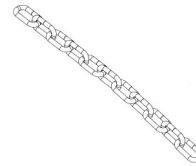

EE

**CHAIN
QTY 2**

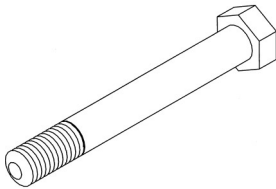

FF

**M12 x 70MM BOLT
QTY 4**

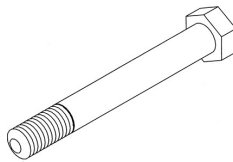

GG

**M10 x 70MM BOLT
QTY 5**

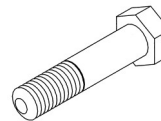

HH

**M10 x 45MM BOLT
QTY 4**

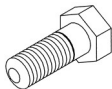

II

**M10 x 20MM BOLT
QTY 4**

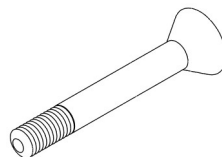

JJ

**M10 x 70MM
FLAT HEAD BOLT
QTY 3**

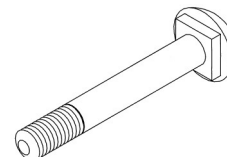

KK

**M10 x 65MM
CARRIAGE BOLT
QTY 10**

(888) 258-0533

FOR YOUR SAFETY READ ALL INSTRUCTIONS CAREFULLY

*NOTE IF YOU ARE MISSING HARDWARE OR HAVE ANY FIT UP PROBLEMS PLEASE CONTACT DELTECH FITNESS TOLL FREE (888) 258-0533

HARDWARE



LL

**M12 WASHER
QTY 8**



MM

**M10 WASHER
QTY 35**



NN

**M12 LOCKNUT
QTY 4**



OO

**M10 LOCKNUT
QTY 22**

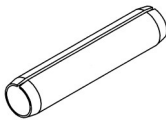

PP

**SPRING PIN
QTY 1**

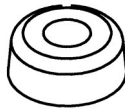

QQ

**RUBBER DOUGHNUTS
QTY 2**

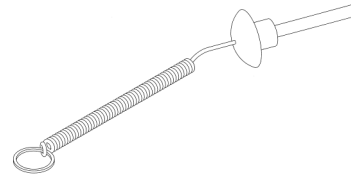

RR

**WEIGHT STACK
ADJUSTMENT PIN
QTY 1**

TOOLS REQUIRED:

METRIC WRENCHES OR SOCKET SET

Some components may be pre-installed from the factory

(NOTE: THE NUTS USED ON THIS BENCH ARE LOCK NUTS, THIS MEANS YOU MUST TIGHTEN THEM DOWN

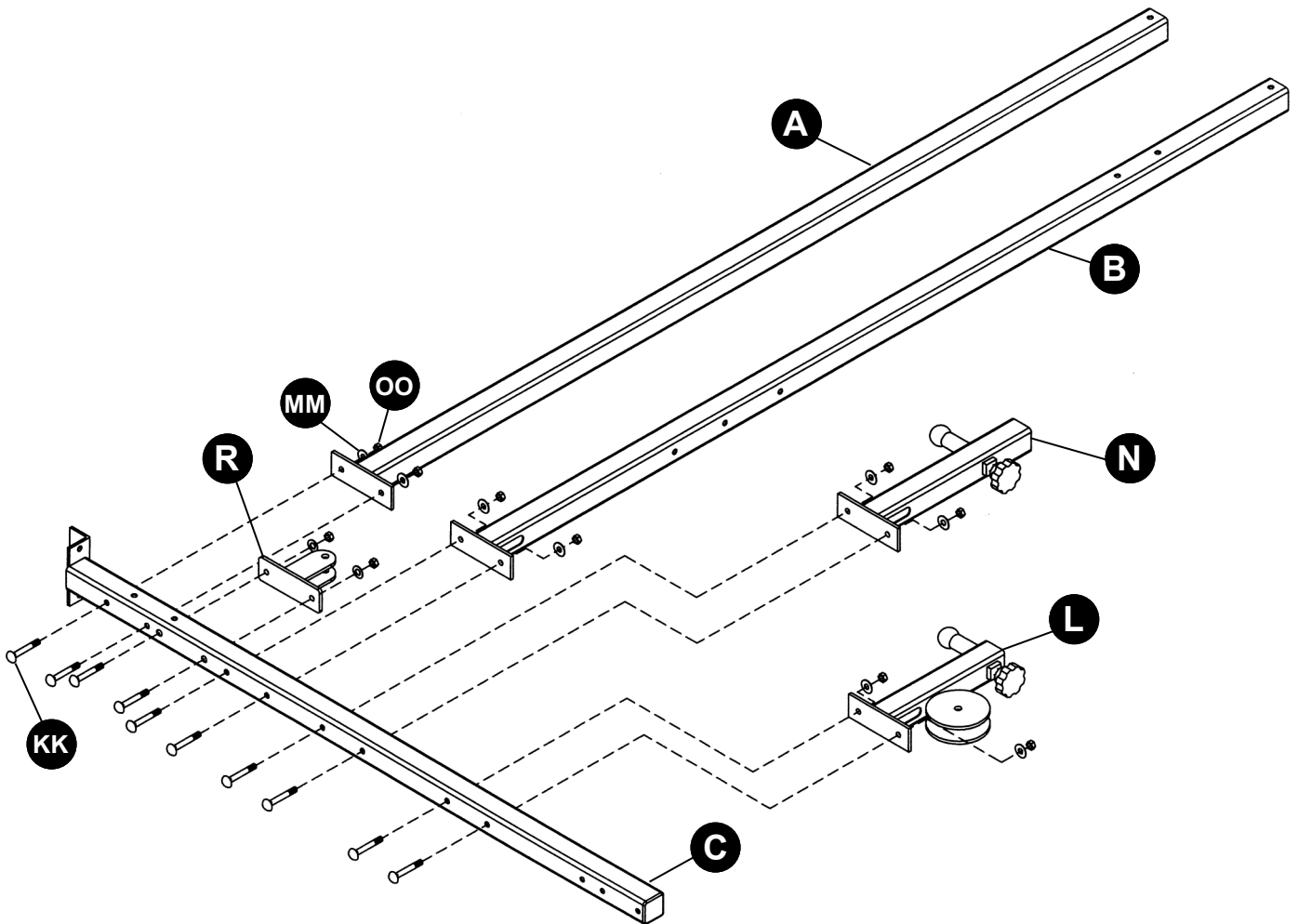

LAY BOTTOM FRAME (C) ON ITS SIDE ON LEVEL FLOOR. INSTALL FRONT & REAR SUPPORTS (A), (B) TO BOTTOM FRAME (C) USING THE M10 x 65MM CARRIAGE BOLTS (KK), M10 WASHERS (MM), AND M10 LOCKNUTS (OO).

INSTALL BOTTOM PULLEY FRAME (R), HOLD-DOWN SUPPORT (M), AND SEAT SUPPORT (J) TO BOTTOM FRAME (C) USING THE M10 x 65MM CARRIAGE BOLTS (KK), M10 WASHERS (MM), AND M10 LOCKNUTS (OO).

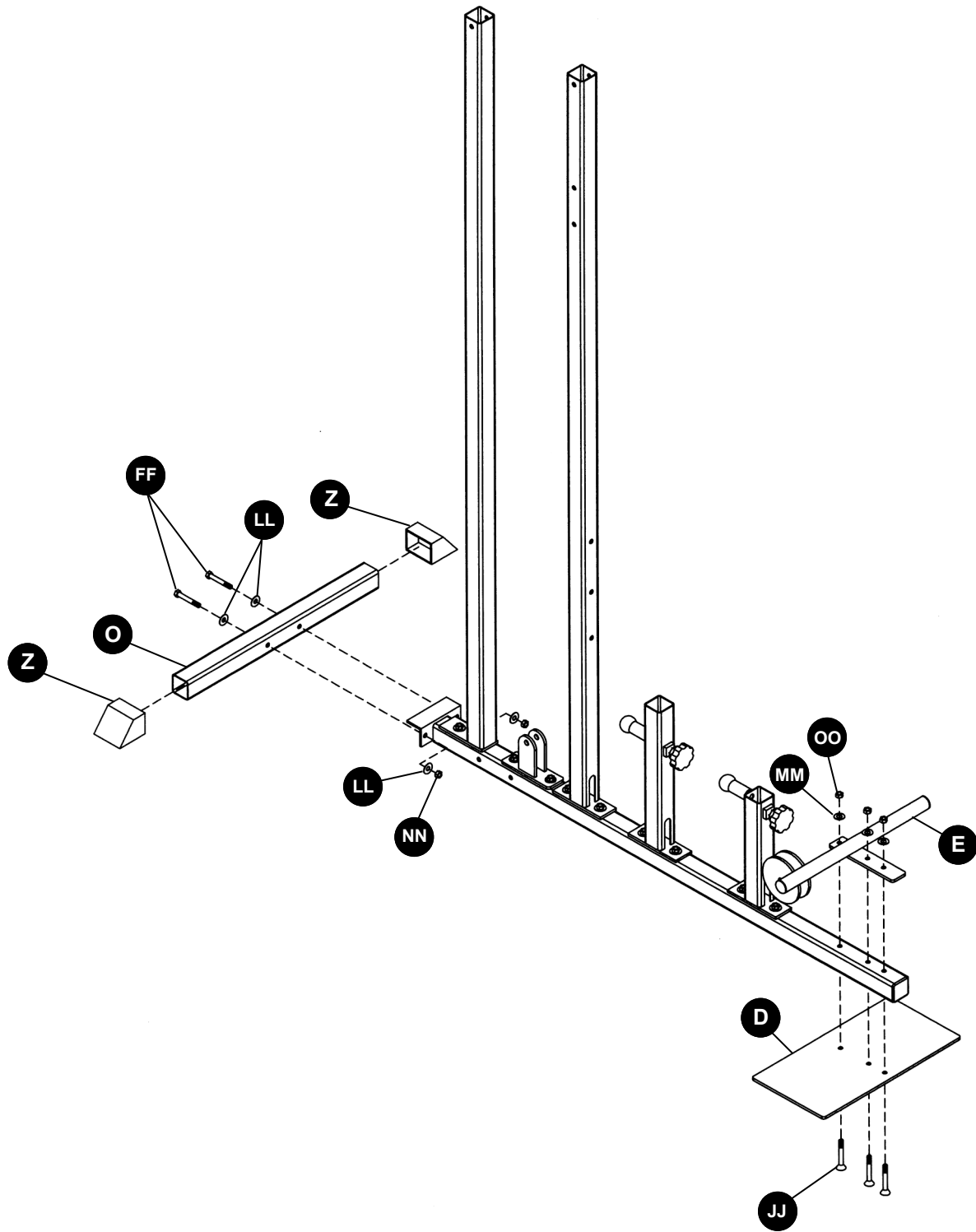

ROTATE THE ASSEMBLY TO THE UPRIGHT POSITION AND SLIDE THE REAR CROSSMEMBER (O) INTO PLACE AND INSTALL TO THE BOTTOM FRAME USING THE M12 x 70MM BOLTS (FF), M12 WASHERS (LL), AND M12 LOCKNUTS (NN). INSTALL THE RUBBER BOOTS (Z) OVER THE ENDS OF THE CROSSMEMBER. ATTACH THE FOOT PLATE (D) AND FOOT REST (E) TO THE BOTTOM FRAME USING M10 x 70 MM FLAT HEAD BOLTS (JJ), M10 WASHERS (MM), AND M10 LOCKNUTS (OO).

SEAT FRAME ASSEMBLY

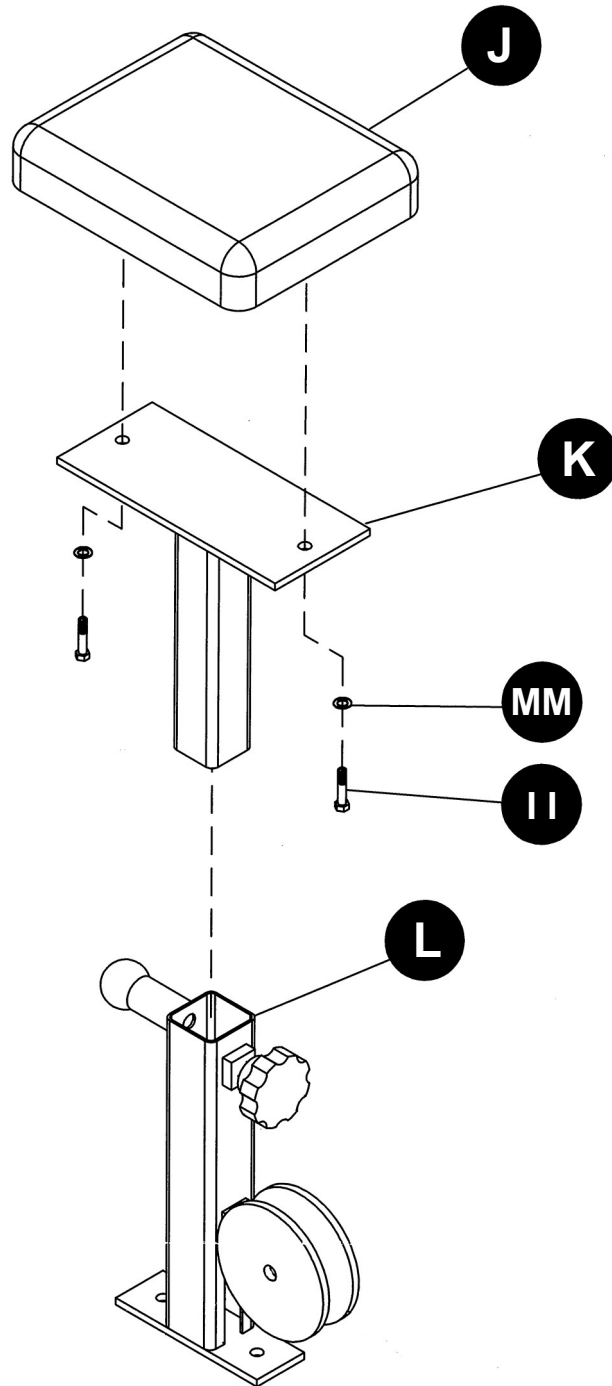

ATTACH THE SEAT PAD (J) TO THE SEAT BRACKET (K) USING THE M10 x 20MM BOLTS (II) AND M10 FLAT WASHERS (MM). THEN SLIDE THE SEAT BRACKET (K) INTO THE SEAT SUPPORT (L).

LEG HOLD DOWN ASSEMBLY

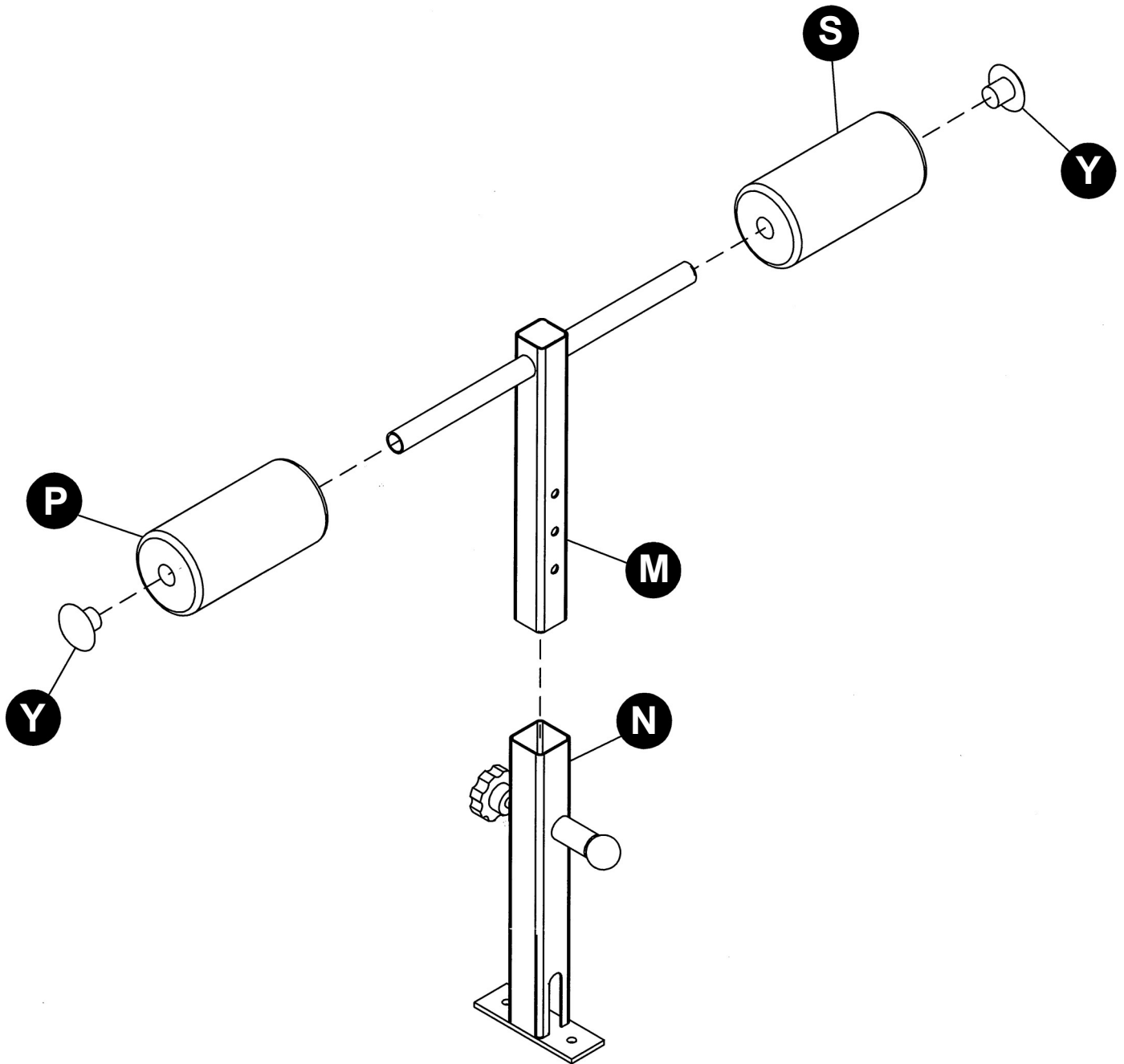

SLIDE THE HOLD-DOWN TUBE (M) INTO THE HOLD-DOWN SUPPORT (N) . LOCK INTO PLACE WITH PULL-PIN.

SLIDE THE ROLLER PADS (P) OVER THE LEG PAD TUBE AND INSERT THE MUSHROOM CAPS (Y). TAP INTO PLACE WITH A RUBBER HAMMER.

BOTTOM PULLEY FRAME ASSEMBLY

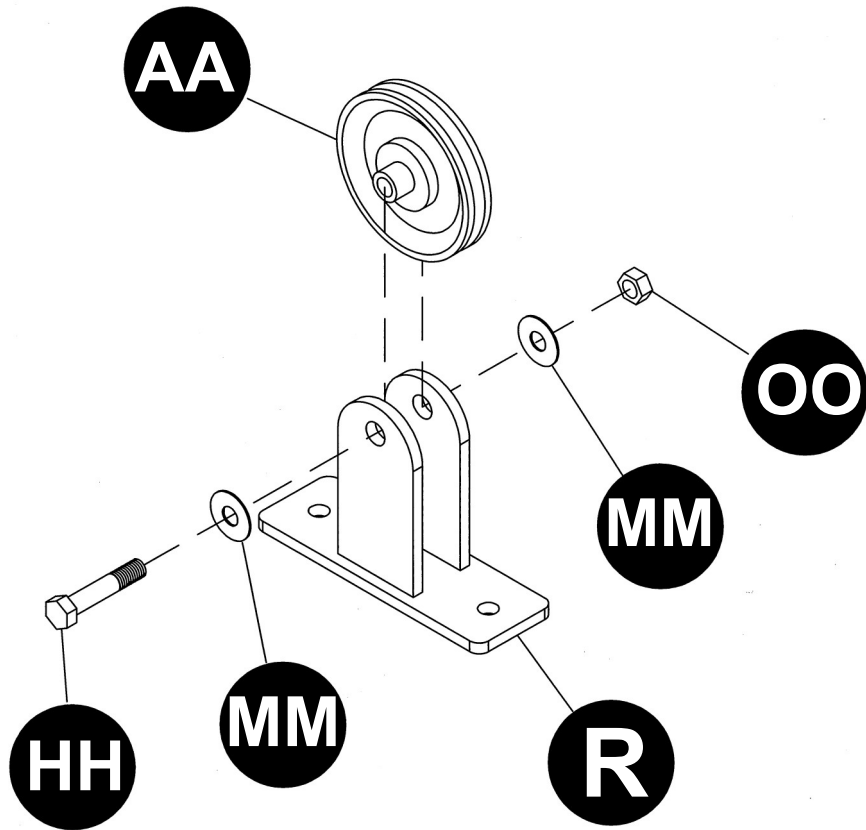

ASSEMBLE THE 4 ½" PULLEY (AA) INTO THE BOTTOM PULLEY FRAME (R) USING THE M10 x 45MM BOLT (HH), M10 WASHERS (MM), AND M10 LOCKNUT (OO).

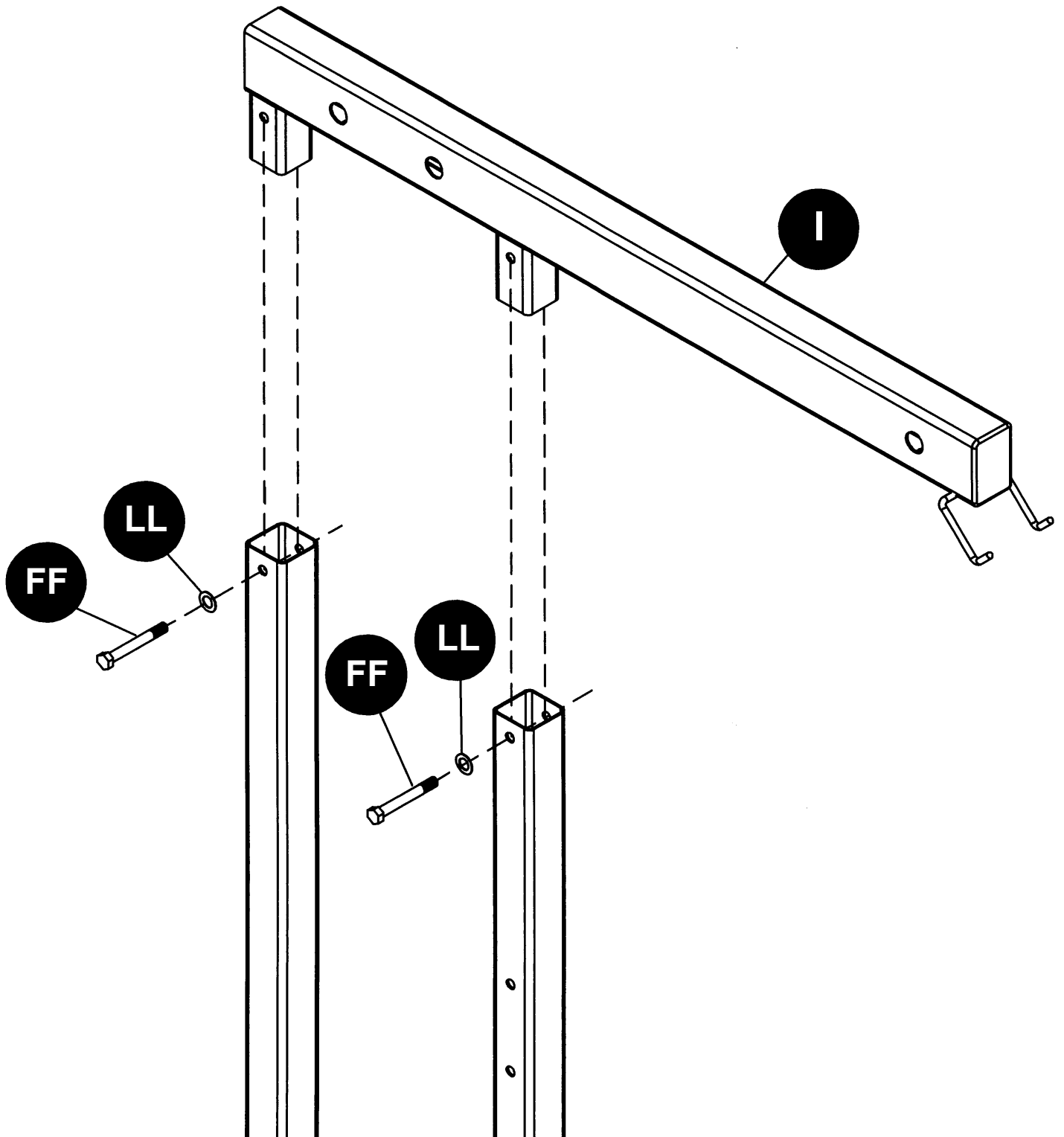

ASSEMBLE THE UPPER PULLEY FRAME (I) ONTO THE FRONT AND REAR SUPPORTS USING THE M12 x 70MM BOLTS(FF), AND M12 WASHERS (LL).

DO NOT INSTALL WASHERS AND LOCKNUTS ON BOLTS AT THIS TIME.

UPPER PULLEY FRAME INSTALLATION

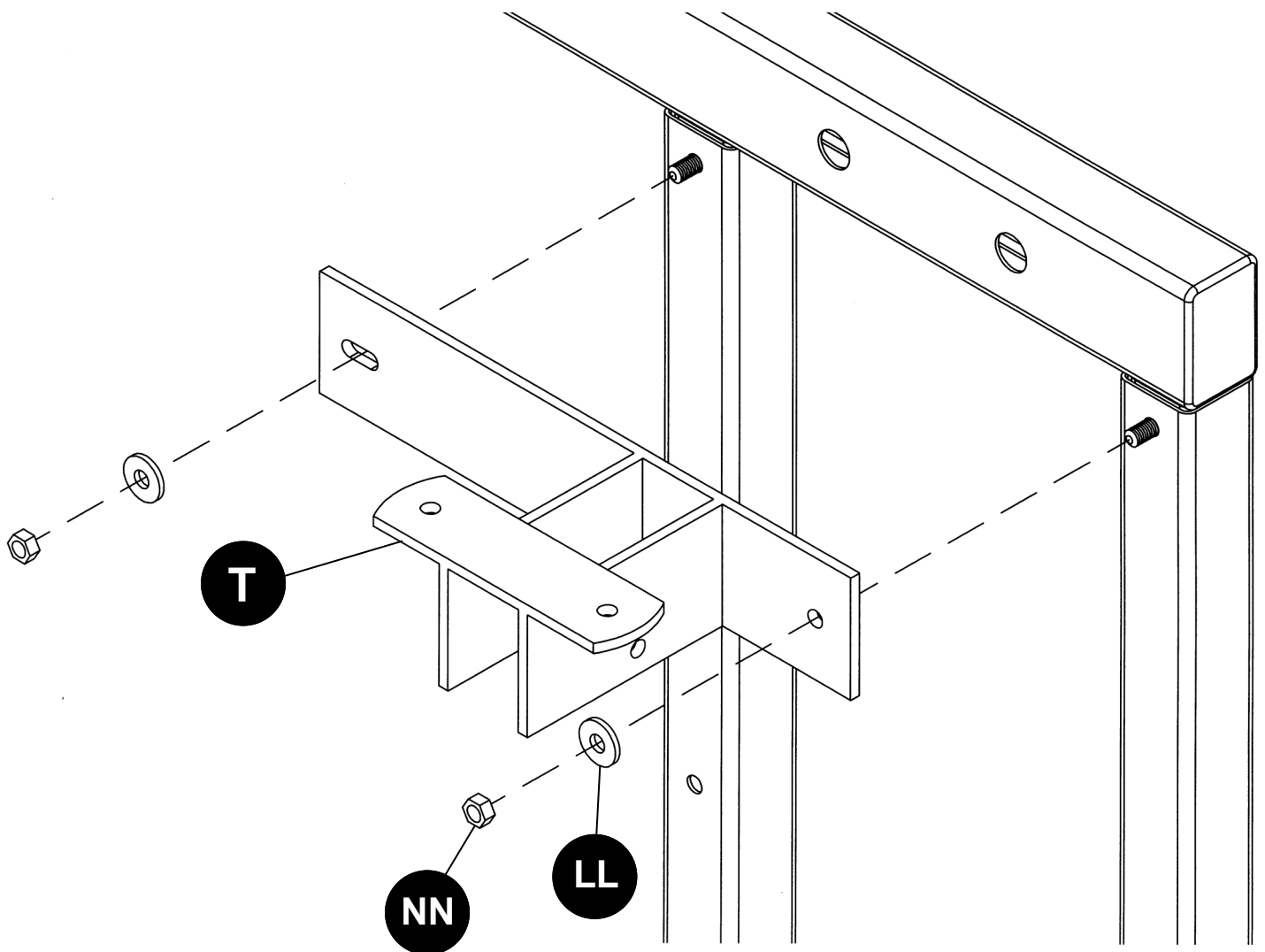

INSTALL THE UPPER PULLEY ASSEMBLY (T) TO THE FRONT AND REAR SUPPORT USING M12 WASHERS (LL), AND M12 LOCKNUTS (NN). DO NOT TIGHTEN AT THIS TIME.

WEIGHT STACK FRAME ASSEMBLY

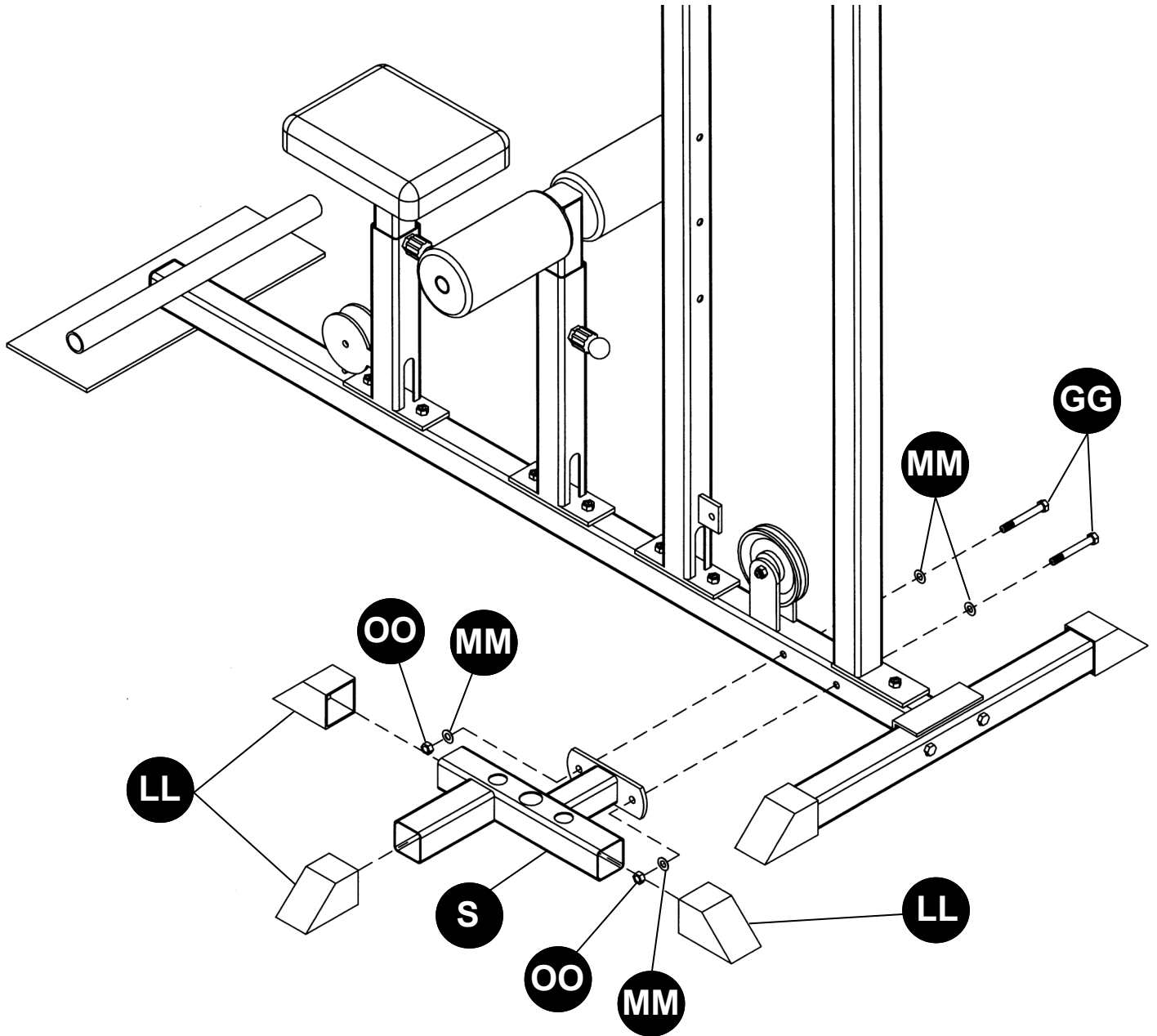

INSTALL THE RUBBER SHOES (LL) ON TO THE BOTTOM SUPPORT(S). ATTACH THE BOTTOM SUPPORT (S) TO THE LAT MACHINE USING THE M10 x 70MM BOLTS (GG) M10 FLAT WASHERS (MM) AND THE M10 LOCK NUTS (OO).

WEIGHT STACK ASSEMBLY

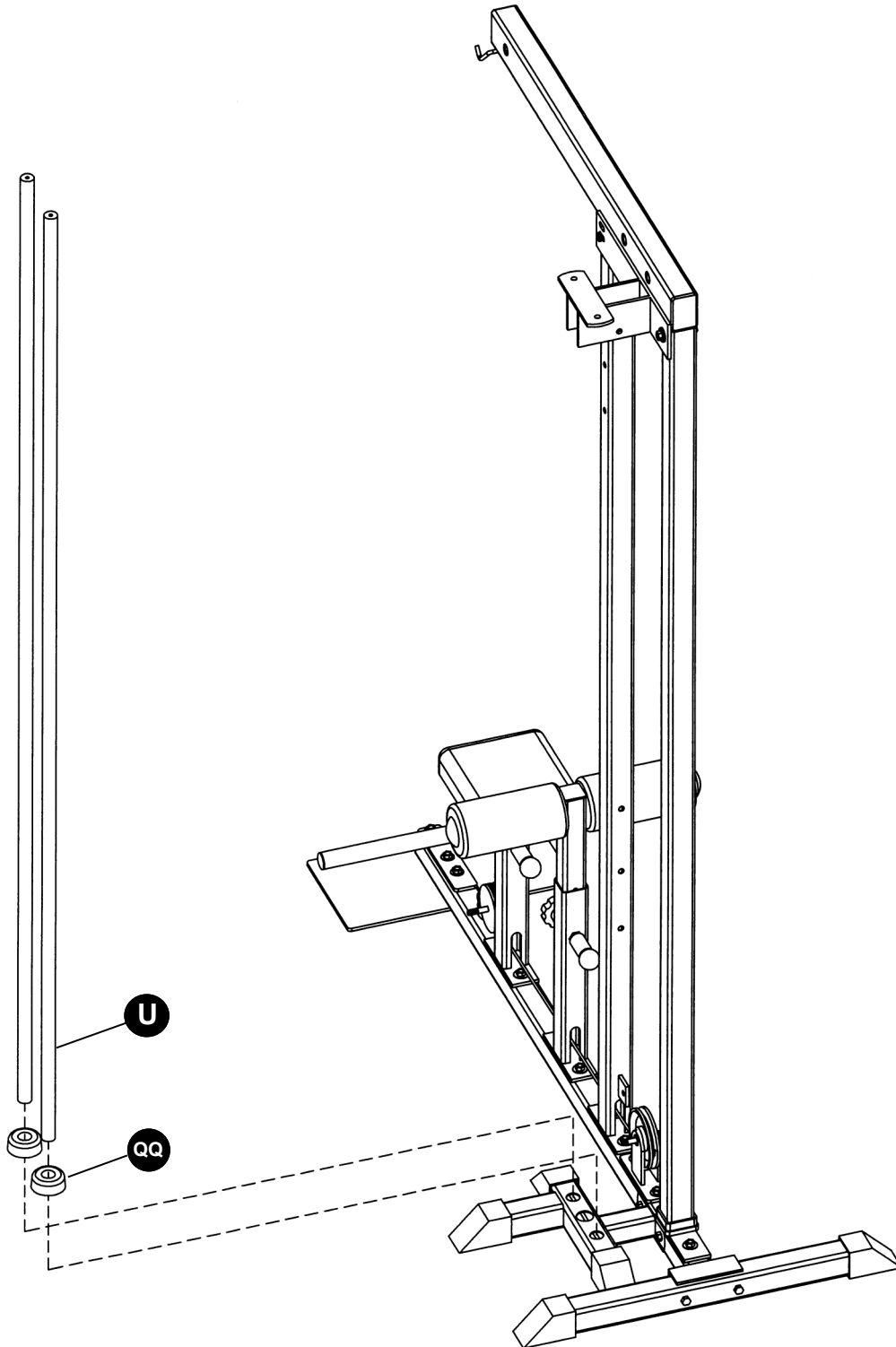

INSTALL THE RUBBER DOUGHNUTS (QQ) ONTO THE BOTTOM OF THE WEIGHT STACK RODS (U) , LEAVING APPROXIMATELY 2" PROTRUDING. INSERT THE WEIGHT STACK RODS INTO THE TWO OUTER HOLES IN THE BOTTOM FRAME.

TOP WEIGHT PLATE ASSEMBLY

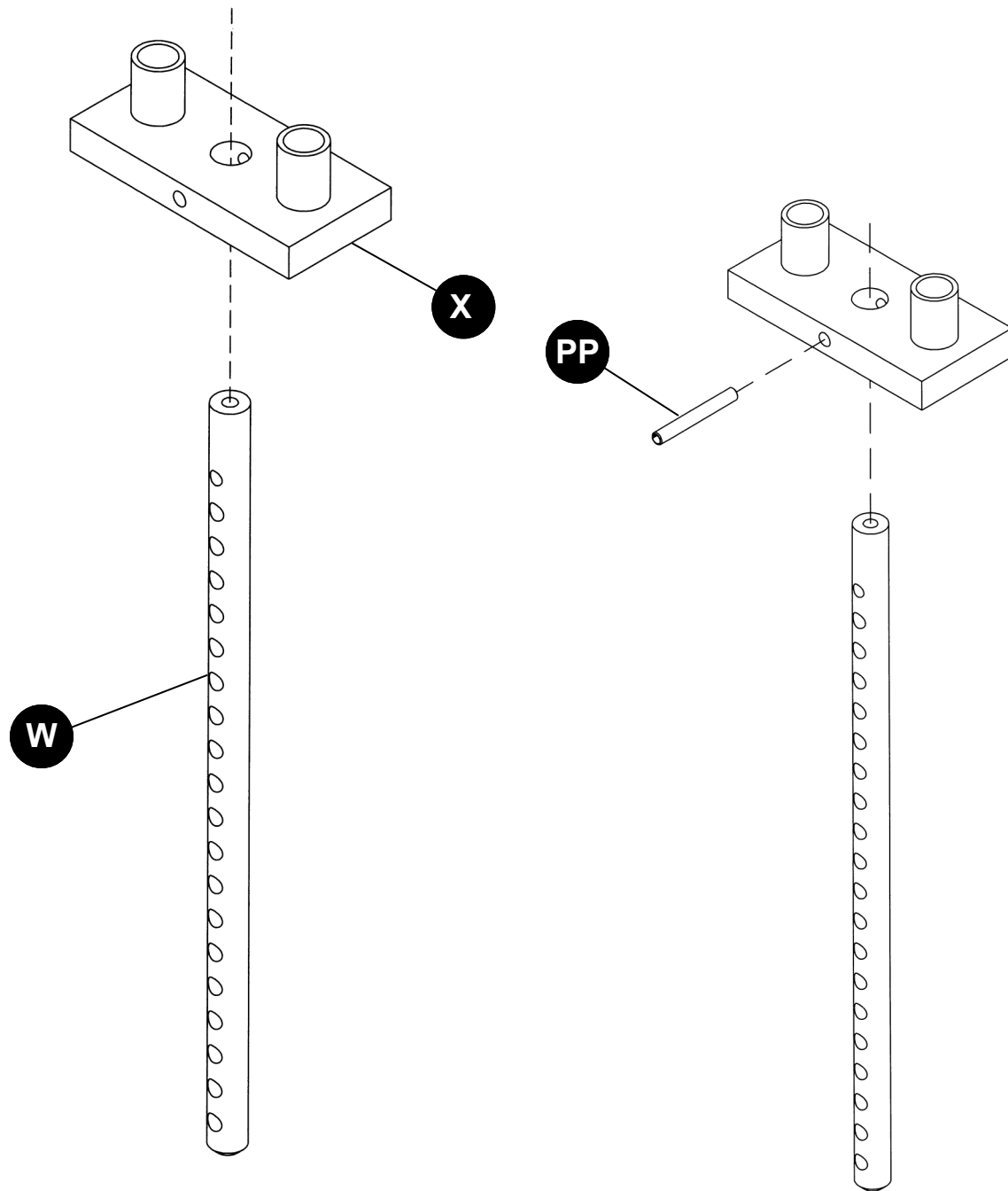

INSERT SELECTOR ROD (**W**) INTO CENTER HOLE OF TOP PLATE (**X**) ALIGNING TOP HOLE OF SELECTOR ROD WITH SPRING PIN HOLE. INSERT SPRING PIN (**PP**) AND TAP WITH HAMMER UNTIL FLUSH WITH SURFACE.

WEIGHT STACK ASSEMBLY

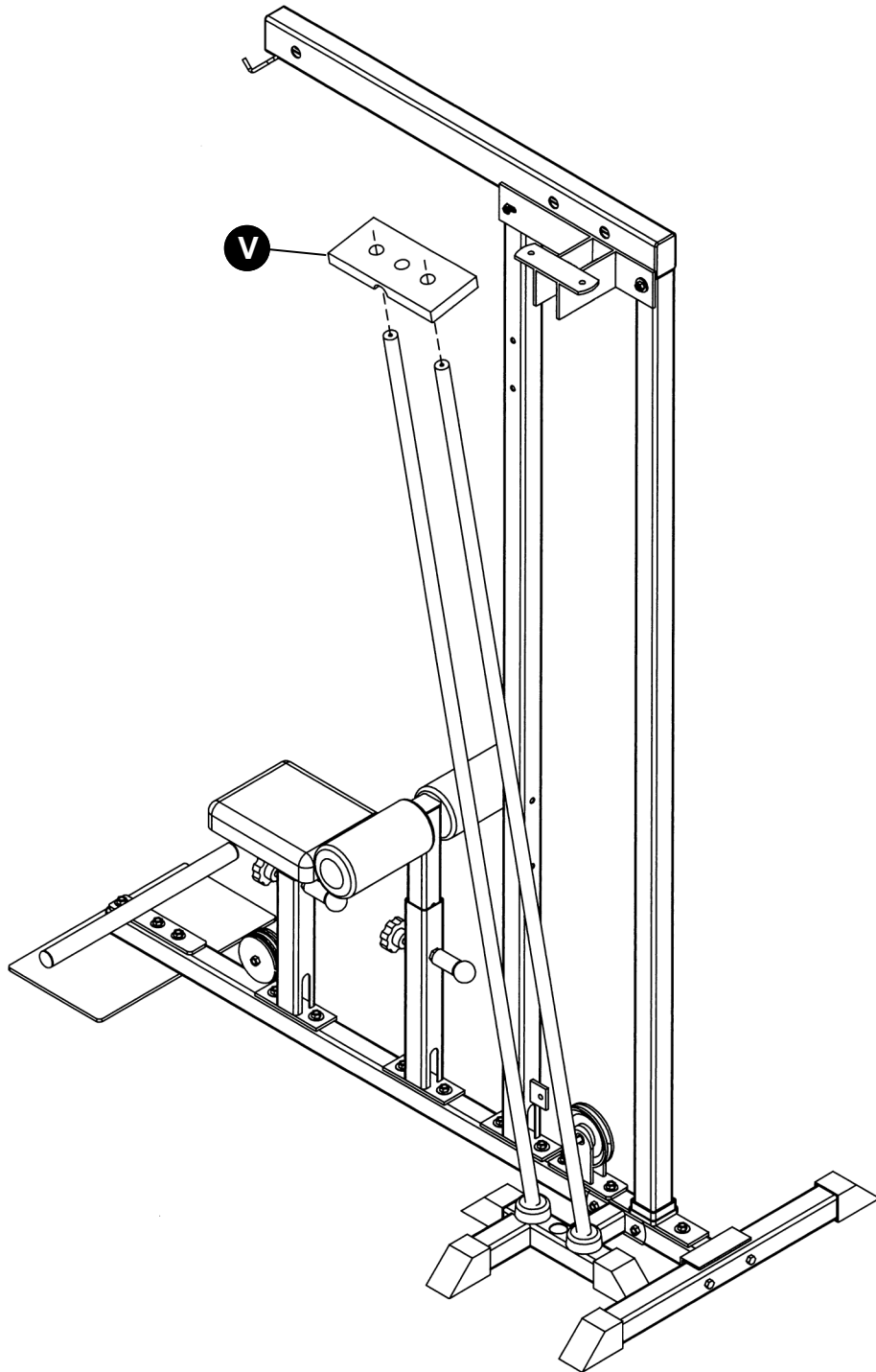

LEAN WEIGHT STACK RODS OUT SLIGHTLY AND BEGIN INSTALLING WEIGHT STACK PLATES (V), USING TWO OUTER HOLES ON EACH WEIGHT STACK PLATE. SLIDE EACH WEIGHT STACK DOWN BEFORE INSTALLING THE NEXT. THERE ARE 19 WEIGHT STACK PLATES.

WEIGHT STACK ASSEMBLY

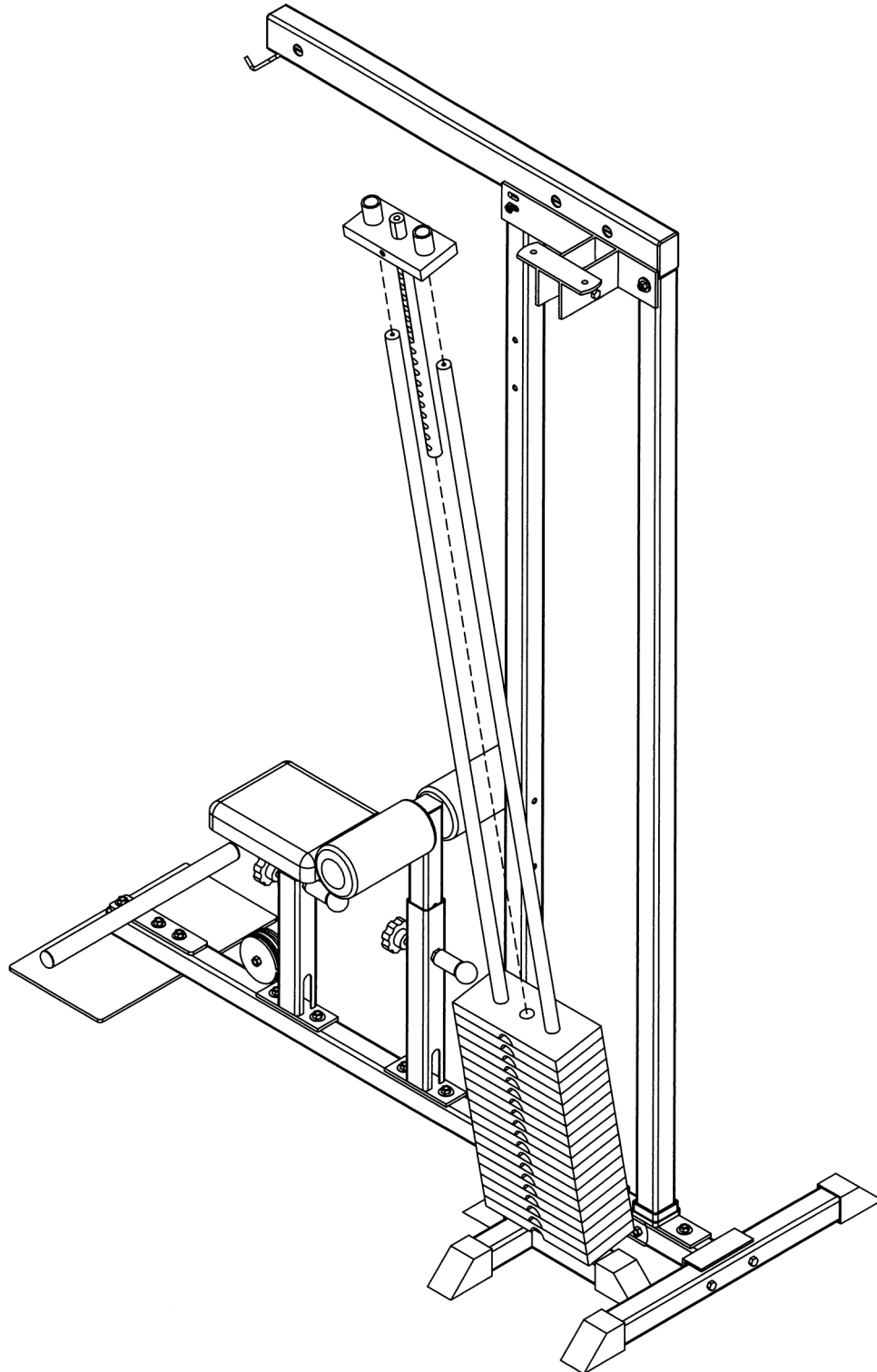

INSTALL TOP WEIGHT PLATE ASSEMBLY USING TWO OUTER HOLES OVER WEIGHT STACK RODS. SLIDE DOWN AND INSERT SELECTOR ROD INTO WEIGHT PLATE STACK.

WEIGHT STACK ASSEMBLY

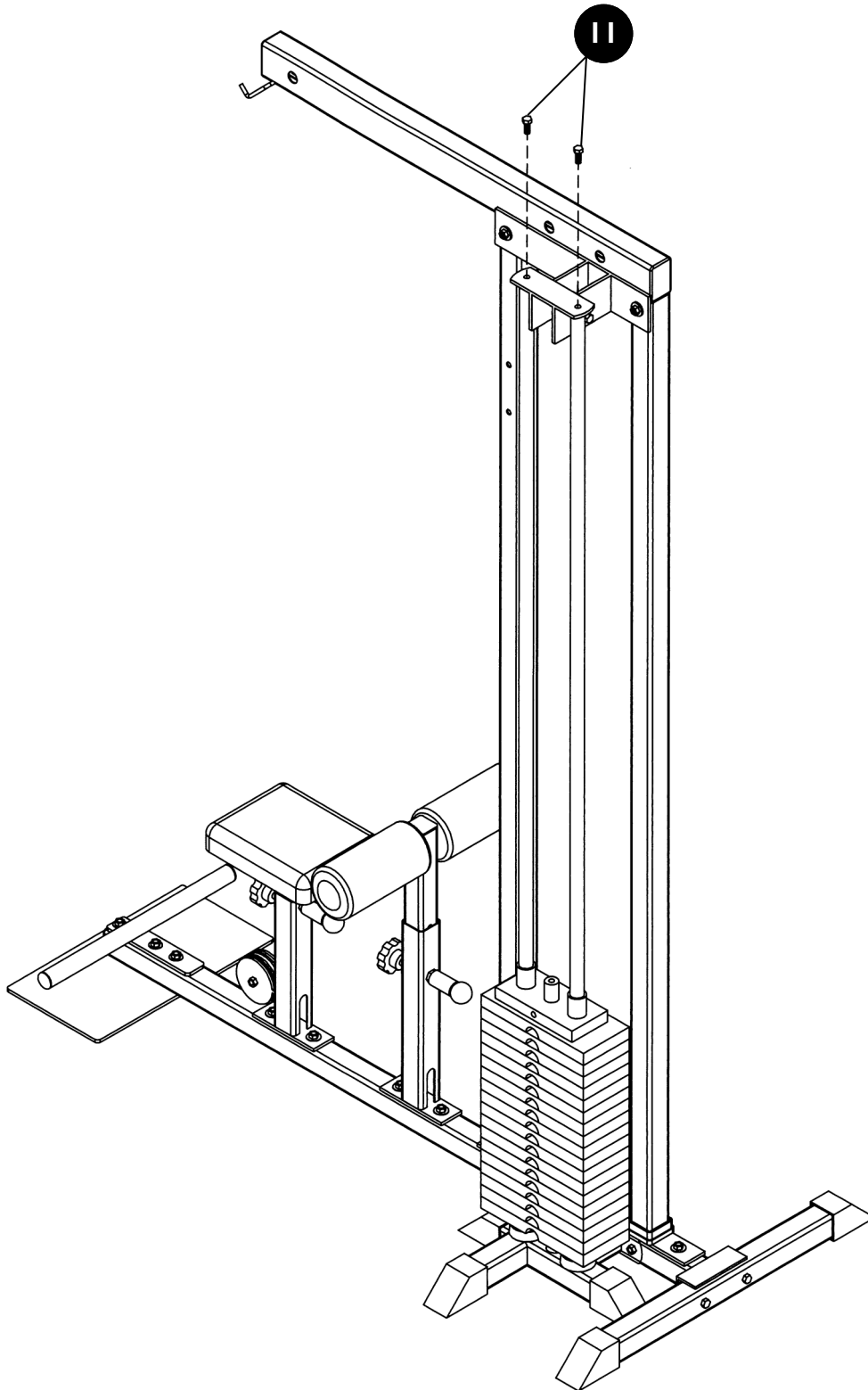

ROTATE WEIGHT STACK RODS UP TOWARDS THE UPPER PULLEY ASSEMBLY. INSTALL M10 x 20MM BOLTS (II) INTO TOP OF WEIGHT STACK RODS.

UPPER CABLE INSTALLATION

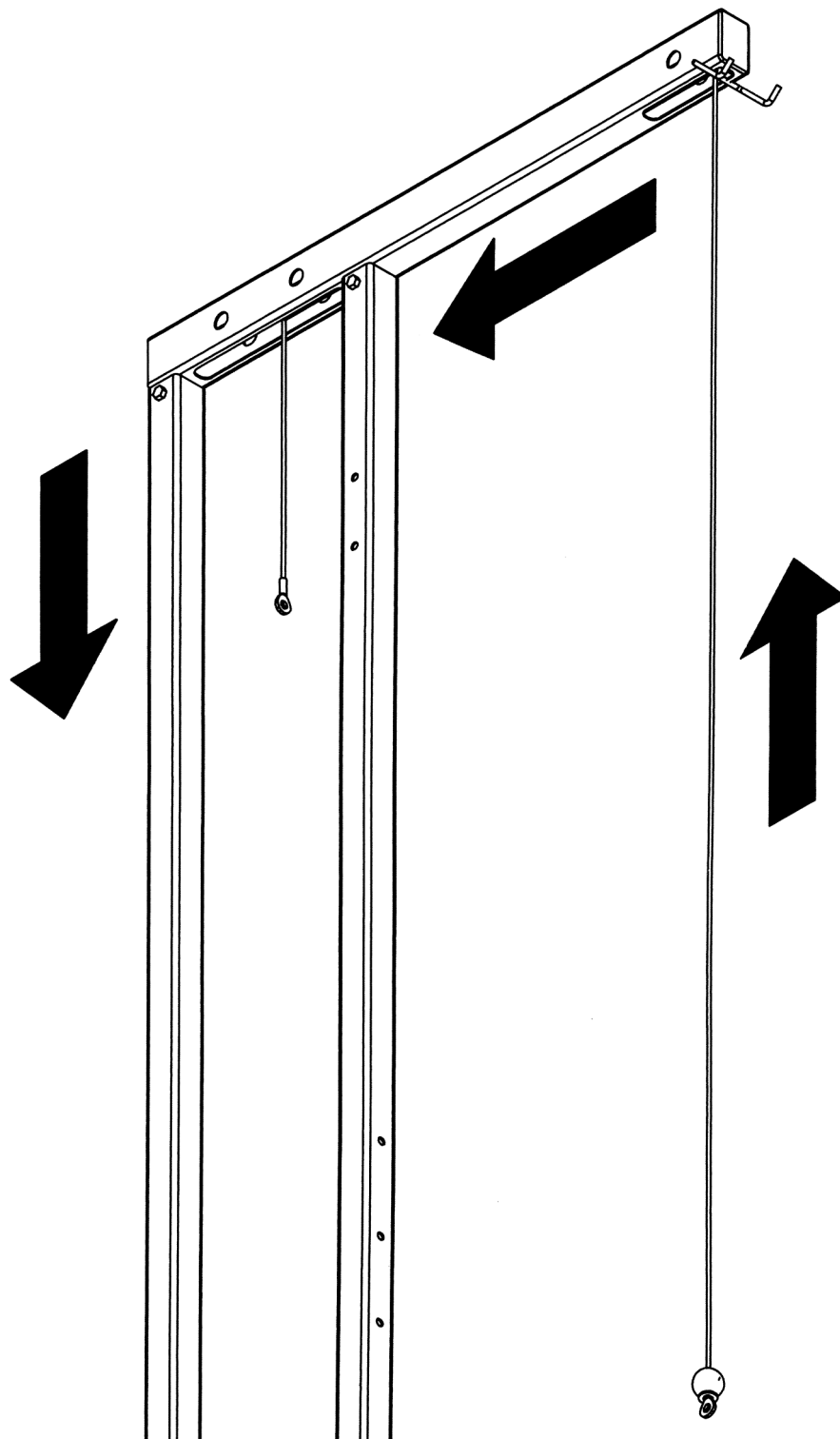

BOTH CABLES ARE THE SAME LENGTH.

STARTING WITH THE CABLE END WITHOUT THE BALL, INSERT CABLE INTO FRONT OPENING OF THE UPPER PULLEY FRAME AND FEED IT TOWARDS THE BACK. PULL CABLE END OUT THROUGH REAR OPENING.

UPPER CABLE INSTALLATION

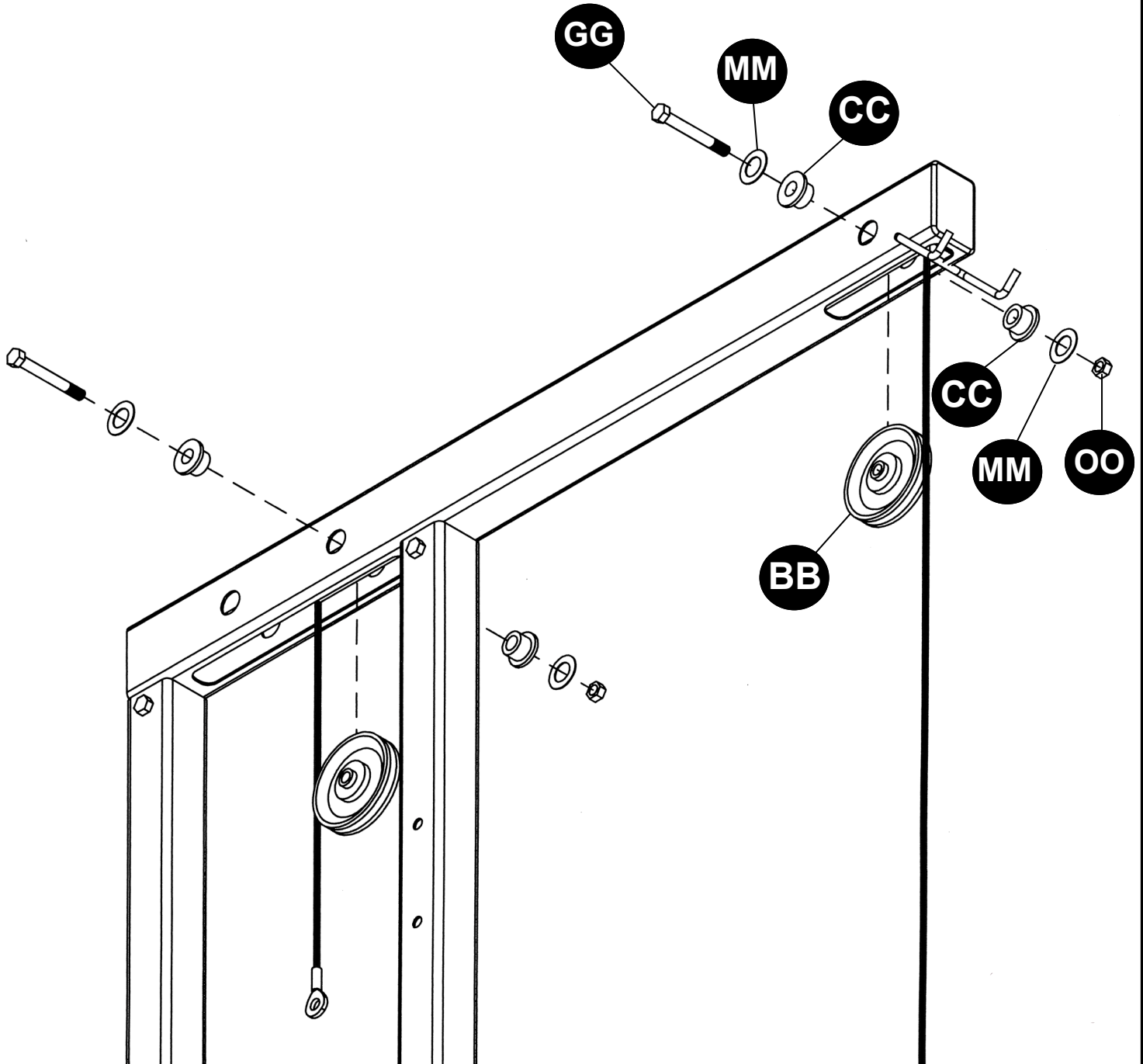

INSERT 3-1/2" PULLEY (**BB**) INTO FRONT OPENING OF UPPER PULLEY FRAME AND INSTALL USING THE M10 x 70MM BOLT (**GG**), PULLEY BUSHINGS (**CC**), AND M10 LOCKNUTS (**OO**). REPEAT FOR MIDDLE PULLEY.

FLOATING PULLEY ASSEMBLY

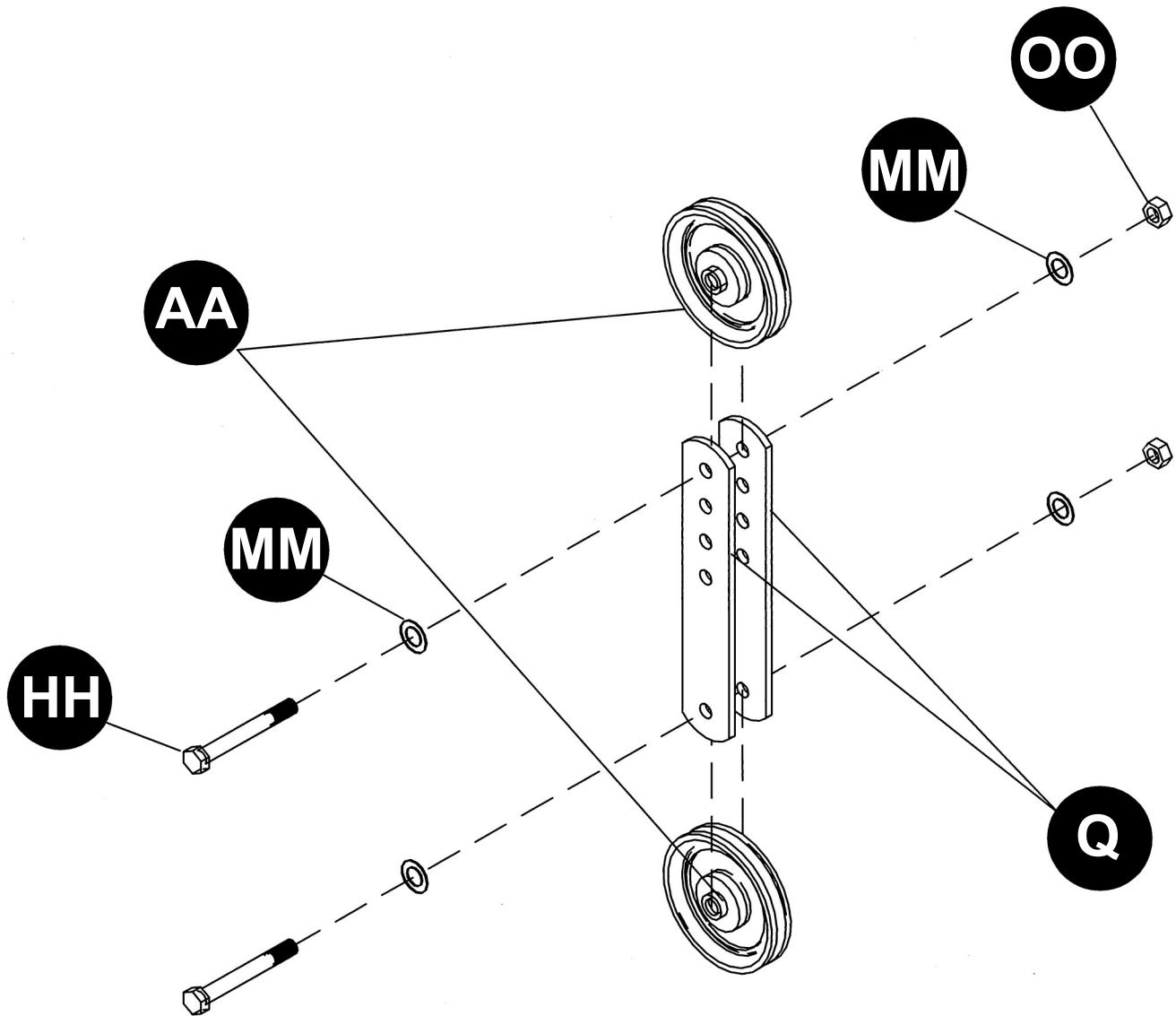

ASSEMBLE THE FLOATING PULLEY ASSEMBLY USING THE 4-1/2" PULLEYS (AA), THE PULLEY FLANGES (Q), THE M10 x 45MM BOLTS (HH), THE M10 FLAT WASHERS (MM), AND THE M10 LOCKNUTS (OO).

UPPER CABLE INSTALLATION

UPPER PULLEY FRAME REMOVED
FOR CLARITY

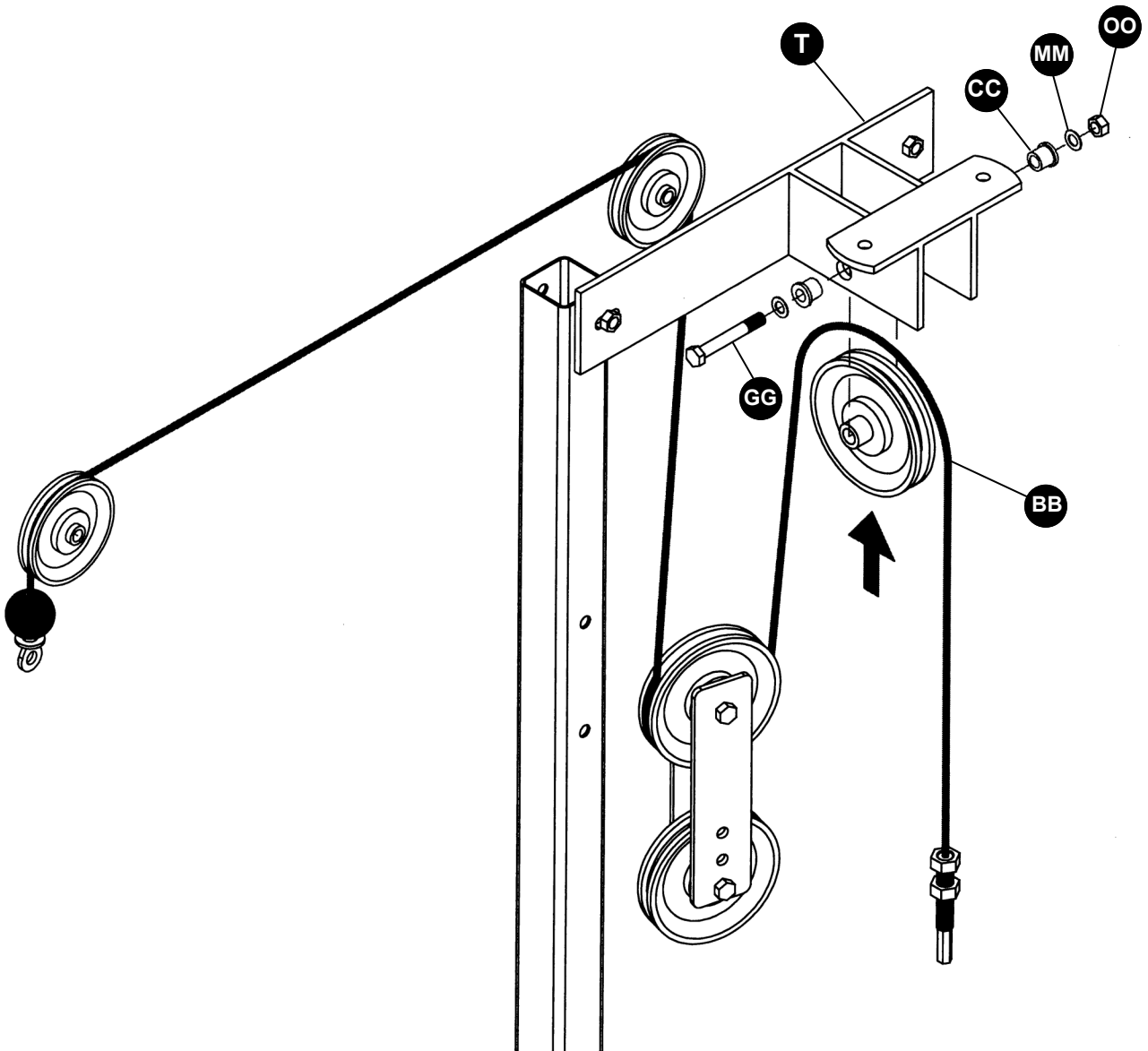

INSTALL UPPER CABLE AROUND TOP PULLEY OF FLOATING PULLEY ASSEMBLY AND THEN OVER 3-1/2" PULLEY (**BB**). INSERT 3-1/2" PULLEY INTO UPPER PULLEY FRAME (**T**) AND FASTEN WITH M10 x 70MM BOLT (**GG**), PULLEY BUSHINGS (**CC**), M10 WASHERS (**MM**), AND M10 LOCKNUT (**OO**).

UPPER CABLE INSTALLATION

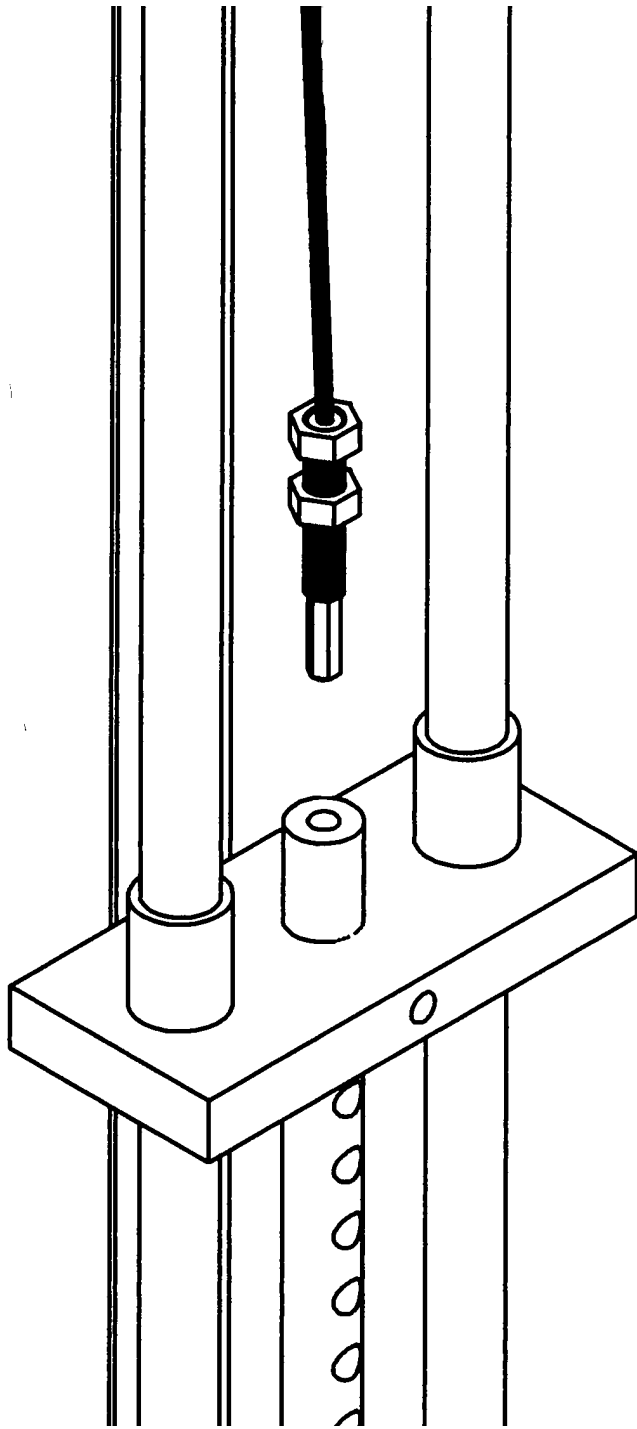

CONNECT END OF CABLE TO WEIGHT STACK TOP PLATE BY SCREWING INTO TOP OF SELECTOR ROD.

LOWER CABLE INSTALLATION

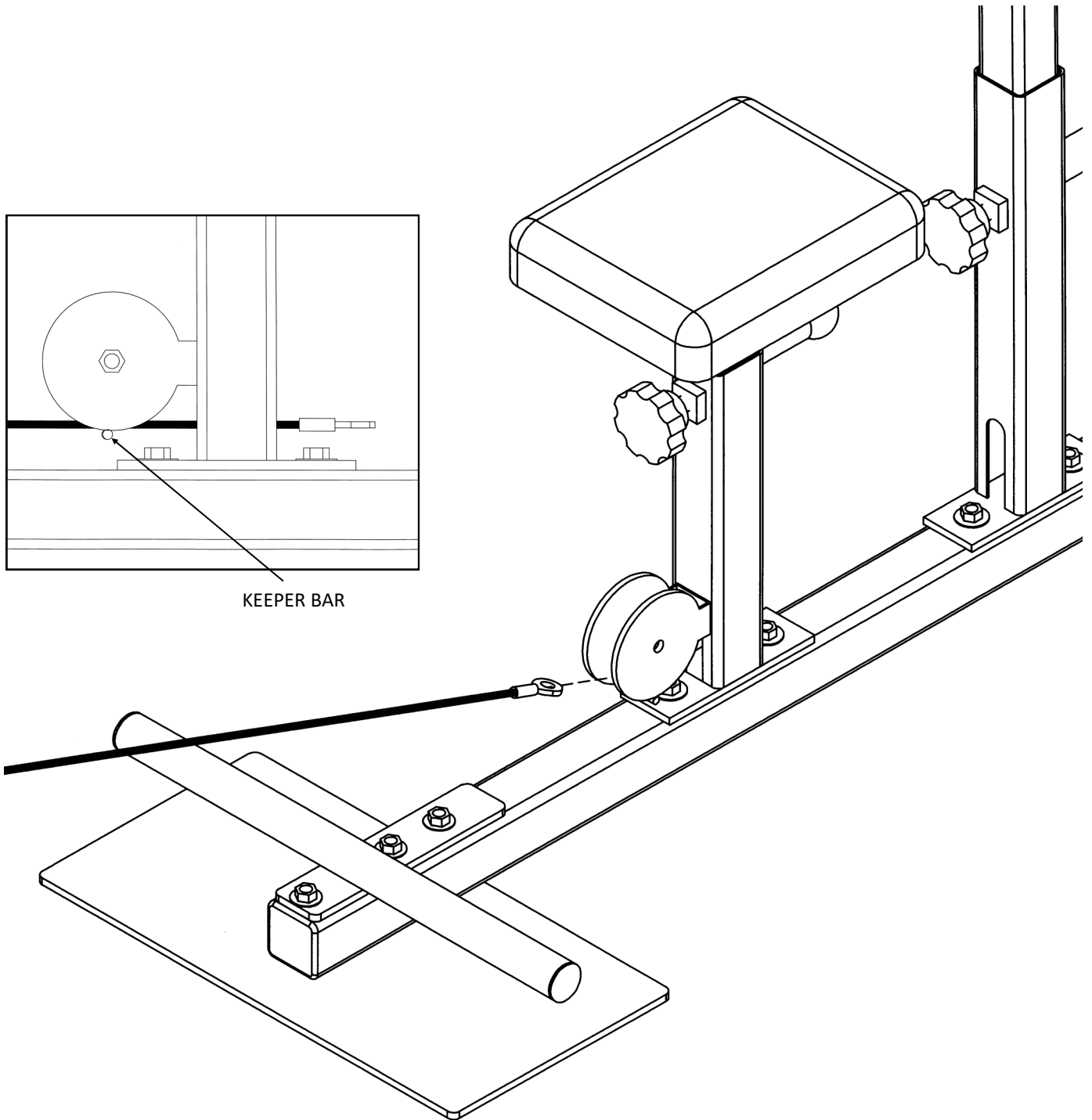

STARTING WITH THE CABLE END WITHOUT THE BALL, INSERT CABLE UNDER 3-1/2" PULLEY ON SEAT FRAME. MAKE SURE THAT CABLE IS ABOVE KEEPER BAR ON BOTTOM OF PULLEY FRAME (SEE INSET PICTURE)

LOWER CABLE INSTALLATION

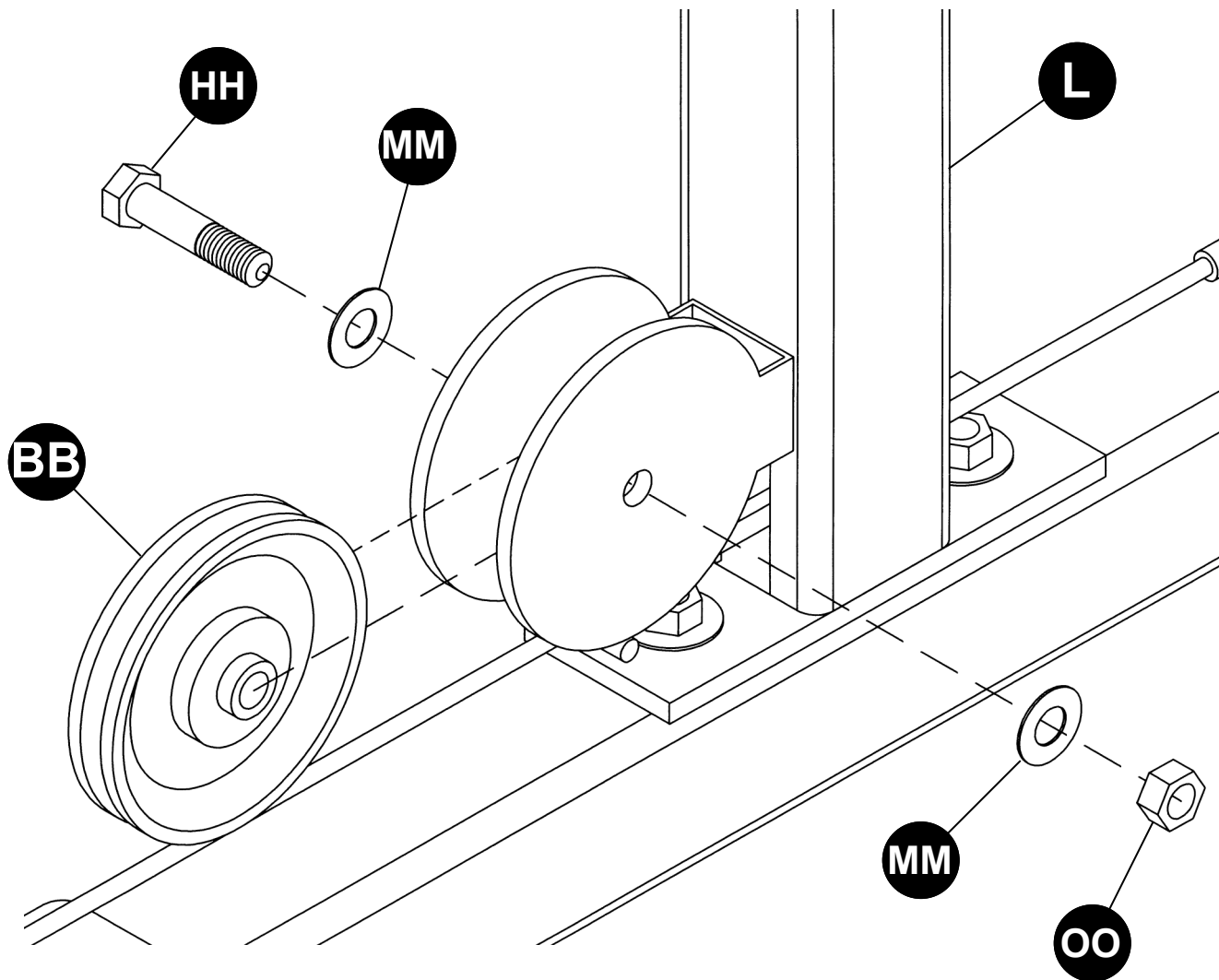

INSTALL THE 3-1/2" PULLEY (BB) INTO THE PULLEY FLANGES ON THE SEAT SUPPORT TUBE (L) USING THE M10 x 45MM BOLT (HH), M10 WASHERS (MM), AND M10 LOCK NUT (OO).

LOWER CABLE INSTALLATION

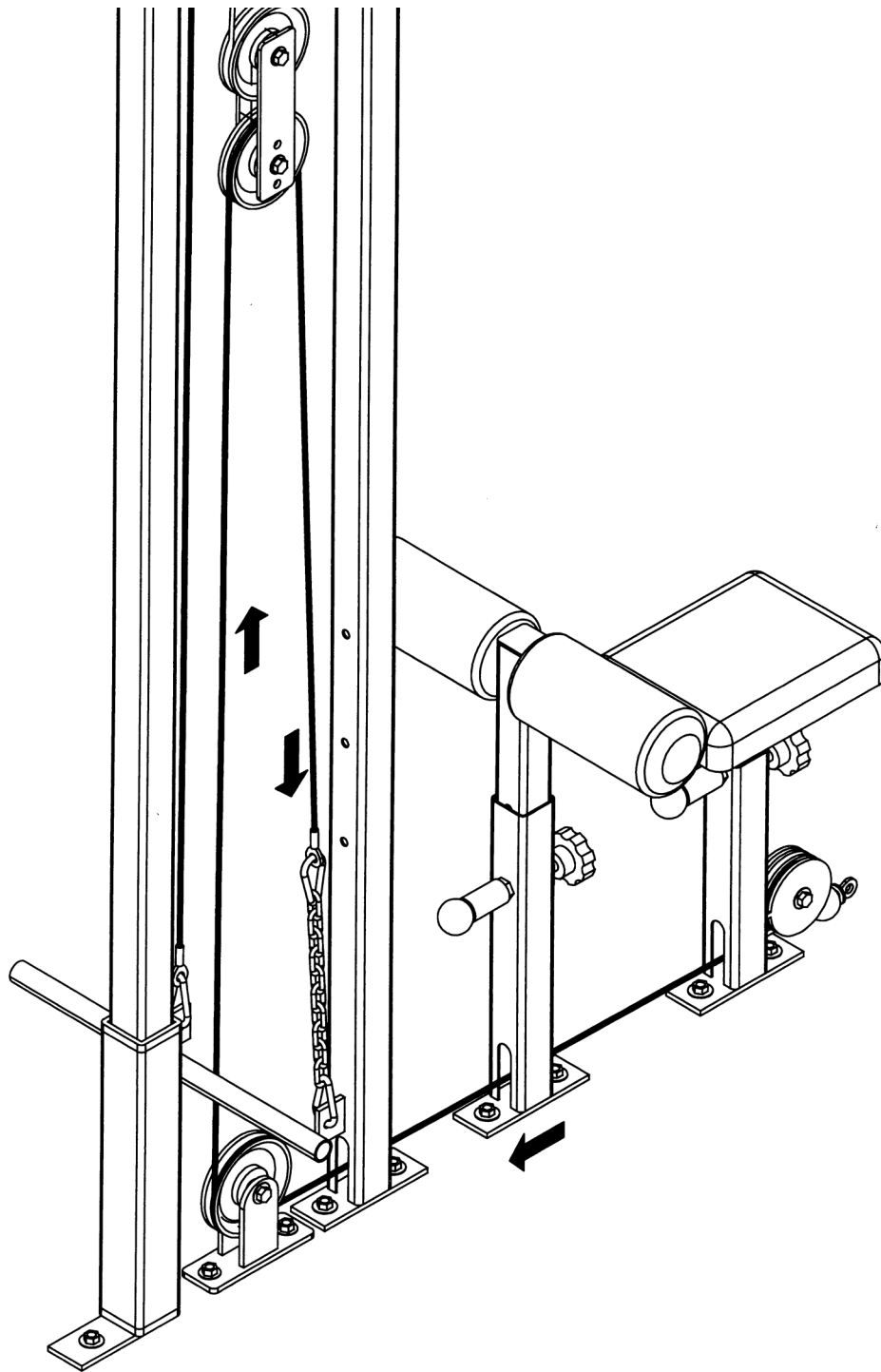

FEED CABLE THROUGH OPENINGS IN SEAT SUPPORT, HOLD-DOWN SUPPORT, AND FRONT SUPPORT. INSTALL CABLE AROUND 4-1/2" LOWER PULLEY, UP AND AROUND BOTTOM PULLEY OF FLOATING PULLEY ASSEMBLY. ATTACH CABLE TO CHAIN WITH SNAP HOOK AND ATTACH THE OTHER END OF CHAIN TO MOUNTING FLANGE AT BOTTOM OF FRONT SUPPORT WITH SNAP HOOK.

LAT BAR INSTALLATION

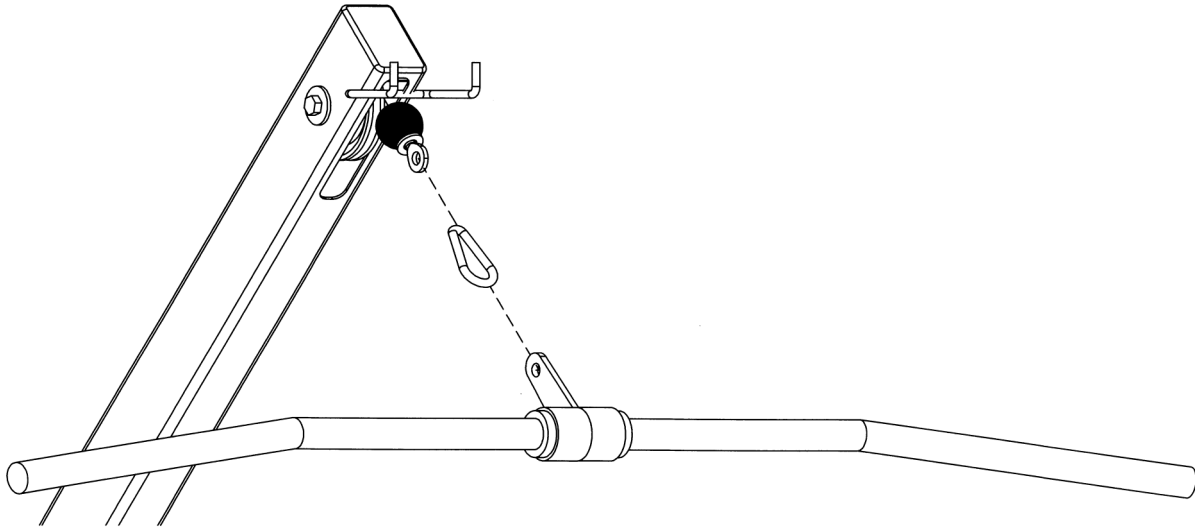

ATTACH LAT BAR TO UPPER CABLE WITH SNAP HOOK. MOVE TO CRADLE WHEN NOT IN USE.

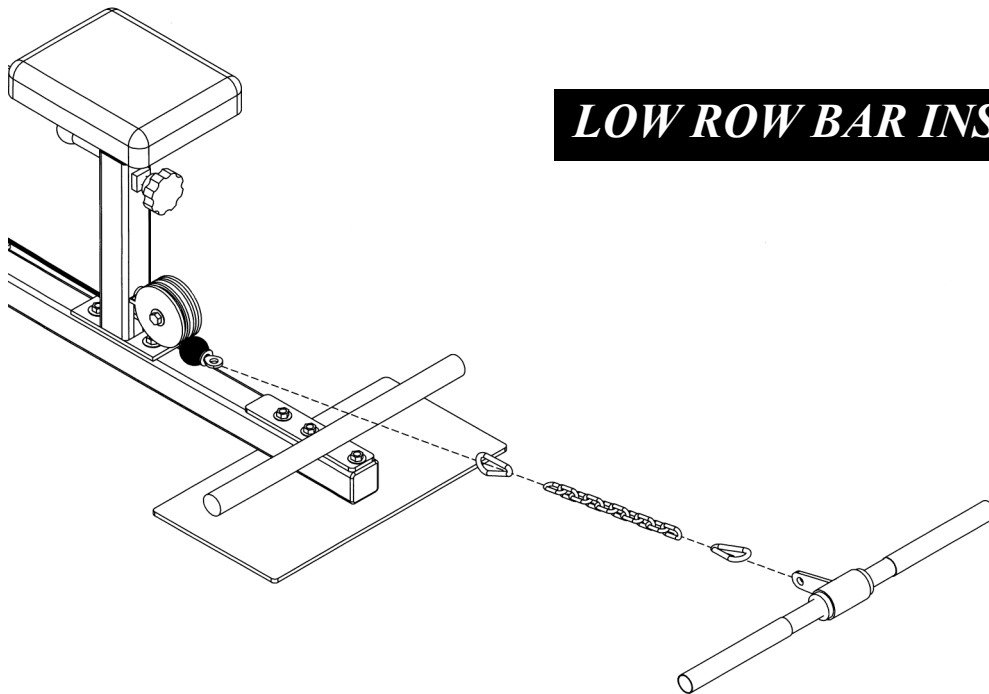

LOW ROW BAR INSTALLATION

ATTACH LOW ROW BAR TO LOWER CABLE WITH 2 SNAP HOOKS AND CHAIN. YOU CAN ALSO USE THIS CHAIN ON THE HIGH PULLEY TO DO TRICEP EXERCISES.

WEIGHT STACK PIN INSTALLATION

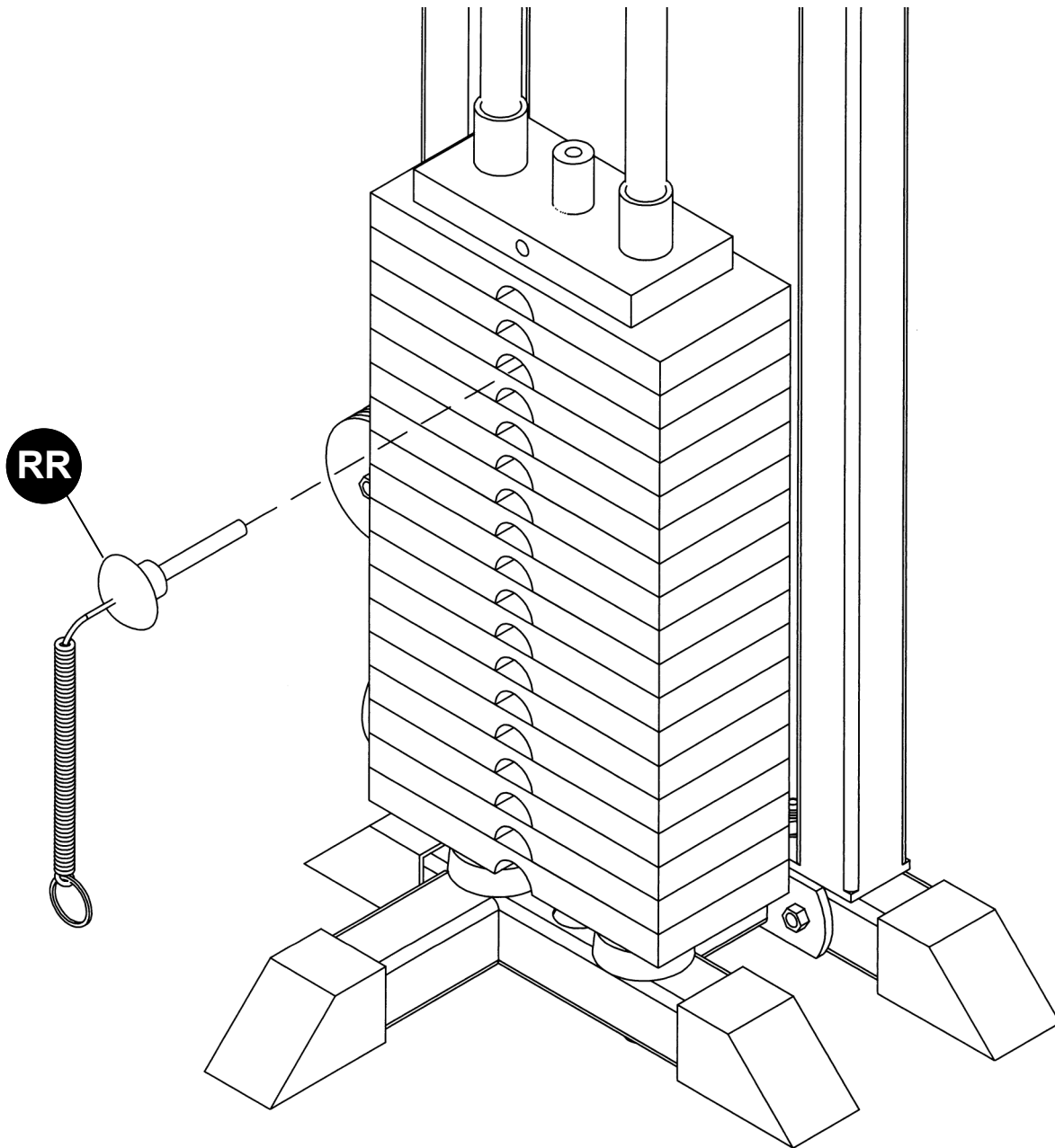

INSERT WEIGHT STACK PIN (**RR**) INTO DESIRED SETTING ON WEIGHT STACK.

SAFETY NOTICE

WARNING: THE USER OF THIS WEIGHT EQUIPMENT ASSUMES THE POSSIBILITY OF INJURY BY EXERCISING ON THIS EQUIPMENT. THE POSSIBILITY OF RISK CAN BE REDUCED BY ALWAYS FOLLOWING THESE SIMPLE RULES:

- 1) BEFORE BEGINNING ANY EXERCISE PROGRAM, CONSULT YOUR DOCTOR FOR A COMPLETE PHYSICAL EXAMINATION AND SUGGESTED EXERCISE PROGRAM SPECIFIC FOR YOU.
- 2) STRETCH BEFORE AND AFTER THE EXERCISE PROGRAM. PROPER STRETCHING WILL PREPARE YOUR JOINTS AND MUSCLES FOR EXERCISE AND HELP AVOID INJURIES.
- 3) IF AT ANY TIME YOU SHOULD FEEL FAINT OR DIZZY, NAUSEOUS OR EXPERIENCE ANY OTHER ABNORMAL SYMPTOMS OR DISCOMFORT DISCONTINUE USE AND CONSULT YOUR DOCTOR.
- 4) DO NOT USE THIS EQUIPMENT WITHOUT QUALIFIED SUPERVISION AND PROPER TRAINING. NEVER WORK OUT ALONE- ALWAYS HAVE A PARTNER.
- 5) SECURELY TIGHTEN ALL BOLTS AND REGULARLY CHECK TO ENSURE ALL BOLTS HAVE NOT LOOSENED.
- 6) WEAR GOOD RUBBER SOLE SHOES ONLY. DO NOT USE BARE FOOTED OR WITH SOCKS ONLY.
- 7) DO NOT WEAR LOOSE CLOTHES SUCH AS ROBES, GOWNS, PANTS, LONG SHIRTS OR JEWELRY WHICH COULD BECOME ENTANGLED IN MOVING PARTS.
- 8) DO NOT STAND OR KNEEL ON SEAT. ALWAYS SIT OR LAY SQUARELY CENTERED.
- 9) KEEP HEAD, LIMBS AND BODY PARTS CLEAR OF MOVING PARTS AND WEIGHT PLATES.
- 10) CHILDREN SHOULD NOT USE EXERCISE EQUIPMENT WITHOUT SUPERVISION BECAUSE OF POSSIBILITY OF INJURY FROM IMPROPER USAGE. THIS EQUIPMENT IS INTENDED FOR HOME USE ONLY.
- 11) REPLACEMENT OF WORN OR DEFECTIVE PARTS MUST BE WITH FACTORY AUTHORIZED PARTS. IF OTHER THAN FACTORY AUTHORIZED PARTS OR ASSESSORS ARE USED ALL WARRANTIES AND LIABILITIES BECOME VOID.