

***PLATINUM SPLIT TWIN***  
**VERSION 5**  
**OWNER'S MANUAL**

*Whisper***KOOL**<sup>™</sup>  
The Coolest Thing In Wine Storage

**Conforms to ANSI/UL Std 427**

**Certified to CAN/CSA Std C22.2 No. 120**

***We manufacture, test and certify 100% of our wine cooling units in the USA. By sourcing the best components and closely controlling our manufacturing processes, we can assure the highest-quality, lowest defect manufacturing rates in the industry.***

Copyright © 2022. WhisperKOOL. All rights reserved.

WhisperKOOL copyrights this manual, the product design, and the design concepts, with all rights reserved. Your rights with regard to the hardware and manual are subject to the restrictions and limitations imposed by the copyright laws of the USA. Under copyright laws, this manual may not be copied, reproduced, translated, transmitted, or reduced to any printed or electronic medium or to any machine-readable form, for any purpose, in whole or in part, without the written consent of WhisperKOOL.

Every effort has been made to ensure that the information in this manual is accurate. WhisperKOOL is not responsible for printing or clerical errors.

WhisperKOOL reserves the right to make corrections or improvements to the information provided and to the related hardware at any time, without notice.

Vinothèque and WhisperKOOL are registered trademarks, and ECE is a trademark of WhisperKOOL. All rights reserved.

Mention of third-party products is for informational purposes only and constitutes neither an endorsement nor a recommendation. WhisperKOOL assumes no liability with regard to the performance or use of these products.

# TABLE OF CONTENTS

<b>Introduction</b> .....	<b>2</b>
<b>Before You Start</b> .....	<b>3</b>
<b>Receiving &amp; Inspecting the System</b> .....	<b>4</b>
<b>Quick Reference Guide</b>	
Wall-Mounted Evaporator Unit .....	<b>5</b>
Ducted Evaporator Unit .....	<b>6</b>
Wall-Mounted Twin Specifications .....	<b>7</b>
Ducted Twin Specifications .....	<b>8</b>
Condensing Unit Specifications .....	<b>9</b>
<b>Preparing the Wine Cellar</b> .....	<b>10</b>
<b>Liquid-Measuring Thermostat (Bottle Probe)</b> .....	<b>13</b>
<b>System Operation</b> .....	<b>14</b>
<b>Controller Functions</b> .....	<b>16</b>
<b>WhisperKOOL Troubleshooting Guide</b> .....	<b>22</b>
<b>Maintenance Schedule</b> .....	<b>24</b>
<b>Technical Assistance &amp; Accessories</b> .....	<b>25</b>
<b>Installation Terms and Conditions</b> .....	<b>26</b>

## INTRODUCTION

### Customer Service

Thank you for purchasing a WhisperKOOL cooling system. We strive to provide the highest-quality products and the best possible customer service. If you have any questions about your system, please visit [WhisperKOOL.com](http://WhisperKOOL.com).

### Using the Manual

This manual is intended to assist in the proper maintenance of the cooling system. In order to ensure the longevity of your cooling unit, the equipment should be installed as outlined in the technician's manual. It is also vital to establish a proper care and maintenance schedule. Please read and review this manual carefully and keep it for future reference.

### What is the WhisperKOOL Cooling System?

The WhisperKOOL cooling system is a specialized refrigeration system designed for one purpose only: to maintain the optimal temperature and humidity levels conducive to the proper storage and aging of fine wines. This system produces minimal in-cellar noise and has the most lenient exhaust requirements. An exterior housing is required for outdoor condensing unit installations.

### How Does the Cooling System Work?

Similar to the air conditioning systems used for homes, the evaporator unit and condensing units are installed in separate locations and are connected by a refrigerant line set. The evaporator portion is commonly installed in the wine cellar, with the condensing unit is located either outside or in a remote indoor location that is ventilated. An exterior housing is required for outdoor condensing unit installations.

### Temperature Setting

The system is designed to maintain a cellar temperature of 55°F as long as the ambient temperature does not exceed 110°F.

## WARRANTY REGISTRATION

In order to activate the warranty of your system, the verification and operational documentation must be completed by the certified refrigeration technician installing your system and submitted via mail, fax, or e-mail.

Mail to:  
WhisperKOOL  
ATTN: Warranty Registration  
1738 E. Alpine Avenue  
Stockton, CA 95205-2505  
USA

Fax to:  
209-466-4606

Scan and email to:  
[warranty@whisperkool.com](mailto:warranty@whisperkool.com)



## BEFORE YOU START

1. **Inspect all components prior to installation.** If damage is found, please contact your distributor or WhisperKOOL Customer Service at support@WhisperKOOL.com.
2. Each evaporator unit **requires a dedicated 115V, 15-amp circuit.** The condensing unit **requires a dedicated 230V single-phase 15-amp circuit.** Use a surge protector with the unit. **Do not use a GFI** (ground fault interrupter) line.
3. You are **REQUIRED** to **install a drain line** to remove condensation from each evaporator unit.
4. ***The warranty is not active until a warranty checklist has been received, reviewed, and approved.***
5. The system is intended **for use in properly designed and constructed wine cellars.** Hire a professional wine storage consultant with a valid contractor's license to build your wine cellar.
6. WhisperKOOL requires that all split systems be installed by a certified HVAC-R technician only. NATE or equivalent is recommended.
7. ***It is vital that the units be set apart and oriented so that the return air from one unit does not recirculate into the supply air of the other unit.***

If you encounter a problem with your WhisperKOOL system, please refer to the Troubleshooting Guide. If you have any further questions or concerns, or need assistance, please contact WhisperKOOL's Customer Service at support@WhisperKOOL.com. Please be sure all testing has been completed prior to contacting Customer Service. Please have your results ready for your representative.

## RECEIVING & INSPECTING THE SYSTEM

- Use caution when lifting and check package for damage.
- Lift only at the designated hand-hold locations on the shipping container, or fully support the unit from underneath. A shipment may include one or more boxes containing accessories.
- Before opening the container, inspect the packaging for any obvious signs of damage or mishandling.
- Write any discrepancy or visual damage on the bill of lading before signing.
- Allow the condensing unit to sit for 24 hours prior to start-up. The condensing unit can be placed in the installation location, piped, and evacuated during this time.

**NOTE:** WhisperKOOL units are manufactured in the USA and tested prior to shipment.

- Review the packing slip to verify contents.
- Check the model number to ensure it is correct.
- Check that all factory options ordered are listed.

**If any items listed on the packing slip do not match your order information, contact WhisperKOOL Customer Service immediately.**

**Check all shipped boxes for the following contents:**

### Master Evaporator Box

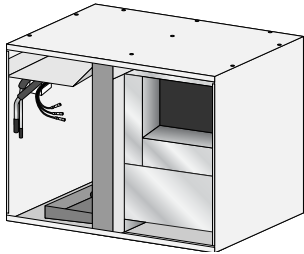

- (1) Master Platinum Split Twin evaporator unit
- (1) Wall-mounted evaporator installation template

#### Documentation bag (master):

- Platinum Split Twin owner's manual
- Platinum Split Twin technician's manual
- R-134a split system warranty checklist

#### Accessory kit bag (master):

- KDT Plus display cable (50 feet)
- KDT Plus wall mount bracket assembly
- KDT Plus flush mount bracket assembly
- KDT Plus display assembly
- Flush mount template
- Black strain relief bushing
- Evaporator installation hardware bag
- KDT Plus hardware bag

- (2) 1/2" x 1/2" 90° nylon barbed fitting
- (1) 1/2" barbed tee
- (1) Double-D strain relief
- (4) 3/4" adhesive cable tie mounts
- (2) Small cable ties
- (4) #8 x 1 3/4" hex-head screws

- (1) 1 1/16" OD grommet
- (2) 1/2" nylon hole plugs
- (4) #6 x 1" PHP zinc Type A screws
- (4) 8-10 x 7/8" blue plastic screw anchors

- (2) 1/2" x 1/2" 90° nylon barbed fitting
- (1) 1/2" barbed tee
- (1) Double-D strain relief
- (4) 3/4" adhesive cable tie mounts
- (2) Small cable ties
- (4) #8 x 1 3/4" hex-head screws

### Slave Evaporator Box

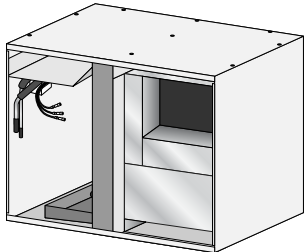

- (1) Slave Platinum Split Twin evaporator unit
- (1) Wall-mounted evaporator installation template
- (1) Evaporator installation hardware bag

#### Ducted Master Accessory Kit Box

- (1) Stainless steel bottle probe (50-ft cord)
- (1) Duct plenum

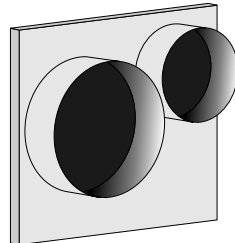

OR

#### Wall-Mounted Master Accessory Kit Box

- (1) Retractable bottle probe
- (1) Filter grille

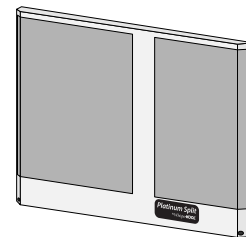

### Condensing Unit Box

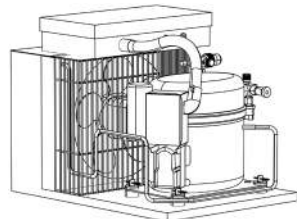

- (1) Condensing unit
- (1) Condensing unit accessory kit:
  - (1) 1/4" filter drier
  - (1) 1/4" sight glass

#### Ducted Slave Accessory Kit Box

- (1) Duct plenum

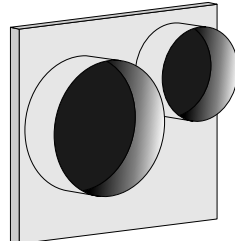

OR

#### Wall-Mounted Slave Accessory Kit Box

- (1) Filter grille

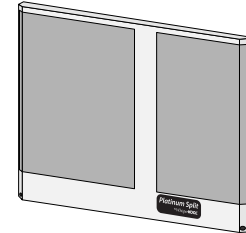

Please leave the unit in its original box until you are ready for installation. This will allow you to move the product safely without damaging it. When you are ready to remove the product from the box, refer to the installation instructions.

**TIP:** Save your box and all packaging materials. They provide the only safe means of transporting/shipping the

# QUICK REFERENCE GUIDE

Front / Side View

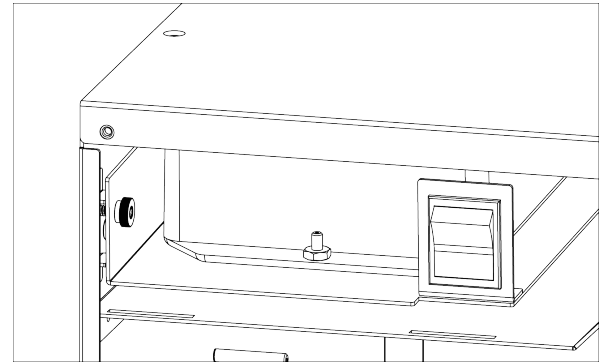
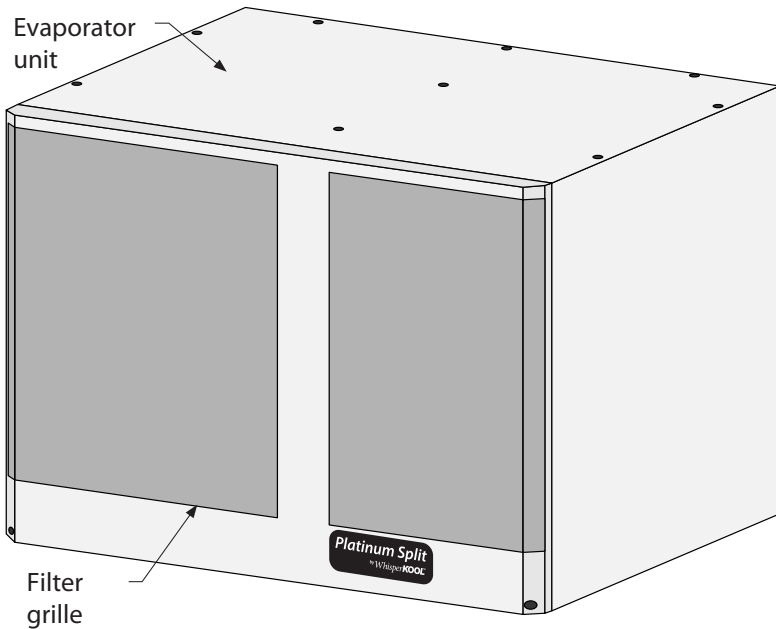

## Fan Speed Switch

The cooling system comes equipped with a variable fan speed switch. Increasing the fan speed increases the volume of cool air blown from the system. It is set by the factory to MED. To access the fan speed switch it is necessary to remove the front grille.

Wall-Mounted — Rear / Side View

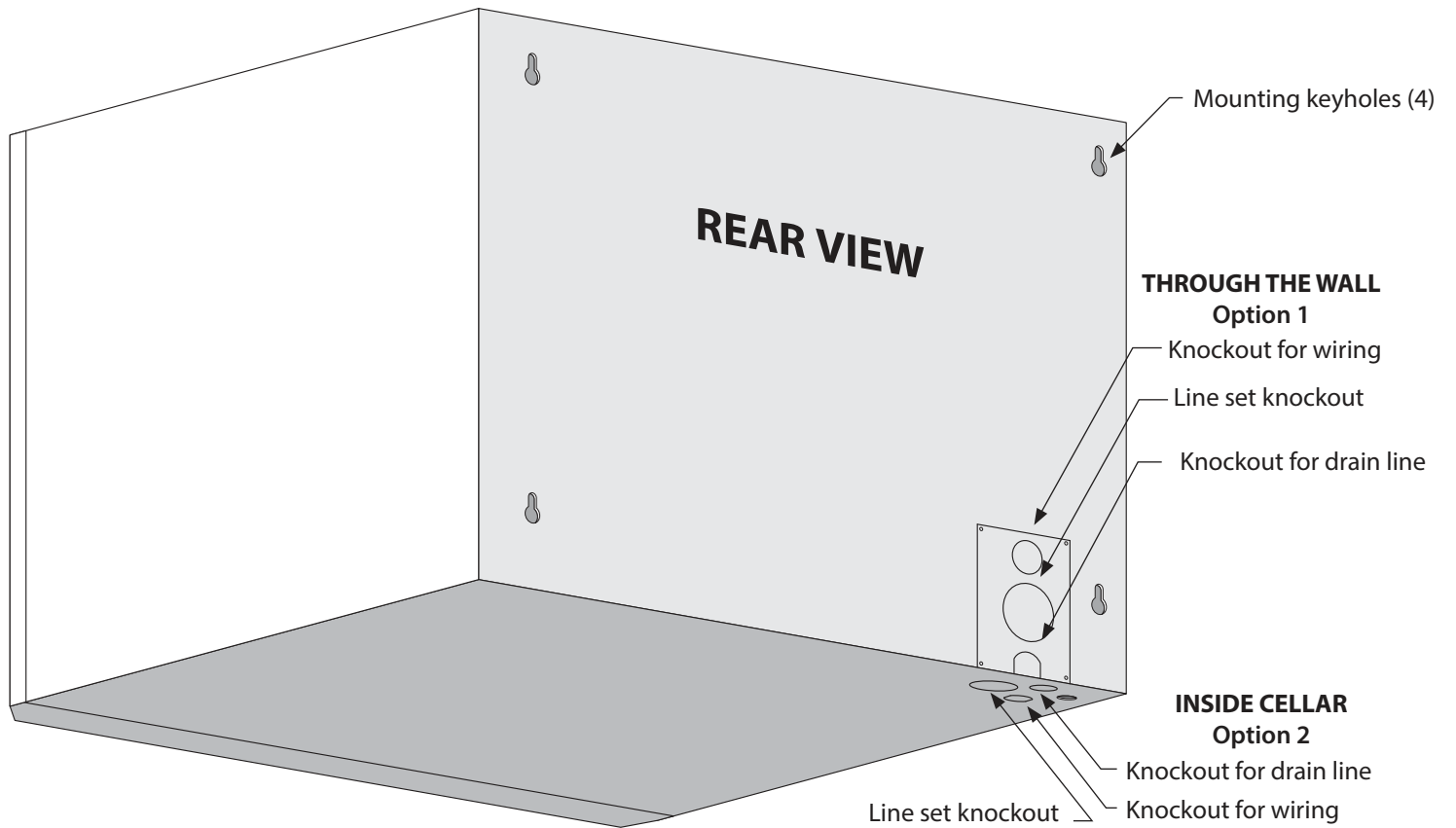

Ducted — Front / Side View

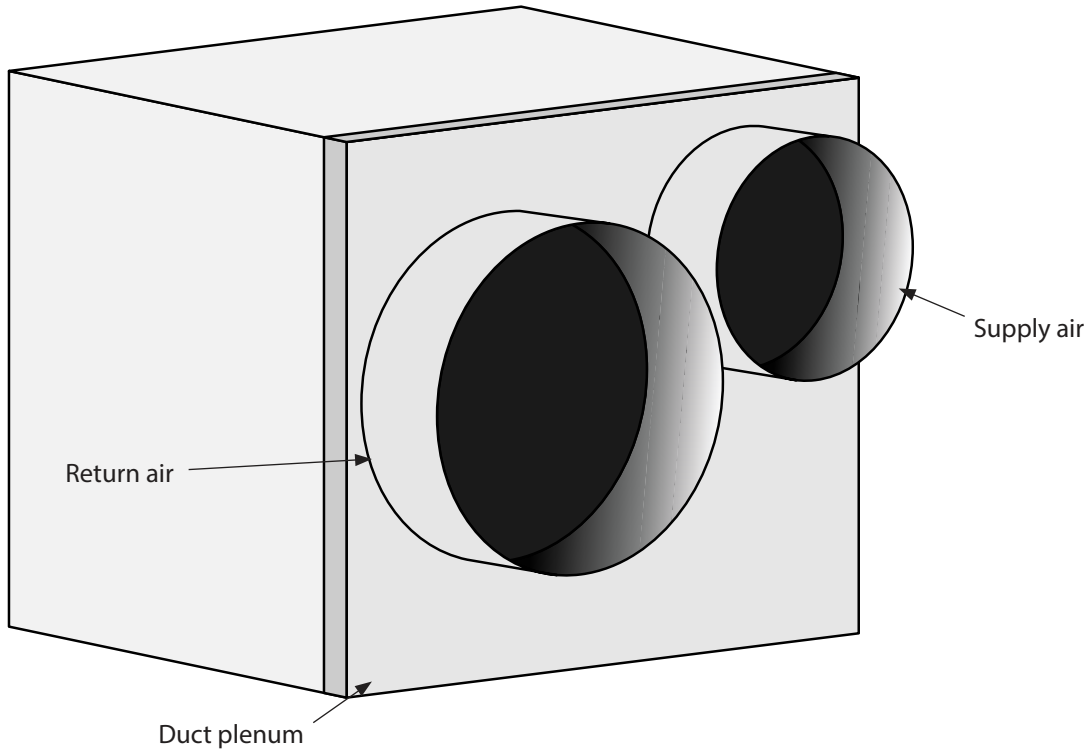

Ducted — Rear / Side View

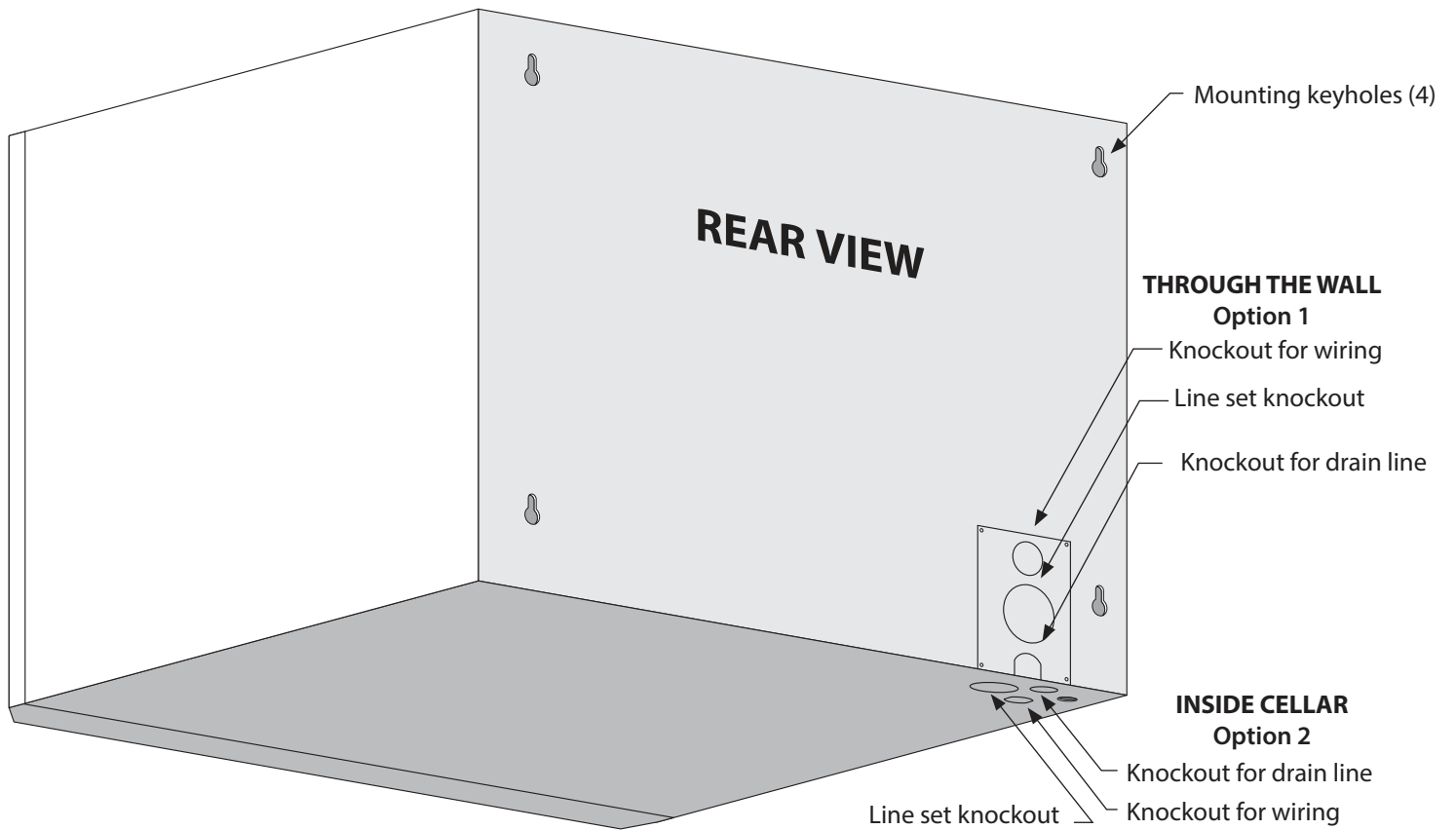

# WALL-MOUNTED TWIN SPECIFICATIONS

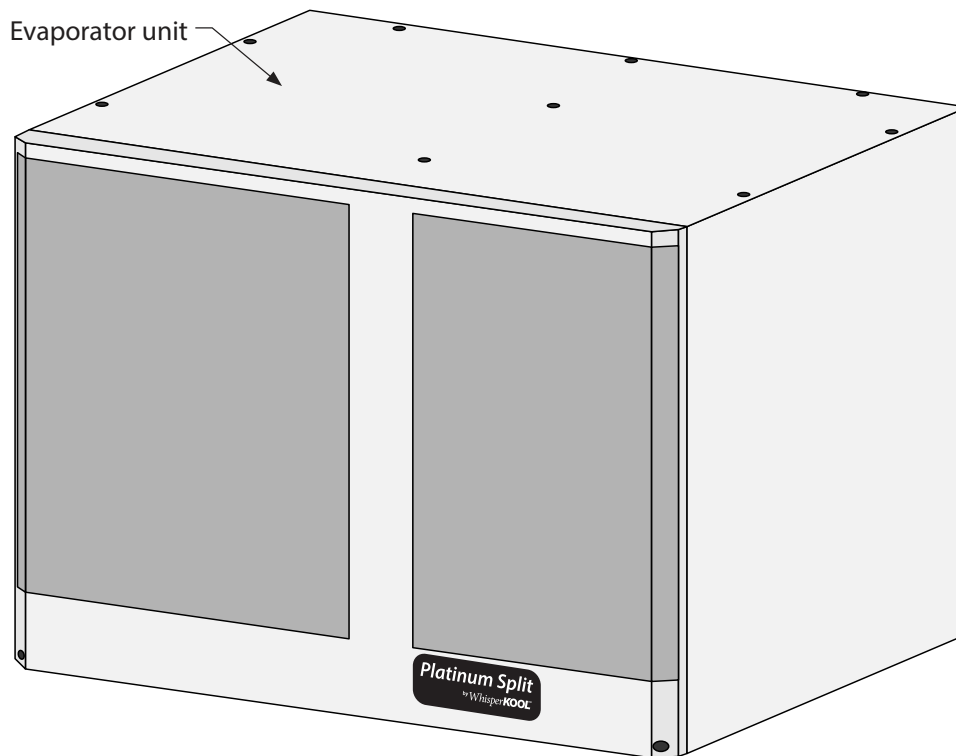

Model	9000 Master Evaporator (Fan Coil Unit)	9000 Slave Evaporator (Fan Coil Unit)
Cellar Size	Approx. 3000 cu. ft., provided cellar is fully insulated and sealed with proper vapor barrier*	
BTU/h w/85°F air entering condenser coil	Low: 6843/7845 • Medium: 7368/7959 • High: 7779/8054	
Dimensions	16.1"L x 20.5"W x 15.5"H	16.1"L x 20.5"W x 15.5"H
Refrigerant	R-134a	R-134a
Voltage Rating	115V (15-amp dedicated circuit required)	115V (15-amp dedicated circuit required)
Weight (lbs)	57	57
Amps	Evaporator: 1 running amp (per unit) Compressor: LRA 50, RLA 9.3	Evaporator: 1 running amp (per unit) Compressor: LRA 50, RLA 9.3
Line Set	Liquid line 3/8"; suction line 3/4" (less than 50 ft.), 7/8" (greater than 50 ft.)	
Drain Line	1/2" ID clear plastic tubing (not provided)	
Installation	Evaporator units are installed in the cellar.	
Thermostat	Advanced digital display (50-ft. cable), liquid-temperature-measuring bottle probe (50-ft. cable)	
Temp. Delta	Can maintain a 55°F temperature differential with up to 110°F condenser air intake temperature	
Warranty	Two-year limited warranty (parts and labor)	

\*Each cellar is unique and has specific cooling requirements. Heat load calculations should always be performed prior to selecting a cooling unit.

# FULLY DUCTED TWIN SPECIFICATIONS

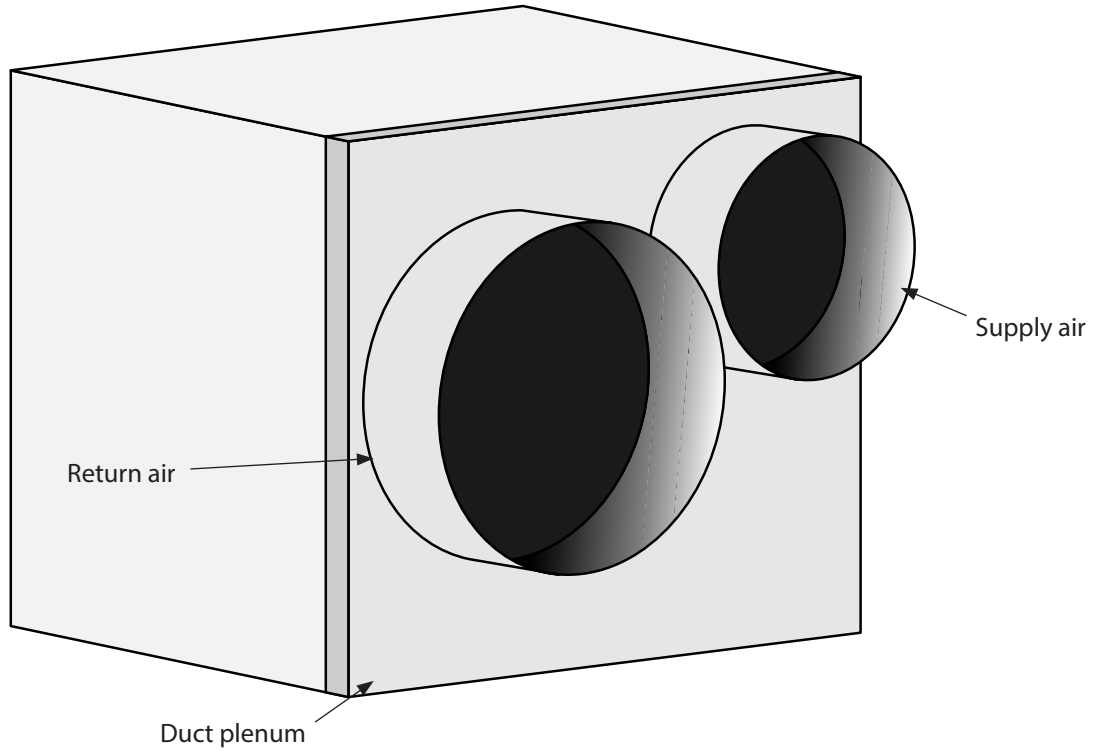

Model	9000 Master Evaporator (Fan Coil Unit)	9000 Slave Evaporator (Fan Coil Unit)
Cellar Size (cu. ft.)	Approx. 3000 cu. ft., provided cellar is fully insulated and sealed with proper vapor barrier*	
BTU/h w/85°F air entering condenser coil	Low: 6450/7366 • Medium: 7083/7657 • High: 7281/7879	
Dimensions	22.1"L x 22.5"W x 15.5"H	22.1"L x 22.5"W x 15.5"H
Refrigerant	R-134a	R-134a
Voltage Rating	115V (15-amp dedicated circuit required)	115V (15-amp dedicated circuit required)
Weight (lbs)	57	57
Amps	Evaporator: 1 running amp (per unit) Compressor: LRA 50, RLA 9.3	Evaporator: 1 running amp (per unit) Compressor: LRA 50, RLA 9.3
Line Set	Liquid line 3/8"; suction line 3/4" (less than 50 ft.), 7/8" (greater than 50 ft.)	
Duct Size	8" supply, 10" return (x2)	
Drain Line	1/2" ID clear plastic tubing (not included)	
Installation	Evaporator units can be installed up to 25 ducted feet away.	
Thermostat	Advanced digital display (connected to master unit) with 50-ft. cable; liquid-temperature-measuring bottle probe (also with 50-ft. cable)	
Temp. Delta	Can maintain a 55°F cellar temperature with up to 110°F condenser air intake temperature	
Warranty	Two-year limited warranty (parts and labor)	

\*Each cellar is unique and has specific cooling requirements. Heat load calculations should always be performed prior to selecting a cooling unit.

**CONDENSING UNIT SPECIFICATIONS**

Model	9000 Condenser (Air-Cooled Condensing Unit)
Dimensions	24"L x 18.98"W x 16.16"H
Refrigerant	R-134a
HP	Ducted system: 3.1, non-ducted system: 3.34
Voltage Rating	230V (15-amp dedicated circuit required)
Weight (lbs)	75
Installation	Condensing unit can be installed up to 100 line feet from master evaporator unit.
Warranty	Two-year limited warranty (parts and labor)

## PREPARING THE WINE CELLAR

The performance and life of your system is contingent upon the steps you take in preparing the wine cellar. Improperly preparing your enclosure or incorrectly installing your unit may cause unit failure, leaking of condensation, and other negative side effects.

**It is highly recommended that you obtain the assistance of a wine storage professional.**

Wine storage professionals work with licensed contractors, refrigeration technicians, and racking companies to build well-insulated, beautiful, and protective wine cellars. WhisperKOOL has put together some useful tips to assist in the installation process. Our recommendations are meant to act as a guide in the process of building a proper enclosure. Your intended location may have specific needs which we do not address.

### Wall & Ceiling Framing

Build wine cellar walls using standard 2x4 or 2x6 boards and ceiling joists without violating local or state codes in your area. As a general rule, the thicker the walls and the higher the insulation value, the more consistent your cellar temperature will be.

### Insulation

Insulation is **REQUIRED** in order to properly use WhisperKOOL products. It is vital that all walls and ceilings be insulated to keep the cellar temperature as consistent as possible during the summer and winter months. Standard fiberglass or rigid foam insulation is normally used in cellar construction; in some cases, “blown-in” insulation is used. The R-value, or quality of insulation, is determined by the rate at which heat passes through the insulation. The higher the R-value, the more resistant the insulation is to conducting heat, and the more consistent your wine cellar’s temperature will be. Using higher R-values in insulation will lower your operating costs and WhisperKOOL unit run time. (R-13 is the recommended minimum; R-19 is preferred for interior cellar walls, and R-30 for ceilings and exterior walls.)

### Vapor Barrier

Water vapor creates its own pressure, separate from the ambient air pressure, and will intrude into colder/drier areas. A vapor barrier is **REQUIRED** in order to prevent the intrusion of water vapor and maintain the correct cellar temperature and humidity. It is recommended that 6-millimeter plastic sheeting be applied to the warm side of the cellar walls. The vapor barrier must also be applied to the outside walls and ceiling. If it is impossible to reach the outside, then the plastic must be applied from within the cellar. The most common method is to wrap the entire interior, leaving the plastic loose in the stud cavity so the insulation can be placed between each stud. All of the walls and ceiling must be wrapped in plastic for a complete vapor barrier.

In areas of high humidity, such as Southern and Gulf States, the vapor barrier will prevent infiltration of warm moist air. The moist air can cause mold to form, and standing water in drain pans promote microbial and fungal growth that cause unpleasant odors and indoor air quality problems. If mold is found, remove it immediately and sanitize that portion of the unit.

**Note:** High humidity significantly increases the heat load on the cooling system.

Any break in the vapor barriers (cut, nail hole, over-lapping, etc.) will cause a moisture leak and must be sealed. The electric conduit is a “duct” for vapor to travel in. The conduit should be caulked and sealed on the warm air end.



## Mounting the Evaporator Units

The evaporator units must be mounted within 18" of the top of the room in order to achieve sufficient cooling. As the room cools down, the warm air will rise to the ceiling. Mounting the units high in the room will create a consistently cool environment by capturing the warm air and replacing it with cool air. Mounting the units low in the room will result in a temperature variation in the room due to the units' inability to draw warm air from the ceiling of the cellar to the units themselves, and cold air settling to the floor.

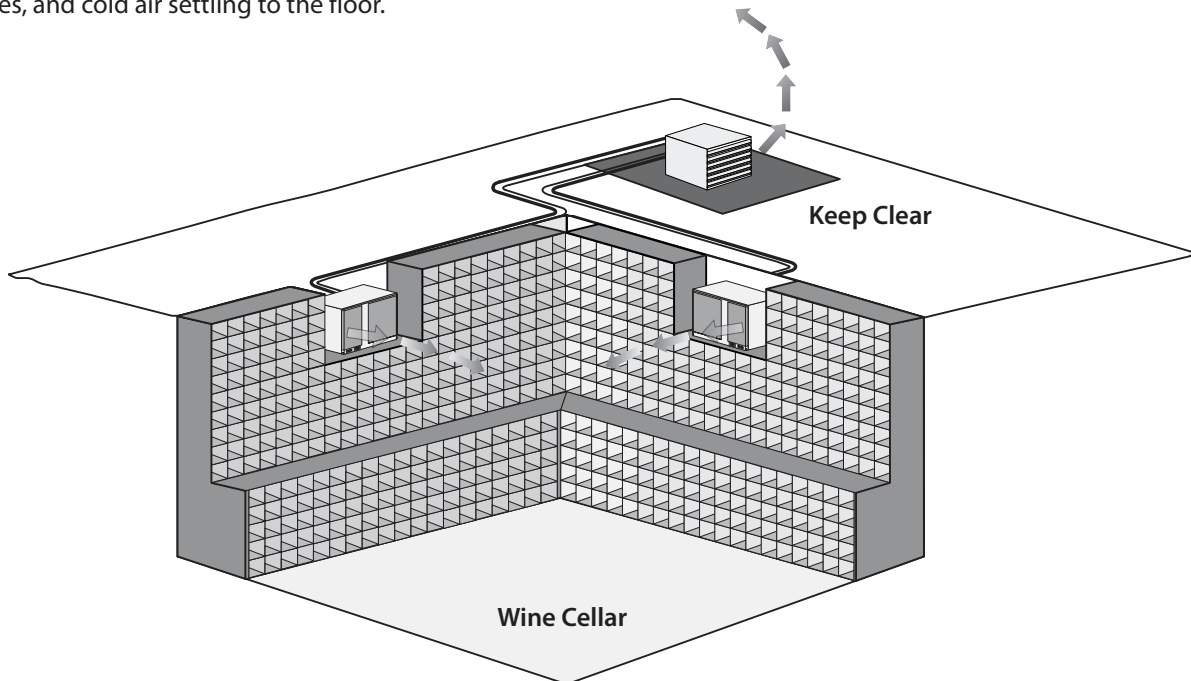

### Unobstructed Airflow

Unobstructed airflow to and from the system is critical for the system's overall performance and lifespan. Make sure there is a minimum of three (3) feet of horizontal clearance in every direction around the units (five feet is ideal). The air blown by the fans needs to circulate and either dissipate or absorb heat from the space. The system will operate more efficiently with a greater amount of air to exchange.

**NOTE:** Avoid attempting to camouflage the units. This will restrict airflow and thus the system's ability to work efficiently.

**NOTE:** For ducted systems, every 90° bend in the ducting causes the system to lose 13 CFM of airflow.

### Door and Door Seal

An exterior grade (1 $\frac{3}{4}$ " ) door must be installed as a cellar door. It is essential that weather stripping is attached to all 4 sides of the doorjamb. A bottom "sweep" or threshold is also required. The door must have a very good vapor seal to prevent warmer moist air from leaking into the cellar. One of the most common problems with cooling systems running continually is due to the door not sealing properly. **In cases where glass doors are used and the room size is close to the recommended system size, the next larger size WhisperKOOL system should be used.** This will compensate for the insulation loss due to the lower insulating rating of glass.



## Ventilation

The necessity of dissipating heat away from the condensing unit is critical to the unit's performance and cannot be overstated. As the system operates and cools, a greater amount of heat is generated on the condensing side of the system. Adequate ventilation is required in order to dissipate heat away from the condensing unit. If ventilation is inadequate, the exhaust will heat up the area or room and adversely affect the systems ability to cool. In some cases, it may be advisable to install a vent fan to dissipate heat within the exhaust area on the condensing side of the system. However, you must have a fresh air inlet as well.

**NOTE:** If you are unsure about having adequate ventilation in your install location, please contact us to assess your specific installation at [support@whisperkool.com](mailto:support@whisperkool.com) or 1-800-343-9463.

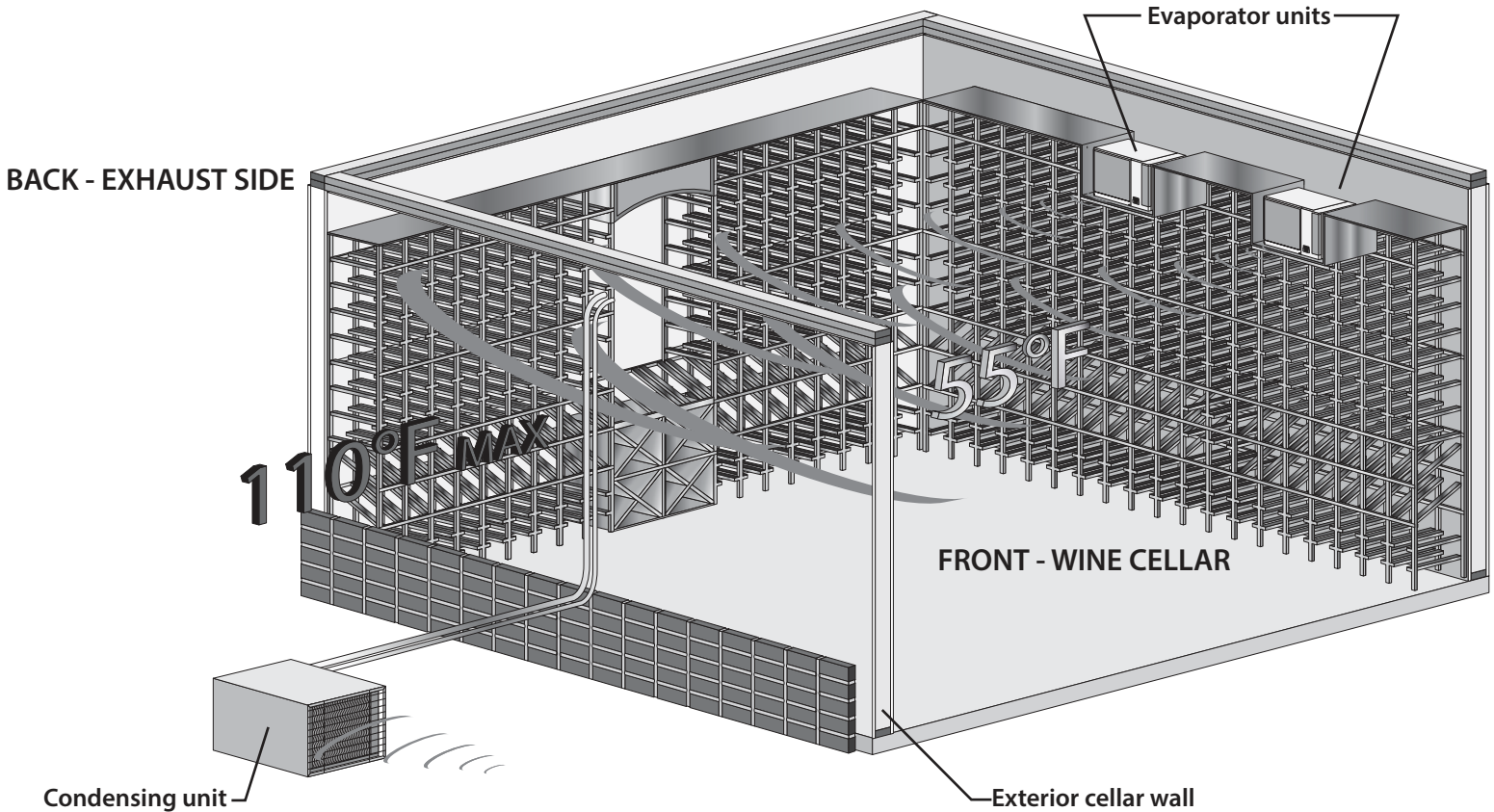

## Ambient Temperature Factor

The cooling system has the ability to cool a wine cellar efficiently to 55°F as long as the ambient temperature of the area that it is exhausting to does not exceed 110°F. Therefore, you want to exhaust the condensing unit in a space which will not exceed 110°F. Otherwise the system will not have the capacity to keep the wine at a desirable 55°F.



**WARNING! Allowing your system to operate in high ambient temperatures for extended periods of time will greatly decrease the life of your system and void your warranty. The cooler the temperature of the air entering the condenser coil, the more cooling capacity the system has. The less heat gain through the common wall, the less the electricity consumption.**



## LIQUID-MEASURING THERMOSTAT SYSTEM (BOTTLE PROBE)

WhisperKOOL cooling units come with a liquid-temperature-measuring thermostat. The self-calibrating probe contains a sensor chip, which communicates back and forth with the thermostat. This results in a consistent temperature setting and accuracy. Wine should be kept at a very precise, controlled temperature and humidity. By measuring the liquid temperature rather than air, the unit will operate 75–80% of the time.

### Setting up the Bottle Probe:

1. Locate an empty wine bottle.
2. Fill it 75% full with room-temperature tap water.
3. Place bottle probe securely into bottle as seen in Figure 1.
4. Place bottle off to the side of the unit in your wine cellar, with the probe level.
5. To ensure a consistent temperature, place bottle probe approximately three (3) feet away from the air output and not in the flow of the air.

**It is recommended that the bottle be placed in a central location of your wine cellar.** Avoid pulling too much on the probe cord. It may become disconnected resulting in limited functionality of the unit.

**NOTE:** The thermostat can be set between 50–70°F.

**Remember:** The unit operates based on the temperature of the water. Do not be misled by thermostats reading air temperature. The air temperature in the cellar will be cooler than the liquid temperature of the wine while it is reaching the optimum balanced temperature.

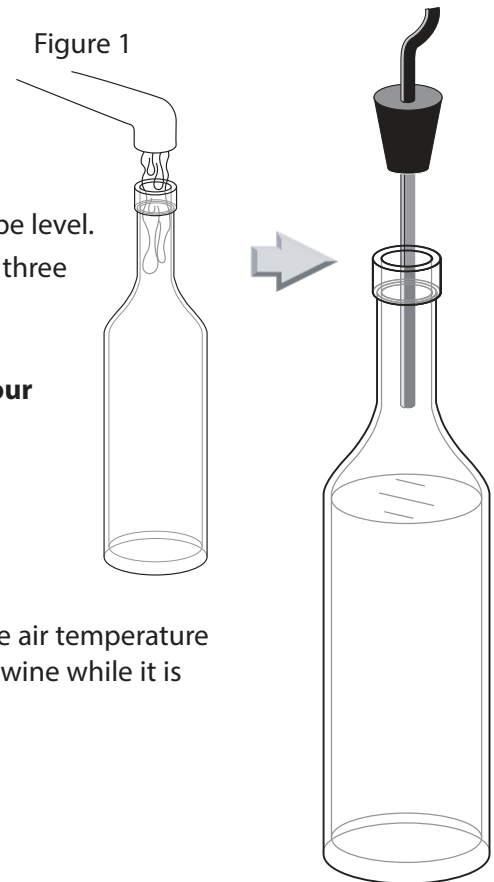

## SYSTEM OPERATION

### Initial Start-Up

When the unit is plugged in and power is sent to the controller, a beep will sound, confirming that the controller is getting power. All LEDs on the display will blink three times. Three dashes will then appear on the screen. All display LEDs will then blink three times. Once the controller has gone through the initial startup process, and all LEDs have cycled, the home screen will be displayed.

### Setpoint

The setpoint is preset at the factory to 55°F. It can be adjusted by the customer between 50–70°F in one-degree increments.

### Indoor Fan Operation

The indoor fan will run when the controller is calling for cooling and turn off once the cooling cycle has ended. During the cooling cycle, the system will remove some relative humidity from the cellar. Some of the humidity that was removed can be reintroduced into the cellar by adjusting the “fan on” and “fan off” functions. (The cooling system is not equipped with a humidifier and does not add humidity.)

The FOF cycle should be shortened first. This will reduce the amount of time that the fan remains off following a cooling cycle. When the unit has completed a cooling cycle, the compressor and the condenser fan will turn off, but the indoor fan will continue to run for whatever length of time the customer has set. The Fon function may then be lengthened to allow the fan to run longer and reintroduce moisture from the evaporator coil back into the wine cellar.

For more information about fan settings, refer to the User Menu on page 19.

### Anti-Short Cycle

The Anti-Short Cycle ensures that the unit will remain off for a period of five minutes after the unit has reached the setpoint. This allows the pressure in the refrigeration system to equalize prior to starting the compressor.

Once the solenoid relay is de-energized, the controller must wait five minutes before reenergizing the relay. This prevents the compressor from repeatedly turning off and on. If the unit is calling for cooling during this time, the compressor icon will blink, indicating that cooling is needed but the controller is waiting for the Anti-Short Cycle delay.

### Anti-Frost Cycle

When the evaporator probe senses a temperature of 26°F for a duration of one minute, an Anti-Frost Cycle will be initiated. This will shut down the compressor, allowing the evaporator fan to run and melt any frost accumulation on the coil. While the Anti-Frost Cycle is running, “dEF” will be displayed on the screen.

The compressor will remain off until the evaporator coil reaches 40°F, or for a maximum of one hour. The unit will then return to normal operation.

### Operation in Low Ambient Temperatures

The condensing unit comes equipped with a LAC (Low Ambient Control). The LAC is a three-way modulating valve that responds to discharge pressure. When the discharge pressure falls below the valve’s dome pressure, the valve modulates open to the discharge port which allows discharge gas to bypass the condenser. Mixing the discharge gas with the liquid creates high pressure at the condenser outlet, reducing the flow and causing liquid to backup in the condenser. Flooding the condenser reduces the area available for condensing. This reduction in condenser surface area results in a rise in condensing pressure during cold ambient conditions.

The condensing unit controller is preset at the factory. The cut-in pressure is preset to 25psi and the cut-out pressure at 15psi. During low ambient temperatures (40°F or below), it will be necessary to adjust the cut-in pressure to 10-15psi (15psi is preferred) and the cut-out to 5psi to ensure compressor startup. See page 20 for instructions on adjusting the cut-in and cut-out pressures of the condensing unit.

### Digital Display

The display is designed to give the user the ability to adjust the setpoint, Fon/FOF parameters, and other settings. (See User Menu on page 19 for more details.) The bottle probe temperature is displayed by default. “dEF” will be displayed during an Anti-Frost Cycle. The bottle probe and evaporator probe temperatures can be accessed by pushing the SET button and scrolling through “Pb1” (bottle probe) and “Pb2” (evaporator probe). The light button may be used as an unlock button.

### Safety Features

In the event of a faulty bottle probe, the compressor will cycle off for 10 minutes and on for 40 minutes. “E1” will be displayed on the screen.

### Alarms

See “Alarm Codes” in the Controller Functions chart.

# DISPLAY LAYOUT

❄️ Compressor is on      📡 Alarm is present  
🌀 Fan is on  
❄️ Anti-Frost Cycle running



Return to Previous Menu

View/Change Setpoint  
Enter User Menu  
*(hold for 3 sec)*





Power On/Off

Scroll Button  
Change Setpoint

Scroll Button  
Change Setpoint





Unlock Button  
*(hold for 1 sec)*

## CONTROLLER FUNCTIONS



Button	Normal Functions								
<p><b>INITIAL STARTUP</b></p>	<p>When the unit is plugged in and power is sent to the controller, a beep will sound, confirming that the controller is getting power. All LEDs on the display will blink three times. Three dashes will then appear on the screen. All display LEDs will then blink three times. Once the controller has gone through the initial startup process, and all LEDs have cycled, the home screen will be displayed.</p>								
<p><b>UNLOCKING THE DISPLAY</b></p>	<p>Press and hold any button for one second to unlock the display. (A white LED will appear in the top left corner of the button being pressed.) A beep will sound, signifying that the display is unlocked. <b>NOTE:</b> The display must be unlocked before any button functions become available.</p>								
<p><b>ON/OFF</b></p> 	<p>To turn the unit ON, press and hold the ON/OFF button until the red LED turns OFF.</p> <p>To turn the unit OFF, press and hold the ON/OFF button until the red LED turns ON.</p>								
<p><b>UP/DOWN</b></p> 	<p>The up and down arrows are used to navigate through menus and adjust parameters such as setpoint, Fon/FOF, etc.</p>								
<p><b>SET</b></p> 	<ul style="list-style-type: none"> <li>To change the setpoint, press the SET button. When "SEt" is displayed on the screen, press the SET button once more. Use the UP and DOWN ARROW buttons in order to change the value until the desired setpoint is reached.</li> <li>The SET button allows you to view the setpoint, evaporator temperature, bottle temperature, alarms, and the hidden menu.</li> <li>Press the SET button once. "SEt" will be displayed. Press the UP or DOWN ARROW buttons to scroll through ALr, Pb1, or Pb2.</li> </ul> <table border="1" data-bbox="467 1188 1511 1354"> <thead> <tr> <th>Set</th> <th>Setpoint</th> </tr> </thead> <tbody> <tr> <td><b>ALr</b></td> <td>Alarm folder</td> </tr> <tr> <td><b>Pb1</b></td> <td>Liquid (bottle probe) temperature</td> </tr> <tr> <td><b>Pb2</b></td> <td>Evaporator coil temperature</td> </tr> </tbody> </table> <ul style="list-style-type: none"> <li>Press the SET button again to view any of these values.</li> <li>Hold the SET button for approximately 5 seconds to enter the User Menu. (More information about the User Menu is available on page 19.)</li> <li>Other parameters in the User Menu which are not available for adjustment include: idF, rEL, and LAN.</li> </ul>	Set	Setpoint	<b>ALr</b>	Alarm folder	<b>Pb1</b>	Liquid (bottle probe) temperature	<b>Pb2</b>	Evaporator coil temperature
Set	Setpoint								
<b>ALr</b>	Alarm folder								
<b>Pb1</b>	Liquid (bottle probe) temperature								
<b>Pb2</b>	Evaporator coil temperature								
<p><b>ESC</b></p> 	<p>This button confirms changes made to parameters such as the setpoint and returns you to the previous menu.</p>								
<p><b>LIGHT</b></p> 	<p>The light function is not in use. However, this button can still be used to unlock the display.</p>								



## ICON GLOSSARY

Icon	Meaning
<b>SNOWFLAKE</b> 	<p><b>Blinking:</b> The unit is calling for cooling, but must wait five minutes before restarting the compressor. This five-minute delay serves as an Anti-Short Cycle for the compressor's protection.</p> <p><b>Constant:</b> The unit is in cooling mode and the condensing unit is running.</p>
<b>DRIPPING SNOWFLAKE</b> 	<p>The unit is undergoing an Anti-Frost Cycle. While the Anti-Frost Cycle is running, "dEF" will be displayed on the screen. See System Operation page for further details.</p>
<b>FAN</b> 	<p>The evaporator fan is running.</p>
<b>ALARM</b> 	<p>The alarm icon is shown when the unit encounters an issue that needs attention. Alarm codes are explained on the following page. All temperature-related alarms are blocked for the first 10 hours after the unit is plugged in to allow the system to stabilize and acclimate to the new environment.</p>

## ALARM CODES

Code	Cause	Solution
<b>The following alarm codes will be displayed on the screen along with the alarm icon. </b>		
<b>E1</b>	Bottle probe is not connected	Attach bottle probe to circular connector
	Faulty bottle probe connection	Locate faulty bottle probe connection by inspecting all wiring connections between the bottle probe and the circuit board. The two-pin connector for the bottle probe should be connected to the CPB/PB1 terminal on the circuit board. If it is not connected, plug it in. If a faulty connection has been identified, correct the issue or contact customer service for further assistance.  <b>NOTE:</b> The E1 code will not appear in the alarms menu. It will be permanently displayed on the screen.
	Defective bottle probe	Replace the bottle probe
<b>E2</b>	Faulty evaporator probe connection	Locate faulty evaporator probe connection by inspecting evaporator probe wire. The two-pin connector for the evaporator probe should be connected to the CPB/PB2 terminal on the circuit board. If it is not connected, plug it in.
	Defective evaporator probe	Replace the evaporator probe
<b>E7</b>	No communication between keypad and circuit board for 60 seconds	Verify that the display cable is connected to the keypad and the circuit board and is not damaged, frayed, or kinked. If problem persists, contact Customer Service for troubleshooting information.
<b>E10</b>	Clock battery is dead	Replace battery  <b>NOTE:</b> A dead clock battery will not affect the operation of your cooling unit.
<b>The following alarm codes will not be displayed on the home screen. However, the alarm icon will be displayed in the event of an alarm. The alarms can be viewed in the Set Menu's ALr folder. </b>		
<b>EA</b>	Unit is not draining properly	1. Check to see that the unit is level; if not, level it 2. Verify that the drain line is not clogged; if so, clear obstruction 3. Ensure that the condensate pump is operating  <b>NOTE:</b> If the drain line is obstructed or the pump fails for some reason, and the water level in the drip tray gets too high, the unit will not operate until the water in the internal drip tray drops back below the proper level.
<b>AH1</b>	The bottle probe is sensing a temperature that is 8°F above the setpoint	1. Allow time for the wine to reach the desired temperature 2. Ensure that the cellar is sealed properly 3. Verify that the bottle probe is calibrated correctly (refer to the User Menu on the following page) 4. Verify that the unit is sized correctly for the cellar
<b>AL1</b>	The bottle probe is sensing a temperature that is 8°F below the setpoint	1. Make sure the unit is not in cooling mode (the snowflake icon will not be illuminated) 2. Add heat to the room until the wine reaches the desired temp 3. Verify that the bottle probe is calibrated correctly (refer to the User Menu on the following page)
<b>Ad2</b>	The Anti-Frost Cycle ended on time-out	1. Check the evaporator coil for ice buildup. Unplug the unit and allow the coil to thaw before restarting. 2. Make sure the room to which the unit is exhausting is not below 60°F 3. If the unit repeatedly goes into Anti-Frost Cycles (one per minute), call Customer Service for more troubleshooting information



## USER MENU

The User Menu is accessed by **pressing and holding the SET button for 3 seconds**. Use the UP and DOWN ARROW buttons to navigate to desired parameters. Press the SET button again to view these parameters. Press the UP and DOWN ARROW buttons to adjust a parameter.

The following parameters are available in the menu:

Parameter	Description
<b>Fdc - humidity enhancement</b>	This parameter is measured in minutes, and is preset at the factory to 1. An increase in this parameter will increase the humidity enhancement of your cellar. This parameter should not be adjusted to zero. Adjustments should be made in increments of 5, with a maximum of 15 and a minimum of 1. After making any adjustments to humidity enhancement, <b>you should wait a minimum of 3 days</b> before making any additional adjustments. This will allow sufficient time for the cellar to acclimate to the new setting.
<b>FOF - "fan off"</b>	This setting controls how long the fan stays off after the setpoint has been reached. It is preset to 15 minutes. This setting should not be adjusted, as most properly constructed wine cellars retain an ample amount of humidity during the "fan off" cycle. If, however, you wish to decrease the duration of the "fan off" cycle (in order to increase the wine cellar's relative humidity), you can adjust this setting in the User Menu.
<b>Fon - "fan on"</b>	The "fan on" time is preset to zero minutes. This keeps the relative humidity of the wine cellar at a stable level. If, however, you wish to raise the relative humidity of your wine cellar, you can increase the duration of the "fan on" cycle in increments of five (5, 10, or 15 minutes). After making any adjustment to the "fan on" cycle, <b>you should wait a minimum of 3 days</b> before making any additional adjustments. This will allow sufficient time for the cellar to acclimate to the new setting.
<b>CA1 - bottle probe (Pb1) calibration</b>	<b>CA1 - bottle probe (Pb1) calibration:</b> You may use this parameter to calibrate the bottle probe to a known temperature. This parameter can be adjusted between -12°F and 12°F. For example, if the bottle probe temperature is 58°F, and the known temperature is 55°F, you can set the CA1 parameter to -3°F to match the known temperature.
<b>PA2 - installer menu</b>	This menu is only accessible using a password and is not available for adjustment.
<b>dOA - digital input</b>	This setting determines which of the unit's components will be activated or deactivated when a certain electrical relay is activated or deactivated in response to an alarm. The controller comes pre-programmed with a factory setting of 2.  2 = activates the compressor and fans 5 = disables the compressor and fans  <b>NOTE:</b> Setting the dOA to any number other than 2 or 5 will prevent the unit from operating properly.

# Emerson<sup>™</sup> Electronic Unit Controller

## Quick setup and troubleshooting guide

### Adjusting Low Pressure Settings

- Hold DOWN and SET simultaneously for 3 seconds to enter menu (PSI light will flash) ▼ + SET
- Cycle through menu options – UP/DOWN ▲ ▼
- Select function – SET SET
- Adjust value – UP/DOWN ▲ ▼
- Store function - SET SET
- Exit menu - UP and SET ▲ + SET

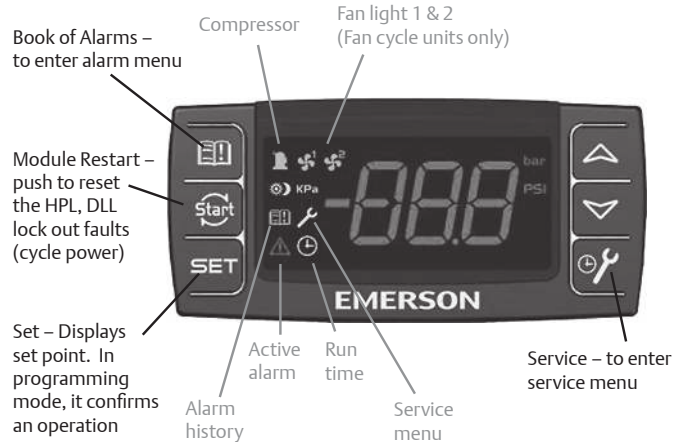

When light is on, feature or component is on or active

### Accessing Alarm Code Information

- Press and release ALARM 📖
- Cycle through menu options – UP/DOWN ▲ ▼
- Press SET to see number of alarms SET
- Press SET again to return to menu options SET
- Exit menu - UP and SET ▲ + SET

### Accessing Service Menu

- Hold SERVICE for 3 seconds 🔧
- Cycle through menu options – UP/DOWN ▲ ▼
- Press SET to see number of alarms SET
- Press SET again to return to menu options SET
- Exit menu - UP and SET ▲ + SET

Alarm	Description
PoF	Keypad locked
Pon	Keypad unlocked
P1	Suction probe failure
P2	Condenser probe failure
P3	DLT probe failure
HA	High condenser temperature alarm
dLt	DLT temperature alarm
dLL	DLT lock alarm
HP	High pressure trip alarm
HPL	High pressure trip lock-out alarm
EE	Module Failure
LOC	Number of lock-outs

Code	Description
StH	CompressorStarts -1000 -999999
StL	Compressor Starts -0 -999
CHH	CompressorHours -1000 -999999
CHL	Compressor Hours -0 -999
F1H	Fan 1 Hours -1000 -999999
F1L	Fan 1 Hours-0 -999
F2H	Fan 2 Hours -1000 -999999
F2L	Fand 2 Hours -0 -999

Example: If StH=12 and StL=500, the total number of compressor starts=12,500

Note: After 15 seconds of inactivity the controller will revert to the default display.

For more information visit [EmersonClimate.com/ElectronicUnitController](http://EmersonClimate.com/ElectronicUnitController) or call 1-888-367-9950

Display	Likely Causes	Other Possible Causes
Controller display remains blank after applying power	<ul style="list-style-type: none"> <li>Unit power not properly applied - check for proper applied voltage</li> <li>Power cable harness not plugged in properly or securely into the back of the controller – check connections</li> </ul>	<ul style="list-style-type: none"> <li>Power cable miswired – inspect cable, replace if needed</li> <li>Electrical assembly miswired – trace wiring diagrams</li> </ul>
Controller displays correctly, but the green compressor light is off and the compressor is not running	<ul style="list-style-type: none"> <li>Jumper cable not plugged in properly or securely into the back of the controller – check connections</li> <li>Controller is currently above the cut-in setting – check cut-in and cut-out settings</li> </ul>	<ul style="list-style-type: none"> <li>Jumper cable miswired – inspect cable, replace if needed</li> </ul>
Controller displays correctly and the green compressor light is on and the compressor is not running	<ul style="list-style-type: none"> <li>Power cable harness not plugged in properly or securely into the back of the controller – check connections</li> </ul>	<ul style="list-style-type: none"> <li>Power cable not wired to the contactor or compressor correctly, check wiring</li> <li>Power cable miswired – inspect cable, replace if needed</li> </ul>
Controller flashes “135” or “P1”	<ul style="list-style-type: none"> <li>Current system pressure is above 135 PSIG – wait for system to pull down</li> <li>Green harness not plugged in properly or securely into the back of the controller – check connections</li> <li>Cable not connected properly with the pressure transducer – check connections</li> </ul>	<ul style="list-style-type: none"> <li>Transducer cable miswired – inspect cable, replace if needed</li> <li>Damaged transducer – inspect transducer, replace if needed</li> </ul>
Controller flashes “P2” on a unit with fan cycling	<ul style="list-style-type: none"> <li>Green harness not plugged in properly or securely into the back of the controller – check connections</li> </ul>	<ul style="list-style-type: none"> <li>Transducer cable miswired – inspect cable, replace if needed</li> <li>Check condenser temperature sensor resistance values against table in AE-1376, Section 8</li> </ul>
Controller flashes “P2” on a unit without fan cycling after replacing a controller	<ul style="list-style-type: none"> <li>Controller not programmed properly – check parameters in the advanced menu</li> </ul>	
Controller flashes “P3” on a unit with DLT	<ul style="list-style-type: none"> <li>Jumper cable not plugged in properly or securely into the back of the controller – check connections</li> </ul>	<ul style="list-style-type: none"> <li>Jumper cable miswired – inspect cable, replace if needed</li> <li>Faulty DLT temperature sensor – check the discharge line temperature sensor resistance values against table in AE-1376, Section 8</li> </ul>
Controller flashes “P3” on a unit without DLT after replacing a controller	<ul style="list-style-type: none"> <li>Controller not programmed properly – check parameters in the advanced menu</li> </ul>	
Fans not running on a fan cycling unit and the fan lights are not on	<ul style="list-style-type: none"> <li>Condensing temperature is currently below the fan cut-in</li> <li>Condensing temperature sensor not properly installed – check installation</li> </ul>	<ul style="list-style-type: none"> <li>Transducer cable miswired – inspect cable, replace if needed</li> <li>Faulty temperature sensor - check condenser temperature sensor resistance values against table in AE-1376, Section 8</li> </ul>
Fans not running on a fan cycling unit and the fan lights are on	<ul style="list-style-type: none"> <li>Power cable harness not plugged in properly or securely into the back of the controller – check connections</li> </ul>	<ul style="list-style-type: none"> <li>Power cable miswired – inspect cable, replace if needed</li> <li>Electrical assembly miswired – trace wiring diagrams</li> </ul>
Controller flashes “HP” at power-up	<ul style="list-style-type: none"> <li>Jumper cable not plugged in properly or securely into the back of the controller – check connections</li> <li>High pressure switch is seeing above the cut-out pressure</li> <li>For a replacing an -00 controller, ensure that the jumper cable is the latest revision. It should have a blue wire in the harness. See replacement instructions for more details</li> </ul>	<ul style="list-style-type: none"> <li>Jumper cable miswired – inspect cable, replace if needed</li> <li>Faulty fixed Hp switch – inspect switch, replace if needed</li> </ul>
Controller flashes “HP” or “HPL”	<ul style="list-style-type: none"> <li>System operation causing high discharge pressures, check system operations</li> </ul>	<ul style="list-style-type: none"> <li>Bad high pressure switch, verify system pressure when the pressure switch trips.</li> <li>See AE-1376, Section 7.2 for more details</li> </ul>
Controller flashes “DLT” or “DLL”	<ul style="list-style-type: none"> <li>System operation causing high discharge line temperatures, check system operations</li> </ul>	<ul style="list-style-type: none"> <li>Faulty temperature sensor - check DLT sensor values against table in section 8</li> <li>See AE-1376, Section 7.1 for more details</li> </ul>
Controller flashing “HPL” or “DLL”	<ul style="list-style-type: none"> <li>System operation causing high discharge pressures (HPL) or high discharge line temperatures (DLL) repeatedly, check system operations</li> <li>To clear an “HPL” or “DLL” lockout, you can hold the Restart button for 3 seconds twice, or cycle power to the unit. If using the reset button, the alarm condition will have to clear (DLT temperature drops or Hp switch resets), and any minimum off time will need to complete (5 minutes for the fixed Hp switch)</li> </ul>	

[EmersonClimate.com/ElectronicUnitController](http://EmersonClimate.com/ElectronicUnitController)

2013ECT-46 (9/13) Emerson is a trademark of Emerson Electric Co. ©2013 Emerson Climate Technologies, Inc. All rights reserved.

**EMERSON. CONSIDER IT SOLVED.™**

## WHISPERKOOL TROUBLESHOOTING GUIDE

<b>Ice forming on the evaporator units</b>	
<b>Possible cause</b>	<b>Solution</b>
Evaporator filters or coils are dirty	Remove the filters and wash them, then clean the coils with a vacuum. If coils are very dirty, use a spray bottle with a small amount of liquid dish detergent or coil cleaner. Spray coils, let set for five minutes, then flush with fresh water.
There is something blocking the supply and/or return air	Remove blockage
The evaporator fans are not turning on	Call a service tech to troubleshoot
The evaporator units have not gone through an Anti-Frost Cycle yet	Check the coils for surface ice. Melt with blow drier until coils are warm to the touch. Soak up water with a towel.
If evaporator units continue to ice	Observe ice formation pattern. If only part way up the coil face, the system could be low on refrigerant. If all the way up, the coils may be dirty or airflow is blocked.
<b>System does not run/power up</b>	
<b>Possible cause</b>	<b>Solution</b>
Evaporator units are not plugged in	Make sure the units are plugged into an outlet
Power switch not on	Turn unit on by pressing the power button on the control
Line voltage rating is incorrect for the system	Check line voltage to make sure there is 110V-120V
Bottle at setpoint	Lower setpoint
Thermostat not calling for cooling	Lower setpoint
Faulty thermostat or wiring	Contact WhisperKool customer service
<b>Cellar temperature is too warm</b>	
<b>Possible cause</b>	<b>Solution</b>
The temperature of the room to which the condensing unit exhausts exceeds 110°F	Intake temperature needs to drop below 110°F
The system is undersized for the cellar	Order correctly sized system
There is something blocking the supply and/or return air on the evaporator units or the condensing unit	Remove airflow obstruction
Evaporator units are mounted too low in the cellar	Relocate units so the distance from the ceiling and top of the unit is no more than 18"
One or more of the fans is not turning on	Please contact the installing technician to troubleshoot
Compressor is not turning on	Please contact the installing technician to troubleshoot
Compressor keeps cycling on overload	Make sure all fans are working and there is no airflow obstruction
Poor seal around door or other areas requiring a seal (around the unit, wall joints, etc.)	Make sure there are no air gaps around the door. If door seal is damaged, replace it.
Setpoint too high	Lower the setpoint
Evaporator coils are frosted or iced up	Observe ice formation pattern. If only part way up the coil face, the system could be low on refrigerant. If so, contact your installing technician to assist with troubleshooting.
<b>System runs constantly</b>	
<b>Possible cause</b>	<b>Solution</b>
Leaky door seal or poorly insulated cellar	Fix leaky door seal and insulate cellar

<b>Units leak water</b>	
<b>Possible cause</b>	<b>Solution</b>
Evaporator units are not level	Evaporator units should be level on the wall to prevent leaking
Drain lines are clogged or kinked	Check drain lines to make sure water can flow freely
Drains are clogged, preventing water from escaping	Disconnect drain lines and clear them out; check drains for blockage
Drain lines do not have a downward slope	Fix drain lines so there is a downward slope from the unit to the drains
Coils are iced, causing drain pans to freeze and water to overflow	Melt ice with blow drier. Soak up water with a towel.
<b>System runs but does not cool</b>	
<b>Possible cause</b>	<b>Solution</b>
Lack of airflow	Make sure fans are unobstructed and that the evaporator filter, evaporator coil, and condenser coil are clean and free of debris
System undersized	Contact WhisperKool customer service
Compressor is overheating	Shut system off for 1 hour to allow compressor to cool. Turn back on and check for cooler air flow out. If compressor runs, check for and clean condenser coil as possible cause of compressor overheating. If problem repeats, contact your installing technician to assist with troubleshooting.
<b>Evaporator fans run but compressor does not</b>	
<b>Possible cause</b>	<b>Solution</b>
Running an Anti-Frost Cycle	1) If the system is maintaining the correct cellar temperature and there is a dripping snowflake symbol illuminated on the control, the system is going through an Anti-Frost Cycle. No action is required. 2) If the system is not maintaining the correct cellar temperature, this may be due to dirty evaporator filters or coils. 3) Call installing technician to troubleshoot, as the system may be low on charge or require an adjustment to the TXV.
Compressor and/or starting components faulty	Please contact the installing technician to troubleshoot
System may be performing the WHM function	Allow cooling system to revert back to cooling mode
Compressor may have overheated	Shut system off for 1 hour to allow compressor to cool. Turn back on and check for cooler air flow out. If compressor runs, check for and clean condenser coil as possible cause of compressor overheating. If problem repeats, contact your installing technician to assist with troubleshooting.
<b>Compressor runs but evaporator fan does not</b>	
<b>Possible cause</b>	<b>Solution</b>
Faulty fan motor	Please contact the installing technician to troubleshoot
Faulty controller	Please contact the installing technician to troubleshoot
<b>Compressor short cycles</b>	
<b>Possible cause</b>	<b>Solution</b>
Evaporator units blow on bottle probe	Move bottle probe to a more central location
System low on refrigerant charge	Please contact the installing technician to troubleshoot
Condensing fan motor/capacitor faulty	Please contact the installing technician to troubleshoot
Compressor and /or starting components faulty	Please contact the installing technician to troubleshoot
<b>Humidity in cellar too low</b>	
<b>Possible cause</b>	<b>Solution</b>
Not enough moisture	Purchase and place a humidifier (or a decorative fountain) in cellar

## MAINTENANCE SCHEDULE

<b>Monthly</b>	<ol style="list-style-type: none"><li>1. Check coils</li><li>2. Check for unusual noise or vibration</li><li>3. Check the drain lines to see if they are above the waterline (if draining into a vessel)</li></ol>
<b>Quarterly</b>	<ol style="list-style-type: none"><li>1. Use a vacuum with brush attachment to clean coils; be careful not to crush coil fins when cleaning</li><li>2. Change duct filters if the system is ducted</li></ol>
<b>Annually</b>	<ol style="list-style-type: none"><li>1. Inspect for corrosion</li><li>2. Check wiring connections and integrity of cords</li><li>3. Pour a 50/50 bleach solution into the drain lines every spring</li></ol>

# TECHNICAL ASSISTANCE

WhisperKOOL Customer Service is available Monday through Friday from 6:00 a.m. to 4:00 p.m. Pacific Standard Time.

The appointed customer service representative will be able to assist you with your questions and warranty information more effectively if you provide them with the following:

- The model and serial number of your WhisperKOOL system(s).
- Location of unit and installation details, such as ventilation, ducting, construction of your wine cellar, and room size.
- Photos of the cellar and installation location may be needed.

## Contact WhisperKOOL Customer Service

1738 E. Alpine Ave  
Stockton, CA, 95205  
[www.whisperkool.com](http://www.whisperkool.com)

**Email:** [support@whisperkool.com](mailto:support@whisperkool.com)  
**Fax:** 209-466-4606

Visit [www.emersonclimate.com/electronicunitcontroller](http://www.emersonclimate.com/electronicunitcontroller) for online brochures, bulletins, instruction videos, and general product information.

**Download the Copeland Mobile App on your mobile device for additional troubleshooting and technical information.**



## ACCESSORIES FOR COOLING UNITS

WhisperKOOL offers accessories to enhance and customize your wine cooling unit:

### UV Air Purification Upgrade

The optional UV air purification kit provides chemical-free cleaning of the air from germs and microbes, inhibits the growth of mold and bacteria inside the cooling system, and optimizes system performance and longevity.

### Condensate Pump Kit

The condensate pump kit automatically removes water that drips out of the evaporator unit's drain line. The pump is controlled by a float/switch mechanism that turns the pump on when approximately 2¼" of water collects in the tank, and automatically switches off when the tank drains to approximately 1¼". The condensate pump kit allows the excess condensate to be pumped up to 20 feet away from the unit.

### Exterior Housing

If the cooling unit is installed outside, it will need protection from sun, wind, and rain. The exterior housing protects the condensing unit portion of the split system from the elements when installed outdoors.

**Accessories can be purchased at [www.whisperkool.com](http://www.whisperkool.com)**

**WhisperKOOL Product Terms and Conditions**  
**Including Product Limited Warranty And Product Installation Requirements**  
**For WhisperKOOL Split System Series**

ATTENTION: PLEASE READ THESE TERMS OF USE CAREFULLY BEFORE INSTALLING YOUR WHISPERKOOL COOLING SYSTEM. INSTALLING YOUR WHISPERKOOL COOLING SYSTEM INDICATES THAT YOU ACCEPT AND AGREE TO EACH OF THE TERMS AND CONDITIONS SET FORTH HEREIN ("TERMS OF USE"). IF YOU DO NOT ACCEPT THESE TERMS OF USE, YOU RISK VOIDING YOUR WARRANTY AND ASSUMING ADDITIONAL REPAIR AND REPLACEMENT COSTS.

**1. Purchase of a WhisperKOOL Cooling System assumes that the Purchaser ("End User") fully accepts and agrees to the Terms and Conditions set forth in this document. The Terms and Conditions of Sale and Owner's Manual are shipped with each unit and, if another copy is needed, replacement copies can be downloaded from the company website (whisperkool.com) or by contacting WhisperKOOL directly for a new copy. WhisperKOOL reserves the right, in its sole discretion, to change its Terms and Conditions at any time, for any reason, without notice.**

**2. WhisperKOOL Product Installation and Limited Warranty**

- A. Purchaser of the product must arrange for the product to be installed by a certified HVAC/R technician in accordance with procedures set forth by WhisperKOOL and described in the WhisperKOOL Owner's Manual.
- B. The HVAC/R technician installing the product must complete the designated portion of the Split Startup Checklist and provide licensing or certification identification number information to assist in the warranty registration process.
- C. Purchaser must return the completed Split Startup Checklist to WhisperKOOL within thirty (30) days of installation of Product. The Split Startup Checklist must be approved by WhisperKOOL to activate the Limited Warranty. If the Split Startup Checklist is approved, Purchaser will be sent activation approval documents and will start receiving the benefits of the Limited Warranty throughout the warranty period. If the Split Startup Checklist is incomplete, Purchaser will be informed they have five days to complete the Split Startup Checklist and re-submit to WhisperKOOL. The Split Startup Checklist will be reviewed again, and if denied, Purchaser will be informed that they have 10 business days for corrective action. Failure to register the Product may result in loss of warranty.
- D. Purchaser is responsible for the full costs of installation and any additional parts required for the proper and complete installation of the product.
- E. For Split Systems returned to WhisperKOOL in accordance with the terms and conditions of the Limited Warranty, WhisperKOOL warrants against defects in material and workmanship as follows:
  1. **LABOR** — For a period of two (2) years commencing on the date of purchase, WhisperKOOL will, at its option and discretion, reimburse up to \$250 to the End User for cost incurred for servicing, repairing, removing or installing warranty parts. Invoice for service must be forwarded to WhisperKOOL for assessment and processing. The Split System warranty is invalid if there is attempted repair by anyone other than an HVAC/R technician approved by WhisperKOOL to service the Product.
  2. **PARTS** — For a period of two (2) years commencing on the date of purchase, WhisperKOOL will supply, at no charge, new or rebuilt replacement parts in exchange for defective parts. Replacement parts are warranted only for the remainder of the original warranty period.
  3. **FREIGHT** — For a period of two (2) years commencing on the date of purchase, if after WhisperKOOL approved evaluation the original Product failure is determined to be the cause of a manufacturers defect, and not the cause of an installation error or other cause, WhisperKOOL will cover at its option, freight for the replacement parts or Product.

**The following part or cause of failure is not the responsibility of WhisperKOOL:**

- Improper voltage supply
- Line set with screw connectors (high end and low end)
- Leaks found at the braze points when performing pressure check
- Unit that has been charged incorrectly



- Incorrect tubing diameter used on line set
- A unit that has been wired incorrectly
- Valve stem on condenser side
- Improper installation of P-Trap
- Lack of P-Trap (if required)
- Condensers that are installed outdoors or in elements that would affect operation without proper cover or housing. (Housing is available from Manufacturer).

**Product Warranty Limitations and Exclusions.**

1. This limited warranty does not cover cosmetic damage caused during installation, damage due to acts of God, commercial use, accident, misuse, abuse, negligence, or modification to any part of the Product. Delivery and installation of the Product, any additional parts required, as well as removal of the Product if warranty work is required, are all at the sole cost, risk and obligation of the End User.
2. This limited warranty does not cover damage due to improper installation or operation or lack of proper maintenance of the Product, connection of the Product to improper voltage supply, or attempted repair of the Product by anyone other than a technician approved by WhisperKOOL to service the Product.
3. This limited warranty does not cover any Product sold "AS IS" or "WITH ALL FAULTS."
4. Product that has been replaced during warranty period does not extend the warranty period past the original date of purchase.
5. This limited warranty is valid only in the continental United States. Sales elsewhere are excluded from this warranty.
6. Proof of purchase of the Product in the form of a bill of sale, receipted invoice or serial number, which is evidence that the Product is within the Limited Warranty Period, must be presented by the End User to WhisperKOOL in order to obtain limited warranty service.
7. This limited warranty is void if the factory applied serial number has been altered or removed from the Product.
8. This limited warranty is voided if installed in an enclosure of insufficient design that does not follow the Product installation requirements stated herein and in the owner's manual.
9. Removing the rivets from the Product's unit housing without prior authorization from WhisperKOOL voids this limited warranty.
10. The End User must first contact WhisperKOOL Customer Service prior to attempting service on any Product still under the limited warranty; else the limited warranty is voided.
11. This limited warranty does not cover Product being concealed by, but not limited to, vegetation, fabric, shelving, mud, snow, or dirt. Product must not be painted or limited warranty will be void.
12. This limited warranty does not cover exposure to corroding environments such as, but not limited to, petroleum and gasoline products, cleaning solvents, caustic pool chemicals, and marine air.
13. This limited warranty does not cover any cause not relating to Product defect.
14. THE REPAIR OR REPLACEMENT OF THE PRODUCT AS PROVIDED UNDER THIS LIMITED WARRANTY IS THE EXCLUSIVE REMEDY OF YOU, THE END USER, AS WELL AS ANYONE ELSE IN THE CHAIN OF TITLE OF THE PRODUCT, DOES NOT START A NEW LIMITED WARRANTY TIME PERIOD, AND IS IN LIEU OF ALL OTHER WARRANTIES (EXPRESS OR IMPLIED) WITH REGARD TO THE PRODUCT. IN NO EVENT SHALL WHISPERKOOL BE LIABLE FOR INCIDENTAL, CONSEQUENTIAL, SPECIAL OR CONTINGENT DAMAGES FOR BREACH OF ANY EXPRESS OR IMPLIED WARRANTY ON THIS PRODUCT. THE IMPLIED WARRANTIES OF MERCHANTABILITY
15. AND FITNESS FOR A PARTICULAR PURPOSE ARE HEREBY EXPRESSLY DISCLAIMED. Some states do not allow the exclusion or limitation of incidental or consequential damages, or allow limitations on how long an implied warranty lasts, so the above limitations or exclusions may not apply to you. This limited warranty gives you specific legal rights, and you may have other rights, which vary from state to state.
16. Failure of the End User to comply with all of the Product Installation Requirements, Maintenance Requirements and End User Requirements may, at WhisperKOOL's sole discretion, void this limited warranty.
17. No one has any authority to add to or vary the limited warranty on this Product.

### 3. Maintenance Requirements

The End User is responsible for checking the coils on the condenser unit and vacuuming them every three months to maintain them free of debris. It is the End User's responsibility to clean off any accumulated dust, lint, or other debris from the front and rear intake grills; failure to do this on a regular basis will restrict the airflow and may affect the Product's ability to function properly. Periodically cleaning the Product's vents will help assure maximum cooling efficiency. The drain tube must also be checked and kept clean and free of debris and mold to maintain proper performance.

Mold is a natural living organism in the environment. It exists in the air in the form of microscopic spores that move in and out of buildings through doors, windows, vents, HVAC systems and anywhere else that air enters. Once it is discovered, mold must be addressed quickly and appropriately. Delayed or improper treatment of mold issues can result in costly and reoccurring repairs. If the End User suspects a mold problem, it is always best to hire a qualified and experienced mold remediation specialist.

### 4. Additional End User Costs And Responsibilities

#### Terms and conditions for replacing the Product that is being evaluated for limited warranty.

1. After evaluation by a certified HVAC/R technician and the Product is found to be irreparable in the field, contact WhisperKOOL Customer Service to arrange for replacement under the warranty guidelines. When a claim for warranty is submitted for a condenser skid, the End User must purchase a new condenser skid from WhisperKOOL at retail price. Upon installation of the new condenser skid by a certified HVAC/R Technician, the HVAC/R Technician must complete the Installation Checklist and End User must submit the Installation Checklist to WhisperKOOL Customer Service for approval. The original condenser skid must be returned within 21 days to WhisperKOOL for failure analysis. If the Installation Checklist is approved and the failure is evaluated as defective and not installation error or other reason, the End User will be refunded for the cost of the replacement skid.
2. If the Product failure is evaluated and it is determined that it is an installation error or other reason, all costs, including shipping will be the responsibility of the End User.

The following items are not covered under any warranty and are the sole responsibility of the End User:

- A. End Users should satisfy themselves that the Product they are purchasing is suitable for their particular needs and requirements, and thus no responsibility will be placed with WhisperKOOL for the End User's decisions in this regard.
- B. End Users must assure that the product is installed by a certified HVAC/R technician. Failure to do so will result in Voiding the Limited Warranty.
- C. It is the End User's responsibility to secure safe haven/storage for ANY AND ALL items that are being kept and stored in the End User's wine cellar, including any Product. WhisperKOOL takes no responsibility for the safety and preservation of the aforementioned items in the event that the environment becomes unsuitable to maintain a proper storage environment.
- D. End User is responsible for initial installation costs, including, but not limited to, labor costs and the cost of any additional parts necessary to complete the installation.
- E. End User is responsible for all costs incurred for the installation and/or removal of the Product, or any part thereof, unless such cost has been agreed by WhisperKOOL to be a warranty repair prior to the work being performed.

### 5. Sales and Use Tax

WhisperKOOL only collects California sales tax for orders shipped within the State of California; WhisperKOOL does not collect sales tax for orders shipped to other states. However, the Purchaser and the End User may be liable to the taxing authority in their state for sales tax and/or use tax on the Product. The Purchaser and the End User should each check with their state's taxing authority for sales and use tax regulations.

### 6. Customer Service and Troubleshooting

WhisperKOOL's customer service department is available to answer any questions or inquiries for End Users regarding a WhisperKOOL Product, as well as to assist in performing basic troubleshooting, Monday through Friday, from 6:00 a.m. to 4:00 p.m. PST, support@WhisperKOOL.com. WhisperKOOL reserves the right to have a certified, WhisperKOOL-approved, HVAC/R technician go on site and inspect the product if the initial trouble shooting warrants further investigation.

WhisperKOOL Corporation is located at 1738 East Alpine Avenue, Stockton, California 95205.

## 7. Request for Product Evaluation and Repair Under Warranty

**SPLIT SYSTEM FIELD SERVICE WARRANTY POLICY:** This Policy is to clarify what falls under Warranty Service and what becomes the responsibility of the Owner. WhisperKOOL (“manufacturer”) strives to provide our customers with a superior Product and we back our Product with a Two Year Limited Warranty. Please review the WhisperKOOL Product Terms and Conditions including Product Limited Warranty and Product Installation Requirements to ensure you have a complete understanding of our Policy and coverage of your Split System.

**ARBITRATION:** Any disputes arising out of or in connection with the installation and warranty of the Split System shall be referred to and finally resolved by a WhisperKOOL approved Independent Certified HVAC/R Technician. The evaluation of the Technician on all issues or matters of identifying the responsible party (WhisperKOOL or Installing Technician) shall be determined in a written report. This report will be made available to all concerned parties. If discovered under warranty, WhisperKOOL will assume the financial responsibility under their warranty guidelines. If the report finds the Owner’s Installer as the responsible party, WhisperKOOL will provide all documentation to the customer to substantiate the findings. This will include the Invoice from the Independent Certified HVAC/R Technician and the written report of the findings. The Owner will become responsible for payment directly to WhisperKOOL for all charges incurred for repairs (labor, parts and shipping costs) on the Split System.

## 8. Miscellaneous Terms and Conditions

- A. Return Policy. All return inquiries must be made within thirty (30) calendar days of the original purchase of a Product and are subject to a twenty five percent (25%) restocking fee. Shipping costs are not refundable and the Purchaser is responsible for all return shipping costs (including customs fees and duties, if applicable).
- B. Security Interest. WhisperKOOL retains a security interest in each Product until payment in full.
- C. Construction and Severability. Every provision of these Terms and Conditions shall be construed, to the extent possible, so as to be valid and enforceable. If any provision of these Terms and Conditions is held by a court of competent jurisdiction to be invalid, illegal or otherwise unenforceable, such provision will, to the extent so held, be deemed severed from the contract of sale between Purchaser and WhisperKOOL, and all of the other non-severed provisions will remain in full force and effect.
- D. Governing Law/Choice of Forum. The laws of the State of California (without regard for conflicts of law) shall govern the construction and enforcement of the these Terms and Conditions of Sale (Sections 1 through 9 inclusive, including Product Limited Warranty And Product Installation Requirements), and further these Terms and Conditions of Sale shall be interpreted as through drafted jointly by WhisperKOOL and Purchaser. Any dispute will be resolved by the courts in and for the County of San Joaquin, State of California, and all parties, WhisperKOOL, Purchaser and End User, hereby irrevocably submit to the personal jurisdiction of such courts for that purpose. No waiver by WhisperKOOL of any breach or default of the contract of sale (including these Terms and Conditions of Sale) concerning a Product will be deemed to be a waiver of any preceding or subsequent breach or default.
- E. Correction of Errors and Inaccuracies. These Terms and Conditions may contain typographical errors or other errors or inaccuracies. WhisperKOOL reserves the right to correct any errors, inaccuracies or omissions, and to change or update these Terms and Conditions, at any time without prior notice.

## 9. Questions, Additional Information And Technical Assistance

- A. Questions. If you have any questions regarding these Terms and Conditions or wish to obtain additional information, contact us at [support@WhisperKOOL.com](mailto:support@WhisperKOOL.com) or please send a letter via U.S. Mail to:

Customer Service  
WhisperKOOL Corporation  
1738 E Alpine Ave  
Stockton, CA 95205

E-mail: [support@whisperkool.com](mailto:support@whisperkool.com)  
Web: [www.whisperkool.com](http://www.whisperkool.com)

- B. Technical Assistance. WhisperKOOL Customer Service is available Monday through Friday from 6:00 a.m. to 4:00 p.m. PST. The Customer Service representative will be able to assist you with your questions and warranty information more effectively if you provide them with the following:
  - 1. The model and serial number of your WhisperKOOL UNIT.
  - 2. The location of the system and installation details, such as ventilation, construction of your wine cellar, and room size.

**Model** \_\_\_\_\_ **Serial Number** \_\_\_\_\_

**Installed by** \_\_\_\_\_ **Date** \_\_\_\_\_

*Whisper***KOOL**<sup>™</sup>

WhisperKOOL  
1738 E. Alpine Ave  
Stockton, CA 95205  
[www.whisperkool.com](http://www.whisperkool.com)

***PLATINUM SPLIT TWIN***  
**VERSION 5**  
**TECHNICIAN'S MANUAL**

*Whisper***KOOL**<sup>TM</sup>  
The Coolest Thing In Wine Storage

**Conforms to ANSI/UL Std 427**

**Certified to CAN/CSA Std C22.2 No. 120**

***We manufacture, test and certify 100% of our wine cooling units in the USA. By sourcing the best components and closely controlling our manufacturing processes, we can assure the highest-quality, lowest defect manufacturing rates in the industry.***

Copyright © 2022. WhisperKOOL. All rights reserved.

WhisperKOOL copyrights this manual, the product design, and the design concepts, with all rights reserved. Your rights with regard to the hardware and manual are subject to the restrictions and limitations imposed by the copyright laws of the USA. Under copyright laws, this manual may not be copied, reproduced, translated, transmitted, or reduced to any printed or electronic medium or to any machine-readable form, for any purpose, in whole or in part, without the written consent of WhisperKOOL.

Every effort has been made to ensure that the information in this manual is accurate. WhisperKOOL is not responsible for printing or clerical errors.

WhisperKOOL reserves the right to make corrections or improvements to the information provided and to the related hardware at any time, without notice.

Vinothèque and WhisperKOOL are registered trademarks, and ECE is a trademark of WhisperKOOL. All rights reserved.

Mention of third-party products is for informational purposes only and constitutes neither an endorsement nor a recommendation. WhisperKOOL assumes no liability with regard to the performance or use of these products.

# TABLE OF CONTENTS

<b>Introduction</b> .....	2
<b>Quick Start Guide</b> .....	3
<b>Before You Start</b> .....	4
<b>Receiving &amp; Inspecting the System</b> .....	5
<b>Quick Reference Guide</b>	
Wall-Mounted Evaporator .....	6
Fully Ducted Evaporator .....	7
Wall-Mounted Twin Specifications .....	8
Fully Ducted Twin Specifications .....	9
Condensing Unit Quick Reference Guide .....	10
<b>Evaporator Installation</b>	
Items to Route before Installing the Evaporator Unit .....	12
Preparing the Wall-Mounted Evaporator Unit .....	13
Installing the Wall-Mounted Evaporator Unit .....	14
Preparing the Fully Ducted Evaporator Unit .....	16
Installing the Fully Ducted Evaporator Unit .....	17
<b>Ducting Overview</b> .....	18
<b>Drain Line</b> .....	20
<b>Liquid-Measuring Thermostat (Bottle Probe)</b> .....	21
<b>Remote Display Installation</b> .....	22
<b>Wiring Diagrams</b>	
Platinum Split Twin .....	28
Platinum Split Twin Master Evaporator .....	29
Platinum Split Twin Slave Evaporator .....	30
Platinum Split Twin 9000 Condensing Unit .....	31
Copeland Cold Weather Start Kit .....	32
<b>Preparing the Condensing Unit</b> .....	33
<b>Installing the Condensing Unit</b> .....	33
<b>Line Set Piping Diagram</b> .....	34
<b>Installing the Ducted Plenum</b> .....	37
<b>System Operation</b> .....	42
<b>Controller Functions</b> .....	44
<b>WhisperKOOL Troubleshooting Guide</b> .....	50
<b>Maintenance Schedule</b> .....	52
<b>Bypass Test Procedure</b> .....	54
<b>Technical Assistance &amp; Accessories</b> .....	55
<b>Installation Terms and Conditions</b> .....	56



## INTRODUCTION

### Customer Service

Thank you for purchasing a WhisperKOOL cooling system. We strive to provide the highest-quality products and the best possible customer service. If you have any questions about your system, please visit [WhisperKOOL.com](http://WhisperKOOL.com).

### Using the Manual

This manual is intended to assist in the proper maintenance of the cooling system. In order to ensure the longevity of your cooling unit, the equipment should be installed as outlined in the technician's manual. It is also vital to establish a proper care and maintenance schedule. Please read and review this manual carefully and keep it for future reference.

### What is the WhisperKOOL Cooling System?

The WhisperKOOL cooling system is a specialized refrigeration system designed for one purpose only: to maintain the optimal temperature and humidity levels conducive to the proper storage and aging of fine wines. This system produces minimal in-cellar noise and has the most lenient exhaust requirements. An exterior housing is required for outdoor condensing unit installations.

### How Does the Cooling System Work?

Similar to the air conditioning systems used for homes, the evaporator unit and condensing units are installed in separate locations and are connected by a refrigerant line set. The evaporator portion is commonly installed in the wine cellar, with the condensing unit is located either outside or in a remote indoor location that is ventilated. An exterior housing is required for outdoor condensing unit installations.

### Temperature Setting

The system is designed to maintain a cellar temperature of 55°F as long as the ambient temperature does not exceed 110°F.

## WARRANTY REGISTRATION

In order to activate the warranty of your system, the verification and operational documentation must be completed by the certified refrigeration technician installing your system and submitted via mail, fax, or e-mail.

Mail to:  
WhisperKOOL  
ATTN: Warranty Registration  
1738 E. Alpine Avenue  
Stockton, CA 95205-2505  
USA

Fax to:  
209-466-4606

Scan and email to:  
[warranty@whisperkool.com](mailto:warranty@whisperkool.com)

# QUICK START GUIDE\*

## Pump-down Cycle

WhisperKOOL's split systems operate on a pump-down cycle different from traditional air conditioners. As such, there is no wiring between the condensing unit and evaporator unit.

WhisperKOOL units utilize a solenoid valve on the liquid line and a low-pressure switch on the suction line. When the thermostat calls for cooling, the solenoid valve opens, permitting the flow of refrigerant. The low-pressure switch then signals the compressor to cycle on.

When the cellar reaches the desired temperature and the thermostat is satisfied, the solenoid will close, stopping the liquid refrigerant flow to the TXV valve. The compressor will continue to operate until most of the refrigerant on the low side boils off and is pumped through the compressor into the condenser coil and receiver. As the suction pressure falls below the pressure control setting, the low-pressure switch will signal the compressor to cycle off. Most of the refrigerant is now stored between the condensing unit and receiver.



**WARNING:** Do not utilize a ground fault interrupter, as it will prevent the unit from drawing the amperage necessary to start the unit.



## TXV Adjustments

- A TXV adjustment may be necessary based on ambient temperatures in the cellar and at the condensing unit.
- Adjust the TXV until the superheat measured at the suction line service valve is 20-30°F.
- Under normal operation, with the wine cellar at 55°F and the ambient temperature at 85°F, the low side pressure should be between 28-32 PSI and the high side should be between 160-180 PSI.

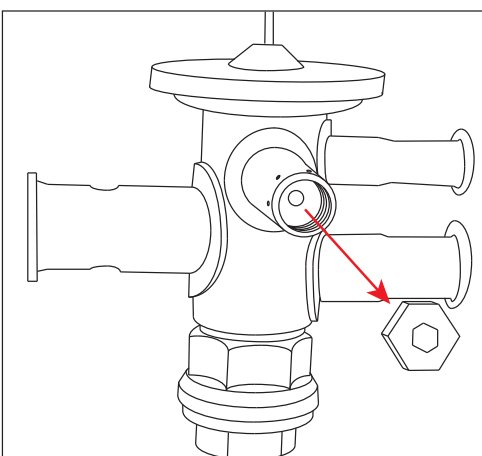
<p style="text-align: center;"><b>TXV</b></p> <p>The TXV is preadjusted at the factory. If the superheat is not within 20-30° at the service valve, the TXV will need to be adjusted.</p> <p style="text-align: center;"><b>ADJUSTING THE TXV</b></p> <p>Use a 5/32" hex key to remove the cap from the TXV superheat adjustment port. With the cap removed, insert the hex key into the superheat adjustment port. Increase superheat by turning the hex key clockwise. Decrease superheat by turning the hex key counterclockwise.</p>	
--	---

<p style="text-align: center;"><b>Liquid Line King Valve</b></p> <p style="text-align: center;">This location is used to charge the system with liquid refrigerant and identify the high side pressure of the system.</p> <p style="text-align: center;"><b>Calculating Subcooling</b></p> <p style="text-align: center;">To determine the subcooling of the system, calculate the difference between the <b>high side pressure of the system (converted to temperature)</b> and the <b>temperature of the liquid line</b>. The temperature of the liquid line will be taken at the outlet of the receiver.</p> <p style="text-align: center;">*Saturation temp — liquid line temp</p> <p style="text-align: center;"><b>4-6°F SUBCOOLING REQUIRED FOR WARRANTY APPROVAL</b></p>
--

\*Further system operation information is available on page 42.

## BEFORE YOU START

1. **Inspect all components prior to installation.** If damage is found, please contact your distributor or WhisperKOOL Customer Service at support@WhisperKOOL.com.
2. Each evaporator unit **requires a dedicated 115V, 15-amp circuit.** The condensing unit **requires a dedicated 230V single-phase 15-amp circuit.** Use a surge protector with the unit. **Do not use a GFI** (ground fault interrupter) line.
3. You are **REQUIRED** to **install a drain line** to remove condensation from each evaporator unit.
4. ***The warranty is not active until a warranty checklist has been received, reviewed, and approved.***
5. The system is intended **for use in properly designed and constructed wine cellars.** Hire a professional wine storage consultant with a valid contractor's license to build your wine cellar.
6. WhisperKOOL requires that all split systems be installed by a certified HVAC-R technician only. NATE or equivalent is recommended.
7. ***It is vital that the units be set apart and oriented so that the return air from one unit does not recirculate into the supply air of the other unit.***

If you encounter a problem with your WhisperKOOL system, please refer to the Troubleshooting Guide. If you have any further questions or concerns, or need assistance, please contact WhisperKOOL's Customer Service at support@WhisperKOOL.com. Please be sure all testing has been completed prior to contacting Customer Service. Please have your results ready for your representative.

# RECEIVING & INSPECTING THE SYSTEM

- Use caution when lifting and check package for damage.
- Lift only at the designated hand-hold locations on the shipping container, or fully support the unit from underneath. A shipment may include one or more boxes containing accessories.
- Before opening the container, inspect the packaging for any obvious signs of damage or mishandling.
- Write any discrepancy or visual damage on the bill of lading before signing.
- Allow the condensing unit to sit for 24 hours prior to start-up. The condensing unit can be placed in the installation location, piped, and evacuated during this time.

**NOTE:** WhisperKOOL units are manufactured in the USA and tested prior to shipment.

- Review the packing slip to verify contents.
- Check the model number to ensure it is correct.
- Check that all factory options ordered are listed.

**If any items listed on the packing slip do not match your order information, contact WhisperKOOL Customer Service immediately.**

**Check all shipped boxes for the following contents:**

### Master Evaporator Box

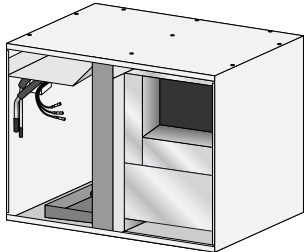

- (1) Master Platinum Split Twin evaporator unit
- (1) Wall-mounted evaporator installation template

#### Documentation bag (master):

- Platinum Split Twin owner's manual
- Platinum Split Twin technician's manual
- R-134a split system warranty checklist

#### Accessory kit bag (master):

- KDT Plus display cable (50 feet)
- KDT Plus wall mount bracket assembly
- KDT Plus flush mount bracket assembly
- KDT Plus display assembly
- Flush mount template
- Black strain relief bushing
- Evaporator installation hardware bag
- KDT Plus hardware bag

- (2) 1/2" x 1/2" 90° nylon barbed fitting
- (1) 1/2" barbed tee
- (1) Double-D strain relief
- (4) 3/4" adhesive cable tie mounts
- (2) Small cable ties
- (4) #8 x 1 3/4" hex-head screws

- (1) 1/16" OD grommet
- (2) 1/2" nylon hole plugs
- (4) #6 x 1" PHP zinc Type A screws
- (4) 8-10 x 7/8" blue plastic screw anchors

- (2) 1/2" x 1/2" 90° nylon barbed fitting
- (1) 1/2" barbed tee
- (1) Double-D strain relief
- (4) 3/4" adhesive cable tie mounts
- (2) Small cable ties
- (4) #8 x 1 3/4" hex-head screws

### Slave Evaporator Box

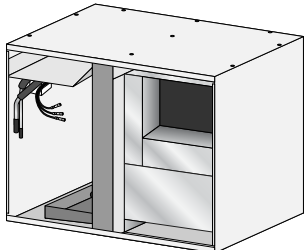

- (1) Slave Platinum Split Twin evaporator unit
- (1) Wall-mounted evaporator installation template
- (1) Evaporator installation hardware bag

#### Ducted Master Accessory Kit Box

- (1) Stainless steel bottle probe (50-ft cord)
- (1) Duct plenum

#### Wall-Mounted Master Accessory Kit Box

- (1) Retractable bottle probe
- (1) Filter grille

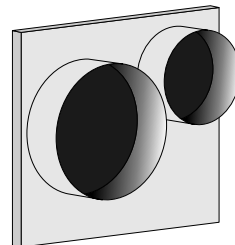

OR

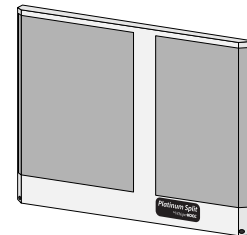

### Condensing Unit Box

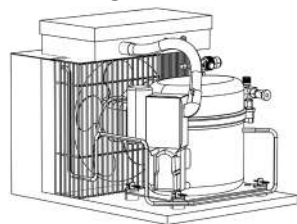

- (1) Condensing unit
- (1) Condensing unit accessory kit:
  - (1) 1/4" filter drier
  - (1) 1/4" sight glass

#### Ducted Slave Accessory Kit Box

- (1) Duct plenum

#### Wall-Mounted Slave Accessory Kit Box

- (1) Filter grille

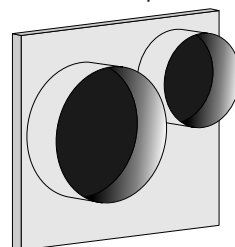

OR

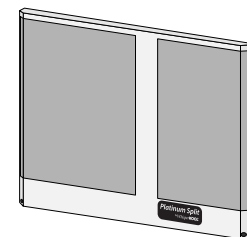

Please leave the unit in its original box until you are ready for installation. This will allow you to move the product safely without damaging it. When you are ready to remove the product from the box, refer to the installation instructions.

**TIP:** Save your box and all packaging materials. They provide the only safe means of transporting/shipping the unit.

## QUICK REFERENCE GUIDE

### Front / Side View

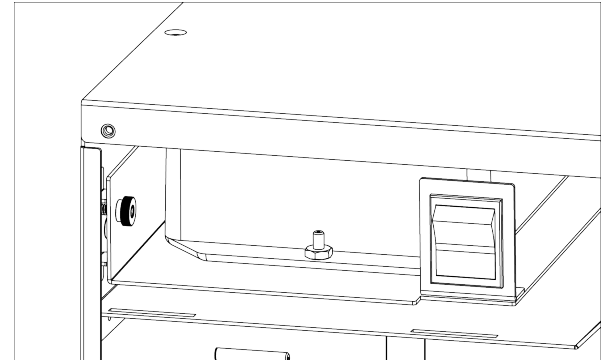
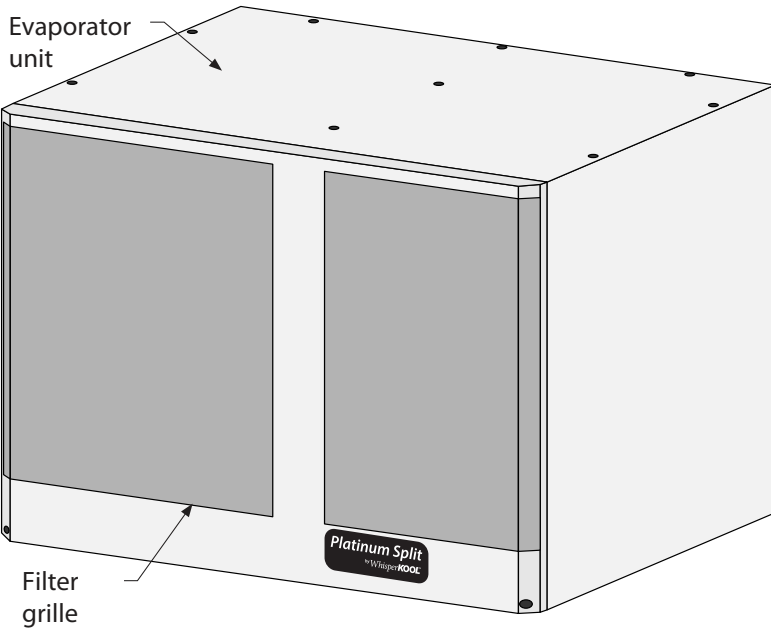

### Fan Speed Switch

The cooling system comes equipped with a variable fan speed switch. Increasing the fan speed increases the volume of cool air blown from the system. It is set by the factory to MED. To access the fan speed switch it is necessary to remove the front grille.

### Wall-Mounted — Rear / Side View

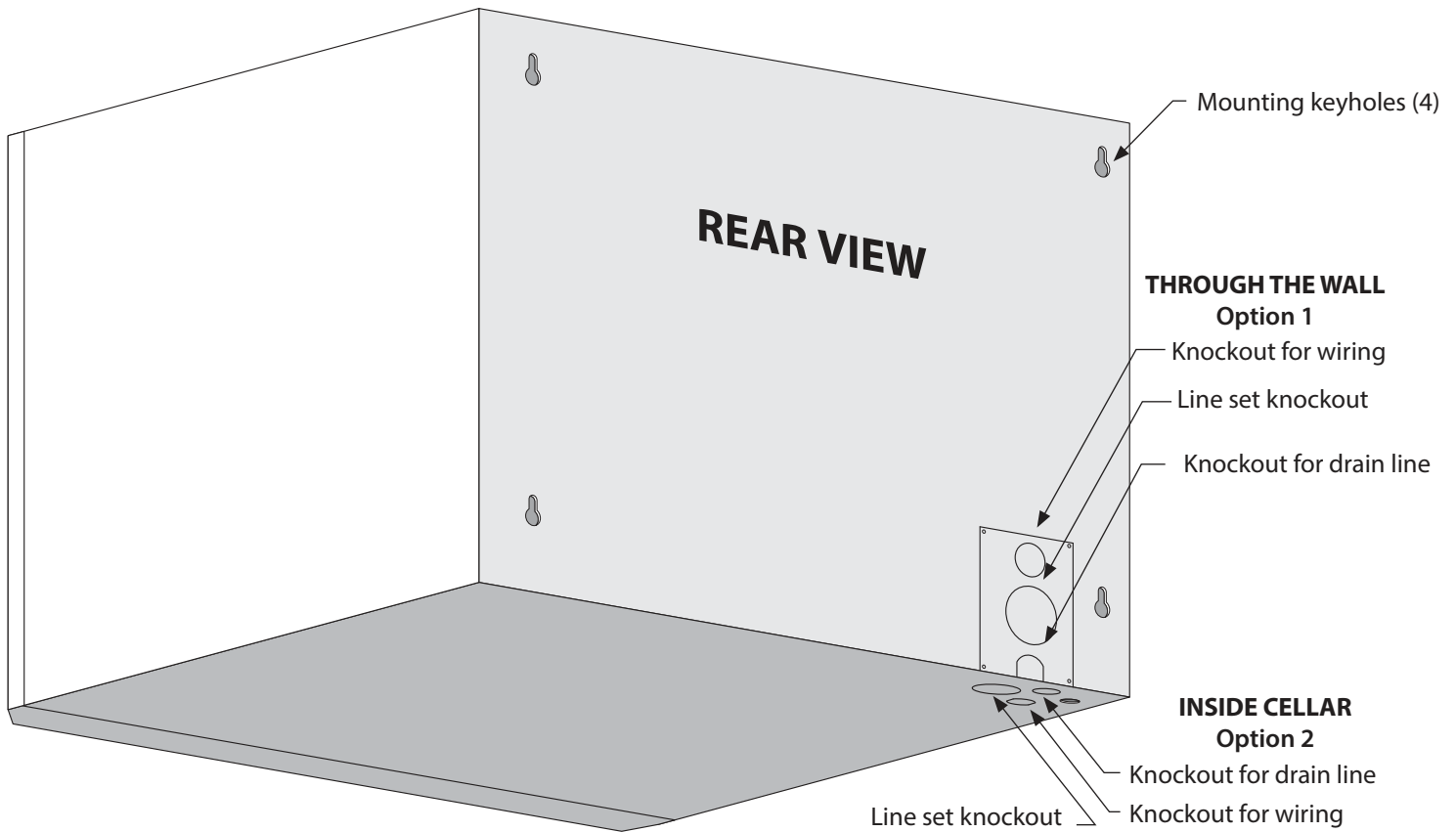

Fully Ducted — Front / Side View

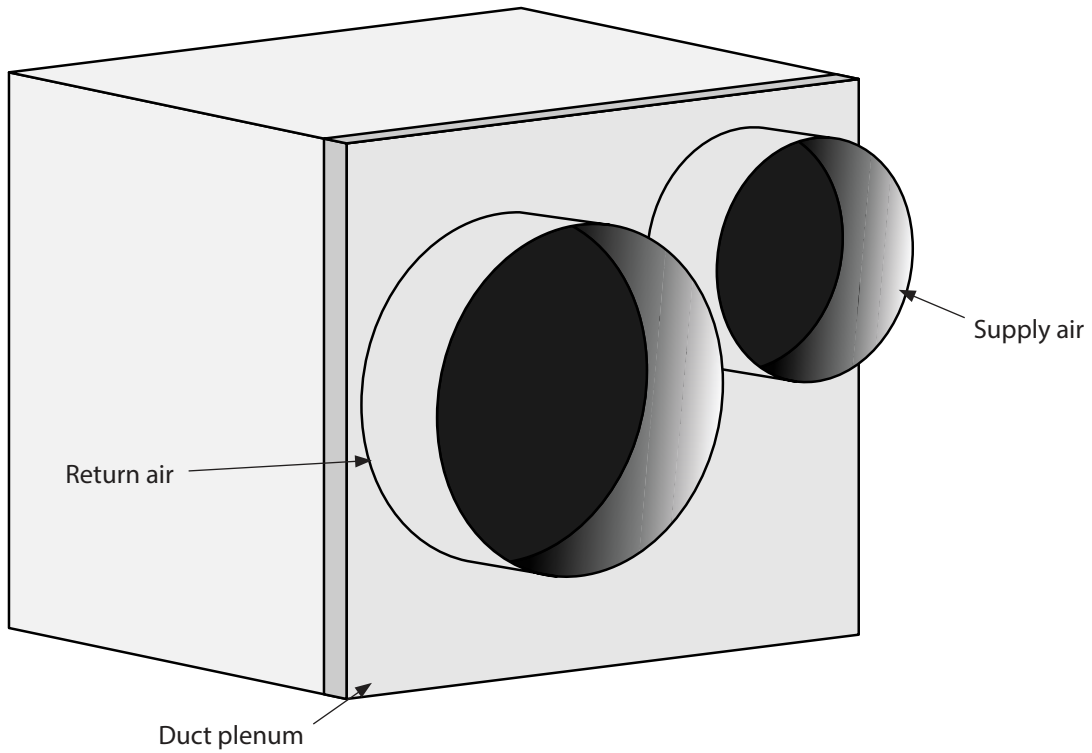

Fully Ducted — Rear / Side View

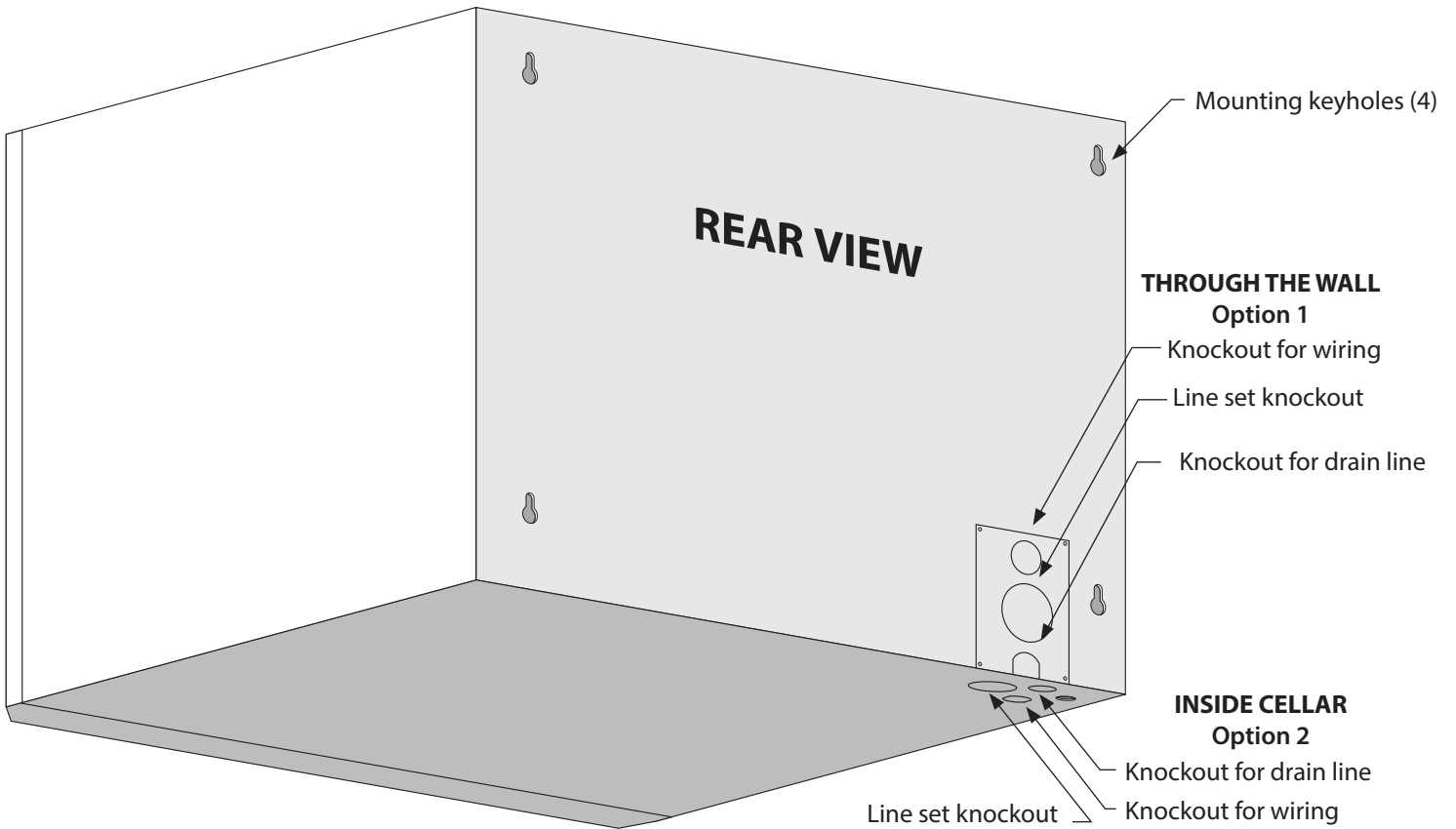

# WALL-MOUNTED TWIN SPECIFICATIONS

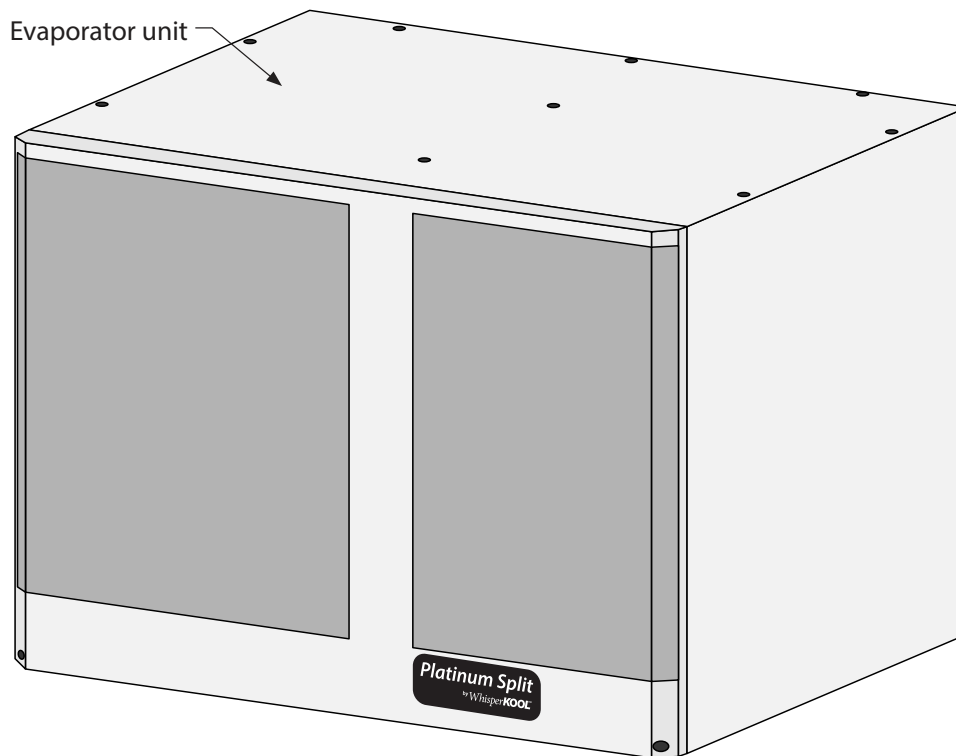

Model	9000 Master Evaporator (Fan Coil Unit)	9000 Slave Evaporator (Fan Coil Unit)
Cellar Size	Approx. 3000 cu. ft., provided cellar is fully insulated and sealed with proper vapor barrier*	
BTU/h w/85°F air entering condenser coil	Low: 6843/7845 • Medium: 7368/7959 • High: 7779/8054	
Dimensions	16.1"L x 20.5"W x 15.5"H	16.1"L x 20.5"W x 15.5"H
Refrigerant	R-134a	R-134a
Voltage Rating	115V (15-amp dedicated circuit required)	115V (15-amp dedicated circuit required)
Weight (lbs)	57	57
Amps	Evaporator: 1 running amp (per unit) Compressor: LRA 50, RLA 9.3	Evaporator: 1 running amp (per unit) Compressor: LRA 50, RLA 9.3
Line Set	Liquid line 3/8"; suction line 3/4" (less than 50 ft.), 7/8" (greater than 50 ft.)	
Drain Line	1/2" ID clear plastic tubing (not provided)	
Installation	Evaporator units are installed in the cellar.	
Thermostat	Advanced digital display (50-ft. cable), liquid-temperature-measuring bottle probe (50-ft. cable)	
Temp. Delta	Can maintain a 55°F temperature differential with up to 110°F condenser air intake temperature	
Warranty	Two-year limited warranty (parts and labor)	

\*Each cellar is unique and has specific cooling requirements. Heat load calculations should always be performed prior to selecting a cooling unit.

# FULLY DUCTED TWIN SPECIFICATIONS

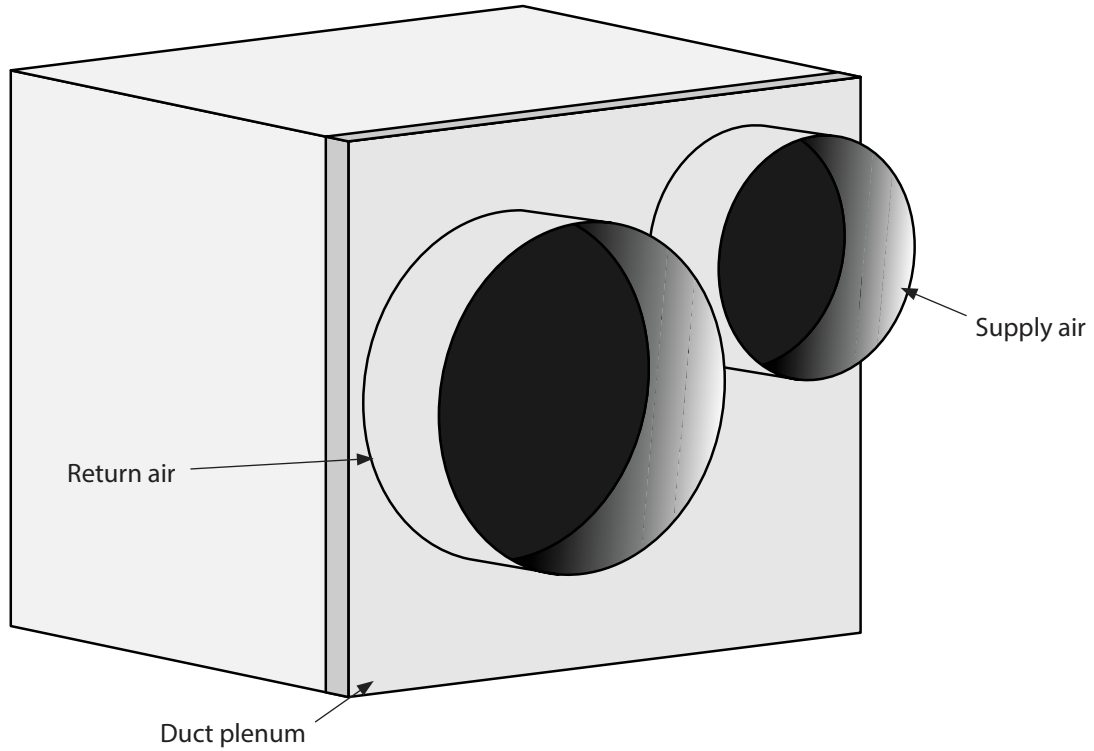

Model	9000 Master Evaporator (Fan Coil Unit)	9000 Slave Evaporator (Fan Coil Unit)
Cellar Size (cu. ft.)	Approx. 3000 cu. ft., provided cellar is fully insulated and sealed with proper vapor barrier*	
BTU/h w/85°F air entering condenser coil	Low: 6450/7366 • Medium: 7083/7657 • High: 7281/7879	
Dimensions	22.1"L x 22.5"W x 15.5"H	22.1"L x 22.5"W x 15.5"H
Refrigerant	R-134a	R-134a
Voltage Rating	115V (15-amp dedicated circuit required)	115V (15-amp dedicated circuit required)
Weight (lbs)	57	57
Amps	Evaporator: 1 running amp (per unit) Compressor: LRA 50, RLA 9.3	Evaporator: 1 running amp (per unit) Compressor: LRA 50, RLA 9.3
Line Set	Liquid line 3/8"; suction line 3/4" (less than 50 ft.), 7/8" (greater than 50 ft.)	
Duct Size	8" supply, 10" return (x2)	
Drain Line	1/2" ID clear plastic tubing (not included)	
Installation	Evaporator units can be installed up to 25 ducted feet away.	
Thermostat	Advanced digital display (connected to master unit) with 50-ft. cable; liquid-temperature-measuring bottle probe (also with 50-ft. cable)	
Temp. Delta	Can maintain a 55°F cellar temperature with up to 110°F condenser air intake temperature	
Warranty	Two-year limited warranty (parts and labor)	

\*Each cellar is unique and has specific cooling requirements. Heat load calculations should always be performed prior to selecting a cooling unit.



## CONDENSING UNIT SPECIFICATIONS

Model	9000 Condenser (Air-Cooled Condensing Unit)
Dimensions	24"L x 18.98"W x 16.16"H
Refrigerant	R-134a
HP	Ducted system: 3.1, non-ducted system: 3.34
Voltage Rating	230V (15-amp dedicated circuit required)
Weight (lbs)	75
Installation	Condensing unit can be installed up to 100 line feet from master evaporator unit.
Warranty	Two-year limited warranty (parts and labor)

## SPLIT SYSTEM CHECKLIST

In order to activate the warranty for this product, the information here must be complete and accurate. Any incorrect or omitted information will result in a return trip by the installing technician at their cost.

### DATA RECORDINGS

**NOTE: All readings need to be taken while the compressor is running.**

#### Line Set Information

- A. Line set length:
- B. Suction line OD:
- C. Liquid Line OD:

#### Bottle Probe

- A. Install probe in bottle of warm water to keep system operating.

#### Charging the System

- A. Fill system until bubbles dissipate from sight glass.  
**NOTE: Be careful not to overcharge the system.**

#### Temperature Differential at the Evaporator

- A. Measure return air and supply air temperatures at each evaporator to ensure adequate cooling of air in cellar.

#### Sub Cooling

- A. Measure head pressure at liquid line king valve. Convert pressure to temp using conversion chart.
- B. Temp of liquid line at king valve:
- C. Complete sub cooling calculation:  $A - B =$

#### Superheat Master

- A. Measure suction pressure at the suction line service valve, convert to temp.
- B. Measure the temperature of the suction line at the outlet of the evaporator.
- C. Complete superheat calculation:  $B - A =$   
**NOTE: There may be a need to adjust the TXV to get the correct superheat levels.**

#### Superheat Slave

- A. Measure suction pressure at the suction line service valve, convert to temp.
- B. Measure the temperature of the suction line at the outlet of the evaporator.
- C. Complete superheat calculation:  $B - A =$   
**NOTE: There may be a need to adjust the TXV to get the correct superheat levels.**

#### Compressor Temperature

- A. Measure temperature at bottom of compressor.  
**NOTE: Cool temp may indicate liquid in the compressor.**

#### Voltage and Amp Draw

- A. Measure voltage to compressor and amp draw.

#### Condensation Drain Test

- A. Pour water into each evaporator unit's drain pans to ensure they drain properly.

## ITEMS TO ROUTE BEFORE INSTALLING THE EVAPORATOR UNITS

1. Route the refrigerant lines from each evaporator unit toward each other using  $\frac{3}{8}$ " OD copper tubing for the suction line and  $\frac{1}{4}$ " OD tubing for the liquid lines.
2. Join both suction lines together using a  $\frac{3}{8}$ " T-fitting. Install a  $\frac{3}{4}$ " to  $\frac{3}{8}$ " reducer at the outlet of the T-fitting. The remainder of the suction line from the T-fitting to the condensing unit will need to be  $\frac{3}{4}$ " OD copper tubing. (See page 34 for detailed piping diagram.)
3. Join both liquid lines together using a  $\frac{1}{4}$ " T-fitting. Install a  $\frac{3}{8}$ " to  $\frac{1}{4}$ " reducer at the inlet of the T-fitting. The remainder of the liquid line from the T-fitting to the condensing unit will need to be  $\frac{3}{8}$ " OD copper tubing. (See page 34 for detailed piping diagram.)
4. Route the display cable from the desired location to the desired master evaporator unit installation location (see page 22 for more display information).
5. Route the bottle probe cable from the desired thermostat bottle location to desired master evaporator unit installation location (see page 21 for more bottle probe information).
6. Route the drain lines from a proper discharge location to the desired evaporator unit installation locations (see page 20 for more drain line information).
7. Route the power cable wiring to the desired evaporator unit installation locations.
8. Route an 18-5 thermostat wire between the desired evaporator unit installation locations.

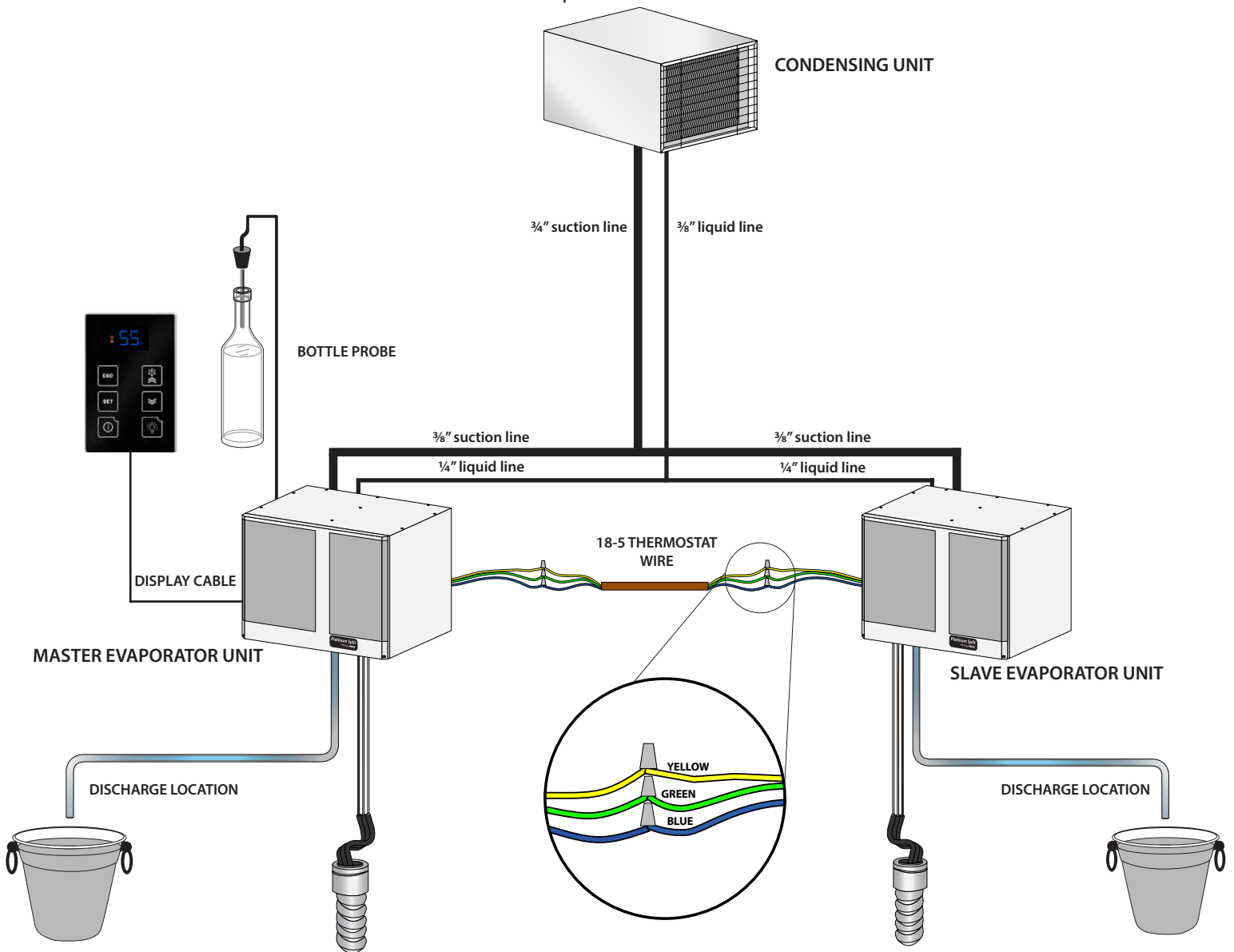

# PREPARING THE WALL-MOUNTED EVAPORATOR UNITS

## Required Tools:

- Drill
- 5/32" drill bit
- 1/4" socket drill bit
- 1/4" wrench
- Phillips-head screwdriver
- Tape measure
- Brazing torch
- Drywall saw
- Ladder
- Level
- Pliers
- Pencil

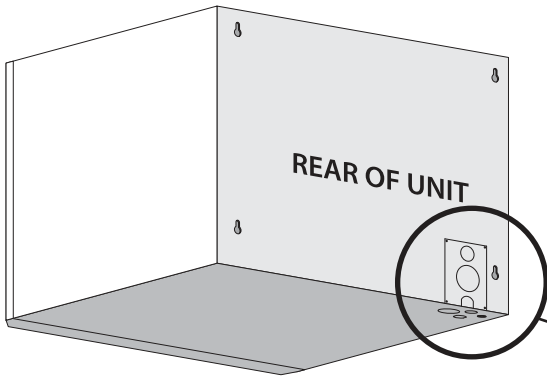
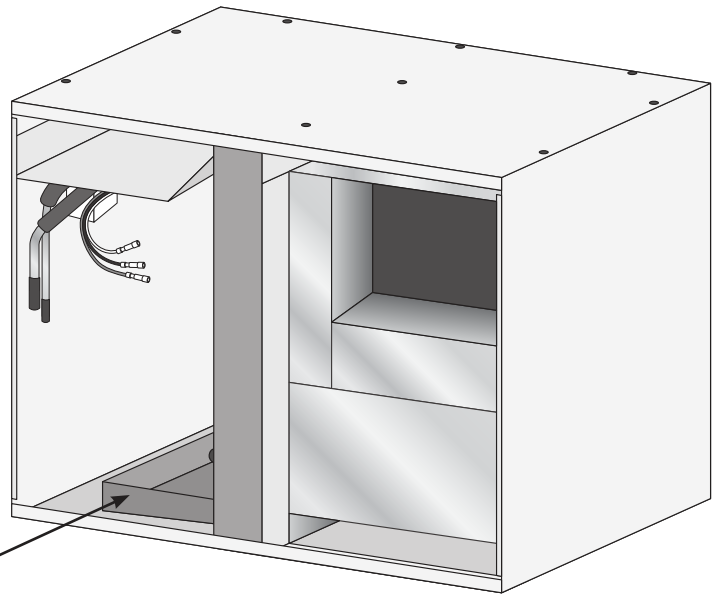

Drain pan

Rear panel

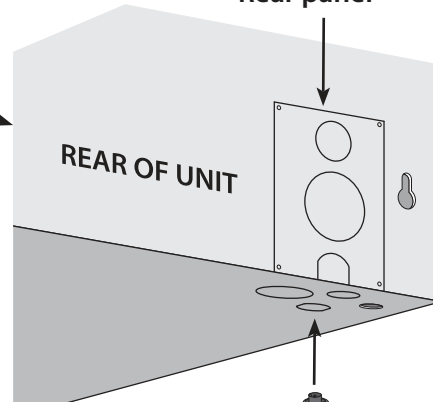

Power

Line set

Drain line

Bottle probe connector routing location

1. Remove the rear panel and set aside.
2. For ease of installation, remove the nine (9) screws securing the top and remove the top.

## INSTALLING THE WALL-MOUNTED EVAPORATOR UNITS

Refer to the Wall-Mounted Evaporator Unit Installation Template for more information about mounting the wall-mounted evaporator units.

1. Locate two (2) wall studs in the desired mounting location spaced 16" on center.
2. Mark vertical lines on each stud 16" apart.
3. Mark an intersecting horizontal line at the desired height of the unit.
4. Make a mark on each stud 13½" down from the intersection of the horizontal and vertical lines.

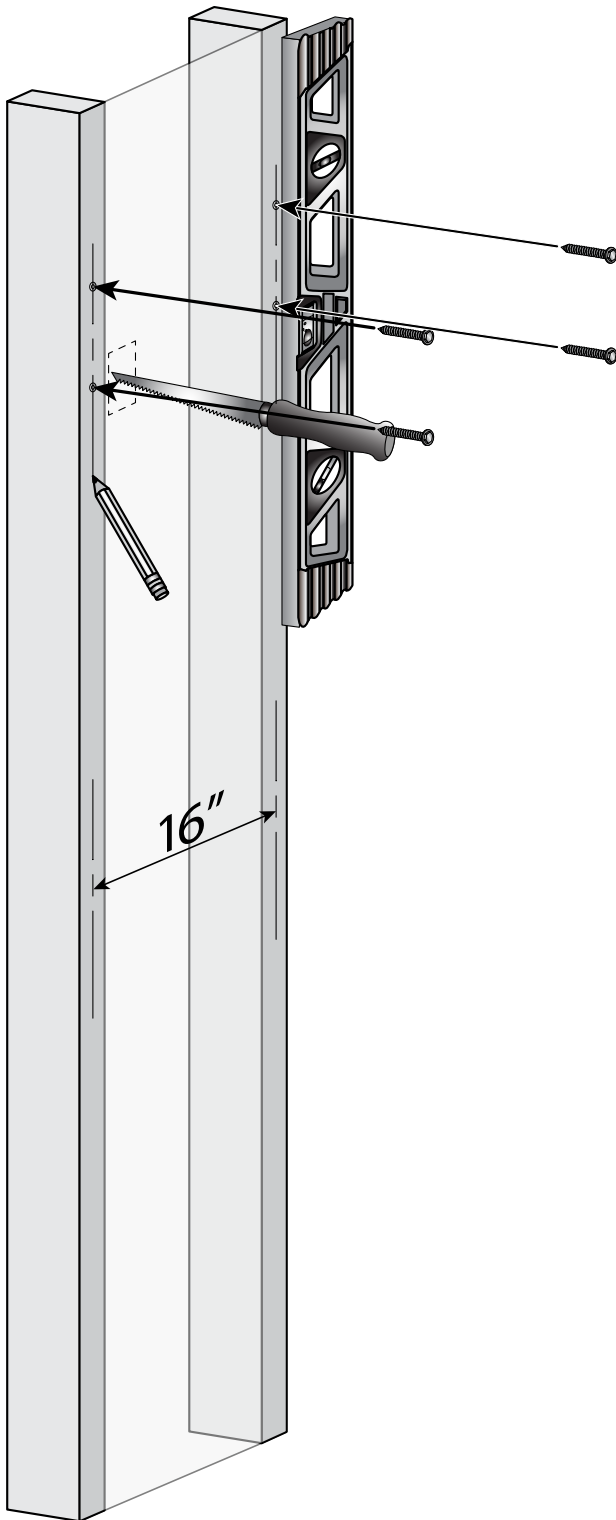

**NOTE:** The top of the unit must be installed a minimum of 6" and a maximum of 18" from the ceiling.

5. Install the four (4) supplied 1¾" hex-head screws into the studs at the locations marked leaving ⅛" between the wall surface and screw head.
6. If routing through a wall, cut out an access hole for the line set, drain line, display cable, and power wires.
7. Raise the evaporator to the installation location. Align the rear keyholes with the mounting screws and mount the unit.
8. Using a ¼" wrench or socket, tighten the top mounting screws.
9. Using ¼" and ⅜" copper tubing, route the liquid and suction lines through the knockouts in the housing. Be sure to extend the tubing far enough outside of the housing to extend through the wall if necessary.
10. Wrap both sides of the copper tubing with a wet rag to prevent overheating.
11. To prevent oxidation, purge the system with nitrogen.
12. Braze the copper tubing to the connections on the evaporator unit.

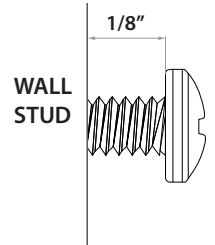

WRAP WITH WET RAGS

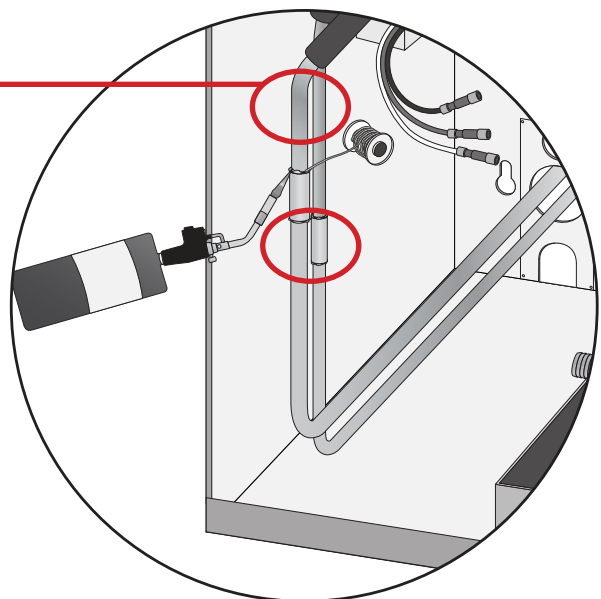

13. Insulate the suction line using Armaflex or similar insulation.
14. Using the cable ties and cable tie mounts provided, secure the drain line to the bottom of the housing to ensure a downward slope.
15. Route the power wire, bottle probe connector, and display cable into the unit through the knockouts.
16. Connect the power wires according to color: connect the ground wire to the green wire, the hot wire to the black wire, and the neutral wire to the white wire.
17. Locate the thermostat wire connections inside of the master unit.
18. Connect the 18-5 wire that was routed between the evaporators according to color (yellow to yellow, red to red, and green to green).
19. Install the supplied black strain relief to secure the power supply wires in the housing.

20. Connect the display cable labeled "UNIT" to the wire labeled "UNIT" located in the bottom of the evaporator compartment.

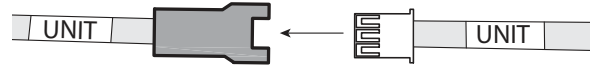

21. Attach the supplied bottle probe to the circular connector on the bottom of the unit (see Figure 1). Follow the directions on page 21 for correct installation and placement of the bottle probe.
22. Secure all wiring neatly and as close to the left wall as possible in order to minimize airflow obstruction.
23. Seal the gaps around the display cable, bottle probe connector, and power wire knockouts using the supplied three-inch pieces of cork tape. (For best results, install the cork tape inside of the unit.)
24. Repeat steps 1-23 with the second evaporator unit. (Steps 20 and 21 do not apply to the slave unit.)
25. Follow the directions on page 37 for correct installation of the wall mount grille.

**Figure 1**

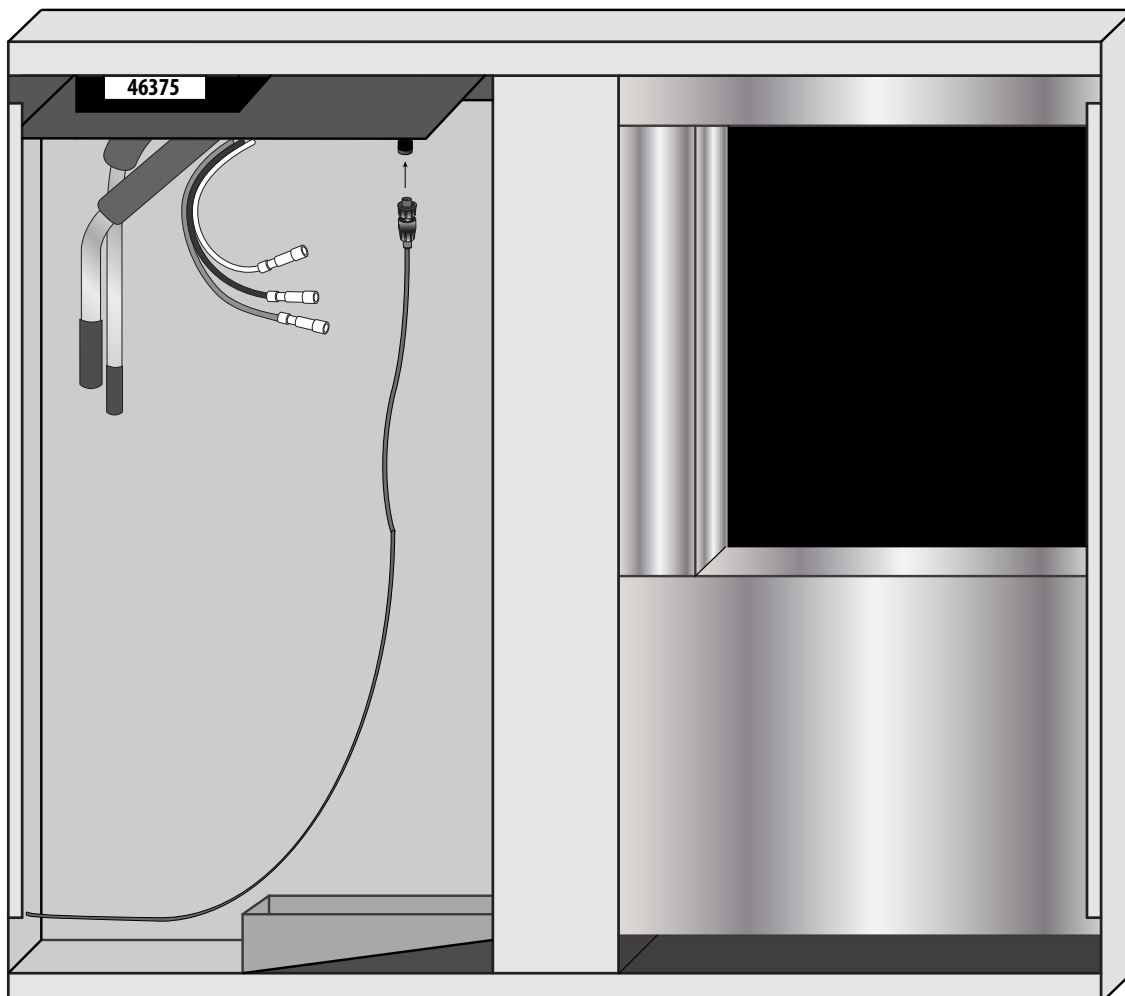

## PREPARING THE FULLY DUCTED EVAPORATOR UNITS

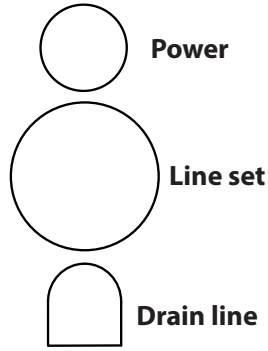
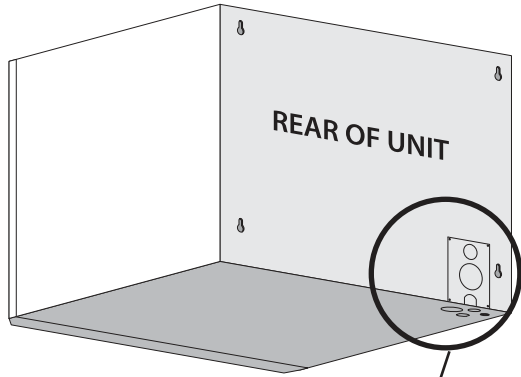

1. Remove the knockouts that you will be using to route the line set, power wires, and drain line.
2. Remove the insulation from the knockout holes.
3. For ease of installation, remove the nine (9) screws securing the top and remove the top.
4. Follow the directions on page 22 to mount the remote display and run the display cable to the evaporator unit.

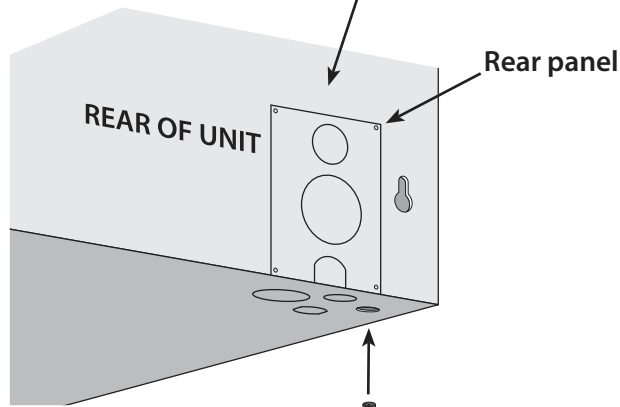

Bottle probe connector routing location

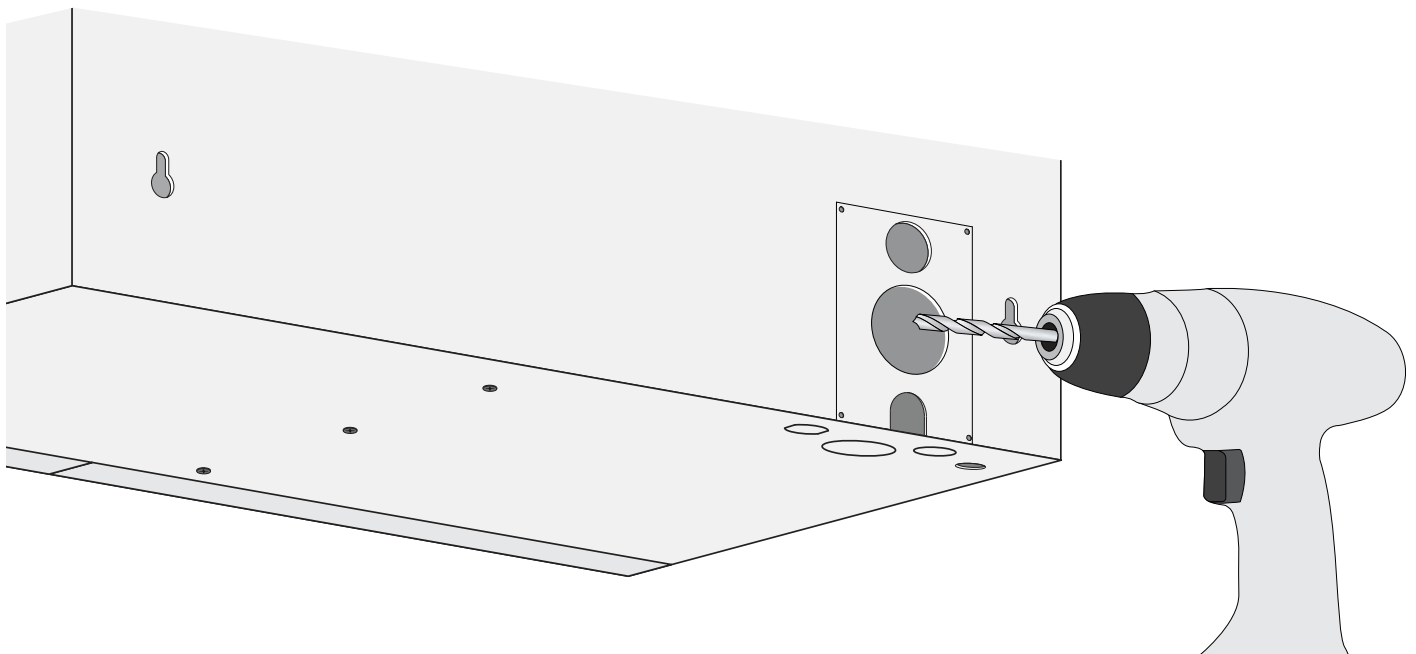

## INSTALLING THE FULLY DUCTED EVAPORATOR UNITS

1. Using ¼" and ⅜" copper tubing, route the liquid and suction lines through the knockouts in the housing. Be sure to extend the tubing far enough outside of the housing to extend through the wall if necessary.
2. Wrap both sides of the copper tubing to prevent overheating.
3. To prevent oxidation, purge the system with nitrogen.
4. Braze the copper tubing to the connections on the evaporator unit.
5. Insulate the suction line using Armaflex or similar insulation.
6. Using the cable ties and cable tie mounts provided, secure the drain line to the bottom of the housing to ensure a downward slope.
7. Route the power wire, display cable, and the bottle connector through the knockouts.
8. Connect the power wires according to color: connect the ground wire to the green wire, the hot wire to the black wire, and the neutral wire to the white wire.
9. Locate the thermostat wire connections inside of the master unit.
10. Connect the 18-5 wire that was routed between the

evaporators according to color (yellow to yellow, red to red, and green to green.)

11. Install the supplied black strain relief to secure the power supply wires and bottle probe wire in the housing.
12. Connect the display cable labeled "UNIT" to the wire labeled "UNIT" located in the bottom of the evaporator compartment.
13. Attach the supplied bottle probe to the circular

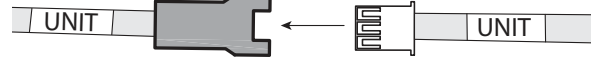

connector on the bottom of the electrical panel. (See Figure 1.) Follow the directions on page 21 for correct installation and placement of the bottle probe.

14. Secure all wiring neatly and as close to the left wall as possible in order to minimize airflow obstruction.
15. Seal the air gaps around the display cable, bottle probe cable, and power wire knockouts by installing the supplied three-inch pieces of cork tape. (For best results, install the cork tape inside of the unit.)
16. Repeat steps 1-15 with the second evaporator unit. (Steps 12 and 13 do not apply to the slave unit.)
17. Follow the directions on page 37 for correct installation of the ducted plenum.

Figure 1

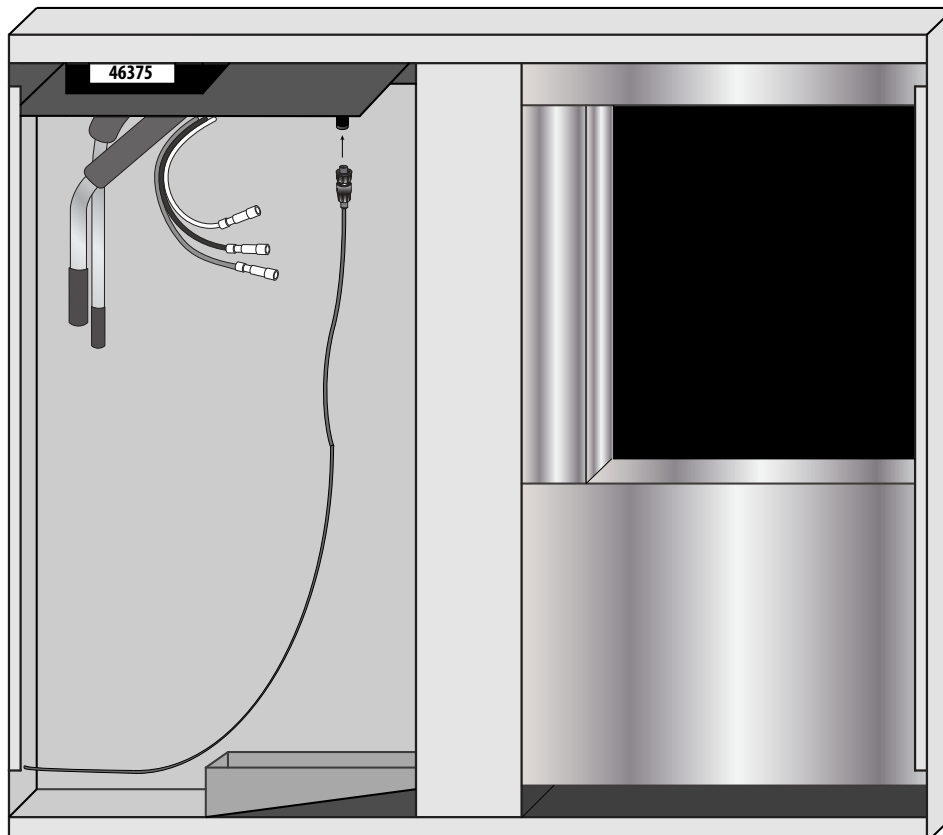



## DUCTING OVERVIEW

Use ductwork to connect the unit to the supply and return outlets in the wine cellar. Use only insulated ductwork to minimize cooling losses, prevent sweating, and reduce noise. Use ductwork on the condenser section to redirect or absorb sound, bring in outside air to the unit inlet, and/or exhaust the hot air.

**NOTE:** Do not exceed a total of 25 feet for each length of ductwork run and a combined total of 50 feet for both the supply and return lengths.

Avoid crimping the flexible ducts. This reduces airflow, causing the unit to operate improperly. Be sure all ductwork and outer surfaces in contact with the airflow are insulated and have a vapor barrier on the outside. Uninsulated supply and return ducts may cause bare, exposed metal surfaces to sweat, further degrading the insulation and equipment cooling capacity.



**Do not allow sharp turns to squeeze or decrease the inside diameter of the flexible ducting.**



### General duct recommendations:

- Provide support for the flexible duct to prevent sags and bends.
- Platinum Split Twin duct size: 8" supply and 10" return
- Stretch out the duct to make a smoother interior which reduces air resistance.
- Maximum duct length is 25 feet per evaporator unit.
- For 90° bends, use a 90° adjustable elbow.
- No more than two 90° bends on each duct. Sweep 90° bends are recommended rather than sharp 90° bends.

**NOTE:** For every 90° bend, the system loses 13 CFM of airflow.

**NOTE:** A 12" x 12" return air filter grille must be installed to prevent contaminants from entering the cooling system. Supply duct must be insulated so it does not sweat or pick up heat.

- Generously apply duct sealant to all metal seams to fill in gaps that can leak air. Allow sealant to dry until firm to the touch before applying fiberglass insulation.
- Do not squeeze or reduce the inside diameter of the ducts, as this will reduce airflow.
- Use short and straight ductwork where possible.
- Check that all fan blades move freely.
- Keep air paths free of loose foreign objects and debris.
- To provide adequate airflow the fan speed must be set to high when the unit is ducted.
- Locate the supply and return grilles inside the cellar to create an airflow pattern that maximizes air circulation in the room. Avoid short circulation of the air.
- If the unit is installed through the wall, it must be mounted no more than 18 inches from the wine cellar ceiling. If the unit is ducted, the cold air supply duct must be installed no more than 18 inches from the wine cellar ceiling.

### DO NOT:

- Install through-the-wall return air grilles at floor level where they will collect dust from the floor.
- Locate the supply or return air grille where it is blocked by bottles, boxes, or cases.

## DUCTING CONFIGURATIONS

There are several ways to duct this unit. Please review the different configurations to determine a basis for your particular installation. Remember to contact a wine cellar professional if you have any questions.

### Indoor Installation

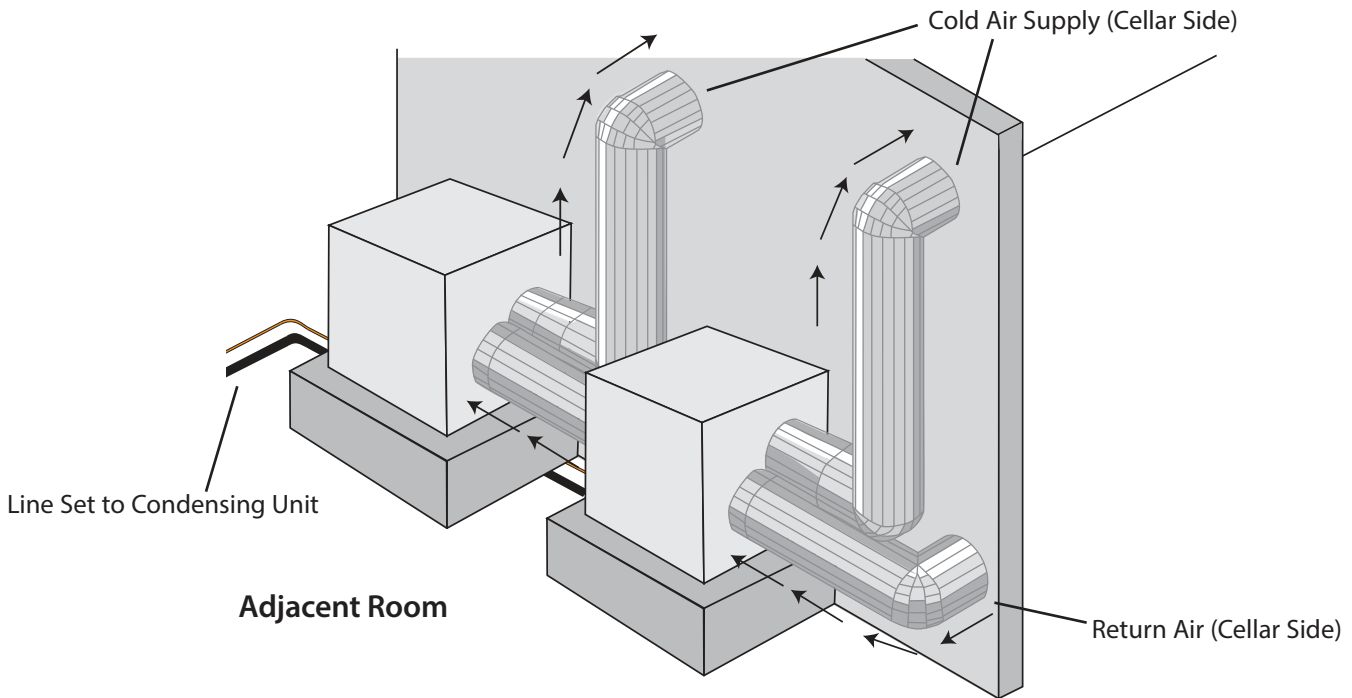

### Attic Installation

It is recommended that you use a condensate pan for this application.

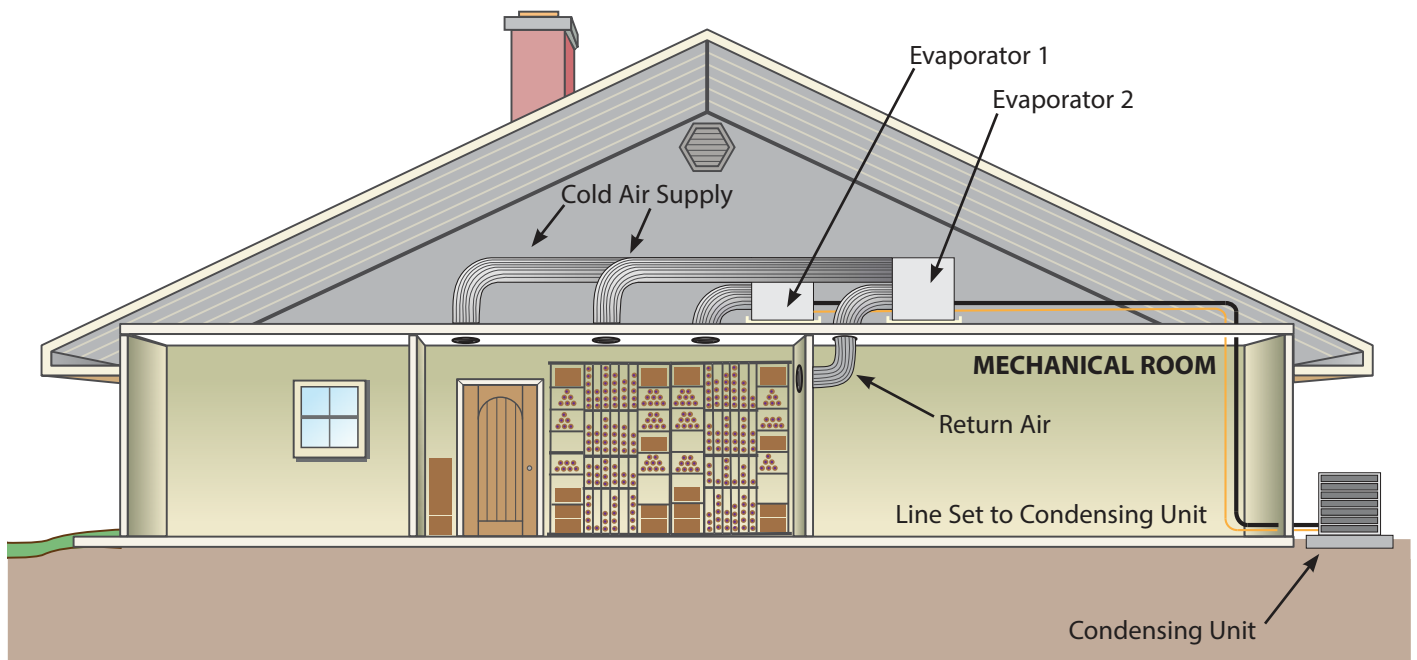

## DRAIN LINE

### Condensation Drain Line (not provided, but required)

The condensation drain line tube moves excess condensation from the evaporator unit to a proper discharge location. It is important for the drain line tube to be properly connected in order to prevent leakage and other problems associated with excess condensation. (Each evaporator requires its own dedicated drain line.)

**Failure to use the condensation drain line tube will void the warranty on the unit.**

### Drain Line

Each evaporator comes with a drain line connection tee and two 90° fittings. Each unit is equipped with a 1/2" OD barbed fitting coming from the drip tray. (**NOTE:** 1/2" ID clear PVC tubing will need to be purchased and installed by the installing technician.) Installation of the drain line is mandatory, whether it leads through the wall and out of the cellar or remains inside the cellar. During operation, the cooling system will strip excess water from the air in order to maintain the proper level of humidity within the cellar. However, in extreme humidity, additional condensate will be removed; thus the drain line will prevent overflow and leakage by discharging the excess condensate.

### Routing the tubing out of the unit:

Cut a small piece of 1/2" tubing and connect one end to the drip tray port and the other to a 90° fitting. (This will direct the tubing toward the back of the unit where the tube will exit the unit.) Be sure to extend the tubing far enough outside the housing to extend through the wall if necessary.

**If routing out of the rear:** Cut a piece of tubing long enough to protrude out of the knockout on the back side of the unit.

**If routing out of the bottom:** Cut a piece of tubing long enough to reach the knockout in the bottom of the unit and install the supplied 90° fitting. (This will direct the tubing out of the bottom of the unit without the risk of kinking the tubing.) **DO NOT USE TEE WHEN ROUTING OUT OF THE BOTTOM.**

### Routing to discharge location if routed out of the bottom:

Connect the drain line directly to the second 90° barb fitting previously installed. Route the drain line to an appropriate drain location. No tee is required if draining through the bottom of the unit.



**WRONG:** Drain line is under water.

### Routing to discharge location if routed out of the rear:

Insert the middle barb of the barbed tee fitting into the end of the drain line coming from the evaporator. Rotate fitting so tee is in the orientation shown in the diagram below. Connect a 3-inch piece of 1/2" drain line to the barb on top. Connect the remaining "long" piece of drain tubing to the bottom barb of the tee. Route the drain line to an appropriate drain location.

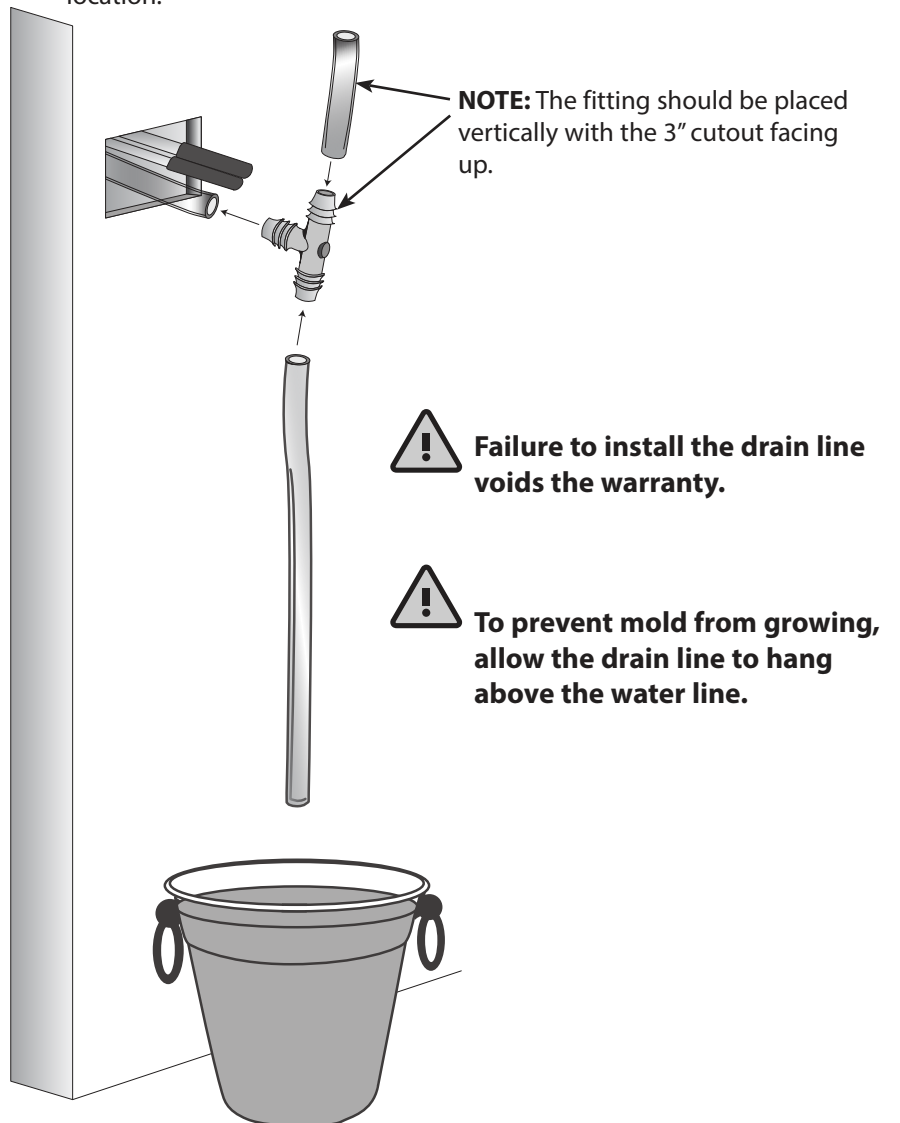

## LIQUID-MEASURING THERMOSTAT SYSTEM (BOTTLE PROBE)

WhisperKOOL cooling units come with a liquid-temperature-measuring thermostat. The self-calibrating probe contains a sensor chip, which communicates back and forth with the thermostat. This results in a consistent temperature setting and accuracy. Wine should be kept at a very precise, controlled temperature and humidity. By measuring the liquid temperature rather than air, the unit will operate 75–80% of the time. (Both units will run according to the master unit's bottle probe.)

### Setting up the Bottle Probe:

1. Locate an empty wine bottle.
2. Fill it 75% full with room-temperature tap water.
3. Place bottle probe securely into bottle as seen in Figure 1.
4. Place bottle off to the side of the unit in your wine cellar, with the probe level.
5. To ensure a consistent temperature, place bottle probe approximately three (3) feet away from the air output and not in the flow of the air.

**It is recommended that the bottle be placed in a central location of your wine cellar.** Avoid pulling too much on the probe cord. It may become disconnected resulting in limited functionality of the unit.

**NOTE:** The thermostat can be set between 50–70°F.

**Remember:** The unit operates based on the temperature of the water. Do not be misled by thermostats reading air temperature. The air temperature in the cellar will be cooler than the liquid temperature of the wine while it is reaching the optimum balanced temperature.

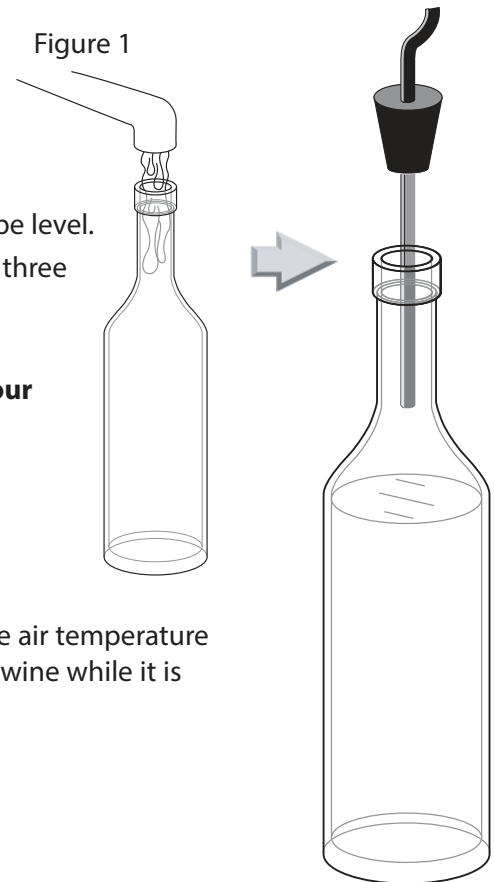

## REMOTE DISPLAY: INSTALLATION AND CONFIGURATION

**Tools needed:** 5/16" drill bit, 3/16" drill bit, drywall saw, level, pencil

**What's included:** Display panel, wall mount bracket, flush mount bracket, flush mount template



Display panel

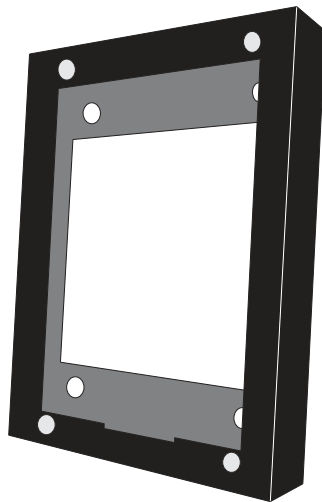

Wall mount bracket

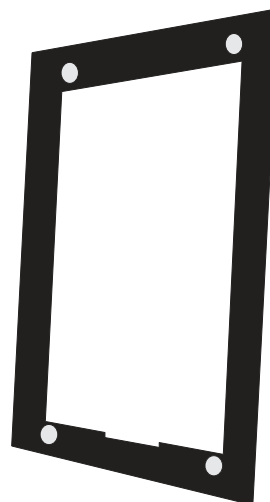

Flush mount bracket

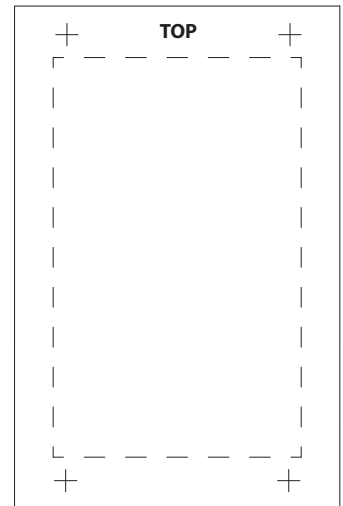

Flush mount template

### WALL MOUNT BRACKET INSTALLATION

1. Place the bracket on the wall. Use a level to ensure that the bracket is level. Using a pencil, mark the four screw holes in the rear of the bracket.

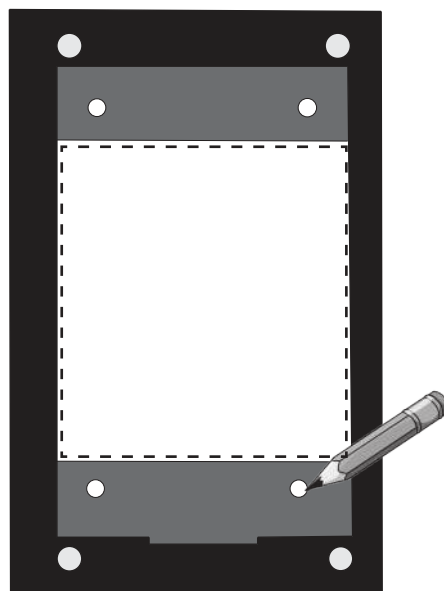

**NOTE:** Cut hole in the location shown for routing the display cable.

## WALL MOUNT BRACKET INSTALLATION, CONTINUED

2. Using a drill with a  $\frac{3}{16}$ " bit, drill four holes in the drywall for the screws. Insert the four (4) provided drywall anchors into the drywall, then tap them in with a hammer until they are flush with the wall.

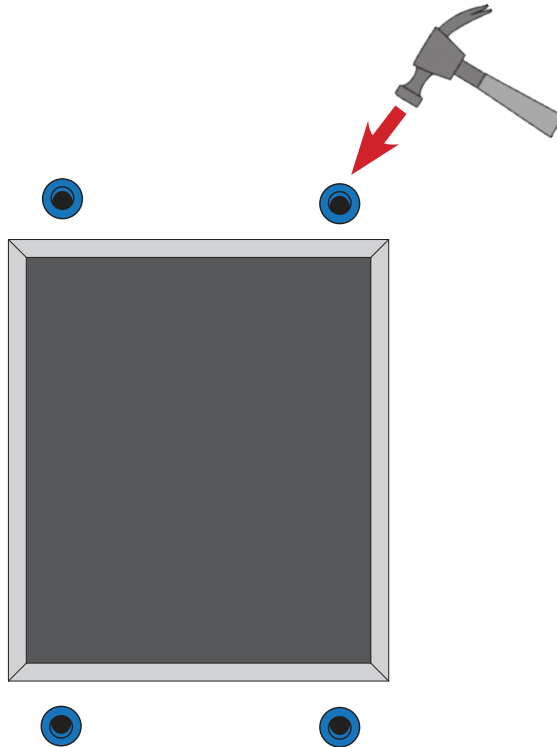

3. Place bracket against wall, aligning screw holes with drywall anchors. Insert the four supplied Phillips-head screws into the drywall anchors. Tighten the screws to secure the bracket to the wall.

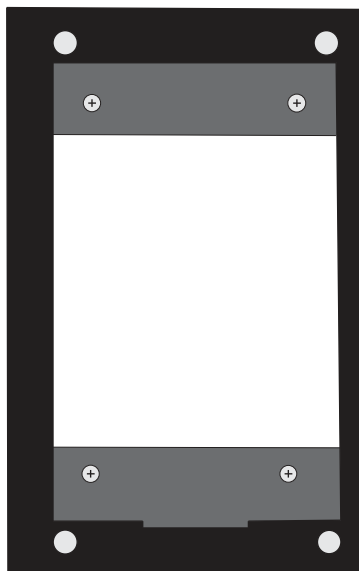

## WALL MOUNT BRACKET INSTALLATION, CONTINUED

**NOTE:** Before you continue to Step 4, locate the area where the display will be mounted. You may route the display wire into the housing one of three ways: either through the wall or through one of the holes on the top or bottom edges of the wall mount bracket. If you'd like to route the display cable through one of these holes, place a rubber grommet into the hole and then route the display cable through the grommet and into the wall mount bracket.

4. Connect the end of the display cable labeled **"DISPLAY"** to the JST connector on the back of the display.

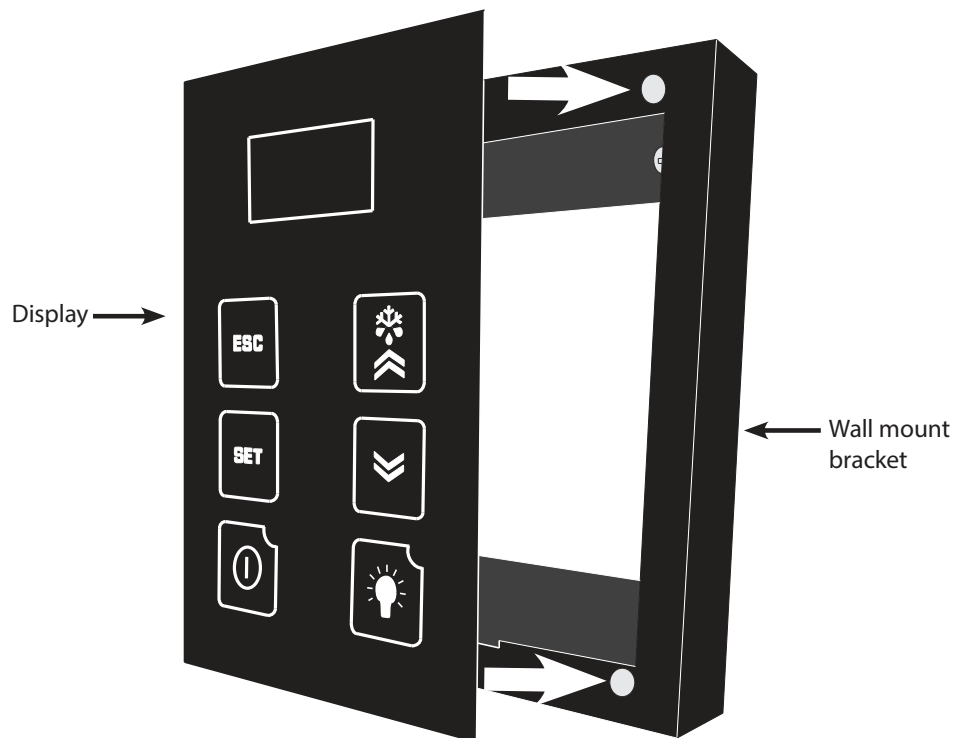
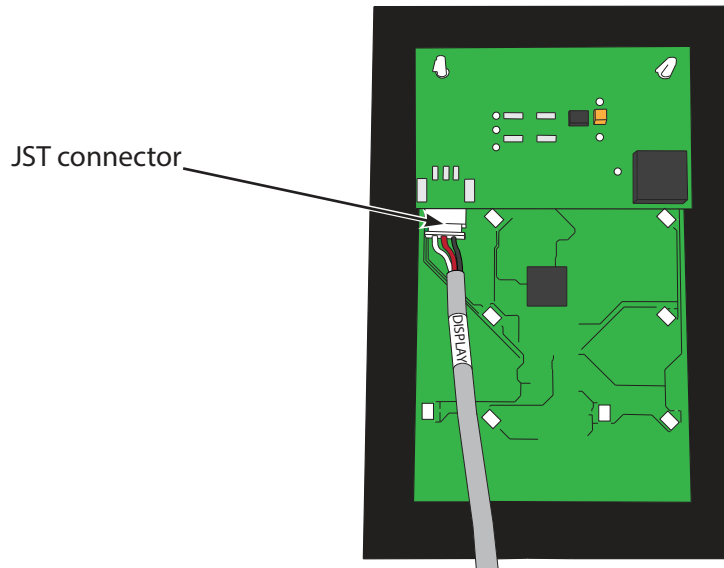

5. Place the display on the wall mount bracket as shown, attaching the back of the display panel to the magnets on the mounting bracket. Make sure that the alignment tab on the back of the display panel sits in the notch on the bottom of the bracket.

## FLUSH MOUNT BRACKET INSTALLATION

1. Square the flush mount template on the wall using a level. Then draw a 3" line along the bottom edge of the template.

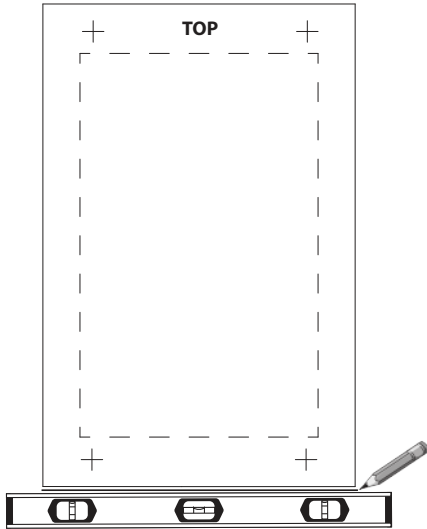

2. Peel the backing off the template and stick it to the wall, aligning the bottom edge with the line drawn in Step 1.

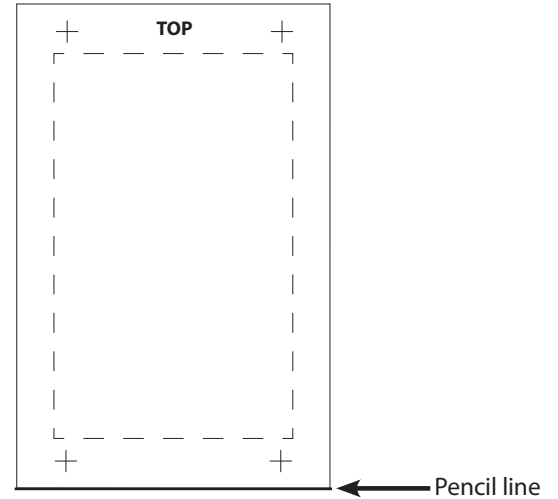

3. Use a  $\frac{5}{16}$ " drill bit to drill a hole in the center of each cross (+).

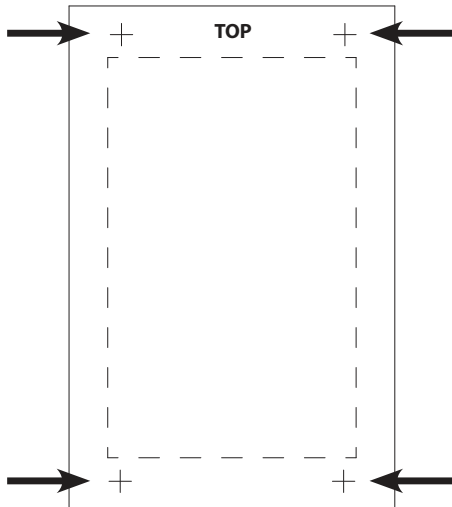

4. Cut along the perforated lines. When finished, remove template from wall.

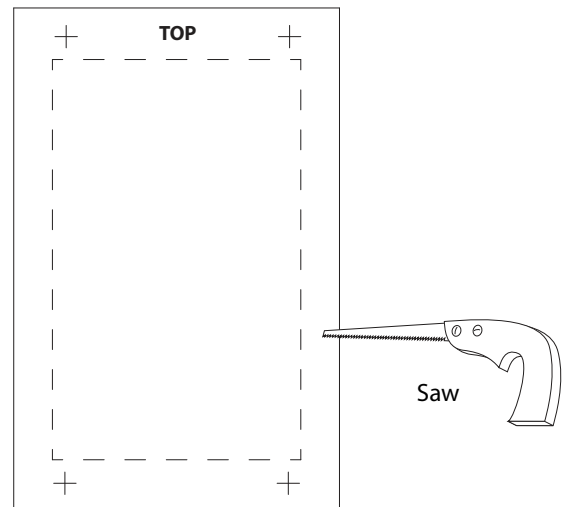



## FLUSH MOUNT BRACKET INSTALLATION, CONTINUED

5. Remove the backing from the double-sided tape on the flush mount bracket.



6. Align magnets with previously drilled holes. Make sure the cut-out portion of the bracket (circled below) is on the bottom. Press the bracket firmly against the wall.

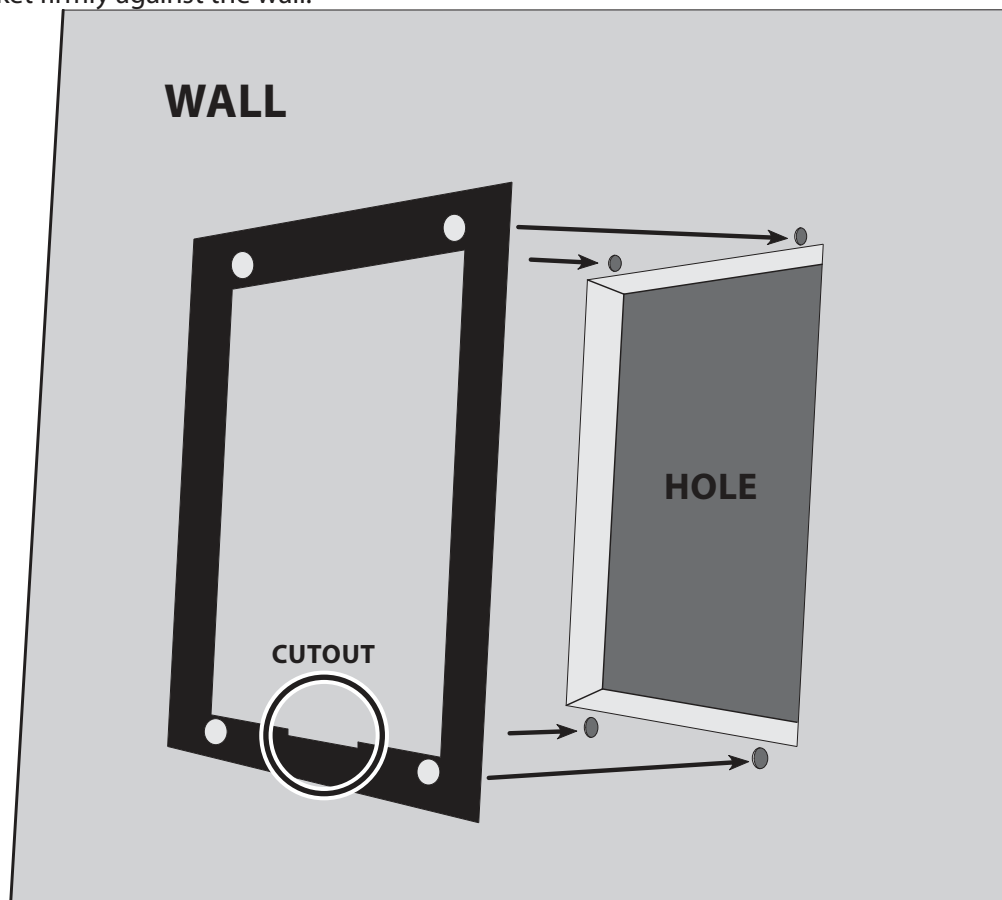

## FLUSH MOUNT BRACKET INSTALLATION, CONTINUED

7. Connect the end of the display cable to the JST connector on the display panel.

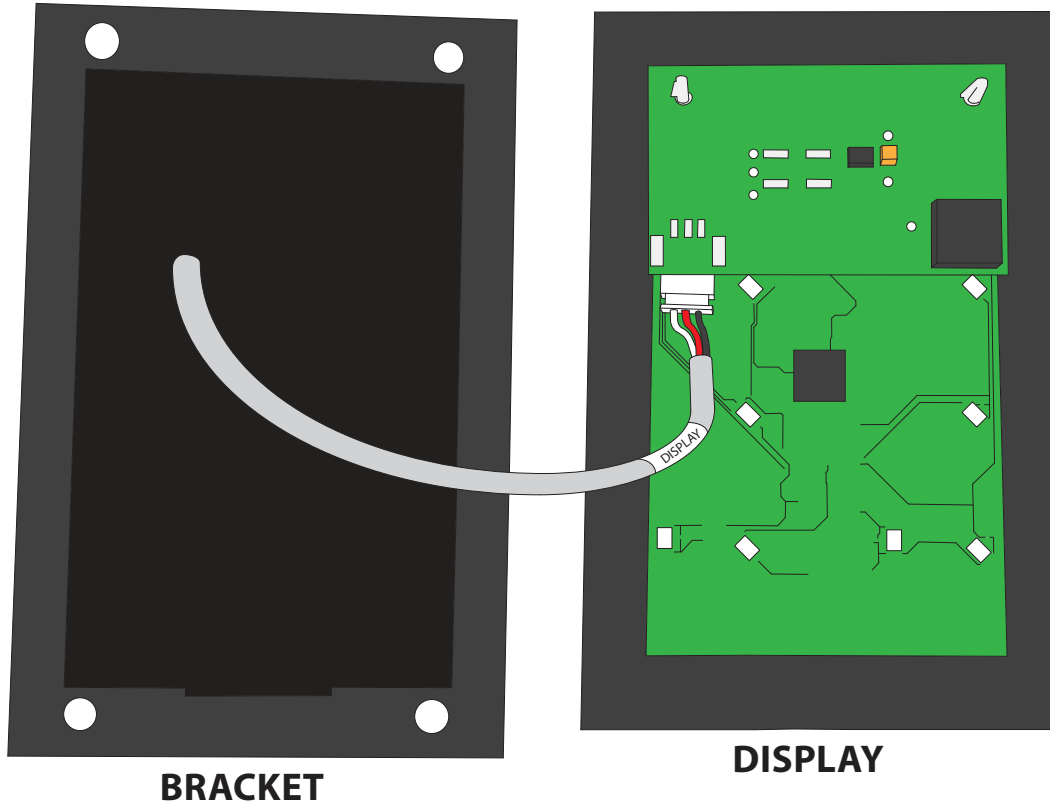

8. Place the display on the flush mount bracket as shown, attaching the back of the display panel to the magnets on the mounting bracket. Make sure that the alignment tab on the back of the display panel sits in the notch on the bottom of the bracket.

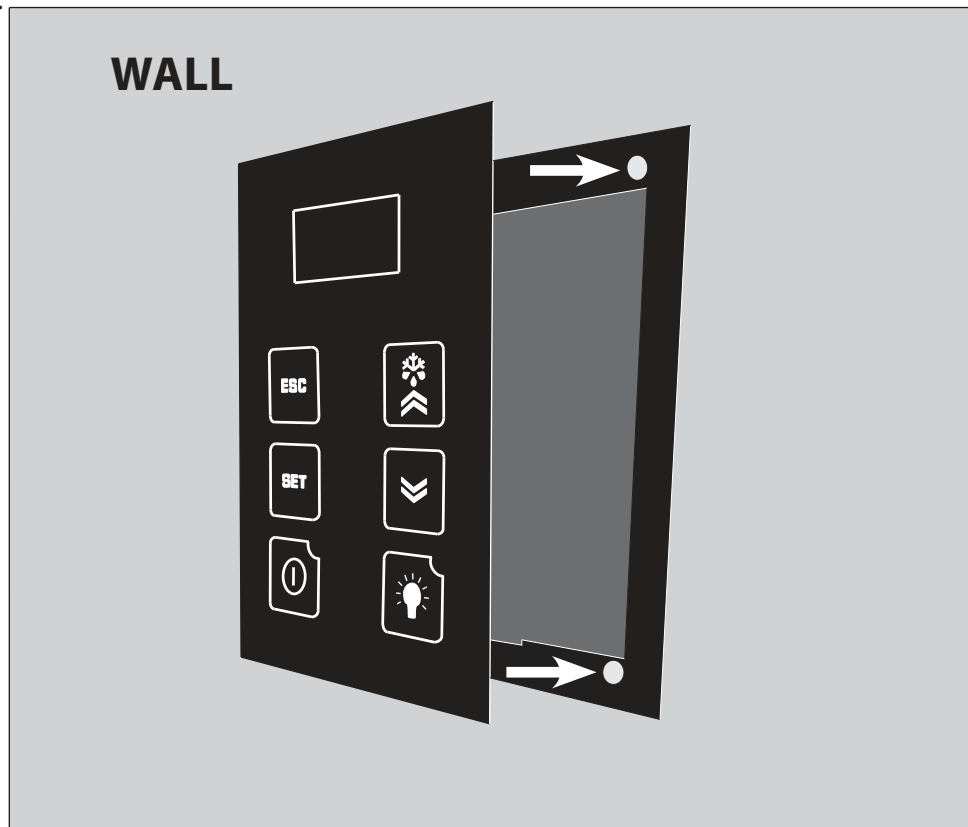

# PLATINUM SPLIT TWIN WIRING DIAGRAM

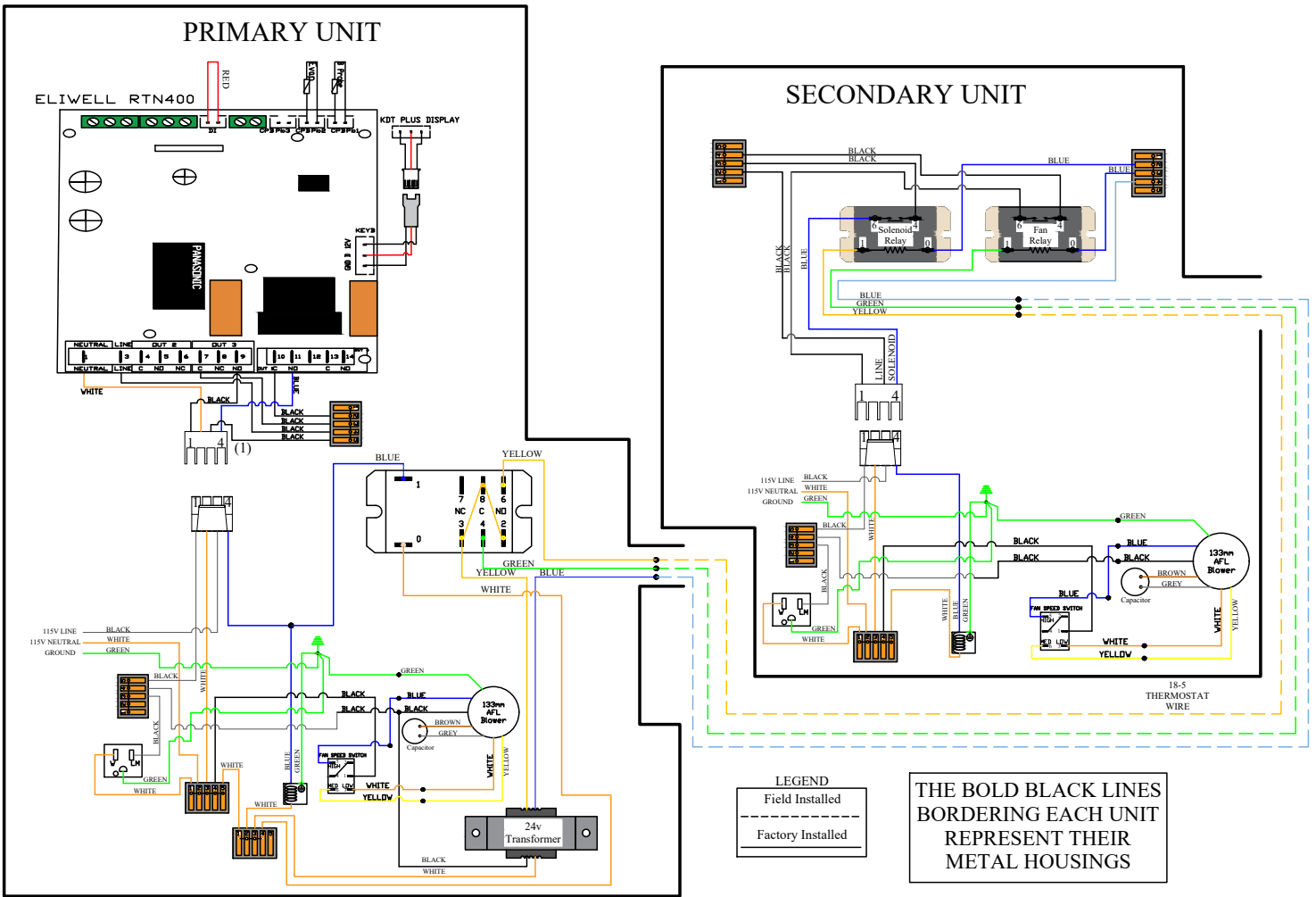

# PLATINUM SPLIT TWIN MASTER EVAPORATOR WIRING DIAGRAM

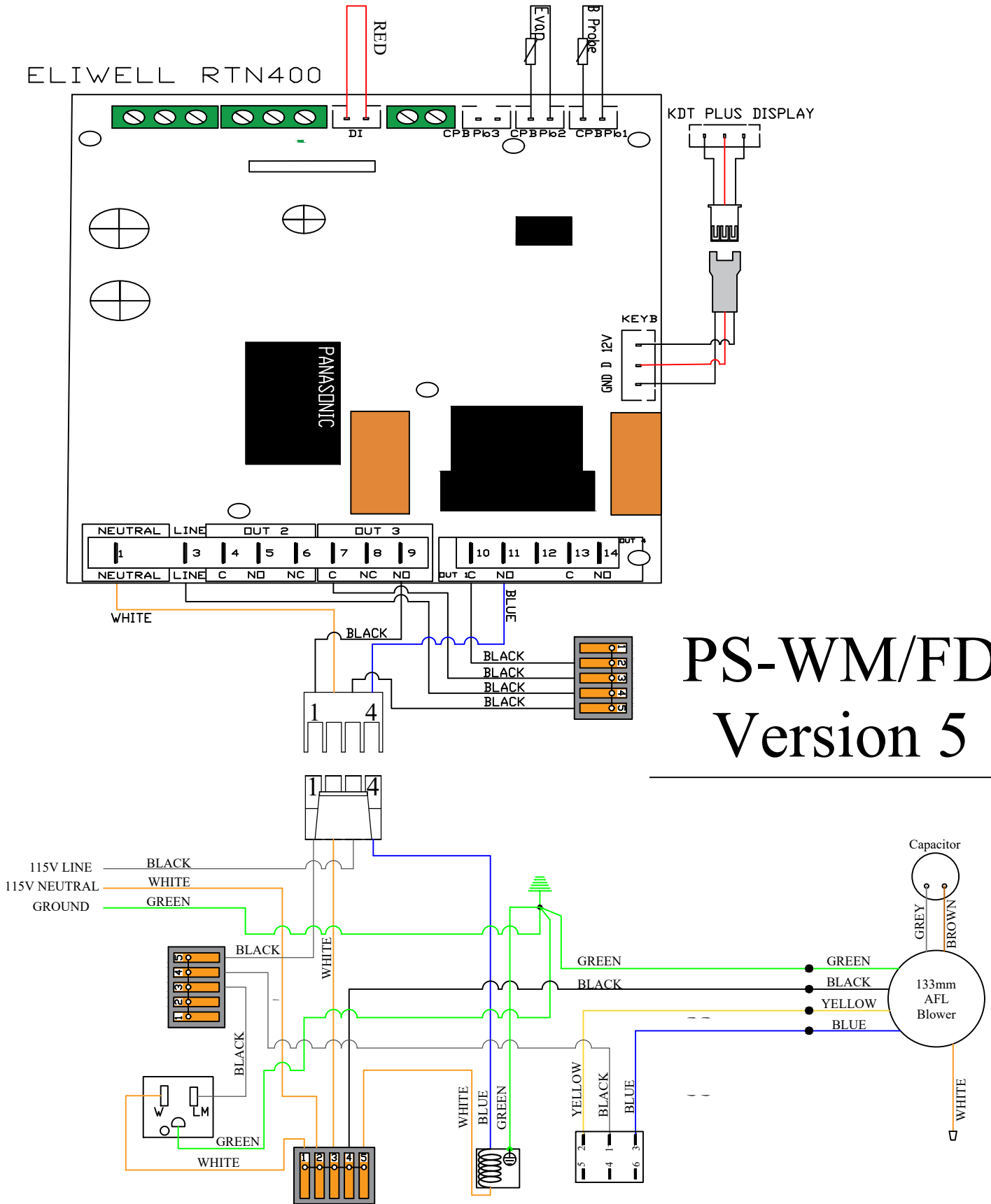

## PS-WM/FD Version 5

# PLATINUM SPLIT TWIN SLAVE EVAPORATOR WIRING DIAGRAM

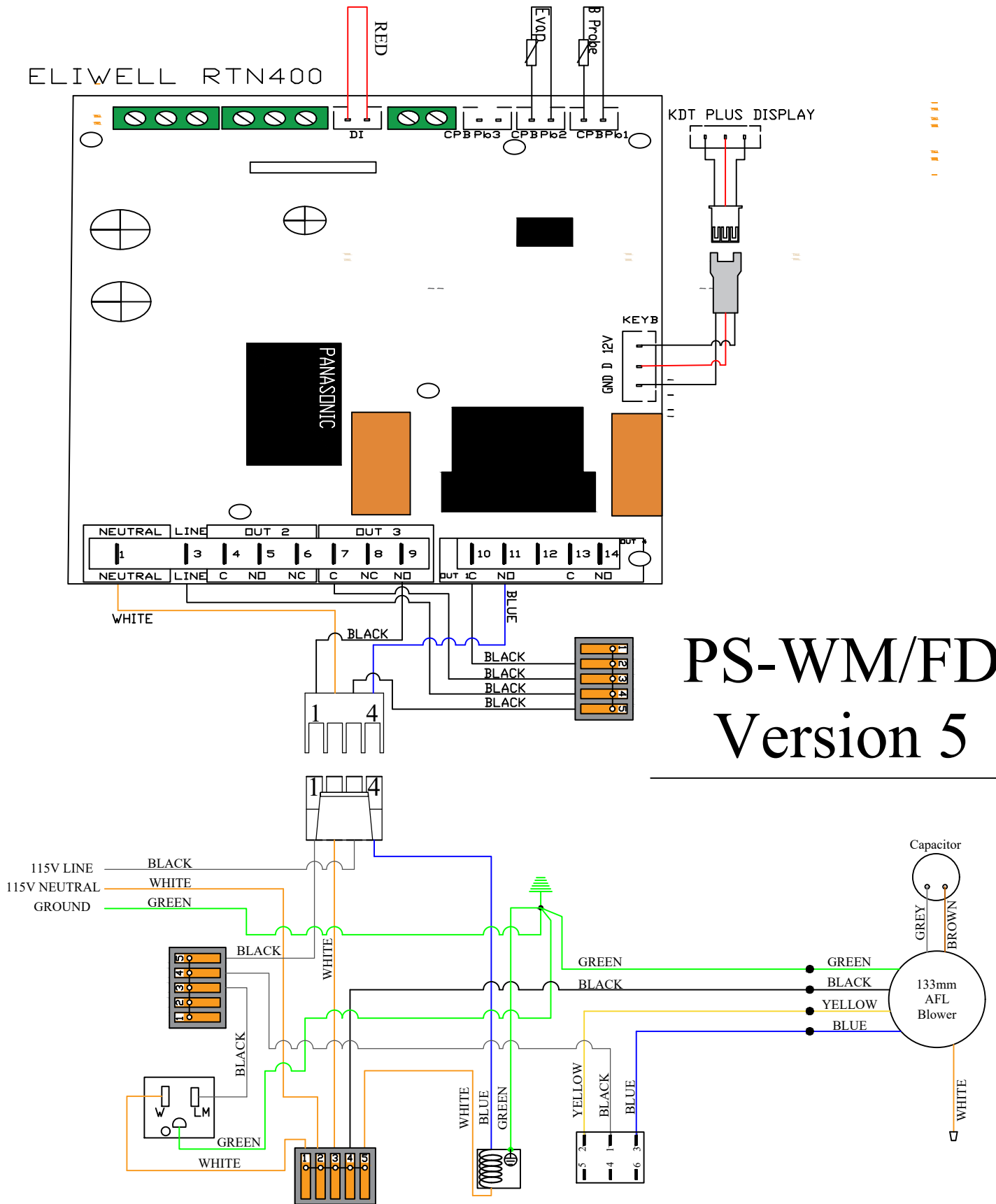

**PS-WM/FD**  
**Version 5**

# PLATINUM SPLIT TWIN 9000 CONDENSING UNIT WIRING DIAGRAM

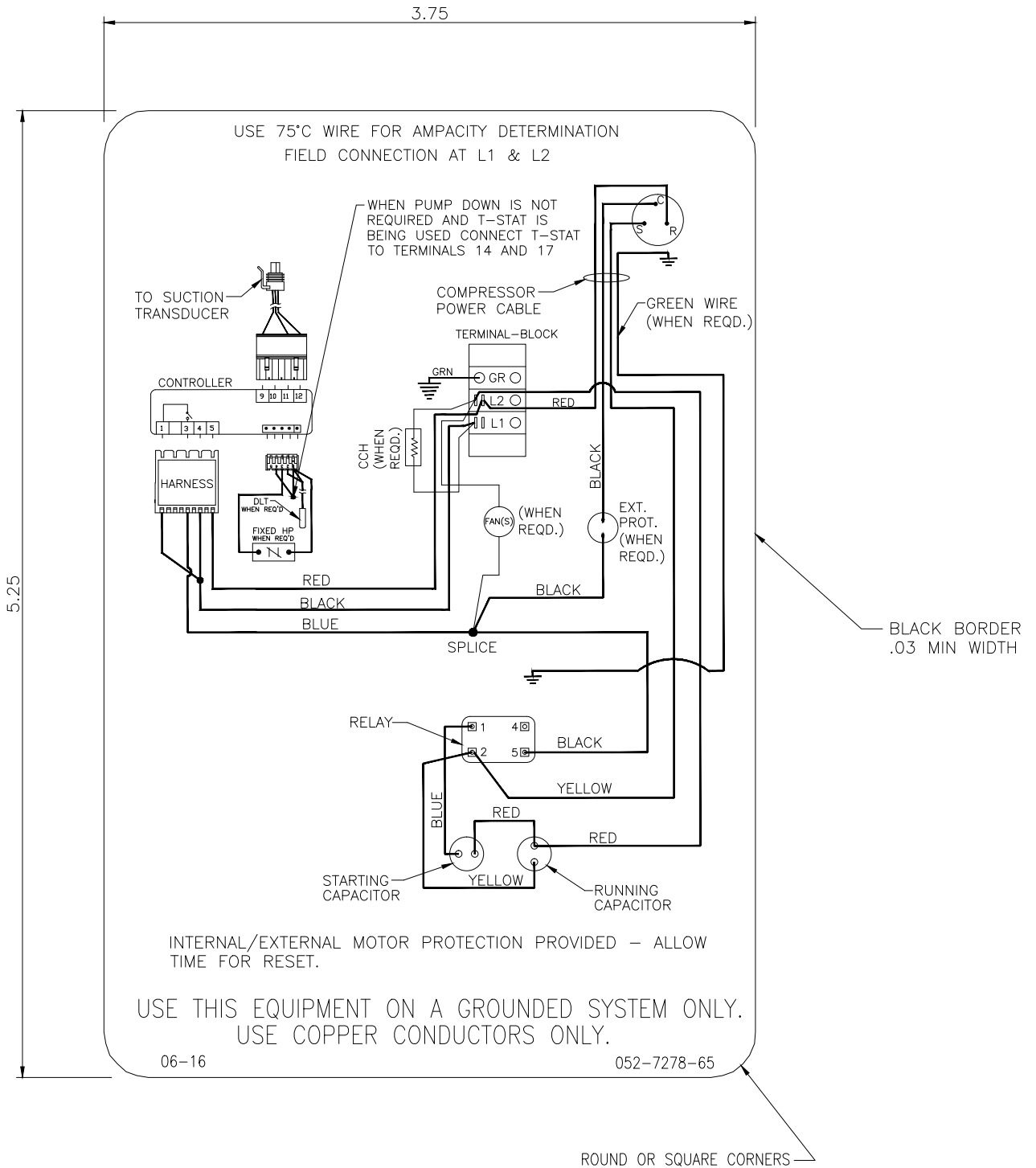

## COPELAND COLD WEATHER START KIT WIRING DIAGRAM

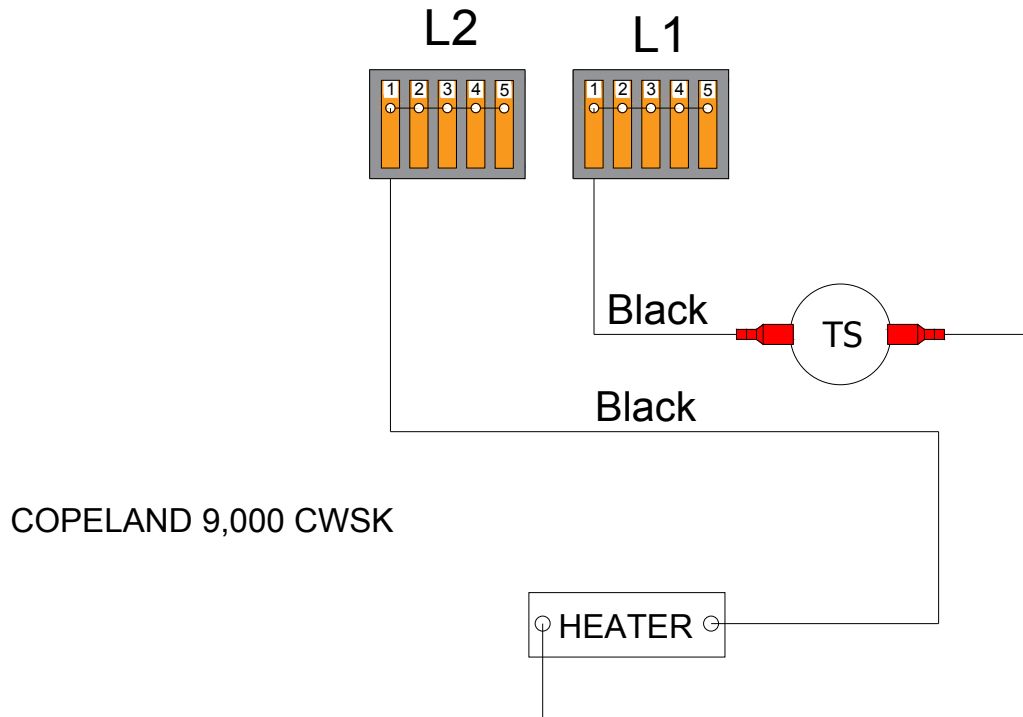

## PREPARING THE CONDENSING UNIT

### Electrical Needs

**The condensing unit requires a dedicated 230V single-phase 15-amp circuit.** The unit draws a large inrush current for about 1 second the instant the compressor starts. With a dedicated circuit and circuit breaker, the condensing unit will have sufficient power for effective operation. (The compressor is controlled by a low-pressure switch mounted on the condensing unit. This feature eliminates the need for wiring between the evaporator unit/fan coil unit and the condensing unit.)

- Ensure the voltage supplied matches the rating specified on the unit spec label.
- Provide a dedicated circuit and circuit breaker for the condensing unit.
- Provide a weatherproof disconnect for the condensing unit if it is located outside.

Power surges and spikes can damage sensitive electrical equipment. WhisperKOOL recommends plugging the unit into a surge protector or power conditioner in order to protect your system. As outlined in our terms and conditions, power surges and spikes are not covered under warranty.

**DO NOT USE A GROUND FAULT INTERRUPTER (GFI) WITH THIS PRODUCT.**

In case the system should lose power, check the home/main circuit breaker. If the system does not respond properly, refer to the Troubleshooting Guide on page 50.

## INSTALLING THE CONDENSING UNIT

The condensing unit can be installed inside a well-ventilated area of the home, but is typically installed outside. Exterior applications will require the use of a protective housing. The amount of sun exposure should be considered when selecting the placement of the condensing unit. The condensing unit requires a dedicated 15-amp circuit (non-GFI). **Make sure there is a minimum of three (3) feet of horizontal clearance in every direction around the unit (five feet is ideal).** The unit may either be hard-wired or plug-in, depending on local electrical codes.

**Indoor condensing unit installations:** Inside installations require special consideration, as there must be adequate ventilation to remove the heat created during normal operations. An exhaust port with fan may need to be installed to ensure that heat is effectively removed from the utility room. There must be a return grille or provision for 500 - 600 CFM of cool air to enter the room to replace the exhausted air. Unobstructed airflow to and from the unit is a critical factor in the unit's overall performance. **Make sure there is a minimum of three (3) feet of horizontal clearance in every direction around the unit (five feet is ideal).** This will assure that the unit can move the air around the room in an efficient manner.

**Outdoor condensing unit installations:** You must utilize the exterior condensing unit housing for outdoor installations. Place the condensing unit on a solid foundation in a location with adequate ventilation. **Make sure there is a minimum of three (3) feet of horizontal clearance in every direction around the unit (five feet is ideal).** The unit should be elevated 18 inches in order to avoid any possible flooding or damage by animals, and should be clear of leaves, dirt, and other debris.



# LINE SET PIPING DIAGRAMS

It is required to size the suction line tubing according to this chart.

Platinum Split Twin	Line Set Length	<25ft	26-50ft			50-100ft			
	Vertical Rise	15ft	<3ft	3-10ft	>10ft	<3ft	3-10ft	>10ft	
	Suction Line Sizing	3/4"					7/8"		
	Liquid Line Sizing	3/8"			3/8"				

## Condensing Unit Installed Below Fan Coil

### Option 1

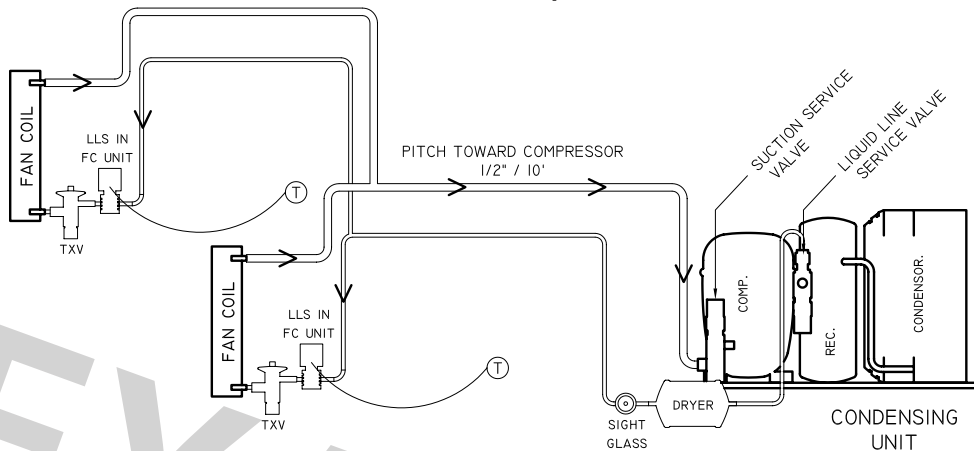

#### SINGLE FAN COIL PIPING SYSTEM

RECOMMENDED REFRIGERANT PIPING DESIGN FOR CONVENTIONAL FACTORY SUPPLIED FAN COIL AND AIR COOLED CONDENSING UNIT COMPONENTS. REFRIGERANT LINE LENGTHS IN EXCESS OF 90' NOT RECOMMENDED.

THIS DRAWING APPLIES TO CONDENSING UNIT LOCATION AT OR BELOW THE ELEVATION OF THE FAN COIL UNIT. SUCTION PIPE TO BE INSULATED WITH 1/2" WALL INSULATION (ARMAFLEX BRAND) OR EQUAL.

## Condensing Unit Installed More Than 3' Above Fan Coil

### Option 2

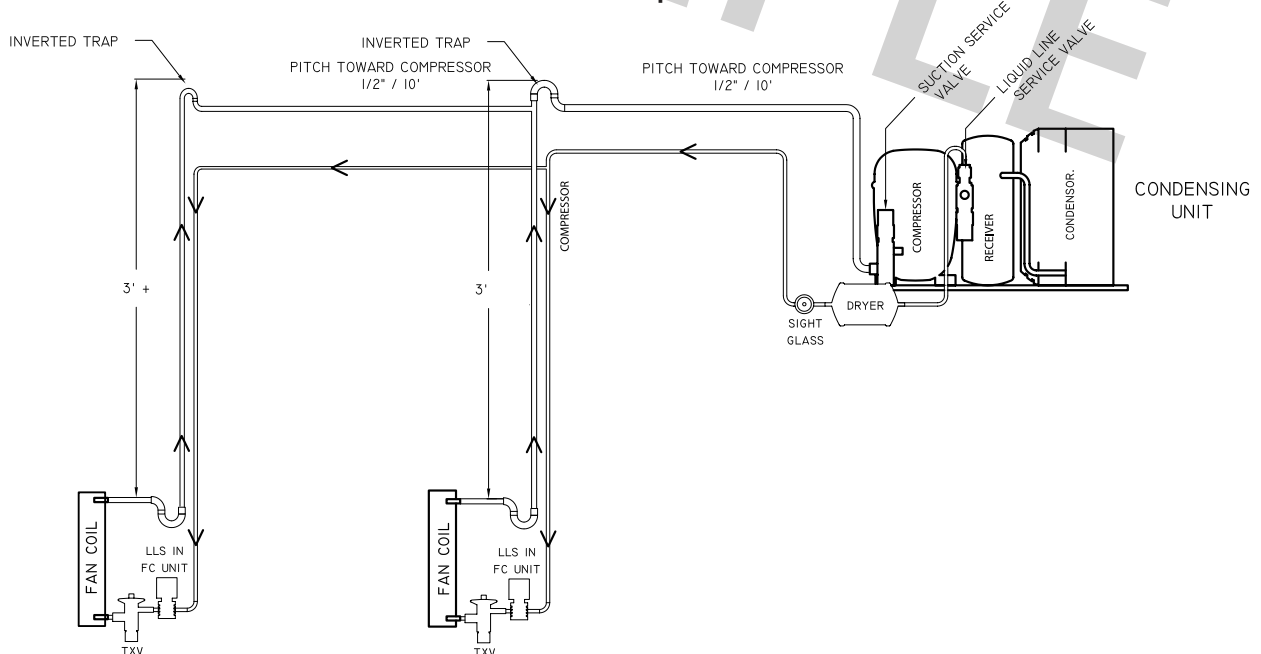

# INSTALLING THE CONDENSING UNIT

**DO NOT BLOCK** airflow through the exterior housing. This will restrict airflow and void the warranty.

## Refrigerant Piping Overview

- Using the charts and illustrations found above, route the line set between the evaporator units and the condensing unit. Be sure to reference the chart for correct line set sizing. All horizontal suction piping should be pitched toward the condensing unit half an inch for every 10 feet of pipe. When installing and routing the line set, cap both ends of each tube to prevent debris from entering the tubing.
- Prior to connecting the piping to the evaporator and condensing units, loosely connect a refrigerant manifold to the suction and liquid line service valves.
  - Purge the hoses with dry nitrogen and tighten the hose connections.
  - Remove the service valve caps and turn the valve stem clockwise half a turn to unseat the valve and open the service port. Keep the piping ports sealed until ready to braze.
- Purge the fittings with dry nitrogen at a slow rate to prevent formation of highly abrasive copper oxide.
- Perform all brazes.
- Pressure-test the system and check for leaks.
- Insulate the suction line using wall cellular insulation or equivalent. Seal all seams with Armaflex 520 foam insulation adhesive or equivalent. Wrap each seam using line set tape.

## Liquid Line Piping Procedure

- Braze a short piece of copper tubing to the liquid line service valve.
- Connect the supplied refrigerant drier to the tubing.
- Downstream from the drier, connect the moisture-indicating sight glass in an easily visible location.
- Run the tubing to the evaporator units and attach to the liquid line connection on the evaporator units.

## Suction Piping Procedure

- Install an access valve at the outlet of the evaporator units.
- Connect an appropriately sized suction line to the suction line service valve on the condensing unit.
- Run the pre-insulated suction line to the evaporator units and attach to the suction line connection on the evaporator units.

## Brazing Procedure

- Connect the bottle probe to the master evaporator unit.
- Fill a wine bottle 75% full of room-temperature water. Insert the bottle probe into the neck of the bottle as far as possible. It is important that the bottle probe stopper be compressed by the neck of the bottle to ensure water will not leak.
- Energize the master evaporator unit and set the controller to call for cooling.
- Verify that the setpoint on the control is set low enough to allow the unit to run for the entire length of the brazing, evacuation, and charging procedure.
- Remove the valve depressors from the gauge hoses on a four-valve manifold.
- Connect the manifold to the low-pressure service valve port on the condensing unit and a nitrogen tank.
- Open the suction line service valve and purge the system with nitrogen.
- Braze all connections and cool off quickly.
- Cap the access valve on the suction line.
- Connect the high-pressure hose from the manifold to the liquid line service valve port.
- Pressure test the system at 250 psig for 30 minutes.
- Check all braze joints with leak detector or soap bubbles.
- Release the nitrogen once it is confirmed that there are no leaks.

## INSTALLING THE CONDENSING UNIT (continued)

### Evacuation

- Remove the nitrogen tank from the manifold and attach the manifold to the refrigerant tank.
- Install a micron gauge on the access valve near each evaporator unit.
- Mid-seat both service valves.
- Install service caps on the valves.
- Energize the liquid line solenoid valve.
- After confirming that there is fresh oil in the vacuum pump, connect the 3/8" hose from the manifold to the pump.
- Start the pump and run it until the micron gauge on each evaporator unit reads 200 microns or less.
- Disconnect the vacuum pump from the system.
- Break the vacuum with R-134a refrigerant.
- Remove the micron gauge from the access valve.

### Charging

- Install a low-pressure gauge on the access valve near each evaporator unit.
- With the power off to the condensing unit, admit liquid refrigerant through the liquid line service valve until the refrigerant stops flowing.
- Turn on the circuit breaker for the condensing unit. The compressor should turn on if the pressure in the suction line is above 25 psig.
- Add refrigerant through the suction line service valve by throttling in small amounts of liquid refrigerant in two-second intervals. (Refrigerant must be throttled in or the compressor may be damaged.) Observe the sight glass. If bubbles are present, add more refrigerant until the sight glass is clear.
- Once the sight glass is clear, check the superheat at the suction line service valve. Adjust the TXV until the total superheat is between 20-30°F.
- Under normal operation, with the wine cellar at 55°F and the ambient temperature at 85°F, the low side pressure should be between 28-32 psig and the high side should be between 160-180 psig.

### Finalizing the Installation

- Confirm that the entire suction line from the TXV to the suction line service valve is insulated using cellular insulation or equivalent. Seal all seams with Armaflex 520 foam insulation adhesive or equivalent.
- Confirm that the control is displaying the correct temperature and that no alarms are present. Refer to page 45 for corrective action if alarms are present.

## INSTALLING THE WALL MOUNT KIT

1. If removed, reinstall the top panel of the unit housing.
2. Align the front grille with the four (4) ball studs on the housing. Push the front grille onto the ball studs until it snaps into place.
3. Using a Phillips-head screwdriver, fasten the bottom two (2) screws to fasten the grille to the unit.

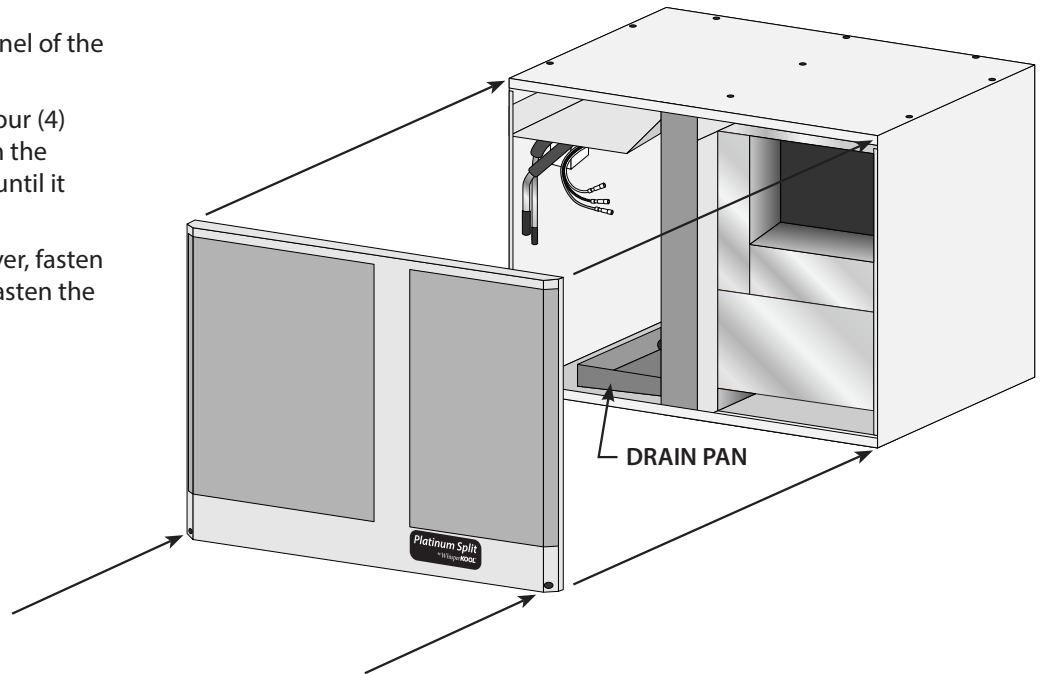

## INSTALLING THE DUCTED PLENUM

1. If removed, reinstall the top panel of the unit housing.
2. Align duct plenum with the four (4) ball studs on the housing. Push the duct plenum onto the ball studs until it snaps into place.
3. Using a Phillips-head screwdriver, fasten the bottom two (2) screws to fasten the plenum to the unit.
4. Connect the supply and return duct work to the unit.
5. Using duct tape or foil tape, seal the seam between the plenum and unit.
6. Insulate all exposed metal on the unit to prevent surface condensation.

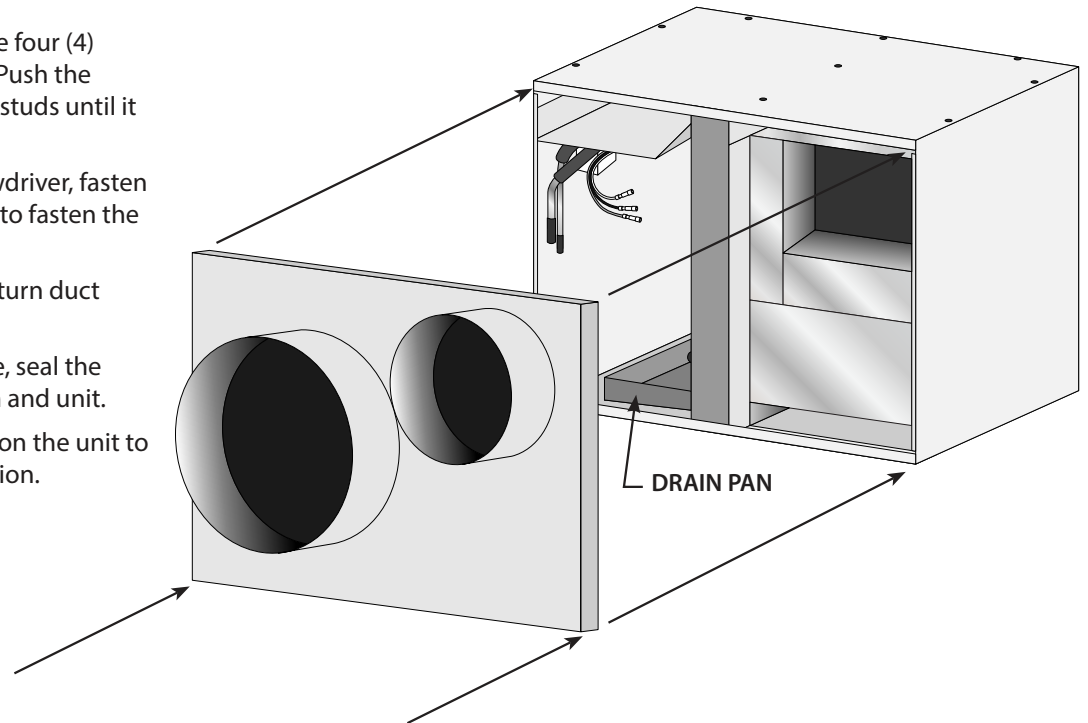

**NOTE:** Max ducting length is 25 feet per evaporator unit.

## COPELAND WIRING PROCEDURE

**Copeland Wiring Procedure** Step # 1



Use a 1/4" nut driver to remove the screws securing the cover to the compressor electrical compartment.

The image shows a close-up of the metal electrical compartment cover of a Copeland compressor. Two screws are circled in red, indicating they need to be removed. The cover has a control panel with an Emerson digital display and various buttons. A warning label is visible on the cover, and a terminal block is partially visible on the left.

**Copeland Wiring Procedure** Step # 2



Remove the cover as shown.

The image shows the same compressor unit with the electrical compartment cover removed. The internal wiring, including a terminal block with yellow, red, and blue wires, is now visible. The Emerson control panel is still present on the metal housing.



### Copeland Wiring Procedure

Step # 3

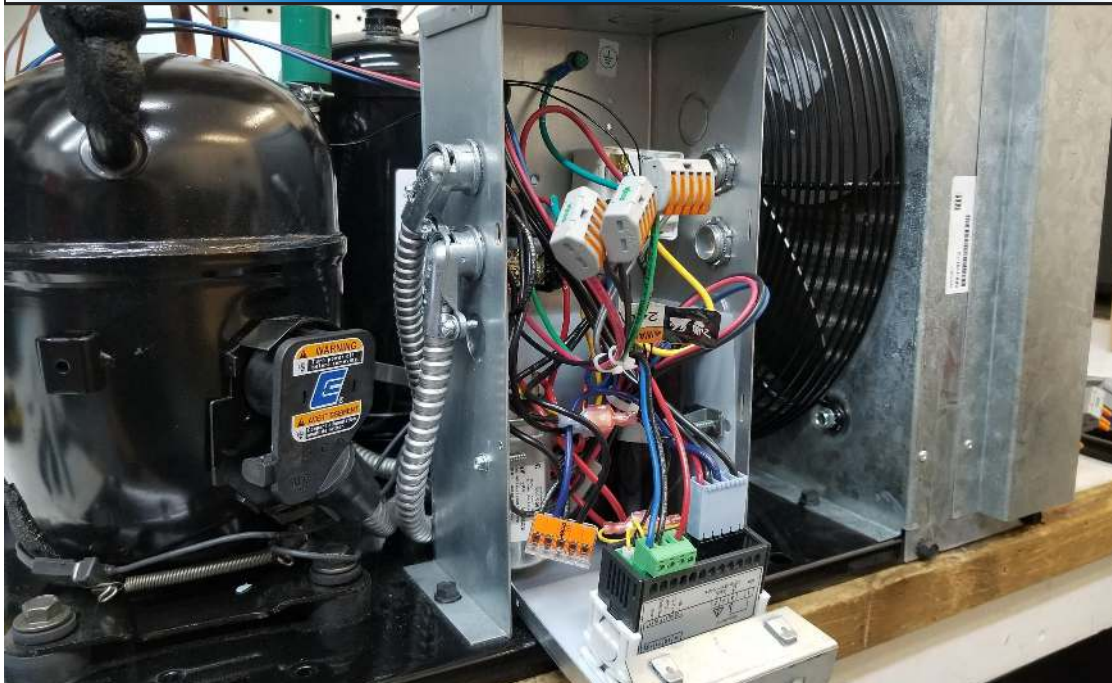

Pull the controller panel forward and rest it in the down position to expose the internal compartment.

### Copeland Wiring Procedure

Step # 4

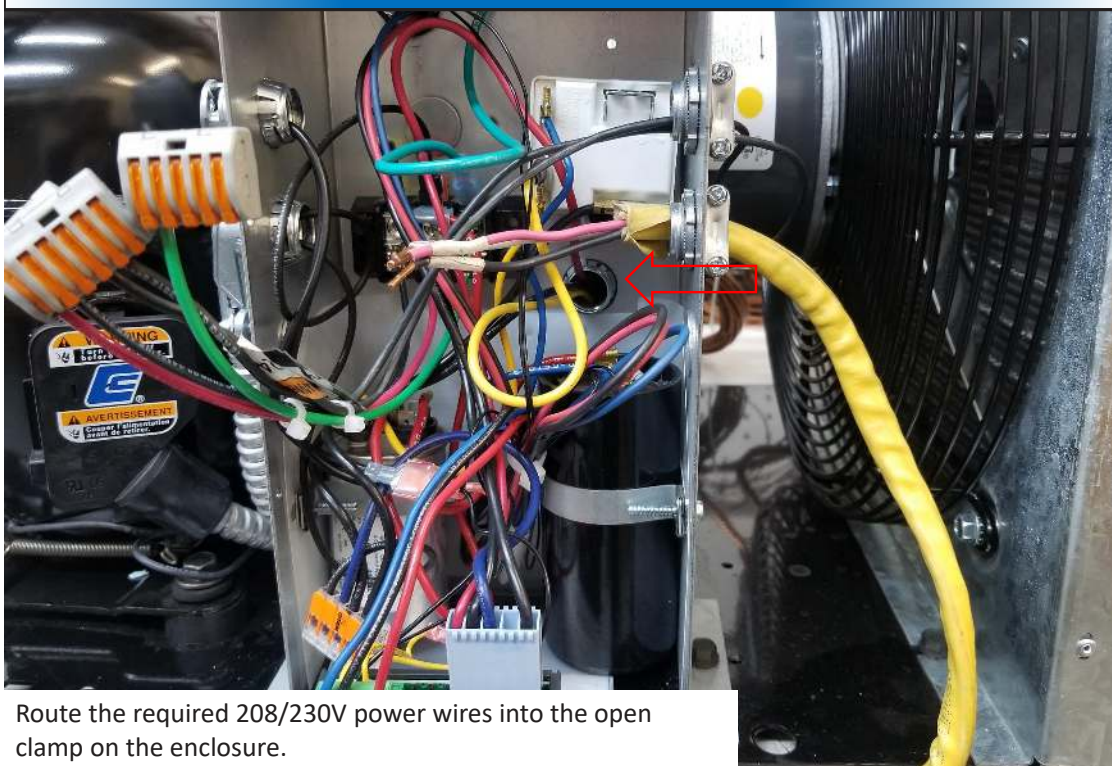

Route the required 208/230V power wires into the open clamp on the enclosure.

### Copeland Wiring Procedure

Step # 5

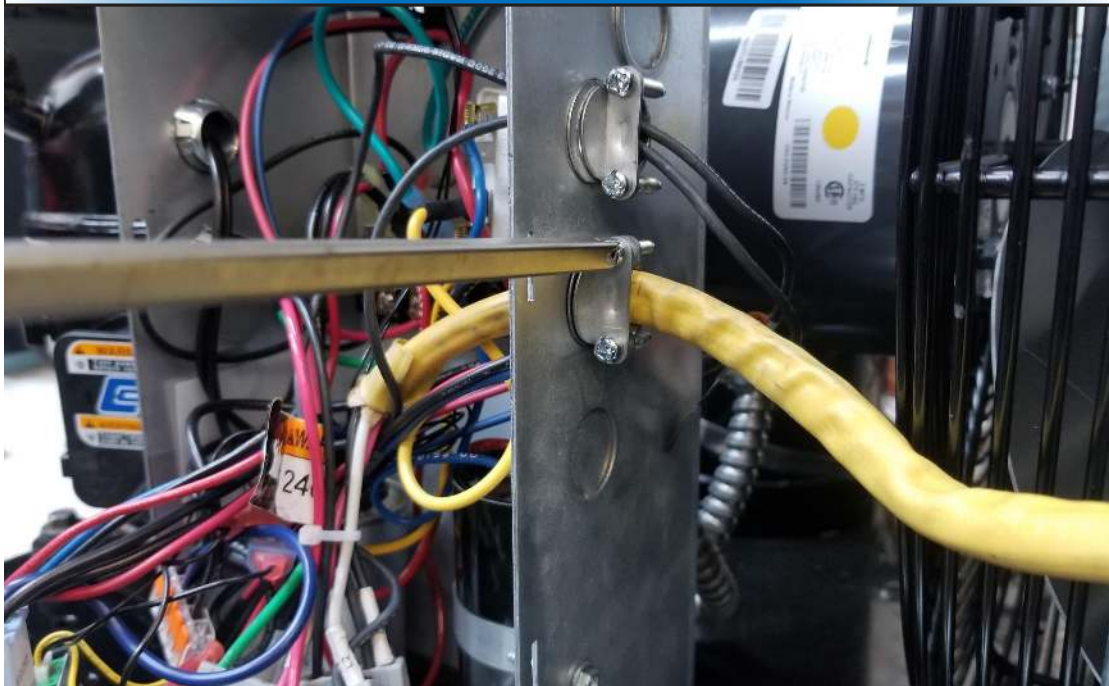

Tighten the screws on the clamp to secure wire casing or conduit in place.

### Copeland Wiring Procedure

Step # 6

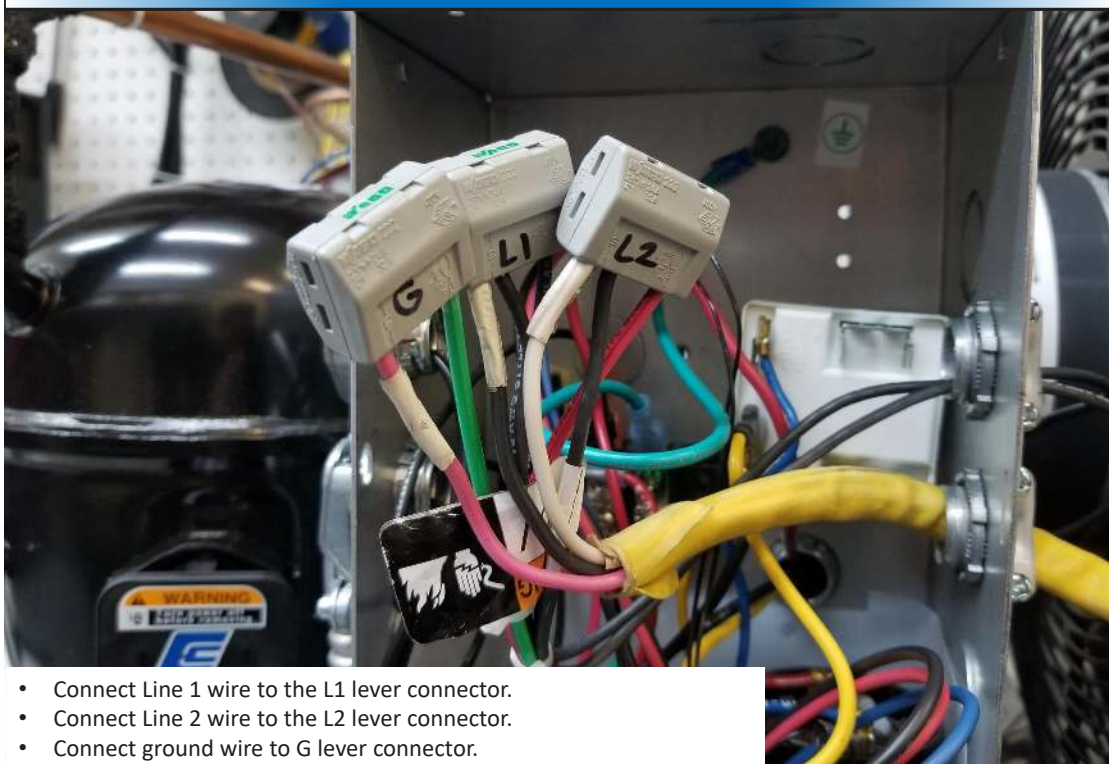

- Connect Line 1 wire to the L1 lever connector.
- Connect Line 2 wire to the L2 lever connector.
- Connect ground wire to G lever connector.







## SYSTEM OPERATION

### Initial Start-Up

When the unit is plugged in and power is sent to the controller, a beep will sound, confirming that the controller is getting power. All LEDs on the display will blink three times. Three dashes will then appear on the screen. All display LEDs will then blink three times. Once the controller has gone through the initial startup process, and all LEDs have cycled, the home screen will be displayed.

### Setpoint

The setpoint is preset at the factory to 55°F. It can be adjusted by the customer between 50–70°F in one-degree increments.

### Indoor Fan Operation

The indoor fan will run when the controller is calling for cooling and turn off once the cooling cycle has ended. During the cooling cycle, the system will remove some relative humidity from the cellar. Some of the humidity that was removed can be reintroduced into the cellar by adjusting the “fan on” and “fan off” functions. (The cooling system is not equipped with a humidifier and does not add humidity.)

The FOF cycle should be shortened first. This will reduce the amount of time that the fan remains off following a cooling cycle. When the unit has completed a cooling cycle, the compressor and the condenser fan will turn off, but the indoor fan will continue to run for whatever length of time the customer has set. The Fon function may then be lengthened to allow the fan to run longer and reintroduce moisture from the evaporator coil back into the wine cellar.

For more information about fan settings, refer to the User Menu on page 47.

### Anti-Short Cycle

The Anti-Short Cycle ensures that the unit will remain off for a period of five minutes after the unit has reached the setpoint. This allows the pressure in the refrigeration system to equalize prior to starting the compressor.

Once the solenoid relay is de-energized, the controller must wait five minutes before reenergizing the relay. This prevents the compressor from repeatedly turning off and on. If the unit is calling for cooling during this time, the compressor icon will blink, indicating that cooling is needed but the controller is waiting for the Anti-Short Cycle delay.

### Anti-Frost Cycle

When the evaporator probe senses a temperature of 26°F for a duration of one minute, an Anti-Frost Cycle will be initiated. This will shut down the compressor, allowing the evaporator fan to run and melt any frost accumulation on the coil. While the Anti-Frost Cycle is running, “dEF” will be displayed on the screen.

The compressor will remain off until the evaporator coil reaches 40°F, or for a maximum of one hour. The unit will then return to normal operation.

### Operation in Low Ambient Temperatures

The condensing unit comes equipped with a LAC (Low Ambient Control). The LAC is a three-way modulating valve that responds to discharge pressure. When the discharge pressure falls below the valve’s dome pressure, the valve modulates open to the discharge port which allows discharge gas to bypass the condenser. Mixing the discharge gas with the liquid creates high pressure at the condenser outlet, reducing the flow and causing liquid to backup in the condenser. Flooding the condenser reduces the area available for condensing. This reduction in condenser surface area results in a rise in condensing pressure during cold ambient conditions.

The condensing unit controller is preset at the factory. The cut-in pressure is preset to 25psi and the cut-out pressure at 15psi. During low ambient temperatures (40°F or below), it will be necessary to adjust the cut-in pressure to 10-15psi (15psi is preferred) and the cut-out to 5psi to ensure compressor startup. See page 48 for instructions on adjusting the cut-in and cut-out pressures of the condensing unit.

### Digital Display

The display is designed to give the user the ability to adjust the setpoint, Fon/FOF parameters, and other settings. (See User Menu on page 47 for more details.) The bottle probe temperature is displayed by default. “dEF” will be displayed during an Anti-Frost Cycle. The bottle probe and evaporator probe temperatures can be accessed by pushing the SET button and scrolling through “Pb1” (bottle probe) and “Pb2” (evaporator probe). The light button may be used as an unlock button.

### Safety Features

In the event of a faulty bottle probe, the compressor will cycle off for 10 minutes and on for 40 minutes. “E1” will be displayed on the screen.

### Alarms

See “Alarm Codes” in the Controller Functions chart.

# DISPLAY LAYOUT

❄️ Compressor is on      📡 Alarm is present  
🌀 Fan is on  
❄️ Anti-Frost Cycle running



Return to Previous Menu

View/Change Setpoint  
Enter User Menu  
*(hold for 3 sec)*





Power On/Off

Scroll Button  
Change Setpoint





Scroll Button  
Change Setpoint

Unlock Button  
*(hold for 1 sec)*



## CONTROLLER FUNCTIONS

Button	Normal Functions								
<b>INITIAL STARTUP</b>	When the unit is plugged in and power is sent to the controller, a beep will sound, confirming that the controller is getting power. All LEDs on the display will blink three times. Three dashes will then appear on the screen. All display LEDs will then blink three times. Once the controller has gone through the initial startup process, and all LEDs have cycled, the home screen will be displayed.								
<b>UNLOCKING THE DISPLAY</b>	Press and hold any button for one second to unlock the display. (A white LED will appear in the top left corner of the button being pressed.) A beep will sound, signifying that the display is unlocked. <b>NOTE:</b> The display must be unlocked before any button functions become available.								
<b>ON/OFF</b> 	To turn the unit ON, press and hold the ON/OFF button until the red LED turns OFF.  To turn the unit OFF, press and hold the ON/OFF button until the red LED turns ON.								
<b>UP/DOWN</b> 	The up and down arrows are used to navigate through menus and adjust parameters such as setpoint, Fon/FOF, etc.								
<b>SET</b> 	<ul style="list-style-type: none"> <li>To change the setpoint, press the SET button. When "SEt" is displayed on the screen, press the SET button once more. Use the UP and DOWN ARROW buttons in order to change the value until the desired setpoint is reached.</li> <li>The SET button allows you to view the setpoint, evaporator temperature, bottle temperature, alarms, and the hidden menu.</li> <li>Press the SET button once. "SEt" will be displayed. Press the UP or DOWN ARROW buttons to scroll through ALr, Pb1, or Pb2.</li> </ul> <table border="1"> <thead> <tr> <th>Set</th> <th>Setpoint</th> </tr> </thead> <tbody> <tr> <td><b>ALr</b></td> <td>Alarm folder</td> </tr> <tr> <td><b>Pb1</b></td> <td>Liquid (bottle probe) temperature</td> </tr> <tr> <td><b>Pb2</b></td> <td>Evaporator coil temperature</td> </tr> </tbody> </table> <ul style="list-style-type: none"> <li>Press the SET button again to view any of these values.</li> <li>Hold the SET button for approximately 5 seconds to enter the User Menu. (More information about the User Menu is available on page 47.)</li> <li>Other parameters in the User Menu which are not available for adjustment include: idF, rEL, and LAN.</li> </ul>	Set	Setpoint	<b>ALr</b>	Alarm folder	<b>Pb1</b>	Liquid (bottle probe) temperature	<b>Pb2</b>	Evaporator coil temperature
Set	Setpoint								
<b>ALr</b>	Alarm folder								
<b>Pb1</b>	Liquid (bottle probe) temperature								
<b>Pb2</b>	Evaporator coil temperature								
<b>ESC</b> 	This button confirms changes made to parameters such as the setpoint and returns you to the previous menu.								
<b>LIGHT</b> 	The light function is not in use. However, this button can still be used to unlock the display.								

## ICON GLOSSARY

Icon	Meaning
<b>SNOWFLAKE</b> 	<p><b>Blinking:</b> The unit is calling for cooling, but must wait five minutes before restarting the compressor. This five-minute delay serves as an Anti-Short Cycle for the compressor's protection.</p> <p><b>Constant:</b> The unit is in cooling mode and the condensing unit is running.</p>
<b>DRIPPING SNOWFLAKE</b> 	<p>The unit is undergoing an Anti-Frost Cycle. While the Anti-Frost Cycle is running, "dEF" will be displayed on the screen. See System Operation page for further details.</p>
<b>FAN</b> 	<p>The evaporator fan is running.</p>
<b>ALARM</b> 	<p>The alarm icon is shown when the unit encounters an issue that needs attention. Alarm codes are explained on the following page. All temperature-related alarms are blocked for the first 10 hours after the unit is plugged in to allow the system to stabilize and acclimate to the new environment.</p>

## ALARM CODES

Code	Cause	Solution
<b>The following alarm codes will be displayed on the screen along with the alarm icon. </b>		
<b>E1</b>	Bottle probe is not connected	Attach bottle probe to circular connector
	Faulty bottle probe connection	Locate faulty bottle probe connection by inspecting all wiring connections between the bottle probe and the circuit board. The two-pin connector for the bottle probe should be connected to the CPB/PB1 terminal on the circuit board. If it is not connected, plug it in. If a faulty connection has been identified, correct the issue or contact customer service for further assistance.  <b>NOTE:</b> The E1 code will not appear in the alarms menu. It will be permanently displayed on the screen.
	Defective bottle probe	Replace the bottle probe
<b>E2</b>	Faulty evaporator probe connection	Locate faulty evaporator probe connection by inspecting evaporator probe wire. The two-pin connector for the evaporator probe should be connected to the CPB/PB2 terminal on the circuit board. If it is not connected, plug it in.
	Defective evaporator probe	Replace the evaporator probe
<b>E7</b>	No communication between keypad and circuit board for 60 seconds	Verify that the display cable is connected to the keypad and the circuit board and is not damaged, frayed, or kinked. If problem persists, contact Customer Service for troubleshooting information.
<b>E10</b>	Clock battery is dead	Replace battery  <b>NOTE:</b> A dead clock battery will not affect the operation of your cooling unit.
<b>The following alarm codes will not be displayed on the home screen. However, the alarm icon will be displayed in the event of an alarm. The alarms can be viewed in the Set Menu's ALr folder. </b>		
<b>EA</b>	Unit is not draining properly	1. Check to see that the unit is level; if not, level it 2. Verify that the drain line is not clogged; if so, clear obstruction 3. Ensure that the condensate pump is operating  <b>NOTE:</b> If the drain line is obstructed or the pump fails for some reason, and the water level in the drip tray gets too high, the unit will not operate until the water in the internal drip tray drops back below the proper level.
<b>AH1</b>	The bottle probe is sensing a temperature that is 8°F above the setpoint	1. Allow time for the wine to reach the desired temperature 2. Ensure that the cellar is sealed properly 3. Verify that the bottle probe is calibrated correctly (refer to the User Menu on the following page) 4. Verify that the unit is sized correctly for the cellar
<b>AL1</b>	The bottle probe is sensing a temperature that is 8°F below the setpoint	1. Make sure the unit is not in cooling mode (the snowflake icon will not be illuminated) 2. Add heat to the room until the wine reaches the desired temp 3. Verify that the bottle probe is calibrated correctly (refer to the User Menu on the following page)
<b>Ad2</b>	The Anti-Frost Cycle ended on time-out	1. Check the evaporator coil for ice buildup. Unplug the unit and allow the coil to thaw before restarting. 2. Make sure the room to which the unit is exhausting is not below 60°F 3. If the unit repeatedly goes into Anti-Frost Cycles (one per minute), call Customer Service for more troubleshooting information

## USER MENU

The User Menu is accessed by **pressing and holding the SET button for 3 seconds**. Use the UP and DOWN ARROW buttons to navigate to desired parameters. Press the SET button again to view these parameters. Press the UP and DOWN ARROW buttons to adjust a parameter.

The following parameters are available in the menu:

Parameter	Description
<b>Fdc - humidity enhancement</b>	This parameter is measured in minutes, and is preset at the factory to 1. An increase in this parameter will increase the humidity enhancement of your cellar. This parameter should not be adjusted to zero. Adjustments should be made in increments of 5, with a maximum of 15 and a minimum of 1. After making any adjustments to humidity enhancement, <b>you should wait a minimum of 3 days</b> before making any additional adjustments. This will allow sufficient time for the cellar to acclimate to the new setting.
<b>FOF - "fan off"</b>	This setting controls how long the fan stays off after the setpoint has been reached. It is preset to 15 minutes. This setting should not be adjusted, as most properly constructed wine cellars retain an ample amount of humidity during the "fan off" cycle. If, however, you wish to decrease the duration of the "fan off" cycle (in order to increase the wine cellar's relative humidity), you can adjust this setting in the User Menu.
<b>Fon - "fan on"</b>	The "fan on" time is preset to zero minutes. This keeps the relative humidity of the wine cellar at a stable level. If, however, you wish to raise the relative humidity of your wine cellar, you can increase the duration of the "fan on" cycle in increments of five (5, 10, or 15 minutes). After making any adjustment to the "fan on" cycle, <b>you should wait a minimum of 3 days</b> before making any additional adjustments. This will allow sufficient time for the cellar to acclimate to the new setting.
<b>CA1 - bottle probe (Pb1) calibration</b>	<b>CA1 - bottle probe (Pb1) calibration:</b> You may use this parameter to calibrate the bottle probe to a known temperature. This parameter can be adjusted between -12°F and 12°F. For example, if the bottle probe temperature is 58°F, and the known temperature is 55°F, you can set the CA1 parameter to -3°F to match the known temperature.
<b>PA2 - installer menu</b>	This menu is only accessible using a password and is not available for adjustment.
<b>dOA - digital input</b>	This setting determines which of the unit's components will be activated or deactivated when a certain electrical relay is activated or deactivated in response to an alarm. The controller comes pre-programmed with a factory setting of 2.  2 = activates the compressor and fans 5 = disables the compressor and fans  <b>NOTE:</b> Setting the dOA to any number other than 2 or 5 will prevent the unit from operating properly.

# Emerson<sup>™</sup> Electronic Unit Controller

## Quick setup and troubleshooting guide

### Adjusting Low Pressure Settings

- Hold DOWN and SET simultaneously for 3 seconds to enter menu (PSI light will flash) ▼ + SET
- Cycle through menu options – UP/DOWN ▲ ▼
- Select function – SET SET
- Adjust value – UP/DOWN ▲ ▼
- Store function - SET SET
- Exit menu - UP and SET ▲ + SET



Low Pressure Cut-In



Low Pressure Cut-Out

### Accessing Alarm Code Information

- Press and release ALARM 📖
- Cycle through menu options – UP/DOWN ▲ ▼
- Press SET to see number of alarms SET
- Press SET again to return to menu options SET
- Exit menu - UP and SET ▲ + SET

Alarm	Description
PoF	Keypad locked
Pon	Keypad unlocked
P1	Suction probe failure
P2	Condenser probe failure
P3	DLT probe failure
HA	High condenser temperature alarm
dLt	DLT temperature alarm
dLL	DLT lock alarm
HP	High pressure trip alarm
HPL	High pressure trip lock-out alarm
EE	Module Failure
LOC	Number of lock-outs

Note: After 15 seconds of inactivity the controller will revert to the default display.

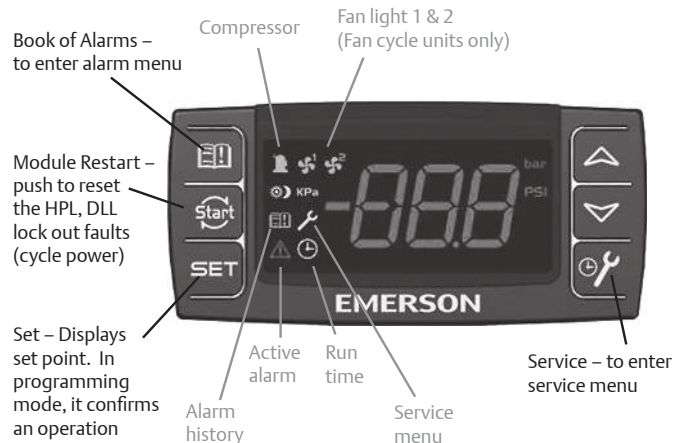

When light is on, feature or component is on or active

### Accessing Service Menu

- Hold SERVICE for 3 seconds 🔧
- Cycle through menu options – UP/DOWN ▲ ▼
- Press SET to see number of alarms SET
- Press SET again to return to menu options SET
- Exit menu - UP and SET ▲ + SET

Code	Description
StH	CompressorStarts -1000 -999999
StL	Compressor Starts -0 -999
CHH	CompressorHours -1000 -999999
CHL	Compressor Hours -0 -999
F1H	Fan 1 Hours -1000 -999999
F1L	Fan 1 Hours-0 -999
F2H	Fan 2 Hours -1000 -999999
F2L	Fan 2 Hours -0 -999

Example: If StH=12 and StL=500, the total number of compressor starts=12,500

For more information visit [EmersonClimate.com/ElectronicUnitController](http://EmersonClimate.com/ElectronicUnitController) or call 1-888-367-9950



Display	Likely Causes	Other Possible Causes
Controller display remains blank after applying power	<ul style="list-style-type: none"> <li>Unit power not properly applied - check for proper applied voltage</li> <li>Power cable harness not plugged in properly or securely into the back of the controller – check connections</li> </ul>	<ul style="list-style-type: none"> <li>Power cable miswired – inspect cable, replace if needed</li> <li>Electrical assembly miswired – trace wiring diagrams</li> </ul>
Controller displays correctly, but the green compressor light is off and the compressor is not running	<ul style="list-style-type: none"> <li>Jumper cable not plugged in properly or securely into the back of the controller – check connections</li> <li>Controller is currently above the cut-in setting – check cut-in and cut-out settings</li> </ul>	<ul style="list-style-type: none"> <li>Jumper cable miswired – inspect cable, replace if needed</li> </ul>
Controller displays correctly and the green compressor light is on and the compressor is not running	<ul style="list-style-type: none"> <li>Power cable harness not plugged in properly or securely into the back of the controller – check connections</li> </ul>	<ul style="list-style-type: none"> <li>Power cable not wired to the contactor or compressor correctly, check wiring</li> <li>Power cable miswired – inspect cable, replace if needed</li> </ul>
Controller flashes “135” or “P1”	<ul style="list-style-type: none"> <li>Current system pressure is above 135 PSIG – wait for system to pull down</li> <li>Green harness not plugged in properly or securely into the back of the controller – check connections</li> <li>Cable not connected properly with the pressure transducer – check connections</li> </ul>	<ul style="list-style-type: none"> <li>Transducer cable miswired – inspect cable, replace if needed</li> <li>Damaged transducer – inspect transducer, replace if needed</li> </ul>
Controller flashes “P2” on a unit with fan cycling	<ul style="list-style-type: none"> <li>Green harness not plugged in properly or securely into the back of the controller – check connections</li> </ul>	<ul style="list-style-type: none"> <li>Transducer cable miswired – inspect cable, replace if needed</li> <li>Check condenser temperature sensor resistance values against table in AE-1376, Section 8</li> </ul>
Controller flashes “P2” on a unit without fan cycling after replacing a controller	<ul style="list-style-type: none"> <li>Controller not programmed properly – check parameters in the advanced menu</li> </ul>	
Controller flashes “P3” on a unit with DLT	<ul style="list-style-type: none"> <li>Jumper cable not plugged in properly or securely into the back of the controller – check connections</li> </ul>	<ul style="list-style-type: none"> <li>Jumper cable miswired – inspect cable, replace if needed</li> <li>Faulty DLT temperature sensor – check the discharge line temperature sensor resistance values against table in AE-1376, Section 8</li> </ul>
Controller flashes “P3” on a unit without DLT after replacing a controller	<ul style="list-style-type: none"> <li>Controller not programmed properly – check parameters in the advanced menu</li> </ul>	
Fans not running on a fan cycling unit and the fan lights are not on	<ul style="list-style-type: none"> <li>Condensing temperature is currently below the fan cut-in</li> <li>Condensing temperature sensor not properly installed – check installation</li> </ul>	<ul style="list-style-type: none"> <li>Transducer cable miswired – inspect cable, replace if needed</li> <li>Faulty temperature sensor - check condenser temperature sensor resistance values against table in AE-1376, Section 8</li> </ul>
Fans not running on a fan cycling unit and the fan lights are on	<ul style="list-style-type: none"> <li>Power cable harness not plugged in properly or securely into the back of the controller – check connections</li> </ul>	<ul style="list-style-type: none"> <li>Power cable miswired – inspect cable, replace if needed</li> <li>Electrical assembly miswired – trace wiring diagrams</li> </ul>
Controller flashes “HP” at power-up	<ul style="list-style-type: none"> <li>Jumper cable not plugged in properly or securely into the back of the controller – check connections</li> <li>High pressure switch is seeing above the cut-out pressure</li> <li>For a replacing an -00 controller, ensure that the jumper cable is the latest revision. It should have a blue wire in the harness. See replacement instructions for more details</li> </ul>	<ul style="list-style-type: none"> <li>Jumper cable miswired – inspect cable, replace if needed</li> <li>Faulty fixed Hp switch – inspect switch, replace if needed</li> </ul>
Controller flashes “HP” or “HPL”	<ul style="list-style-type: none"> <li>System operation causing high discharge pressures, check system operations</li> </ul>	<ul style="list-style-type: none"> <li>Bad high pressure switch, verify system pressure when the pressure switch trips.</li> <li>See AE-1376, Section 7.2 for more details</li> </ul>
Controller flashes “DLT” or “DLL”	<ul style="list-style-type: none"> <li>System operation causing high discharge line temperatures, check system operations</li> </ul>	<ul style="list-style-type: none"> <li>Faulty temperature sensor - check DLT sensor values against table in section 8</li> <li>See AE-1376, Section 7.1 for more details</li> </ul>
Controller flashing “HPL” or “DLL”	<ul style="list-style-type: none"> <li>System operation causing high discharge pressures (HPL) or high discharge line temperatures (DLL) repeatedly, check system operations</li> <li>To clear an “HPL” or “DLL” lockout, you can hold the Restart button for 3 seconds twice, or cycle power to the unit. If using the reset button, the alarm condition will have to clear (DLT temperature drops or Hp switch resets), and any minimum off time will need to complete (5 minutes for the fixed Hp switch)</li> </ul>	

## EmersonClimate.com/ElectronicUnitController

2013ECT-46 (9/13) Emerson is a trademark of Emerson Electric Co. ©2013 Emerson Climate Technologies, Inc. All rights reserved.

EMERSON. CONSIDER IT SOLVED.™



## WHISPERKOOL TROUBLESHOOTING GUIDE

<b>Ice forming on the evaporator units</b>	
<b>Possible cause</b>	<b>Solution</b>
Evaporator filters or coils are dirty	Remove the filters and wash them, then clean the coils with a vacuum. If coils are very dirty, use a spray bottle with a small amount of liquid dish detergent or coil cleaner. Spray coils, let set for five minutes, then flush with fresh water.
There is something blocking the supply and/or return air	Remove blockage
The evaporator fans are not turning on	Call a service tech to troubleshoot
The evaporator units have not gone through an Anti-Frost Cycle yet	Check the coils for surface ice. Melt with blow drier until coils are warm to the touch. Soak up water with a towel.
If evaporator units continue to ice	Observe ice formation pattern. If only part way up the coil face, the system could be low on refrigerant. If all the way up, the coils may be dirty or airflow is blocked.
<b>System does not run/power up</b>	
<b>Possible cause</b>	<b>Solution</b>
Evaporator units are not plugged in	Make sure the units are plugged into an outlet
Power switch not on	Turn unit on by pressing the power button on the control
Line voltage rating is incorrect for the system	Check line voltage to make sure there is 110V-120V
Bottle at setpoint	Lower setpoint
Thermostat not calling for cooling	Lower setpoint
Faulty thermostat or wiring	Contact WhisperKool customer service
<b>Cellar temperature is too warm</b>	
<b>Possible cause</b>	<b>Solution</b>
The temperature of the room to which the condensing unit exhausts exceeds 110°F	Intake temperature needs to drop below 110°F
The system is undersized for the cellar	Order correctly sized system
There is something blocking the supply and/or return air on the evaporator units or the condensing unit	Remove airflow obstruction
Evaporator units are mounted too low in the cellar	Relocate units so the distance from the ceiling and top of the unit is no more than 18"
One or more of the fans is not turning on	Please contact the installing technician to troubleshoot
Compressor is not turning on	Please contact the installing technician to troubleshoot
Compressor keeps cycling on overload	Make sure all fans are working and there is no airflow obstruction
Poor seal around door or other areas requiring a seal (around the unit, wall joints, etc.)	Make sure there are no air gaps around the door. If door seal is damaged, replace it.
Setpoint too high	Lower the setpoint
Evaporator coils are frosted or iced up	Observe ice formation pattern. If only part way up the coil face, the system could be low on refrigerant. If so, contact your installing technician to assist with troubleshooting.
<b>System runs constantly</b>	
<b>Possible cause</b>	<b>Solution</b>
Leaky door seal or poorly insulated cellar	Fix leaky door seal and insulate cellar

<b>Units leak water</b>	
<b>Possible cause</b>	<b>Solution</b>
Evaporator units are not level	Evaporator units should be level on the wall to prevent leaking
Drain lines are clogged or kinked	Check drain lines to make sure water can flow freely
Drains are clogged, preventing water from escaping	Disconnect drain lines and clear them out; check drains for blockage
Drain lines do not have a downward slope	Fix drain lines so there is a downward slope from the unit to the drains
Coils are iced, causing drain pans to freeze and water to overflow	Melt ice with blow drier. Soak up water with a towel.
<b>System runs but does not cool</b>	
<b>Possible cause</b>	<b>Solution</b>
Lack of airflow	Make sure fans are unobstructed and that the evaporator filter, evaporator coil, and condenser coil are clean and free of debris
System undersized	Contact WhisperKool customer service
Compressor is overheating	Shut system off for 1 hour to allow compressor to cool. Turn back on and check for cooler air flow out. If compressor runs, check for and clean condenser coil as possible cause of compressor overheating. If problem repeats, contact your installing technician to assist with troubleshooting.
<b>Evaporator fans run but compressor does not</b>	
<b>Possible cause</b>	<b>Solution</b>
Running an Anti-Frost Cycle	1) If the system is maintaining the correct cellar temperature and there is a dripping snowflake symbol illuminated on the control, the system is going through an Anti-Frost Cycle. No action is required. 2) If the system is not maintaining the correct cellar temperature, this may be due to dirty evaporator filters or coils. 3) Call installing technician to troubleshoot, as the system may be low on charge or require an adjustment to the TXV.
Compressor and/or starting components faulty	Please contact the installing technician to troubleshoot
System may be performing the WHM function	Allow cooling system to revert back to cooling mode
Compressor may have overheated	Shut system off for 1 hour to allow compressor to cool. Turn back on and check for cooler air flow out. If compressor runs, check for and clean condenser coil as possible cause of compressor overheating. If problem repeats, contact your installing technician to assist with troubleshooting.
<b>Compressor runs but evaporator fan does not</b>	
<b>Possible cause</b>	<b>Solution</b>
Faulty fan motor	Please contact the installing technician to troubleshoot
Faulty controller	Please contact the installing technician to troubleshoot
<b>Compressor short cycles</b>	
<b>Possible cause</b>	<b>Solution</b>
Evaporator units blow on bottle probe	Move bottle probe to a more central location
System low on refrigerant charge	Please contact the installing technician to troubleshoot
Condensing fan motor/capacitor faulty	Please contact the installing technician to troubleshoot
Compressor and /or starting components faulty	Please contact the installing technician to troubleshoot
<b>Humidity in cellar too low</b>	
<b>Possible cause</b>	<b>Solution</b>
Not enough moisture	Purchase and place a humidifier (or a decorative fountain) in cellar

## MAINTENANCE SCHEDULE

<b>Monthly</b>	<ol style="list-style-type: none"><li>1. Check coils</li><li>2. Check for unusual noise or vibration</li><li>3. Check the drain lines to see if they are above the waterline (if draining into a vessel)</li></ol>
<b>Quarterly</b>	<ol style="list-style-type: none"><li>1. Use a vacuum with brush attachment to clean coils; be careful not to crush coil fins when cleaning</li><li>2. Change duct filters if the system is ducted</li></ol>
<b>Annually</b>	<ol style="list-style-type: none"><li>1. Inspect for corrosion</li><li>2. Check wiring connections and integrity of cords</li><li>3. Pour a 50/50 bleach solution into the drain lines every spring</li></ol>

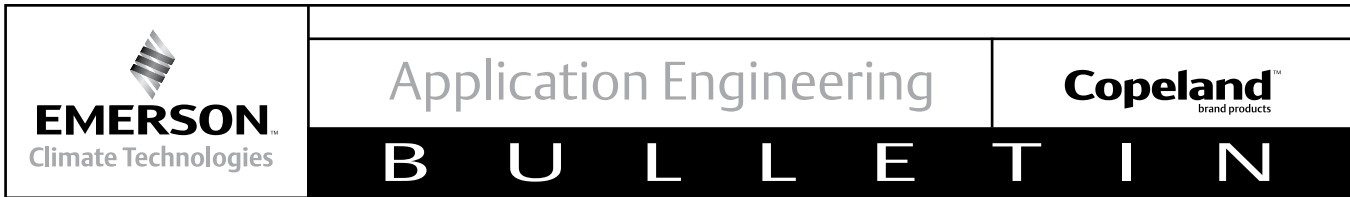

AE5-1340

October 2006

## Care and Cleaning of Air Cooled Condensing Units

### Introduction

Proper care is essential to assure good life of condensing units. Dirty or damaged condensers will reduce the efficiency and capacity of the system.

Care must be taken in choosing solutions to be used for cleaning condensers and condensate pans. Chlorinated cleaners and anti-bacterial cleaning agents can be damaging and should be avoided. Caustic and acidic cleaners should be avoided as well. Failure to do so may accelerate component corrosion and ultimately lead to component failure.

### Condenser Coils

There are many commercially available condenser coil cleaners on the market. Coil cleaners should be designed to remove build-up on fins and coils. Coils should be thoroughly rinsed of the cleaners once cleaning has been completed. Follow the manufacturer's instruction for proper usage. Preventive maintenance and routine cleaning of coils is important to assure good life.

When cleaning the coil, an absorbent type material should be placed under the area to be cleaned in order to capture most of the cleaning compound, thus minimizing any type of chemical attack.

### Condensate Pans

Condensing units with condensate pans and condensate tubes are designed to evaporate condensate water only. Other ingredients introduced into the condensate pan can accelerate pan and/or tube corrosion. As foreign agents are introduced into the condensate pan, condensate water will be evaporated leaving the foreign agent behind. This can lead to a high concentration of the agent and possible corrosion of the tubing and/or base.

Coil cleaning agents must not be allowed to drain into the condensate pan as this may cause damage. Upon completing the coil cleaning, be certain that all residue is removed from the condensate pan.

Only non corrosive cleaners should be used to assure good life of the condensing unit components. No hydrocarbon based cleaners should be used to clean the unit. Bleach solutions must be avoided due to its high corrosive nature.

Under no circumstances should cleaning agent ingredients contain any of the solutions listed below:

### Unacceptable solutions are:

- Chlorinated Solvents**
- Bleaches**
- Vinegar**
- Ammonia**
- Anti-Bacterials**
- Salts**

### Preventative Maintenance

Maintenance should be performed at regular intervals. Coils should be cleaned at least monthly, possibly more depending on the environment. Condensing units with condensate pans should also be checked and cleaned regularly to prevent damaging build up in the pan.

### Safety

Please follow all safety recommendations listed by the manufacturer of the cleaning agent(s), these would include proper clothing, gloves and eye protection.

## **BYPASS TEST PROCEDURE**

**NOTE:** If instructed by a WhisperKOOL representative, follow the directions below to test the cooling unit using the bypass plug provided in the accessory kit.

1. Disconnect power from the evaporator units.
2. Loosen the two (2) screws on the front of the grille or duct plenum.
3. Pull the grille or duct plenum away from the evaporator units.
4. Remove the screw securing the control panel in place.
5. Slide the control panel down, out of the evaporator housing. The control panel has two (2) hooks which allow it to attach to the evaporator units for easy serviceability.
6. Disconnect the Molex connector labeled #4.
7. Locate the bypass plug included in the accessory kit.
8. Plug the bypass plug into the male Molex connector.
9. Connect power to the evaporator units. The system should immediately turn on. If all the components are not operational, disconnect power immediately and contact customer service. If all components seem to be operating correctly, allow the system to run for four (4) hours. Monitor the temperature of the cellar to determine if the system is cooling properly.
10. Once the test is complete, remove the bypass plug. Plug the Molex connector back in to the system's wiring.
11. Replace the control and faceplate.

# TECHNICAL ASSISTANCE

WhisperKOOL Customer Service is available Monday through Friday from 6:00 a.m. to 4:00 p.m. Pacific Standard Time.

The appointed customer service representative will be able to assist you with your questions and warranty information more effectively if you provide them with the following:

- The model and serial number of your WhisperKOOL system(s).
- Location of unit and installation details, such as ventilation, ducting, construction of your wine cellar, and room size.
- Photos of the cellar and installation location may be needed.

## Contact WhisperKOOL Customer Service

1738 E. Alpine Ave  
Stockton, CA, 95205  
[www.whisperkool.com](http://www.whisperkool.com)

**Email:** [support@whisperkool.com](mailto:support@whisperkool.com)

**Fax:** 209-466-4606

Visit [www.emersonclimate.com/electronicunitcontroller](http://www.emersonclimate.com/electronicunitcontroller) for online brochures, bulletins, instruction videos, and general product information.

**Download the Copeland Mobile App on your mobile device for additional troubleshooting and technical information.**



## ACCESSORIES FOR COOLING UNITS

WhisperKOOL offers accessories to enhance and customize your wine cooling unit:

### UV Air Purification Upgrade

The optional UV air purification kit provides chemical-free cleaning of the air from germs and microbes, inhibits the growth of mold and bacteria inside the cooling system, and optimizes system performance and longevity.

### Condensate Pump Kit

The condensate pump kit automatically removes water that drips out of the evaporator unit's drain line. The pump is controlled by a float/switch mechanism that turns the pump on when approximately 2¼" of water collects in the tank, and automatically switches off when the tank drains to approximately 1¼". The condensate pump kit allows the excess condensate to be pumped up to 20 feet away from the unit.

### Exterior Housing

If the cooling unit is installed outside, it will need protection from sun, wind, and rain. The exterior housing protects the condensing unit portion of the split system from the elements when installed outdoors.

**Accessories can be purchased at [www.whisperkool.com](http://www.whisperkool.com)**

**WhisperKOOL Product Terms and Conditions**  
**Including Product Limited Warranty And Product Installation Requirements**  
**For WhisperKOOL Split System Series**

ATTENTION: PLEASE READ THESE TERMS OF USE CAREFULLY BEFORE INSTALLING YOUR WHISPERKOOL COOLING SYSTEM. INSTALLING YOUR WHISPERKOOL COOLING SYSTEM INDICATES THAT YOU ACCEPT AND AGREE TO EACH OF THE TERMS AND CONDITIONS SET FORTH HEREIN ("TERMS OF USE"). IF YOU DO NOT ACCEPT THESE TERMS OF USE, YOU RISK VOIDING YOUR WARRANTY AND ASSUMING ADDITIONAL REPAIR AND REPLACEMENT COSTS.

**1. Purchase of a WhisperKOOL Cooling System assumes that the Purchaser ("End User") fully accepts and agrees to the Terms and Conditions set forth in this document. The Terms and Conditions of Sale and Owner's Manual are shipped with each unit and, if another copy is needed, replacement copies can be downloaded from the company website (whisperkool.com) or by contacting WhisperKOOL directly for a new copy. WhisperKOOL reserves the right, in its sole discretion, to change its Terms and Conditions at any time, for any reason, without notice.**

**2. WhisperKOOL Product Installation and Limited Warranty**

- A. Purchaser of the product must arrange for the product to be installed by a certified HVAC/R technician in accordance with procedures set forth by WhisperKOOL and described in the WhisperKOOL Owner's Manual.
- B. The HVAC/R technician installing the product must complete the designated portion of the Split Startup Checklist and provide licensing or certification identification number information to assist in the warranty registration process.
- C. Purchaser must return the completed Split Startup Checklist to WhisperKOOL within thirty (30) days of installation of Product. The Split Startup Checklist must be approved by WhisperKOOL to activate the Limited Warranty. If the Split Startup Checklist is approved, Purchaser will be sent activation approval documents and will start receiving the benefits of the Limited Warranty throughout the warranty period. If the Split Startup Checklist is incomplete, Purchaser will be informed they have five days to complete the Split Startup Checklist and re-submit to WhisperKOOL. The Split Startup Checklist will be reviewed again, and if denied, Purchaser will be informed that they have 10 business days for corrective action. Failure to register the Product may result in loss of warranty.
- D. Purchaser is responsible for the full costs of installation and any additional parts required for the proper and complete installation of the product.
- E. For Split Systems returned to WhisperKOOL in accordance with the terms and conditions of the Limited Warranty, WhisperKOOL warrants against defects in material and workmanship as follows:
  1. **LABOR** — For a period of two (2) years commencing on the date of purchase, WhisperKOOL will, at its option and discretion, reimburse up to \$250 to the End User for cost incurred for servicing, repairing, removing or installing warranty parts. Invoice for service must be forwarded to WhisperKOOL for assessment and processing. The Split System warranty is invalid if there is attempted repair by anyone other than an HVAC/R technician approved by WhisperKOOL to service the Product.
  2. **PARTS** — For a period of two (2) years commencing on the date of purchase, WhisperKOOL will supply, at no charge, new or rebuilt replacement parts in exchange for defective parts. Replacement parts are warranted only for the remainder of the original warranty period.
  3. **FREIGHT** — For a period of two (2) years commencing on the date of purchase, if after WhisperKOOL approved evaluation the original Product failure is determined to be the cause of a manufacturers defect, and not the cause of an installation error or other cause, WhisperKOOL will cover at its option, freight for the replacement parts or Product.

**The following part or cause of failure is not the responsibility of WhisperKOOL:**

- Improper voltage supply
- Line set with screw connectors (high end and low end)
- Leaks found at the braze points when performing pressure check
- Unit that has been charged incorrectly

- Incorrect tubing diameter used on line set
- A unit that has been wired incorrectly
- Valve stem on condenser side
- Improper installation of P-Trap
- Lack of P-Trap (if required)
- Condensers that are installed outdoors or in elements that would affect operation without proper cover or housing. (Housing is available from Manufacturer).

**Product Warranty Limitations and Exclusions.**

1. This limited warranty does not cover cosmetic damage caused during installation, damage due to acts of God, commercial use, accident, misuse, abuse, negligence, or modification to any part of the Product. Delivery and installation of the Product, any additional parts required, as well as removal of the Product if warranty work is required, are all at the sole cost, risk and obligation of the End User.
2. This limited warranty does not cover damage due to improper installation or operation or lack of proper maintenance of the Product, connection of the Product to improper voltage supply, or attempted repair of the Product by anyone other than a technician approved by WhisperKOOL to service the Product.
3. This limited warranty does not cover any Product sold "AS IS" or "WITH ALL FAULTS."
4. Product that has been replaced during warranty period does not extend the warranty period past the original date of purchase.
5. This limited warranty is valid only in the continental United States. Sales elsewhere are excluded from this warranty.
6. Proof of purchase of the Product in the form of a bill of sale, receipted invoice or serial number, which is evidence that the Product is within the Limited Warranty Period, must be presented by the End User to WhisperKOOL in order to obtain limited warranty service.
7. This limited warranty is void if the factory applied serial number has been altered or removed from the Product.
8. This limited warranty is voided if installed in an enclosure of insufficient design that does not follow the Product installation requirements stated herein and in the owner's manual.
9. Removing the rivets from the Product's unit housing without prior authorization from WhisperKOOL voids this limited warranty.
10. The End User must first contact WhisperKOOL Customer Service prior to attempting service on any Product still under the limited warranty; else the limited warranty is voided.
11. This limited warranty does not cover Product being concealed by, but not limited to, vegetation, fabric, shelving, mud, snow, or dirt. Product must not be painted or limited warranty will be void.
12. This limited warranty does not cover exposure to corroding environments such as, but not limited to, petroleum and gasoline products, cleaning solvents, caustic pool chemicals, and marine air.
13. This limited warranty does not cover any cause not relating to Product defect.
14. THE REPAIR OR REPLACEMENT OF THE PRODUCT AS PROVIDED UNDER THIS LIMITED WARRANTY IS THE EXCLUSIVE REMEDY OF YOU, THE END USER, AS WELL AS ANYONE ELSE IN THE CHAIN OF TITLE OF THE PRODUCT, DOES NOT START A NEW LIMITED WARRANTY TIME PERIOD, AND IS IN LIEU OF ALL OTHER WARRANTIES (EXPRESS OR IMPLIED) WITH REGARD TO THE PRODUCT. IN NO EVENT SHALL WHISPERKOOL BE LIABLE FOR INCIDENTAL, CONSEQUENTIAL, SPECIAL OR CONTINGENT DAMAGES FOR BREACH OF ANY EXPRESS OR IMPLIED WARRANTY ON THIS PRODUCT. THE IMPLIED WARRANTIES OF MERCHANTABILITY
15. AND FITNESS FOR A PARTICULAR PURPOSE ARE HEREBY EXPRESSLY DISCLAIMED. Some states do not allow the exclusion or limitation of incidental or consequential damages, or allow limitations on how long an implied warranty lasts, so the above limitations or exclusions may not apply to you. This limited warranty gives you specific legal rights, and you may have other rights, which vary from state to state.
16. Failure of the End User to comply with all of the Product Installation Requirements, Maintenance Requirements and End User Requirements may, at WhisperKOOL's sole discretion, void this limited warranty.
17. No one has any authority to add to or vary the limited warranty on this Product.



### 3. Maintenance Requirements

The End User is responsible for checking the coils on the condenser unit and vacuuming them every three months to maintain them free of debris. It is the End User's responsibility to clean off any accumulated dust, lint, or other debris from the front and rear intake grills; failure to do this on a regular basis will restrict the airflow and may affect the Product's ability to function properly. Periodically cleaning the Product's vents will help assure maximum cooling efficiency. The drain tube must also be checked and kept clean and free of debris and mold to maintain proper performance.

Mold is a natural living organism in the environment. It exists in the air in the form of microscopic spores that move in and out of buildings through doors, windows, vents, HVAC systems and anywhere else that air enters. Once it is discovered, mold must be addressed quickly and appropriately. Delayed or improper treatment of mold issues can result in costly and reoccurring repairs. If the End User suspects a mold problem, it is always best to hire a qualified and experienced mold remediation specialist.

### 4. Additional End User Costs And Responsibilities

#### Terms and conditions for replacing the Product that is being evaluated for limited warranty.

1. After evaluation by a certified HVAC/R technician and the Product is found to be irreparable in the field, contact WhisperKOOL Customer Service to arrange for replacement under the warranty guidelines. When a claim for warranty is submitted for a condenser skid, the End User must purchase a new condenser skid from WhisperKOOL at retail price. Upon installation of the new condenser skid by a certified HVAC/R Technician, the HVAC/R Technician must complete the Installation Checklist and End User must submit the Installation Checklist to WhisperKOOL Customer Service for approval. The original condenser skid must be returned within 21 days to WhisperKOOL for failure analysis. If the Installation Checklist is approved and the failure is evaluated as defective and not installation error or other reason, the End User will be refunded for the cost of the replacement skid.
2. If the Product failure is evaluated and it is determined that it is an installation error or other reason, all costs, including shipping will be the responsibility of the End User.

The following items are not covered under any warranty and are the sole responsibility of the End User:

- A. End Users should satisfy themselves that the Product they are purchasing is suitable for their particular needs and requirements, and thus no responsibility will be placed with WhisperKOOL for the End User's decisions in this regard.
- B. End Users must assure that the product is installed by a certified HVAC/R technician. Failure to do so will result in Voiding the Limited Warranty.
- C. It is the End User's responsibility to secure safe haven/storage for ANY AND ALL items that are being kept and stored in the End User's wine cellar, including any Product. WhisperKOOL takes no responsibility for the safety and preservation of the aforementioned items in the event that the environment becomes unsuitable to maintain a proper storage environment.
- D. End User is responsible for initial installation costs, including, but not limited to, labor costs and the cost of any additional parts necessary to complete the installation.
- E. End User is responsible for all costs incurred for the installation and/or removal of the Product, or any part thereof, unless such cost has been agreed by WhisperKOOL to be a warranty repair prior to the work being performed.

### 5. Sales and Use Tax

WhisperKOOL only collects California sales tax for orders shipped within the State of California; WhisperKOOL does not collect sales tax for orders shipped to other states. However, the Purchaser and the End User may be liable to the taxing authority in their state for sales tax and/or use tax on the Product. The Purchaser and the End User should each check with their state's taxing authority for sales and use tax regulations.

### 6. Customer Service and Troubleshooting

WhisperKOOL's customer service department is available to answer any questions or inquiries for End Users regarding a WhisperKOOL Product, as well as to assist in performing basic troubleshooting, Monday through Friday, from 6:00 a.m. to 4:00 p.m. PST, at telephone number support@WhisperKOOL.com. WhisperKOOL reserves the right to have a certified, WhisperKOOL-approved, HVAC/R technician go on site and inspect the product if the initial trouble shooting warrants further investigation.

WhisperKOOL Corporation is located at 1738 East Alpine Avenue, Stockton, California 95205.

## 7. Request for Product Evaluation and Repair Under Warranty

**SPLIT SYSTEM FIELD SERVICE WARRANTY POLICY:** This Policy is to clarify what falls under Warranty Service and what becomes the responsibility of the Owner. WhisperKOOL (“manufacturer”) strives to provide our customers with a superior Product and we back our Product with a Two Year Limited Warranty. Please review the WhisperKOOL Product Terms and Conditions including Product Limited Warranty and Product Installation Requirements to ensure you have a complete understanding of our Policy and coverage of your Split System.

**ARBITRATION:** Any disputes arising out of or in connection with the installation and warranty of the Split System shall be referred to and finally resolved by a WhisperKOOL approved Independent Certified HVAC/R Technician. The evaluation of the Technician on all issues or matters of identifying the responsible party (WhisperKOOL or Installing Technician) shall be determined in a written report. This report will be made available to all concerned parties. If discovered under warranty, WhisperKOOL will assume the financial responsibility under their warranty guidelines. If the report finds the Owner’s Installer as the responsible party, WhisperKOOL will provide all documentation to the customer to substantiate the findings. This will include the Invoice from the Independent Certified HVAC/R Technician and the written report of the findings. The Owner will become responsible for payment directly to WhisperKOOL for all charges incurred for repairs (labor, parts and shipping costs) on the Split System.

## 8. Miscellaneous Terms and Conditions

- A. Return Policy. All return inquiries must be made within thirty (30) calendar days of the original purchase of a Product and are subject to a twenty five percent (25%) restocking fee. Shipping costs are not refundable and the Purchaser is responsible for all return shipping costs (including customs fees and duties, if applicable).
- B. Security Interest. WhisperKOOL retains a security interest in each Product until payment in full.
- C. Construction and Severability. Every provision of these Terms and Conditions shall be construed, to the extent possible, so as to be valid and enforceable. If any provision of these Terms and Conditions is held by a court of competent jurisdiction to be invalid, illegal or otherwise unenforceable, such provision will, to the extent so held, be deemed severed from the contract of sale between Purchaser and WhisperKOOL, and all of the other non-severed provisions will remain in full force and effect.
- D. Governing Law/Choice of Forum. The laws of the State of California (without regard for conflicts of law) shall govern the construction and enforcement of the these Terms and Conditions of Sale (Sections 1 through 9 inclusive, including Product Limited Warranty And Product Installation Requirements), and further these Terms and Conditions of Sale shall be interpreted as through drafted jointly by WhisperKOOL and Purchaser. Any dispute will be resolved by the courts in and for the County of San Joaquin, State of California, and all parties, WhisperKOOL, Purchaser and End User, hereby irrevocably submit to the personal jurisdiction of such courts for that purpose. No waiver by WhisperKOOL of any breach or default of the contract of sale (including these Terms and Conditions of Sale) concerning a Product will be deemed to be a waiver of any preceding or subsequent breach or default.
- E. Correction of Errors and Inaccuracies. These Terms and Conditions may contain typographical errors or other errors or inaccuracies. WhisperKOOL reserves the right to correct any errors, inaccuracies or omissions, and to change or update these Terms and Conditions, at any time without prior notice.

## 9. Questions, Additional Information And Technical Assistance

- A. Questions. If you have any questions regarding these Terms and Conditions or wish to obtain additional information, contact us at [support@WhisperKOOL.com](mailto:support@WhisperKOOL.com) or please send a letter via U.S. Mail to:

Customer Service  
WhisperKOOL Corporation  
1738 E Alpine Ave  
Stockton, CA 95205

E-mail: [support@whisperkool.com](mailto:support@whisperkool.com)  
Web: [www.whisperkool.com](http://www.whisperkool.com)

- B. Technical Assistance. WhisperKOOL Customer Service is available Monday through Friday from 6:00 a.m. to 4:00 p.m. PST. The Customer Service representative will be able to assist you with your questions and warranty information more effectively if you provide them with the following:
  - 1. The model and serial number of your WhisperKOOL UNIT.
  - 2. The location of the system and installation details, such as ventilation, construction of your wine cellar, and room size.

**Model** \_\_\_\_\_ **Serial Number** \_\_\_\_\_

**Installed by** \_\_\_\_\_ **Date** \_\_\_\_\_

*Whisper***KOOL**<sup>™</sup>

WhisperKOOL  
1738 E. Alpine Ave  
Stockton, CA 95205  
[www.whisperkool.com](http://www.whisperkool.com)

***PLATINUM SPLIT TWIN***  
**VERSION 5**  
**OWNER'S MANUAL**

*24V Thermostat Conversion Kit Option*

*Whisper***KOOL**<sup>TM</sup>  
*The Coolest Thing In Wine Storage*

**Conforms to ANSI/UL Std 427**

**Certified to CAN/CSA Std C22.2 No. 120**

***We manufacture, test and certify 100% of our wine cooling units in the USA. By sourcing the best components and closely controlling our manufacturing processes, we can assure the highest-quality, lowest defect manufacturing rates in the industry.***

Copyright © 2022. WhisperKOOL. All rights reserved.

WhisperKOOL copyrights this manual, the product design, and the design concepts, with all rights reserved. Your rights with regard to the hardware and manual are subject to the restrictions and limitations imposed by the copyright laws of the USA. Under copyright laws, this manual may not be copied, reproduced, translated, transmitted, or reduced to any printed or electronic medium or to any machine-readable form, for any purpose, in whole or in part, without the written consent of WhisperKOOL.

Every effort has been made to ensure that the information in this manual is accurate. WhisperKOOL is not responsible for printing or clerical errors.

WhisperKOOL reserves the right to make corrections or improvements to the information provided and to the related hardware at any time, without notice.

Vinothèque and WhisperKOOL are registered trademarks, and ECE is a trademark of WhisperKOOL. All rights reserved.

Mention of third-party products is for informational purposes only and constitutes neither an endorsement nor a recommendation. WhisperKOOL assumes no liability with regard to the performance or use of these products.

# TABLE OF CONTENTS

<b>Introduction</b> .....	<b>2</b>
<b>Before You Start</b> .....	<b>3</b>
<b>Receiving &amp; Inspecting the System</b> .....	<b>4</b>
<b>Quick Reference Guide</b>	
Wall-Mounted Evaporator Unit .....	<b>5</b>
Fully Ducted Evaporator Unit .....	<b>6</b>
Wall-Mounted Twin Specifications .....	<b>7</b>
Fully Ducted Twin Specifications .....	<b>8</b>
Condensing Unit Quick Reference Guide .....	<b>9</b>
<b>Preparing the Wine Cellar</b> .....	<b>10</b>
<b>System Operation</b> .....	<b>13</b>
<b>WhisperKOOL Troubleshooting Guide</b> .....	<b>16</b>
<b>Maintenance Schedule</b> .....	<b>19</b>
<b>Technical Assistance &amp; Accessories</b> .....	<b>20</b>
<b>Installation Terms and Conditions</b> .....	<b>21</b>

## INTRODUCTION

### Customer Service

Thank you for purchasing a WhisperKOOL cooling system. We strive to provide the highest-quality products and the best possible customer service. If you have any questions about your system, please visit [WhisperKOOL.com](http://WhisperKOOL.com).

### Using the Manual

This manual is intended to assist in the proper maintenance of the cooling system. In order to ensure the longevity of your cooling unit, the equipment should be installed as outlined in the technician's manual. It is also vital to establish a proper care and maintenance schedule. Please read and review this manual carefully and keep it for future reference.

### What is the WhisperKOOL Cooling System?

The WhisperKOOL cooling system is a specialized refrigeration system designed for one purpose only: to maintain the optimal temperature and humidity levels conducive to the proper storage and aging of fine wines. This system produces minimal in-cellar noise and has the most lenient exhaust requirements. An exterior housing is required for outdoor condensing unit installations.

### How Does the Cooling System Work?

Similar to the air conditioning systems used for homes, the evaporator unit and condensing units are installed in separate locations and are connected by a refrigerant line set. The evaporator portion is commonly installed in the wine cellar, with the condensing unit is located either outside or in a remote indoor location that is ventilated. An exterior housing is required for outdoor condensing unit installations.

### Temperature Setting

The system is designed to maintain a cellar temperature of 55°F as long as the ambient temperature does not exceed 110°F.

## WARRANTY REGISTRATION

In order to activate the warranty of your system, the verification and operational documentation must be completed by the certified refrigeration technician installing your system and submitted via mail, fax, or e-mail.

Mail to:  
WhisperKOOL  
ATTN: Warranty Registration  
1738 E. Alpine Avenue  
Stockton, CA 95205-2505  
USA

Fax to:  
209-466-4606

Scan and email to:  
[warranty@whisperkool.com](mailto:warranty@whisperkool.com)



## BEFORE YOU START

1. **Inspect all components prior to installation.** If damage is found, please contact your distributor or WhisperKOOL Customer Service at support@WhisperKOOL.com.
2. Each evaporator unit **requires a dedicated 115V, 15-amp circuit.** The condensing unit **requires a dedicated 230V single-phase 15-amp circuit.** Use a surge protector with the unit. **Do not use a GFI** (ground fault interrupter) line.
3. You are **REQUIRED** to **install a drain line** to remove condensation from each evaporator unit.
4. ***The warranty is not active until a warranty checklist has been received, reviewed, and approved.***
5. The system is intended **for use in properly designed and constructed wine cellars.** Hire a professional wine storage consultant with a valid contractor's license to build your wine cellar.
6. WhisperKOOL requires that all split systems be installed by a certified HVAC-R technician only. NATE or equivalent is recommended.
7. ***It is vital that the units be set apart and oriented so that the return air from one unit does not recirculate into the supply air of the other unit.***

If you encounter a problem with your WhisperKOOL system, please refer to the Troubleshooting Guide. If you have any further questions or concerns, or need assistance, please contact WhisperKOOL's Customer Service at support@WhisperKOOL.com. Please be sure all testing has been completed prior to contacting Customer Service. Please have your results ready for your representative.

## RECEIVING & INSPECTING THE SYSTEM

- Use caution when lifting and check package for damage.
- Lift only at the designated hand-hold locations on the shipping container, or fully support the unit from underneath. A shipment may include one or more boxes containing accessories.
- Before opening the container, inspect the packaging for any obvious signs of damage or mishandling.
- Write any discrepancy or visual damage on the bill of lading before signing.
- Allow the condensing unit to sit for 24 hours prior to start-up. The condensing unit can be placed in the installation location, piped, and evacuated during this time.

**NOTE:** WhisperKOOL units are manufactured in the USA and tested prior to shipment.

- Review the packing slip to verify contents.
- Check the model number to ensure it is correct.
- Check that all factory options ordered are listed.

**If any items listed on the packing slip do not match your order information, contact WhisperKOOL Customer Service immediately.**

Check all shipped boxes for the following contents:

### Master Evaporator Box

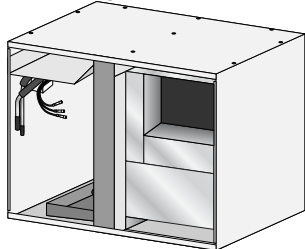

- (1) Master Platinum Split Twin evaporator unit
- (1) Wall-mounted evaporator installation template

#### Documentation bag (master):

- Platinum Split Twin owner's manual
- Platinum Split Twin technician's manual
- R-134a split system warranty checklist

#### Evaporator installation hardware bag (master)

- (2) 1/2" x 1/2" 90° nylon barbed fitting
- (1) 1/2" barbed tee
- (1) Double-D strain relief
- (4) 3/4" adhesive cable tie mounts
- (2) Small cable ties
- (4) #8 x 1 3/4" hex-head screws

### Slave Evaporator Box

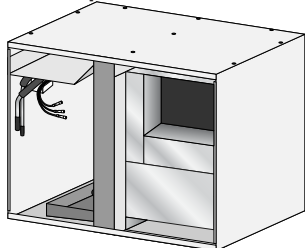

- (1) Slave Platinum Split Twin evaporator unit
- (1) Wall-mounted evaporator installation template
- (1) Evaporator installation hardware bag

- (2) 1/2" x 1/2" 90° nylon barbed fitting
- (1) 1/2" barbed tee
- (1) Double-D strain relief
- (4) 3/4" adhesive cable tie mounts
- (2) Small cable ties
- (4) #8 x 1 3/4" hex-head screws

### Condensing Unit Box

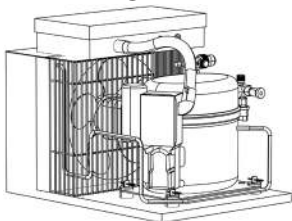

- (1) Condensing unit
- (1) Condensing unit accessory kit:
  - (1) 1/4" filter drier
  - (1) 1/4" sight glass

### Ducted Master Accessory Kit Box

(1) Duct plenum

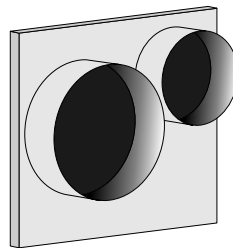

### Wall-Mounted Master Accessory Kit Box

(1) Filter grille

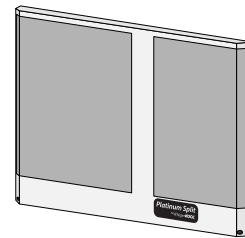

OR

### Ducted Slave Accessory Kit Box

(1) Duct plenum

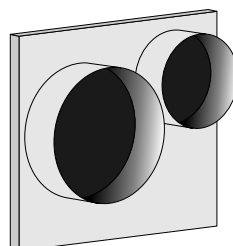

### Wall-Mounted Slave Accessory Kit Box

(1) Filter grille

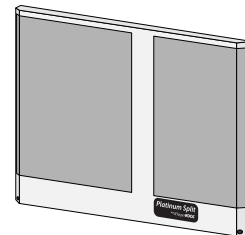

OR

Please leave the unit in its original box until you are ready for installation. This will allow you to move the product safely without damaging it. When you are ready to remove the product from the box, refer to the installation instructions.

**TIP:** Save your box and all packaging materials. They provide the only safe means of transporting/shipping the unit.

# QUICK REFERENCE GUIDE

## Front / Side View

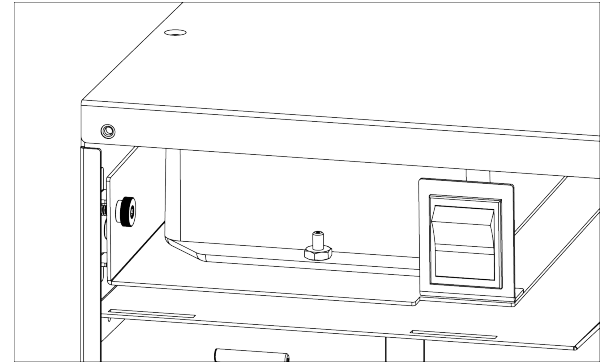
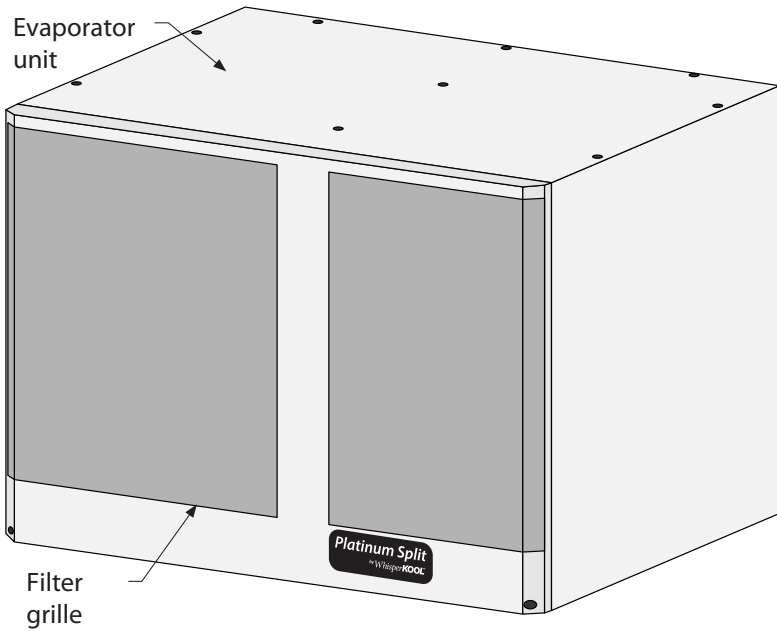

### Fan Speed Switch

The cooling system comes equipped with a variable fan speed switch. Increasing the fan speed increases the volume of cool air blown from the system. It is set by the factory to MED. To access the fan speed switch it is necessary to remove the front grille.

## Wall-Mounted — Rear / Side View

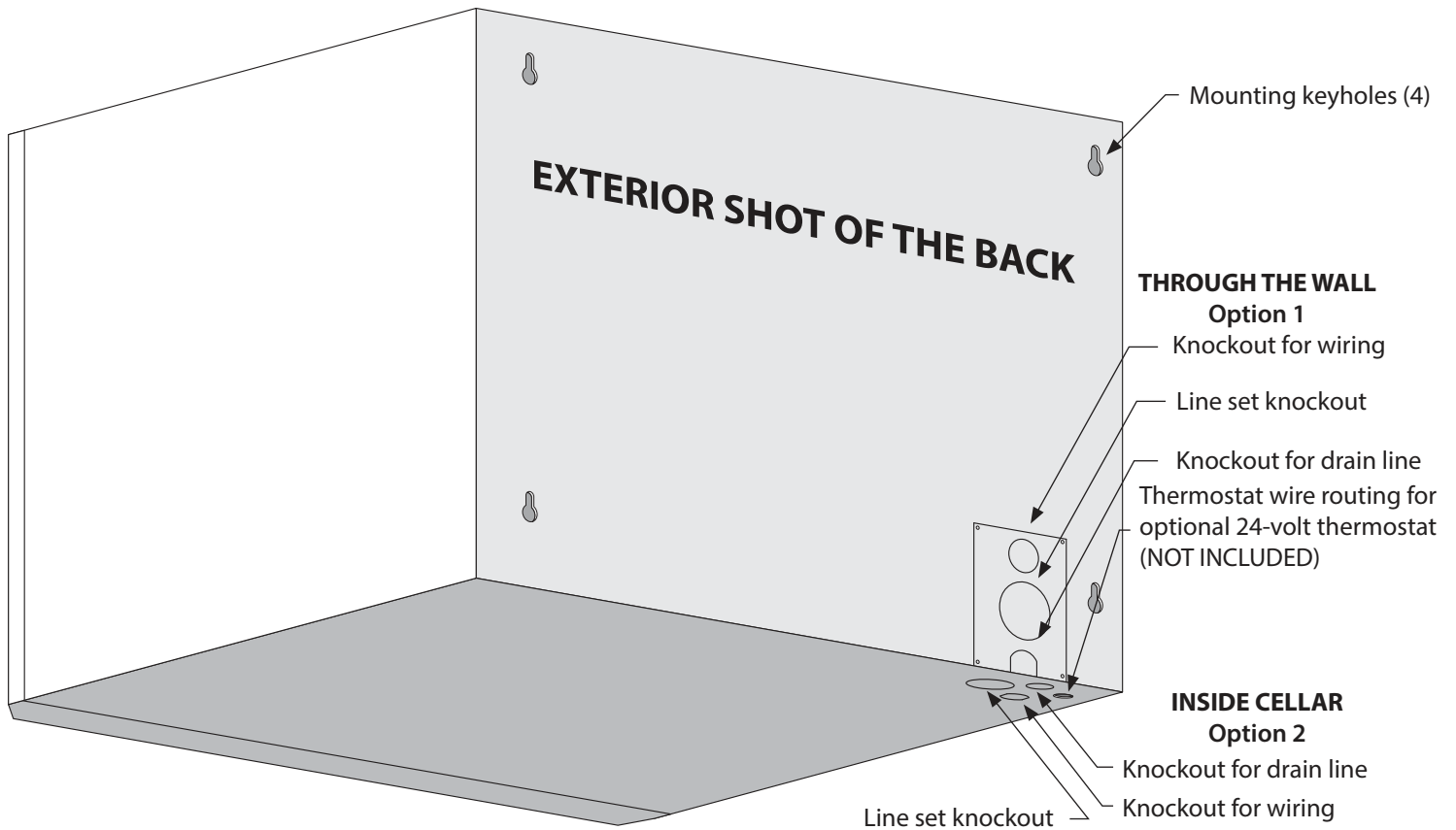

Fully Ducted — Front / Side View

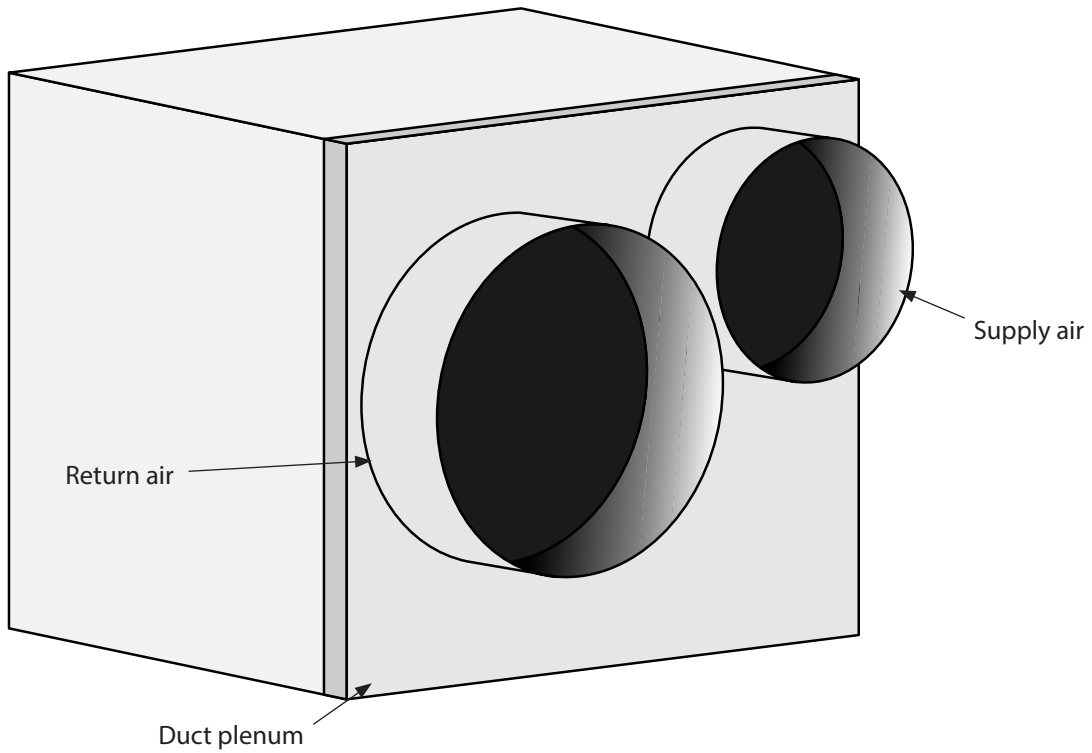

Fully Ducted — Rear / Side View

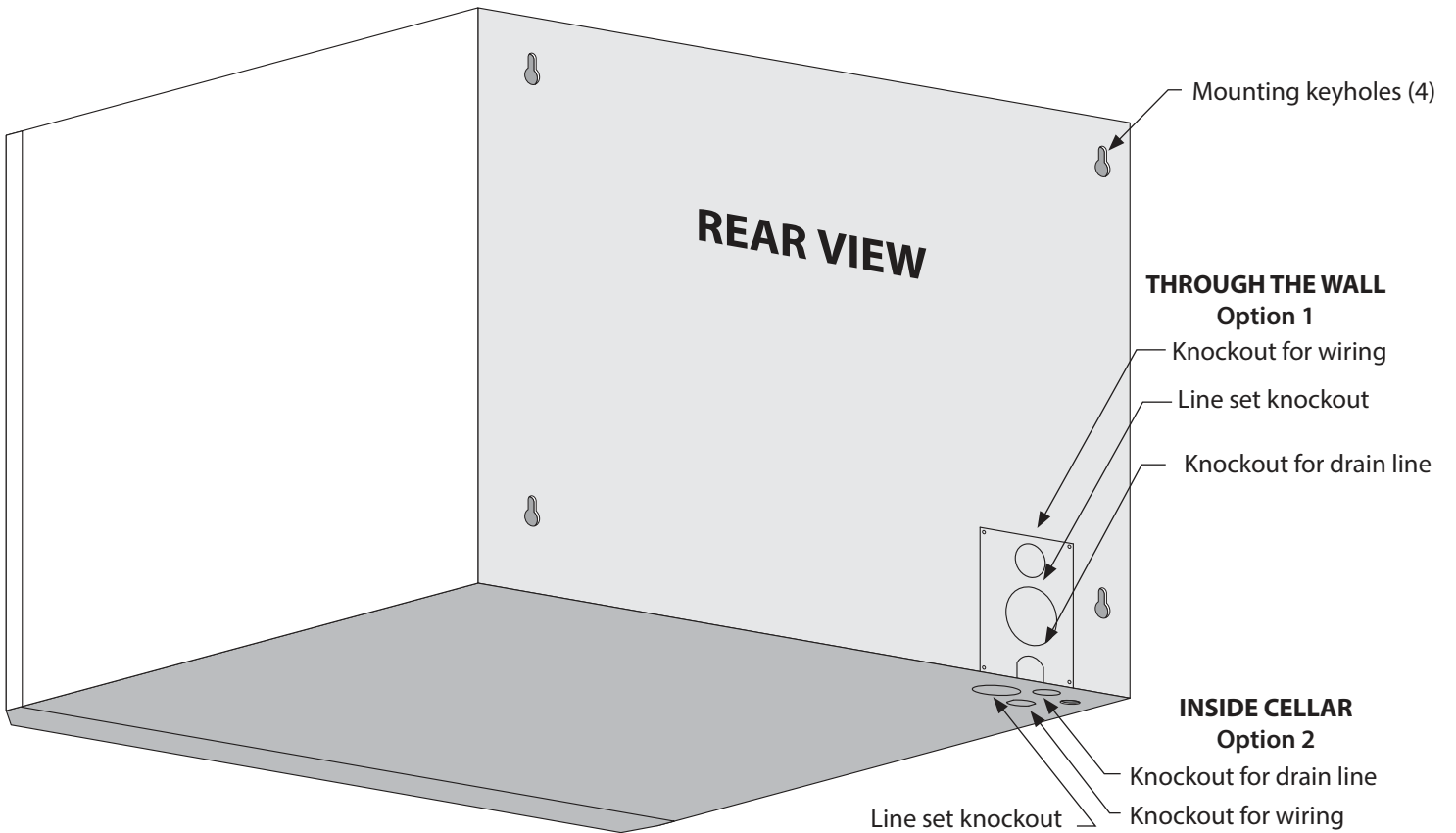

# WALL-MOUNTED TWIN SPECIFICATIONS

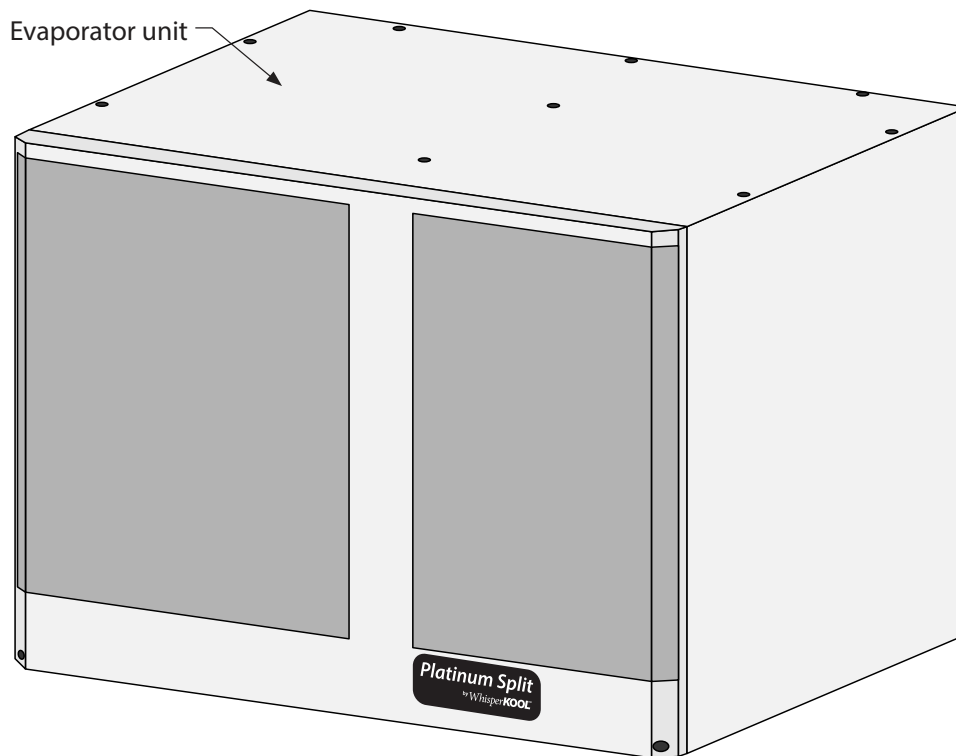

Model	9000 Master Evaporator (Fan Coil Unit)	9000 Slave Evaporator (Fan Coil Unit)
Cellar Size	Approx. 3000 cu. ft., provided cellar is fully insulated and sealed with proper vapor barrier*	
BTU/h w/85°F air entering condenser coil	Low: 6843/7845 • Medium: 7368/7959 • High: 7779/8054	
Dimensions	16.1"L x 20.5"W x 15.5"H	16.1"L x 20.5"W x 15.5"H
Refrigerant	R-134a	R-134a
Voltage Rating	115V (15-amp dedicated circuit required)	115V (15-amp dedicated circuit required)
Weight (lbs)	57	57
Amps	Evaporator: 1 running amp (per unit) Compressor: LRA 50, RLA 9.3	Evaporator: 1 running amp (per unit) Compressor: LRA 50, RLA 9.3
Line Set	Liquid line 3/8"; suction line 3/4" (less than 50 ft.), 7/8" (greater than 50 ft.)	
Drain Line	1/2" ID clear plastic tubing (not provided)	
Installation	Evaporator units are installed in the cellar.	
Thermostat	Advanced digital display (50-ft. cable), liquid-temperature-measuring bottle probe (50-ft. cable)	
Temp. Delta	Can maintain a 55°F temperature differential with up to 110°F condenser air intake temperature	
Warranty	Two-year limited warranty (parts and labor)	

\*Each cellar is unique and has specific cooling requirements. Heat load calculations should always be performed prior to selecting a cooling unit.

# FULLY DUCTED TWIN SPECIFICATIONS

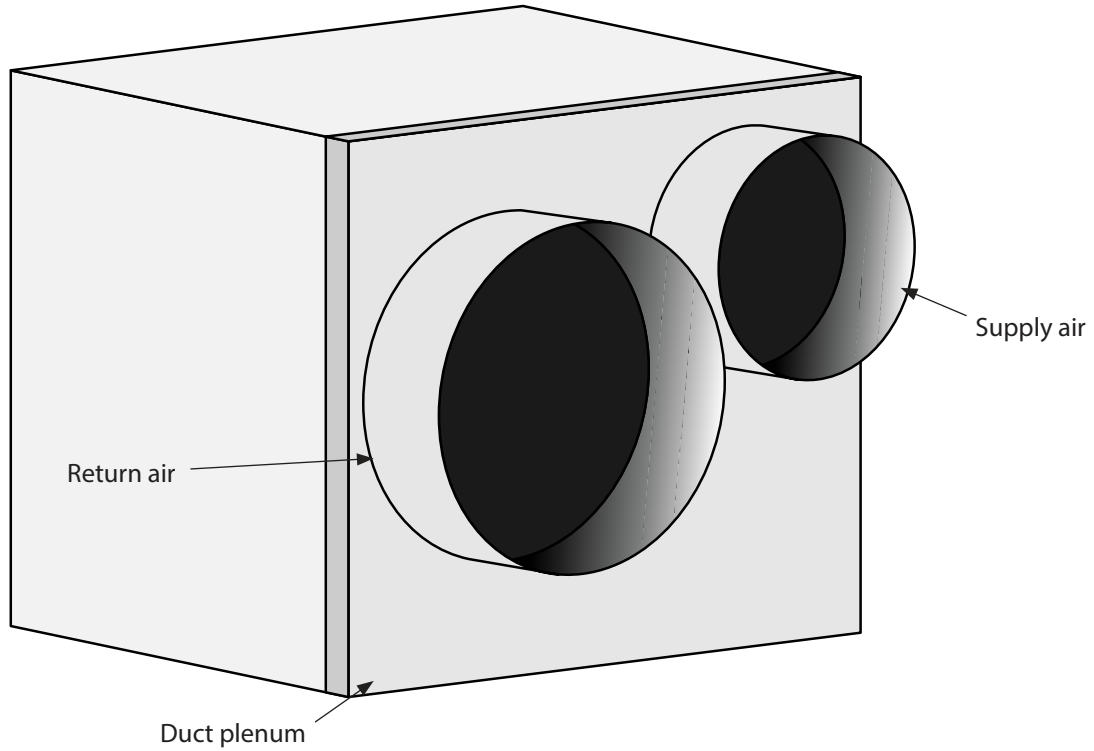

Model	9000 Master Evaporator (Fan Coil Unit)	9000 Slave Evaporator (Fan Coil Unit)
Cellar Size (cu. ft.)	Approx. 3000 cu. ft., provided cellar is fully insulated and sealed with proper vapor barrier*	
BTU/h w/85°F air entering condenser coil	Low: 6450/7366 • Medium: 7083/7657 • High: 7281/7879	
Dimensions	22.1"L x 22.5"W x 15.5"H	22.1"L x 22.5"W x 15.5"H
Refrigerant	R-134a	R-134a
Voltage Rating	115V (15-amp dedicated circuit required)	115V (15-amp dedicated circuit required)
Weight (lbs)	57	57
Amps	Evaporator: 1 running amp (per unit) Compressor: LRA 50, RLA 9.3	Evaporator: 1 running amp (per unit) Compressor: LRA 50, RLA 9.3
Line Set	Liquid line 3/8"; suction line 3/4" (less than 50 ft.), 7/8" (greater than 50 ft.)	
Duct Size	8" supply, 10" return (x2)	
Drain Line	1/2" ID clear plastic tubing (not included)	
Installation	Evaporator units can be installed up to 25 ducted feet away.	
Thermostat	Advanced digital display (connected to master unit) with 50-ft. cable; liquid-temperature-measuring bottle probe (also with 50-ft. cable)	
Temp. Delta	Can maintain a 55°F cellar temperature with up to 110°F condenser air intake temperature	
Warranty	Two-year limited warranty (parts and labor)	

\*Each cellar is unique and has specific cooling requirements. Heat load calculations should always be performed prior to selecting a cooling unit.

**CONDENSING UNIT SPECIFICATIONS**

Model	9000 Condenser (Air-Cooled Condensing Unit)
Dimensions	24"L x 18.98"W x 16.16"H
Refrigerant	R-134a
HP	Ducted system: 3.1, non-ducted system: 3.34
Voltage Rating	230V (15-amp dedicated circuit required)
Weight (lbs)	75
Installation	Condensing unit can be installed up to 100 line feet from master evaporator unit.
Warranty	Two-year limited warranty (parts and labor)

## PREPARING THE WINE CELLAR

The performance and life of your system is contingent upon the steps you take in preparing the wine cellar. Improperly preparing your enclosure or incorrectly installing your unit may cause unit failure, leaking of condensation, and other negative side effects.

**It is highly recommended that you obtain the assistance of a wine storage professional.**

Wine storage professionals work with licensed contractors, refrigeration technicians, and racking companies to build well-insulated, beautiful, and protective wine cellars. WhisperKOOL has put together some useful tips to assist in the installation process. Our recommendations are meant to act as a guide in the process of building a proper enclosure. Your intended location may have specific needs which we do not address.

### Wall & Ceiling Framing

Build wine cellar walls using standard 2x4 or 2x6 boards and ceiling joists without violating local or state codes in your area. As a general rule, the thicker the walls and the higher the insulation value, the more consistent your cellar temperature will be.

### Insulation

Insulation is **REQUIRED** in order to properly use WhisperKOOL products. It is vital that all walls and ceilings be insulated to keep the cellar temperature as consistent as possible during the summer and winter months. Standard fiberglass or rigid foam insulation is normally used in cellar construction; in some cases, “blown-in” insulation is used. The R-value, or quality of insulation, is determined by the rate at which heat passes through the insulation. The higher the R-value, the more resistant the insulation is to conducting heat, and the more consistent your wine cellar’s temperature will be. Using higher R-values in insulation will lower your operating costs and WhisperKOOL unit run time. (R-13 is the recommended minimum; R-19 is preferred for interior cellar walls, and R-30 for ceilings and exterior walls.)

### Vapor Barrier

Water vapor creates its own pressure, separate from the ambient air pressure, and will intrude into colder/drier areas. A vapor barrier is **REQUIRED** in order to prevent the intrusion of water vapor and maintain the correct cellar temperature and humidity. It is recommended that 6-millimeter plastic sheeting be applied to the warm side of the cellar walls. The vapor barrier must also be applied to the outside walls and ceiling. If it is impossible to reach the outside, then the plastic must be applied from within the cellar. The most common method is to wrap the entire interior, leaving the plastic loose in the stud cavity so the insulation can be placed between each stud. All of the walls and ceiling must be wrapped in plastic for a complete vapor barrier.

In areas of high humidity, such as Southern and Gulf States, the vapor barrier will prevent infiltration of warm moist air. The moist air can cause mold to form, and standing water in drain pans promote microbial and fungal growth that cause unpleasant odors and indoor air quality problems. If mold is found, remove it immediately and sanitize that portion of the unit.

**Note:** High humidity significantly increases the heat load on the cooling system.

Any break in the vapor barriers (cut, nail hole, over-lapping, etc.) will cause a moisture leak and must be sealed. The electric conduit is a “duct” for vapor to travel in. The conduit should be caulked and sealed on the warm air end.



## Mounting the Evaporator Units

The evaporator units must be mounted within 18" of the top of the room in order to achieve sufficient cooling. As the room cools down, the warm air will rise to the ceiling. Mounting the units high in the room will create a consistently cool environment by capturing the warm air and replacing it with cool air. Mounting the units low in the room will result in a temperature variation in the room due to the units' inability to draw warm air from the ceiling of the cellar to the units themselves, and cold air settling to the floor.

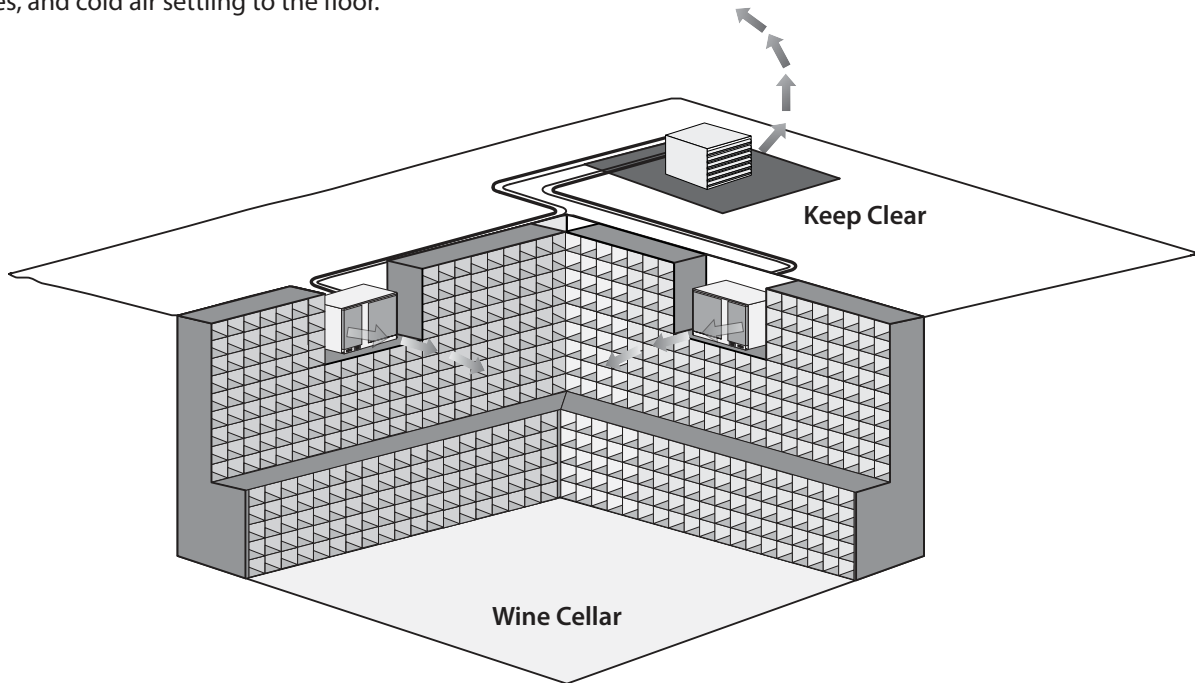

### Unobstructed Airflow

Unobstructed airflow to and from the system is critical for the system's overall performance and lifespan. Make sure there is a minimum of three (3) feet of horizontal clearance in every direction around the units (five feet is ideal). The air blown by the fans needs to circulate and either dissipate or absorb heat from the space. The system will operate more efficiently with a greater amount of air to exchange.

**NOTE:** Avoid attempting to camouflage the units. This will restrict airflow and thus the system's ability to work efficiently.

**NOTE:** For ducted systems, every 90° bend in the ducting causes the system to lose 13 CFM of airflow.

### Door and Door Seal

An exterior grade (1 $\frac{3}{4}$ " ) door must be installed as a cellar door. It is essential that weather stripping is attached to all 4 sides of the doorjamb. A bottom "sweep" or threshold is also required. The door must have a very good vapor seal to prevent warmer moist air from leaking into the cellar. One of the most common problems with cooling systems running continually is due to the door not sealing properly. **In cases where glass doors are used and the room size is close to the recommended system size, the next larger size WhisperKOOL system should be used.** This will compensate for the insulation loss due to the lower insulating rating of glass.



## Ventilation

The necessity of dissipating heat away from the condensing unit is critical to the unit's performance and cannot be overstated. As the system operates and cools, a greater amount of heat is generated on the condensing side of the system. Adequate ventilation is required in order to dissipate heat away from the condensing unit. If ventilation is inadequate, the exhaust will heat up the area or room and adversely affect the systems ability to cool. In some cases, it may be advisable to install a vent fan to dissipate heat within the exhaust area on the condensing side of the system. However, you must have a fresh air inlet as well.

**NOTE:** If you are unsure about having adequate ventilation in your install location, please contact us to assess your specific installation at [support@whisperkool.com](mailto:support@whisperkool.com) or 1-800-343-9463.

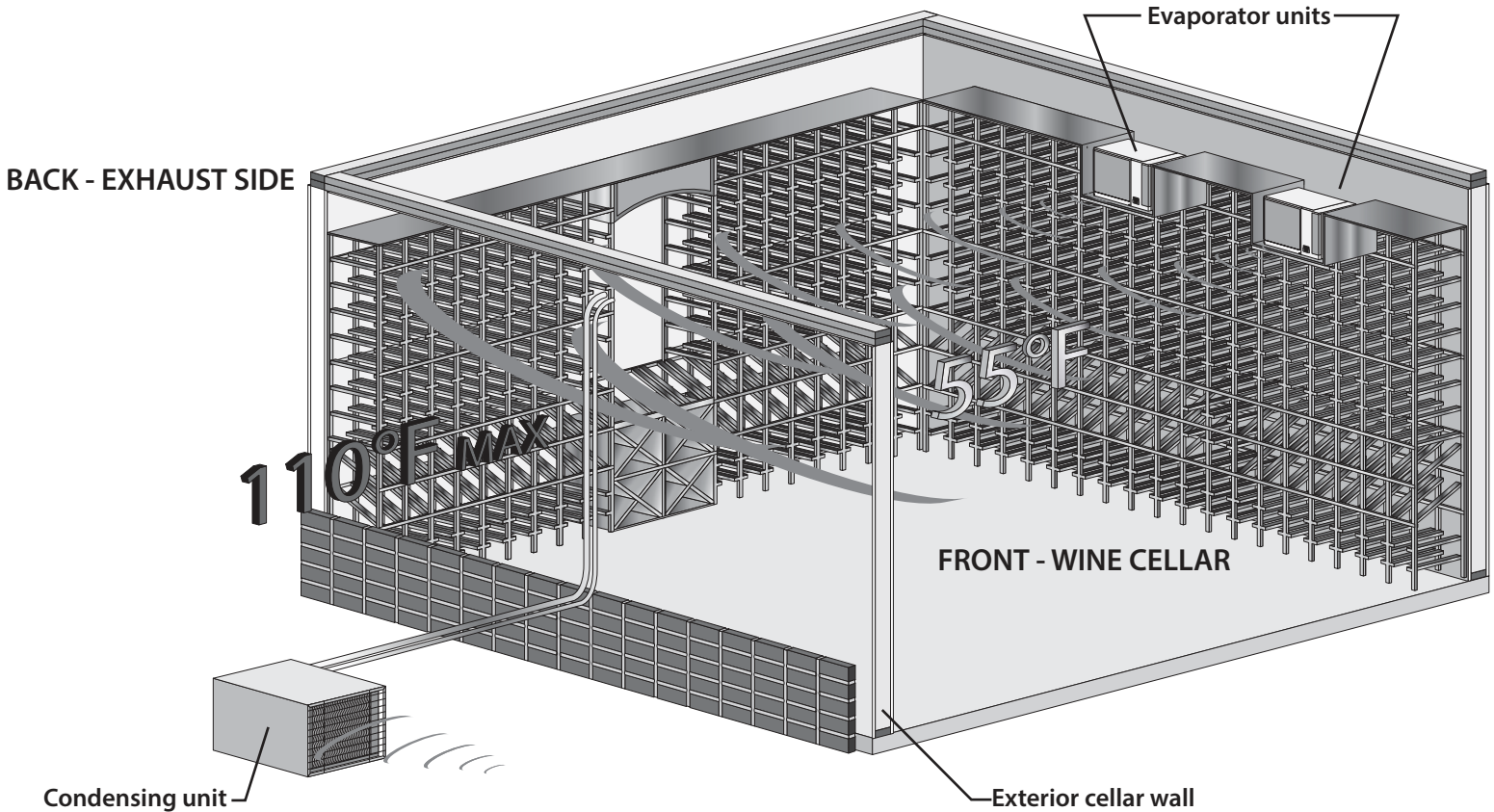

## Ambient Temperature Factor

The cooling system has the ability to cool a wine cellar efficiently to 55°F as long as the ambient temperature of the area that it is exhausting to does not exceed 110°F. Therefore, you want to exhaust the condensing unit in a space which will not exceed 110°F. Otherwise the system will not have the capacity to keep the wine at a desirable 55°F.



**WARNING! Allowing your system to operate in high ambient temperatures for extended periods of time will greatly decrease the life of your system and void your warranty. The cooler the temperature of the air entering the condenser coil, the more cooling capacity the system has. The less heat gain through the common wall, the less the electricity consumption.**



## SYSTEM OPERATION

*The cooling system is equipped with the hardware needed to support a 24-volt air conditioning thermostat (not included).*

### Initial Start-Up

Set the thermostat to COOL and fan switch to AUTO. Lower the setpoint to the desired cellar temperature. (A temperature of 55°F is the recommended setpoint.) See thermostat instructions for details.

### Normal System Cycle

The thermostat should turn the cooling system on when it senses a temperature one (1) degree higher than the setpoint. See thermostat instructions for details.

### Anti-Short Cycle

Most thermostats have a safety feature that will prevent the condensing unit from cycling on and off within a short period of time. During the anti-short cycle, the condensing unit will typically remain off for 5-7 minutes. See thermostat instructions for details.

### Fan Operation

If the fan switch on the thermostat is in the AUTO position, it will run only during the cooling cycle. If the fan switch on the thermostat is in the ON position, the fan will continuously run until the switch is set back to the AUTO position.

### Operation in Low Ambient Temperatures

The condensing unit comes equipped with a LAC (Low Ambient Control). The LAC is a three-way modulating valve that responds to discharge pressure. When the discharge pressure falls below the valve's dome pressure, the valve modulates open to the discharge port which allows discharge gas to bypass the condenser. Mixing the discharge gas with the liquid creates high pressure at the condenser outlet, reducing the flow and causing liquid to backup in the condenser. Flooding the condenser reduces the area available for condensing. This reduction in condenser surface area results in a rise in condensing pressure during cold ambient conditions.



The condensing unit controller is preset at the factory. The cut-in pressure is preset to 25psi and the cut-out pressure at 15psi. During low ambient temperatures (40°F or below), it will be necessary to adjust the cut-in pressure to 10-15psi (15psi is preferred) and the cut-out to 5psi to ensure compressor startup. See page 14 for instructions on adjusting the cut-in and cut-out pressures of the condensing unit.

**NOTE:** To ensure correct system operation, the 24V thermostat must be placed inside the wine cellar, preferably in a central location away from any airflow.

# Emerson<sup>™</sup> Electronic Unit Controller

## Quick setup and troubleshooting guide

### Adjusting Low Pressure Settings

Hold DOWN and SET simultaneously for 3 seconds to enter menu (PSI light will flash)  + 

Cycle through menu options – UP/DOWN  

Select function – SET 

Adjust value – UP/DOWN  

Store function - SET 

Exit menu - UP and SET  + 



Low Pressure Cut-In



Low Pressure Cut-Out



### Accessing Alarm Code Information

Press and release ALARM 

Cycle through menu options – UP/DOWN  

Press SET to see number of alarms 

Press SET again to return to menu options 

Exit menu - UP and SET  + 

Alarm	Description
PoF	Keypad locked
Pon	Keypad unlocked
P1	Suction probe failure
P2	Condenser probe failure
P3	DLT probe failure
HA	High condenser temperature alarm
dLt	DLT temperature alarm
dLL	DLT lock alarm
HP	High pressure trip alarm
HPL	High pressure trip lock-out alarm
EE	Module Failure
LOC	Number of lock-outs

Note: After 15 seconds of inactivity the controller will revert to the default display.

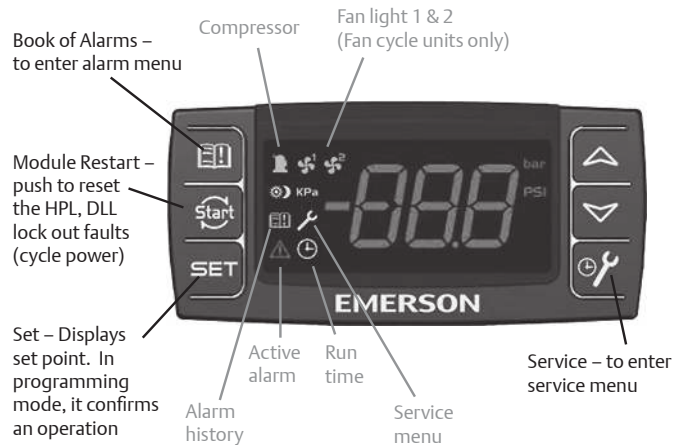

When light is on, feature or component is on or active



### Accessing Service Menu

Hold SERVICE for 3 seconds 

Cycle through menu options – UP/DOWN  

Press SET to see number of alarms 

Press SET again to return to menu options 

Exit menu - UP and SET  + 

Code	Description
StH	CompressorStarts –1000 -999999
StL	Compressor Starts –0 -999
CHH	CompressorHours -1000 -999999
CHL	Compressor Hours -0 -999
F1H	Fan 1 Hours -1000 -999999
F1L	Fan 1 Hours-0 -999
F2H	Fan 2 Hours -1000 -999999
F2L	Fand 2 Hours -0 -999

Example: If StH=12 and StL=500, the total number of compressor starts=12,500

For more information visit [EmersonClimate.com/ElectronicUnitController](http://EmersonClimate.com/ElectronicUnitController) or call 1-888-367-9950

Display	Likely Causes	Other Possible Causes
Controller display remains blank after applying power	<ul style="list-style-type: none"> <li>Unit power not properly applied - check for proper applied voltage</li> <li>Power cable harness not plugged in properly or securely into the back of the controller – check connections</li> </ul>	<ul style="list-style-type: none"> <li>Power cable miswired – inspect cable, replace if needed</li> <li>Electrical assembly miswired – trace wiring diagrams</li> </ul>
Controller displays correctly, but the green compressor light is off and the compressor is not running	<ul style="list-style-type: none"> <li>Jumper cable not plugged in properly or securely into the back of the controller – check connections</li> <li>Controller is currently above the cut-in setting – check cut-in and cut-out settings</li> </ul>	<ul style="list-style-type: none"> <li>Jumper cable miswired – inspect cable, replace if needed</li> </ul>
Controller displays correctly and the green compressor light is on and the compressor is not running	<ul style="list-style-type: none"> <li>Power cable harness not plugged in properly or securely into the back of the controller – check connections</li> </ul>	<ul style="list-style-type: none"> <li>Power cable not wired to the contactor or compressor correctly, check wiring</li> <li>Power cable miswired – inspect cable, replace if needed</li> </ul>
Controller flashes “135” or “P1”	<ul style="list-style-type: none"> <li>Current system pressure is above 135 PSIG – wait for system to pull down</li> <li>Green harness not plugged in properly or securely into the back of the controller – check connections</li> <li>Cable not connected properly with the pressure transducer – check connections</li> </ul>	<ul style="list-style-type: none"> <li>Transducer cable miswired – inspect cable, replace if needed</li> <li>Damaged transducer – inspect transducer, replace if needed</li> </ul>
Controller flashes “P2” on a unit with fan cycling	<ul style="list-style-type: none"> <li>Green harness not plugged in properly or securely into the back of the controller – check connections</li> </ul>	<ul style="list-style-type: none"> <li>Transducer cable miswired – inspect cable, replace if needed</li> <li>Check condenser temperature sensor resistance values against table in AE-1376, Section 8</li> </ul>
Controller flashes “P2” on a unit without fan cycling after replacing a controller	<ul style="list-style-type: none"> <li>Controller not programmed properly – check parameters in the advanced menu</li> </ul>	
Controller flashes “P3” on a unit with DLT	<ul style="list-style-type: none"> <li>Jumper cable not plugged in properly or securely into the back of the controller – check connections</li> </ul>	<ul style="list-style-type: none"> <li>Jumper cable miswired – inspect cable, replace if needed</li> <li>Faulty DLT temperature sensor – check the discharge line temperature sensor resistance values against table in AE-1376, Section 8</li> </ul>
Controller flashes “P3” on a unit without DLT after replacing a controller	<ul style="list-style-type: none"> <li>Controller not programmed properly – check parameters in the advanced menu</li> </ul>	
Fans not running on a fan cycling unit and the fan lights are not on	<ul style="list-style-type: none"> <li>Condensing temperature is currently below the fan cut-in</li> <li>Condensing temperature sensor not properly installed – check installation</li> </ul>	<ul style="list-style-type: none"> <li>Transducer cable miswired – inspect cable, replace if needed</li> <li>Faulty temperature sensor - check condenser temperature sensor resistance values against table in AE-1376, Section 8</li> </ul>
Fans not running on a fan cycling unit and the fan lights are on	<ul style="list-style-type: none"> <li>Power cable harness not plugged in properly or securely into the back of the controller – check connections</li> </ul>	<ul style="list-style-type: none"> <li>Power cable miswired – inspect cable, replace if needed</li> <li>Electrical assembly miswired – trace wiring diagrams</li> </ul>
Controller flashes “HP” at power-up	<ul style="list-style-type: none"> <li>Jumper cable not plugged in properly or securely into the back of the controller – check connections</li> <li>High pressure switch is seeing above the cut-out pressure</li> <li>For a replacing an -00 controller, ensure that the jumper cable is the latest revision. It should have a blue wire in the harness. See replacement instructions for more details</li> </ul>	<ul style="list-style-type: none"> <li>Jumper cable miswired – inspect cable, replace if needed</li> <li>Faulty fixed Hp switch – inspect switch, replace if needed</li> </ul>
Controller flashes “HP” or “HPL”	<ul style="list-style-type: none"> <li>System operation causing high discharge pressures, check system operations</li> </ul>	<ul style="list-style-type: none"> <li>Bad high pressure switch, verify system pressure when the pressure switch trips.</li> <li>See AE-1376, Section 7.2 for more details</li> </ul>
Controller flashes “DLT” or “DLL”	<ul style="list-style-type: none"> <li>System operation causing high discharge line temperatures, check system operations</li> </ul>	<ul style="list-style-type: none"> <li>Faulty temperature sensor - check DLT sensor values against table in section 8</li> <li>See AE-1376, Section 7.1 for more details</li> </ul>
Controller flashing “HPL” or “DLL”	<ul style="list-style-type: none"> <li>System operation causing high discharge pressures (HPL) or high discharge line temperatures (DLL) repeatedly, check system operations</li> <li>To clear an “HPL” or “DLL” lockout, you can hold the Restart button for 3 seconds twice, or cycle power to the unit. If using the reset button, the alarm condition will have to clear (DLT temperature drops or Hp switch resets), and any minimum off time will need to complete (5 minutes for the fixed Hp switch)</li> </ul>	

[EmersonClimate.com/ElectronicUnitController](http://EmersonClimate.com/ElectronicUnitController)

2013ECT-46 (9/13) Emerson is a trademark of Emerson Electric Co. ©2013 Emerson Climate Technologies, Inc. All rights reserved.

**EMERSON. CONSIDER IT SOLVED.™**



## WHISPERKOOL TROUBLESHOOTING GUIDE

<b>Ice forming on the evaporator units</b>	
<b>Possible cause</b>	<b>Solution</b>
Evaporator filters or coils are dirty	Remove the filters and wash them, then clean the coils with a vacuum. If coils are very dirty, use a spray bottle with a small amount of liquid dish detergent or coil cleaner. Spray coils, let set for five minutes, then flush with fresh water.
There is something blocking the supply and/or return air	Remove blockage
The evaporator fans are not turning on	Call customer service for details on how to perform the bypass plug test. If all components run correctly, and the system cools during the bypass plug test, there is either an issue with the 24V thermostat conversion kit or the thermostat. Contact customer service for further action.
If evaporator units continue to ice	Observe ice formation pattern. If only part way up the coil face, the system could be low on refrigerant. If all the way up, the coils may be dirty or airflow is blocked.
The setpoint is too low	Raise setpoint to recommended temperature of 55°F.
<b>Unit does not run/power up</b>	
<b>Possible cause</b>	<b>Solution</b>
Evaporator units are not plugged in	Make sure the units are plugged into an outlet
Power switch not on	Turn unit on by pressing the power button on the control
Line voltage rating is incorrect for the system	Check line voltage to make sure there is 110V-120V
Thermostat not calling for cooling	Adjust thermostat to a lower temperature
Faulty thermostat or wiring	Contact WhisperKool customer service
<b>Cellar temperature is too warm</b>	
<b>Possible cause</b>	<b>Solution</b>
The temperature of the room to which the condensing unit exhausts exceeds 110°F	Intake temperature needs to drop below 110°F
The system is undersized for the cellar	Order correctly sized system
There is something blocking the supply and/or return air on the evaporator units or the condensing unit	Remove airflow obstruction(s)
Evaporator units are mounted too low in the cellar	Relocate units so the distance from the ceiling and top of the units is no more than 18"
One or more of the fans is not turning on	Please contact the installing technician to troubleshoot
Compressor is not turning on	Please contact the installing technician to troubleshoot
Compressor keeps cycling on overload	Make sure all fans are working and there is no airflow obstruction
Poor seal around door or other areas requiring a seal (around the unit, wall joints, etc.)	Make sure there are no air gaps around the door. If door seal is damaged, replace it.
Thermostat set too high	Adjust thermostat to a lower temperature
Evaporator coils are frosted or iced up	Observe ice formation pattern. If only part way up the coil face, evaporator units could be low on refrigerant. If so, contact your installing technician to assist with troubleshooting.
<b>System runs constantly</b>	
<b>Possible cause</b>	<b>Solution</b>
Leaky door seal or poorly insulated cellar	Fix leaky door seal and insulate cellar

<b>Units leak water</b>	
<b>Possible cause</b>	<b>Solution</b>
Evaporator units are not level	Evaporator units should be level on the wall to prevent leaking
Drain lines clogged or kinked	Check drain lines to make sure water can flow freely
Drains are clogged, preventing water from escaping	Disconnect drains and clear them out; check drains for blockage
Drain lines do not have a downward slope	Fix drain lines so there is a downward slope from the units to the drains
Coils are iced, causing drain pans to freeze and water to overflow	Melt ice with blow drier. Soak up with a towel.
<b>System runs but does not cool</b>	
<b>Possible cause</b>	<b>Solution</b>
Lack of air flow	Make sure fans are unobstructed and that the evaporator filters, evaporator coils, and condenser coils are clean and free of debris
System undersized	Contact WhisperKool customer service
Compressor is overheating	Shut system off for 1 hour to allow compressor to cool. Turn back on and check for cooler air flow out. If compressor runs, check for and clean condenser coil as possible cause of compressor overheating. If problem repeats, contact you installing technician to assist with troubleshooting.
<b>Evaporator fan runs but compressor does not</b>	
<b>Possible cause</b>	<b>Solution</b>
Compressor and/or starting components faulty	Please contact the installing technician to troubleshoot
Compressor may have overheated	Shut system off for 1 hour to allow compressor to cool. Turn back on and check for cooler air flow out. If compressor runs, check for and clean condenser coil as possible cause of compressor overheating. If problem repeats, contact your installing technician to assist with troubleshooting.
Thermostat not sending power to Y terminal	Call customer service for details on how to perform bypass plug test
24V thermostat conversion kit solenoid relay not working correctly	Call customer service for details on how to perform bypass plug test
<b>Compressor runs but evaporator fan does not</b>	
<b>Possible cause</b>	<b>Solution</b>
Faulty fan motor	Please contact the installing technician to troubleshoot
Faulty thermostat	Please contact the installing technician to troubleshoot
<b>Compressor short cycles</b>	
<b>Possible cause</b>	<b>Solution</b>
Master evaporator unit's thermostat location	Move thermostat out of airflow
System low on refrigerant charge	Please contact the installing technician to troubleshoot
Condensing fan motor/capacitor faulty	Please contact the installing technician to troubleshoot
Compressor and /or starting components faulty	Please contact the installing technician to troubleshoot
<b>Humidity in cellar too low</b>	
<b>Possible cause</b>	<b>Solution</b>
Not enough moisture	Purchase and place a humidifier (or a decorative fountain) in cellar

Units equipped with the 24V Thermostat Conversion Kit:

<b>System does not power up/run</b>	
<b>Possible cause</b>	<b>Solution</b>
Batteries on thermostat have lost their charge	Change batteries
Thermostat wired incorrectly	Check wiring on 24V thermostat and correct
Wiring issue at master evaporator unit	Contact Customer Service for troubleshooting
24V transformer in master evaporator unit has failed	Contact Customer Service for troubleshooting
<b>Evaporator fans run continuously</b>	
<b>Possible cause</b>	<b>Solution</b>
Fan switch on thermostat set to "on"	Set fan switch to the "auto" position
Fan relay in thermostat or 24V conversion kit stuck on	Call Customer Service for details on how to perform the bypass plug test



## MAINTENANCE SCHEDULE

<b>Monthly</b>	<ol style="list-style-type: none"><li>1. Check coils</li><li>2. Check for unusual noise or vibration</li><li>3. Check the drain lines to see if they are above the waterline (if draining into a vessel)</li></ol>
<b>Quarterly</b>	<ol style="list-style-type: none"><li>1. Use a vacuum with brush attachment to clean coils; be careful not to crush coil fins when cleaning</li><li>2. Change duct filters if the system is ducted</li></ol>
<b>Annually</b>	<ol style="list-style-type: none"><li>1. Inspect for corrosion</li><li>2. Check wiring connections and integrity of cords</li><li>3. Pour a 50/50 bleach solution into the drain lines every spring</li></ol>

## TECHNICAL ASSISTANCE

WhisperKOOL Customer Service is available Monday through Friday from 6:00 a.m. to 4:00 p.m. Pacific Standard Time.

The appointed customer service representative will be able to assist you with your questions and warranty information more effectively if you provide them with the following:

- The model and serial number of your WhisperKOOL system(s).
- Location of unit and installation details, such as ventilation, ducting, construction of your wine cellar, and room size.
- Photos of the cellar and installation location may be needed.

### Contact WhisperKOOL Customer Service

1738 E. Alpine Ave  
Stockton, CA, 95205  
[www.whisperkool.com](http://www.whisperkool.com)

**Email:** [support@whisperkool.com](mailto:support@whisperkool.com)

**Fax:** 209-466-4606

Visit [www.emersonclimate.com/electronicunitcontroller](http://www.emersonclimate.com/electronicunitcontroller) for online brochures, bulletins, instruction videos, and general product information.

**Download the Copeland Mobile App on your mobile device for additional troubleshooting and technical information.**



## ACCESSORIES FOR COOLING UNITS

WhisperKOOL offers accessories to enhance and customize your wine cooling unit:

### UV Air Purification Upgrade

The optional UV air purification kit provides chemical-free cleaning of the air from germs and microbes, inhibits the growth of mold and bacteria inside the cooling system, and optimizes system performance and longevity.

### Condensate Pump Kit

The condensate pump kit automatically removes water that drips out of the evaporator unit's drain line. The pump is controlled by a float/switch mechanism that turns the pump on when approximately 2¼" of water collects in the tank, and automatically switches off when the tank drains to approximately 1¼". The condensate pump kit allows the excess condensate to be pumped up to 20 feet away from the unit.

### Exterior Housing

If the cooling unit is installed outside, it will need protection from sun, wind, and rain. The exterior housing protects the condensing unit portion of the split system from the elements when installed outdoors.

**Accessories can be purchased at [www.whisperkool.com](http://www.whisperkool.com)**

**WhisperKOOL Product Terms and Conditions**  
**Including Product Limited Warranty And Product Installation Requirements**  
**For WhisperKOOL Split System Series**

ATTENTION: PLEASE READ THESE TERMS OF USE CAREFULLY BEFORE INSTALLING YOUR WHISPERKOOL COOLING SYSTEM. INSTALLING YOUR WHISPERKOOL COOLING SYSTEM INDICATES THAT YOU ACCEPT AND AGREE TO EACH OF THE TERMS AND CONDITIONS SET FORTH HEREIN ("TERMS OF USE"). IF YOU DO NOT ACCEPT THESE TERMS OF USE, YOU RISK VOIDING YOUR WARRANTY AND ASSUMING ADDITIONAL REPAIR AND REPLACEMENT COSTS.

**1. Purchase of a WhisperKOOL Cooling System assumes that the Purchaser ("End User") fully accepts and agrees to the Terms and Conditions set forth in this document. The Terms and Conditions of Sale and Owner's Manual are shipped with each unit and, if another copy is needed, replacement copies can be downloaded from the company website (whisperkool.com) or by contacting WhisperKOOL directly for a new copy. WhisperKOOL reserves the right, in its sole discretion, to change its Terms and Conditions at any time, for any reason, without notice.**

**2. WhisperKOOL Product Installation and Limited Warranty**

- A. Purchaser of the product must arrange for the product to be installed by a certified HVAC/R technician in accordance with procedures set forth by WhisperKOOL and described in the WhisperKOOL Owner's Manual.
- B. The HVAC/R technician installing the product must complete the designated portion of the Split Startup Checklist and provide licensing or certification identification number information to assist in the warranty registration process.
- C. Purchaser must return the completed Split Startup Checklist to WhisperKOOL within thirty (30) days of installation of Product. The Split Startup Checklist must be approved by WhisperKOOL to activate the Limited Warranty. If the Split Startup Checklist is approved, Purchaser will be sent activation approval documents and will start receiving the benefits of the Limited Warranty throughout the warranty period. If the Split Startup Checklist is incomplete, Purchaser will be informed they have five days to complete the Split Startup Checklist and re-submit to WhisperKOOL. The Split Startup Checklist will be reviewed again, and if denied, Purchaser will be informed that they have 10 business days for corrective action. Failure to register the Product may result in loss of warranty.
- D. Purchaser is responsible for the full costs of installation and any additional parts required for the proper and complete installation of the product.
- E. For Split Systems returned to WhisperKOOL in accordance with the terms and conditions of the Limited Warranty, WhisperKOOL warrants against defects in material and workmanship as follows:
  1. **LABOR** — For a period of two (2) years commencing on the date of purchase, WhisperKOOL will, at its option and discretion, reimburse up to \$250 to the End User for cost incurred for servicing, repairing, removing or installing warranty parts. Invoice for service must be forwarded to WhisperKOOL for assessment and processing. The Split System warranty is invalid if there is attempted repair by anyone other than an HVAC/R technician approved by WhisperKOOL to service the Product.
  2. **PARTS** — For a period of two (2) years commencing on the date of purchase, WhisperKOOL will supply, at no charge, new or rebuilt replacement parts in exchange for defective parts. Replacement parts are warranted only for the remainder of the original warranty period.
  3. **FREIGHT** — For a period of two (2) years commencing on the date of purchase, if after WhisperKOOL approved evaluation the original Product failure is determined to be the cause of a manufacturers defect, and not the cause of an installation error or other cause, WhisperKOOL will cover at its option, freight for the replacement parts or Product.

**The following part or cause of failure is not the responsibility of WhisperKOOL:**

- Improper voltage supply
- Line set with screw connectors (high end and low end)
- Leaks found at the braze points when performing pressure check
- Unit that has been charged incorrectly

- Incorrect tubing diameter used on line set
- A unit that has been wired incorrectly
- Valve stem on condenser side
- Improper installation of P-Trap
- Lack of P-Trap (if required)
- Condensers that are installed outdoors or in elements that would affect operation without proper cover or housing. (Housing is available from Manufacturer).

**Product Warranty Limitations and Exclusions.**

1. This limited warranty does not cover cosmetic damage caused during installation, damage due to acts of God, commercial use, accident, misuse, abuse, negligence, or modification to any part of the Product. Delivery and installation of the Product, any additional parts required, as well as removal of the Product if warranty work is required, are all at the sole cost, risk and obligation of the End User.
2. This limited warranty does not cover damage due to improper installation or operation or lack of proper maintenance of the Product, connection of the Product to improper voltage supply, or attempted repair of the Product by anyone other than a technician approved by WhisperKOOL to service the Product.
3. This limited warranty does not cover any Product sold "AS IS" or "WITH ALL FAULTS."
4. Product that has been replaced during warranty period does not extend the warranty period past the original date of purchase.
5. This limited warranty is valid only in the continental United States. Sales elsewhere are excluded from this warranty.
6. Proof of purchase of the Product in the form of a bill of sale, receipted invoice or serial number, which is evidence that the Product is within the Limited Warranty Period, must be presented by the End User to WhisperKOOL in order to obtain limited warranty service.
7. This limited warranty is void if the factory applied serial number has been altered or removed from the Product.
8. This limited warranty is voided if installed in an enclosure of insufficient design that does not follow the Product installation requirements stated herein and in the owner's manual.
9. Removing the rivets from the Product's unit housing without prior authorization from WhisperKOOL voids this limited warranty.
10. The End User must first contact WhisperKOOL Customer Service prior to attempting service on any Product still under the limited warranty; else the limited warranty is voided.
11. This limited warranty does not cover Product being concealed by, but not limited to, vegetation, fabric, shelving, mud, snow, or dirt. Product must not be painted or limited warranty will be void.
12. This limited warranty does not cover exposure to corroding environments such as, but not limited to, petroleum and gasoline products, cleaning solvents, caustic pool chemicals, and marine air.
13. This limited warranty does not cover any cause not relating to Product defect.
14. THE REPAIR OR REPLACEMENT OF THE PRODUCT AS PROVIDED UNDER THIS LIMITED WARRANTY IS THE EXCLUSIVE REMEDY OF YOU, THE END USER, AS WELL AS ANYONE ELSE IN THE CHAIN OF TITLE OF THE PRODUCT, DOES NOT START A NEW LIMITED WARRANTY TIME PERIOD, AND IS IN LIEU OF ALL OTHER WARRANTIES (EXPRESS OR IMPLIED) WITH REGARD TO THE PRODUCT. IN NO EVENT SHALL WHISPERKOOL BE LIABLE FOR INCIDENTAL, CONSEQUENTIAL, SPECIAL OR CONTINGENT DAMAGES FOR BREACH OF ANY EXPRESS OR IMPLIED WARRANTY ON THIS PRODUCT. THE IMPLIED WARRANTIES OF MERCHANTABILITY
15. AND FITNESS FOR A PARTICULAR PURPOSE ARE HEREBY EXPRESSLY DISCLAIMED. Some states do not allow the exclusion or limitation of incidental or consequential damages, or allow limitations on how long an implied warranty lasts, so the above limitations or exclusions may not apply to you. This limited warranty gives you specific legal rights, and you may have other rights, which vary from state to state.
16. Failure of the End User to comply with all of the Product Installation Requirements, Maintenance Requirements and End User Requirements may, at WhisperKOOL's sole discretion, void this limited warranty.
17. No one has any authority to add to or vary the limited warranty on this Product.

### **3. Maintenance Requirements**

The End User is responsible for checking the coils on the condenser unit and vacuuming them every three months to maintain them free of debris. It is the End User's responsibility to clean off any accumulated dust, lint, or other debris from the front and rear intake grills; failure to do this on a regular basis will restrict the airflow and may affect the Product's ability to function properly. Periodically cleaning the Product's vents will help assure maximum cooling efficiency. The drain tube must also be checked and kept clean and free of debris and mold to maintain proper performance.

Mold is a natural living organism in the environment. It exists in the air in the form of microscopic spores that move in and out of buildings through doors, windows, vents, HVAC systems and anywhere else that air enters. Once it is discovered, mold must be addressed quickly and appropriately. Delayed or improper treatment of mold issues can result in costly and reoccurring repairs. If the End User suspects a mold problem, it is always best to hire a qualified and experienced mold remediation specialist.

### **4. Additional End User Costs And Responsibilities**

#### **Terms and conditions for replacing the Product that is being evaluated for limited warranty.**

1. After evaluation by a certified HVAC/R technician and the Product is found to be irreparable in the field, contact WhisperKOOL Customer Service to arrange for replacement under the warranty guidelines. When a claim for warranty is submitted for a condenser skid, the End User must purchase a new condenser skid from WhisperKOOL at retail price. Upon installation of the new condenser skid by a certified HVAC/R Technician, the HVAC/R Technician must complete the Installation Checklist and End User must submit the Installation Checklist to WhisperKOOL Customer Service for approval. The original condenser skid must be returned within 21 days to WhisperKOOL for failure analysis. If the Installation Checklist is approved and the failure is evaluated as defective and not installation error or other reason, the End User will be refunded for the cost of the replacement skid.
2. If the Product failure is evaluated and it is determined that it is an installation error or other reason, all costs, including shipping will be the responsibility of the End User.

The following items are not covered under any warranty and are the sole responsibility of the End User:

- A. End Users should satisfy themselves that the Product they are purchasing is suitable for their particular needs and requirements, and thus no responsibility will be placed with WhisperKOOL for the End User's decisions in this regard.
- B. End Users must assure that the product is installed by a certified HVAC/R technician. Failure to do so will result in Voiding the Limited Warranty.
- C. It is the End User's responsibility to secure safe haven/storage for ANY AND ALL items that are being kept and stored in the End User's wine cellar, including any Product. WhisperKOOL takes no responsibility for the safety and preservation of the aforementioned items in the event that the environment becomes unsuitable to maintain a proper storage environment.
- D. End User is responsible for initial installation costs, including, but not limited to, labor costs and the cost of any additional parts necessary to complete the installation.
- E. End User is responsible for all costs incurred for the installation and/or removal of the Product, or any part thereof, unless such cost has been agreed by WhisperKOOL to be a warranty repair prior to the work being performed.

### **5. Sales and Use Tax**

WhisperKOOL only collects California sales tax for orders shipped within the State of California; WhisperKOOL does not collect sales tax for orders shipped to other states. However, the Purchaser and the End User may be liable to the taxing authority in their state for sales tax and/or use tax on the Product. The Purchaser and the End User should each check with their state's taxing authority for sales and use tax regulations.

### **6. Customer Service and Troubleshooting**

WhisperKOOL's customer service department is available to answer any questions or inquiries for End Users regarding a WhisperKOOL Product, as well as to assist in performing basic troubleshooting, Monday through Friday, from 6:00 a.m. to 4:00 p.m. PST, at [support@WhisperKOOL.com](mailto:support@WhisperKOOL.com). WhisperKOOL reserves the right to have a certified, WhisperKOOL-approved, HVAC/R technician go on site and inspect the product if the initial trouble shooting warrants further investigation. WhisperKOOL Corporation is located at 1738 East Alpine Avenue, Stockton, California 95205.

## 7. Request for Product Evaluation and Repair Under Warranty

**SPLIT SYSTEM FIELD SERVICE WARRANTY POLICY:** This Policy is to clarify what falls under Warranty Service and what becomes the responsibility of the Owner. WhisperKOOL (“manufacturer”) strives to provide our customers with a superior Product and we back our Product with a Two Year Limited Warranty. Please review the WhisperKOOL Product Terms and Conditions including Product Limited Warranty and Product Installation Requirements to ensure you have a complete understanding of our Policy and coverage of your Split System.

**ARBITRATION:** Any disputes arising out of or in connection with the installation and warranty of the Split System shall be referred to and finally resolved by a WhisperKOOL approved Independent Certified HVAC/R Technician. The evaluation of the Technician on all issues or matters of identifying the responsible party (WhisperKOOL or Installing Technician) shall be determined in a written report. This report will be made available to all concerned parties. If discovered under warranty, WhisperKOOL will assume the financial responsibility under their warranty guidelines. If the report finds the Owner’s Installer as the responsible party, WhisperKOOL will provide all documentation to the customer to substantiate the findings. This will include the Invoice from the Independent Certified HVAC/R Technician and the written report of the findings. The Owner will become responsible for payment directly to WhisperKOOL for all charges incurred for repairs (labor, parts and shipping costs) on the Split System.

## 8. Miscellaneous Terms and Conditions

- A. Return Policy. All return inquiries must be made within thirty (30) calendar days of the original purchase of a Product and are subject to a twenty five percent (25%) restocking fee. Shipping costs are not refundable and the Purchaser is responsible for all return shipping costs (including customs fees and duties, if applicable).
- B. Security Interest. WhisperKOOL retains a security interest in each Product until payment in full.
- C. Construction and Severability. Every provision of these Terms and Conditions shall be construed, to the extent possible, so as to be valid and enforceable. If any provision of these Terms and Conditions is held by a court of competent jurisdiction to be invalid, illegal or otherwise unenforceable, such provision will, to the extent so held, be deemed severed from the contract of sale between Purchaser and WhisperKOOL, and all of the other non-severed provisions will remain in full force and effect.
- D. Governing Law/Choice of Forum. The laws of the State of California (without regard for conflicts of law) shall govern the construction and enforcement of the these Terms and Conditions of Sale (Sections 1 through 9 inclusive, including Product Limited Warranty And Product Installation Requirements), and further these Terms and Conditions of Sale shall be interpreted as through drafted jointly by WhisperKOOL and Purchaser. Any dispute will be resolved by the courts in and for the County of San Joaquin, State of California, and all parties, WhisperKOOL, Purchaser and End User, hereby irrevocably submit to the personal jurisdiction of such courts for that purpose. No waiver by WhisperKOOL of any breach or default of the contract of sale (including these Terms and Conditions of Sale) concerning a Product will be deemed to be a waiver of any preceding or subsequent breach or default.
- E. Correction of Errors and Inaccuracies. These Terms and Conditions may contain typographical errors or other errors or inaccuracies. WhisperKOOL reserves the right to correct any errors, inaccuracies or omissions, and to change or update these Terms and Conditions, at any time without prior notice.

## 9. Questions, Additional Information And Technical Assistance

- A. Questions. If you have any questions regarding these Terms and Conditions or wish to obtain additional information, contact us at [support@WhisperKOOL.com](mailto:support@WhisperKOOL.com) or please send a letter via U.S. Mail to:

Customer Service  
WhisperKOOL Corporation  
1738 E Alpine Ave  
Stockton, CA 95205

E-mail: [support@whisperkool.com](mailto:support@whisperkool.com)  
Web: [www.whisperkool.com](http://www.whisperkool.com)

- B. Technical Assistance. WhisperKOOL Customer Service is available Monday through Friday from 6:00 a.m. to 4:00 p.m. PST. The Customer Service representative will be able to assist you with your questions and warranty information more effectively if you provide them with the following:
  - 1. The model and serial number of your WhisperKOOL UNIT.
  - 2. The location of the system and installation details, such as ventilation, construction of your wine cellar, and room size.

**Model** \_\_\_\_\_ **Serial Number** \_\_\_\_\_

**Installed by** \_\_\_\_\_ **Date** \_\_\_\_\_

*Whisper***KOOL**<sup>™</sup>

WhisperKOOL  
1738 E. Alpine Ave  
Stockton, CA 95205  
[www.whisperkool.com](http://www.whisperkool.com)



***PLATINUM SPLIT TWIN***  
**VERSION 5**  
**TECHNICIAN'S MANUAL**

*24V Thermostat Conversion Kit Option*

*Whisper***KOOL**<sup>TM</sup>  
*The Coolest Thing In Wine Storage*

**Conforms to ANSI/UL Std 427**

**Certified to CAN/CSA Std C22.2 No. 120**

***We manufacture, test and certify 100% of our wine cooling units in the USA. By sourcing the best components and closely controlling our manufacturing processes, we can assure the highest-quality, lowest defect manufacturing rates in the industry.***

Copyright © 2017. WhisperKOOL. All rights reserved.

WhisperKOOL copyrights this manual, the product design, and the design concepts, with all rights reserved. Your rights with regard to the hardware and manual are subject to the restrictions and limitations imposed by the copyright laws of the USA. Under copyright laws, this manual may not be copied, reproduced, translated, transmitted, or reduced to any printed or electronic medium or to any machine-readable form, for any purpose, in whole or in part, without the written consent of WhisperKOOL.

Every effort has been made to ensure that the information in this manual is accurate. WhisperKOOL is not responsible for printing or clerical errors.

WhisperKOOL reserves the right to make corrections or improvements to the information provided and to the related hardware at any time, without notice.

Vinothèque and WhisperKOOL are registered trademarks, and ECE is a trademark of WhisperKOOL. All rights reserved.

Mention of third-party products is for informational purposes only and constitutes neither an endorsement nor a recommendation. WhisperKOOL assumes no liability with regard to the performance or use of these products.

# TABLE OF CONTENTS

<b>Introduction</b> .....	2
<b>Quick Start Guide</b> .....	3
<b>Before You Start</b> .....	4
<b>Receiving &amp; Inspecting the System</b> .....	5
<b>Quick Reference Guide</b>	
Wall-Mounted Twin Evaporator .....	6
Fully Ducted Twin Evaporator .....	7
Wall-Mounted Platinum Split Twin: Unit Specifications .....	8
Ducted Platinum Split Twin: Unit Specifications .....	9
Condensing Unit Quick Reference Guide .....	10
<b>Evaporator Installation</b>	
24V Wiring Connections .....	12
Preparing the Wall-Mounted Evaporator Units .....	13
Installing the Wall-Mounted Evaporator Units .....	14
Preparing the Fully Ducted Evaporator Units .....	16
Installing the Fully Ducted Evaporator Units .....	17
<b>Ducting Overview</b> .....	18
<b>Ducting Configurations</b> .....	19
<b>Drain Line</b> .....	20
<b>Wiring Diagrams</b>	
Platinum Split Twin with 24V Thermostat Conversion Kit .....	21
Platinum Split Twin Master Evaporator with 24V TCK .....	22
Platinum Split Twin Slave Evaporator with 24V TCK .....	23
Platinum Split Twin 9000 Condensing Unit .....	24
Copeland Cold Weather Start Kit .....	25
<b>Preparing the Condensing Unit</b> .....	25
<b>Installing the Condensing Unit</b> .....	26
<b>Line Set Piping Diagram</b> .....	27
<b>Installing the Ducted Plenum</b> .....	30
<b>System Operation</b> .....	35
<b>WhisperKOOL Troubleshooting Guide</b> .....	38
<b>Maintenance Schedule</b> .....	41
<b>Bypass Test Procedure</b> .....	43
<b>Technical Assistance &amp; Accessories</b> .....	44
<b>Installation Terms and Conditions</b> .....	45

## INTRODUCTION

### Customer Service

Thank you for purchasing a WhisperKOOL cooling system. We strive to provide the highest-quality products and the best possible customer service. If you have any questions about your system, please visit [WhisperKOOL.com](http://WhisperKOOL.com).

### Using the Manual

This manual is intended to assist in the proper maintenance of the cooling system. In order to ensure the longevity of your cooling unit, the equipment should be installed as outlined in the technician's manual. It is also vital to establish a proper care and maintenance schedule. Please read and review this manual carefully and keep it for future reference.

### What is the WhisperKOOL Cooling System?

The WhisperKOOL cooling system is a specialized refrigeration system designed for one purpose only: to maintain the optimal temperature and humidity levels conducive to the proper storage and aging of fine wines. This system produces minimal in-cellar noise and has the most lenient exhaust requirements. An exterior housing is required for outdoor condensing unit installations.

### How Does the Cooling System Work?

Similar to the air conditioning systems used for homes, the evaporator unit and condensing units are installed in separate locations and are connected by a refrigerant line set. The evaporator portion is commonly installed in the wine cellar, with the condensing unit located either outside or in a remote indoor location that is ventilated. An exterior housing is required for outdoor condensing unit installations.

### Temperature Setting

The system is designed to maintain a cellar temperature of 55°F as long as the ambient temperature does not exceed 110°F.

## WARRANTY REGISTRATION

In order to activate the warranty of your system, the verification and operational documentation must be completed by the certified refrigeration technician installing your system and submitted via mail, fax, or e-mail.

Mail to:  
WhisperKOOL  
ATTN: Warranty Registration  
1738 E. Alpine Avenue  
Stockton, CA 95205-2505  
USA

Fax to:  
209-466-4606

Scan and email to:  
[warranty@whisperkool.com](mailto:warranty@whisperkool.com)

# QUICK START GUIDE\*

## Pump-down Cycle

WhisperKOOL's split systems operate on a pump-down cycle different from traditional air conditioners. As such, there is no wiring between the condensing unit and evaporator unit.

WhisperKOOL units utilize a solenoid valve on the liquid line and a low-pressure switch on the suction line. When the thermostat calls for cooling, the solenoid valve opens, permitting the flow of refrigerant. The low-pressure switch then signals the compressor to cycle on.

When the cellar reaches the desired temperature and the thermostat is satisfied, the solenoid will close, stopping the liquid refrigerant flow to the TXV valve. The compressor will continue to operate until most of the refrigerant on the low side boils off and is pumped through the compressor into the condenser coil and receiver. As the suction pressure falls below the pressure control setting, the low-pressure switch will signal the compressor to cycle off. Most of the refrigerant is now stored between the condensing unit and receiver.



**WARNING:** Do not utilize a ground fault interrupter, as it will prevent the unit from drawing the amperage necessary to start the unit.



## TXV Adjustments

- A. A TXV adjustment may be necessary based on ambient temperatures in the cellar and at the condensing unit.
- B. Adjust the TXV until the superheat measured at the suction line service valve is 20-30°F.
- C. Under normal operation, with the wine cellar at 55°F and the ambient temperature at 85°F, the low side pressure should be between 28-32 PSI and the high side should be between 160-180 PSI.

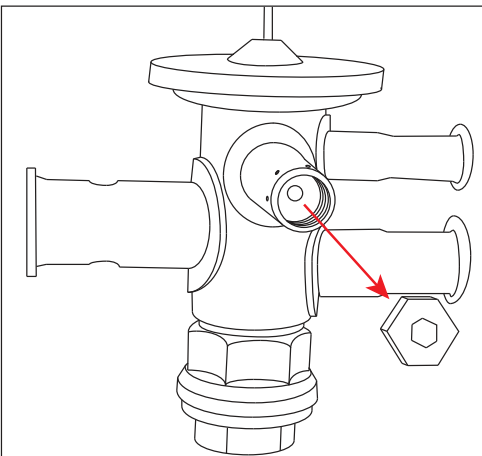
<p style="text-align: center;"><b>TXV</b></p> <p>The TXV is preadjusted at the factory. If the superheat is not within 20-30° at the service valve, the TXV will need to be adjusted.</p> <p style="text-align: center;"><b>ADJUSTING THE TXV</b></p> <p>Use a 5/32" hex key to remove the cap from the TXV superheat adjustment port. With the cap removed, insert the hex key into the superheat adjustment port. Increase superheat by turning the hex key clockwise. Decrease superheat by turning the hex key counterclockwise.</p>	
--	--

<p><b>Liquid Line King Valve</b></p> <p>This location is used to charge the system with liquid refrigerant and identify the high side pressure of the system.</p> <p><b>Calculating Subcooling</b></p> <p>To determine the subcooling of the system, calculate the difference between the <b>high side pressure of the system (converted to temperature)</b> and the <b>temperature of the liquid line</b>. The temperature of the liquid line will be taken at the outlet of the receiver.</p> <p>*Saturation temp — liquid line temp</p> <p style="color: red; font-weight: bold; margin-top: 10px;">4-6°F SUBCOOLING REQUIRED FOR WARRANTY APPROVAL</p>
--

\*Further system operation information is available on page 35.

## BEFORE YOU START

1. **Inspect all components prior to installation.** If damage is found, please contact your distributor or WhisperKOOL Customer Service at support@WhisperKOOL.com.
2. Each evaporator unit **requires a dedicated 115V, 15-amp circuit.** The condensing unit **requires a dedicated 230V single-phase 15-amp circuit.** Use a surge protector with the unit. **Do not use a GFI** (ground fault interrupter) line.
3. You are **REQUIRED** to **install a drain line** to remove condensation from each evaporator unit.
4. ***The warranty is not active until a warranty checklist has been received, reviewed, and approved.***
5. The system is intended **for use in properly designed and constructed wine cellars.** Hire a professional wine storage consultant with a valid contractor's license to build your wine cellar.
6. WhisperKOOL requires that all split systems be installed by a certified HVAC-R technician only. NATE or equivalent is recommended.
7. ***It is vital that the units be set apart and oriented so that the return air from one unit does not recirculate into the supply air of the other unit.***

If you encounter a problem with your WhisperKOOL system, please refer to the Troubleshooting Guide. If you have any further questions or concerns, or need assistance, please contact WhisperKOOL's Customer Service at support@WhisperKOOL.com. Please be sure all testing has been completed prior to contacting Customer Service. Please have your results ready for your representative.

# RECEIVING & INSPECTING THE SYSTEM

- Use caution when lifting and check package for damage.
- Lift only at the designated hand-hold locations on the shipping container, or fully support the unit from underneath. A shipment may include one or more boxes containing accessories.
- Before opening the container, inspect the packaging for any obvious signs of damage or mishandling.
- Write any discrepancy or visual damage on the bill of lading before signing.
- Allow the condensing unit to sit for 24 hours prior to start-up. The condensing unit can be placed in the installation location, piped, and evacuated during this time.

**NOTE:** WhisperKOOL units are manufactured in the USA and tested prior to shipment.

- Review the packing slip to verify contents.
- Check the model number to ensure it is correct.
- Check that all factory options ordered are listed.

**If any items listed on the packing slip do not match your order information, contact WhisperKOOL Customer Service immediately.**

**Check all shipped boxes for the following contents:**

### Master Evaporator Box

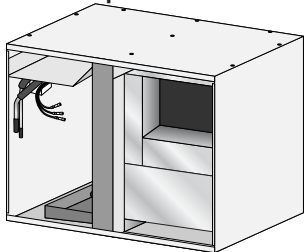

- (1) Master Platinum Split Twin evaporator unit
- (1) Wall-mounted evaporator installation template

*Documentation bag (master):*

- Platinum Split Twin owner's manual
- Platinum Split Twin technician's manual
- R-134a split system warranty checklist

*Evaporator installation hardware bag (master)*

- (2) 1/2" x 1/2" 90° nylon barbed fitting
- (1) 1/2" barbed tee
- (1) Double-D strain relief
- (4) 3/4" adhesive cable tie mounts
- (2) Small cable ties
- (4) #8 x 1 3/4" hex-head screws

### Slave Evaporator Box

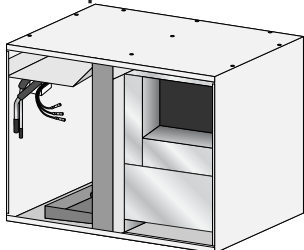

- (1) Slave Platinum Split Twin evaporator unit
- (1) Wall-mounted evaporator installation template
- (1) Evaporator installation hardware bag

- (2) 1/2" x 1/2" 90° nylon barbed fitting
- (1) 1/2" barbed tee
- (1) Double-D strain relief
- (4) 3/4" adhesive cable tie mounts
- (2) Small cable ties
- (4) #8 x 1 3/4" hex-head screws

### Ducted Master Accessory Kit Box

(1) Duct plenum

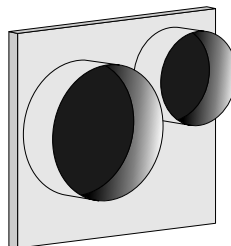

### Wall-Mounted Master Accessory Kit Box

(1) Filter grille

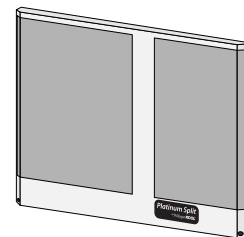

OR

### Ducted Slave Accessory Kit Box

(1) Duct plenum

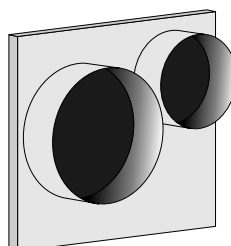

### Wall-Mounted Slave Accessory Kit Box

(1) Filter grille

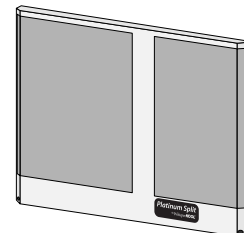

OR

### Condensing Unit Box

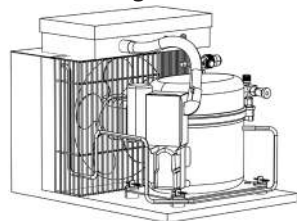

- (1) Condensing unit
- (1) Condensing unit accessory kit:
  - (1) 1/4" filter drier
  - (1) 1/4" sight glass

Please leave the unit in its original box until you are ready for installation. This will allow you to move the product safely without damaging it. When you are ready to remove the product from the box, refer to the installation instructions.

**TIP:** Save your box and all packaging materials. They provide the only safe means of transporting/shipping the unit.

## QUICK REFERENCE GUIDE

### Front / Side View

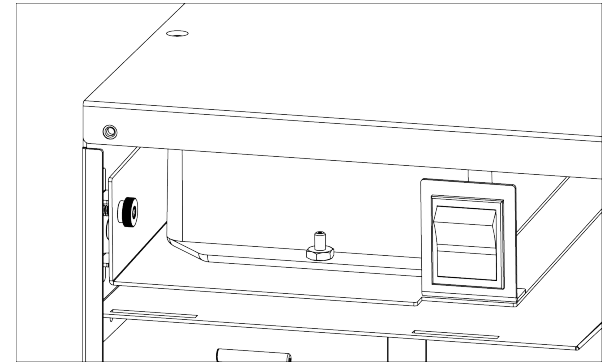
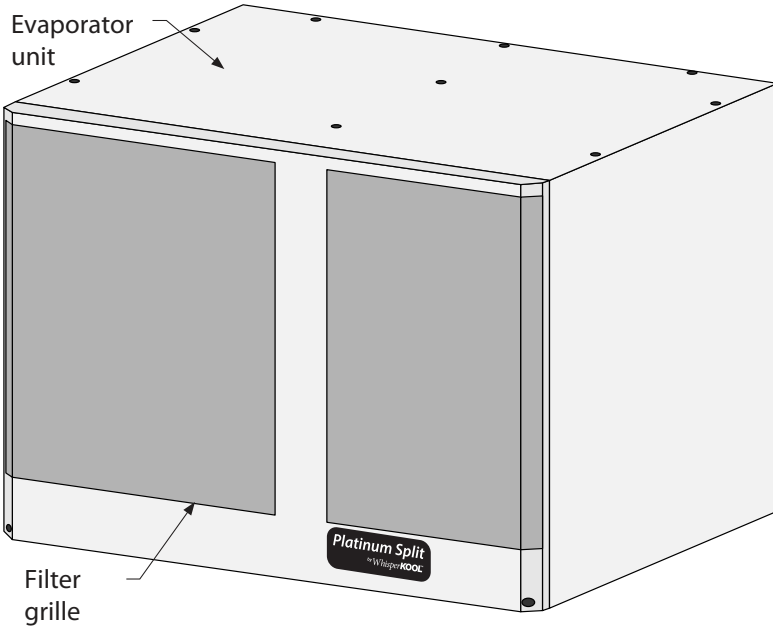

### Fan Speed Switch

The cooling system comes equipped with a variable fan speed switch. Increasing the fan speed increases the volume of cool air blown from the system. It is set by the factory to MED. To access the fan speed switch it is necessary to remove the front grille.

### Wall-Mounted — Rear / Side View

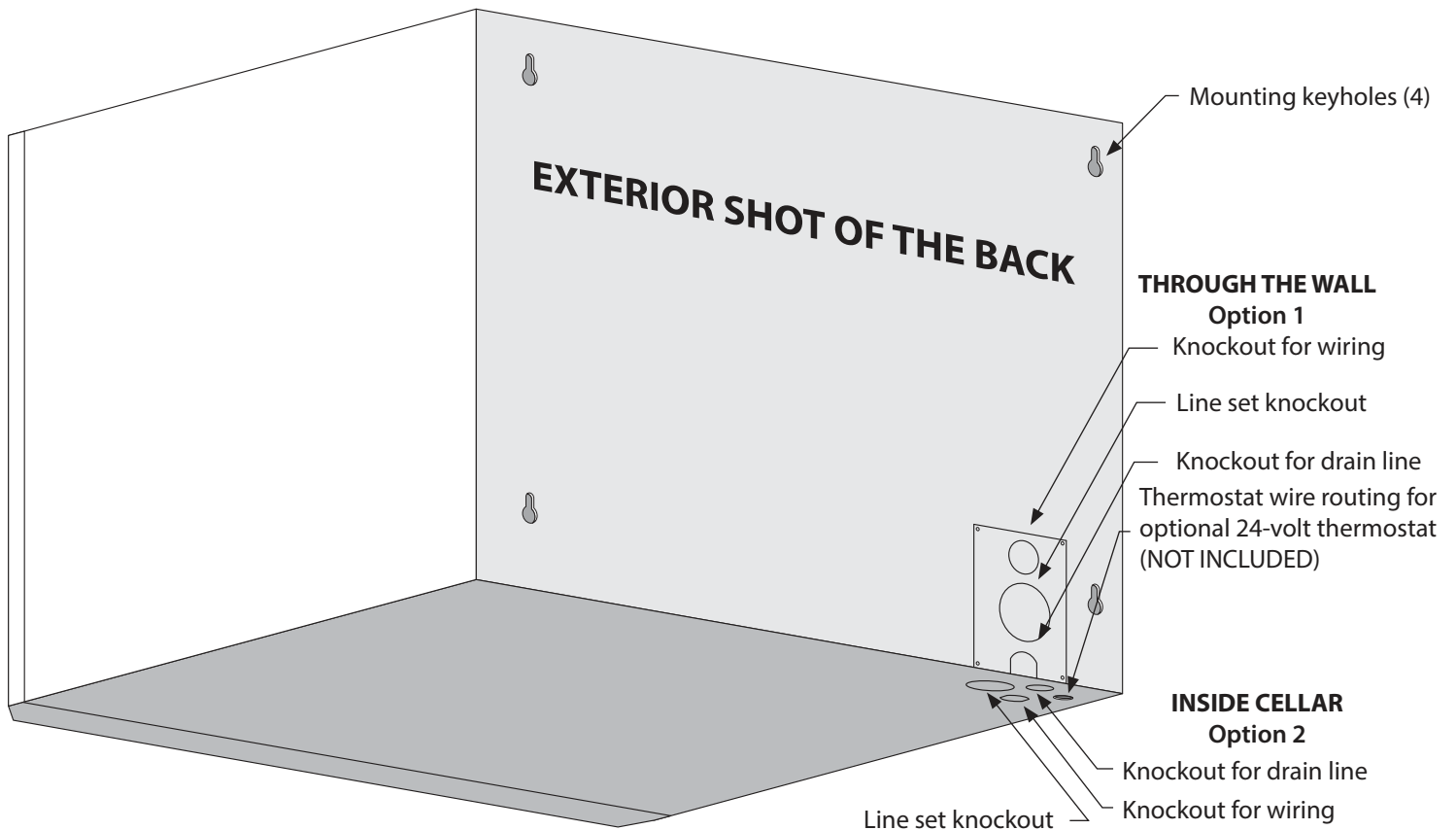



Fully Ducted — Front / Side View

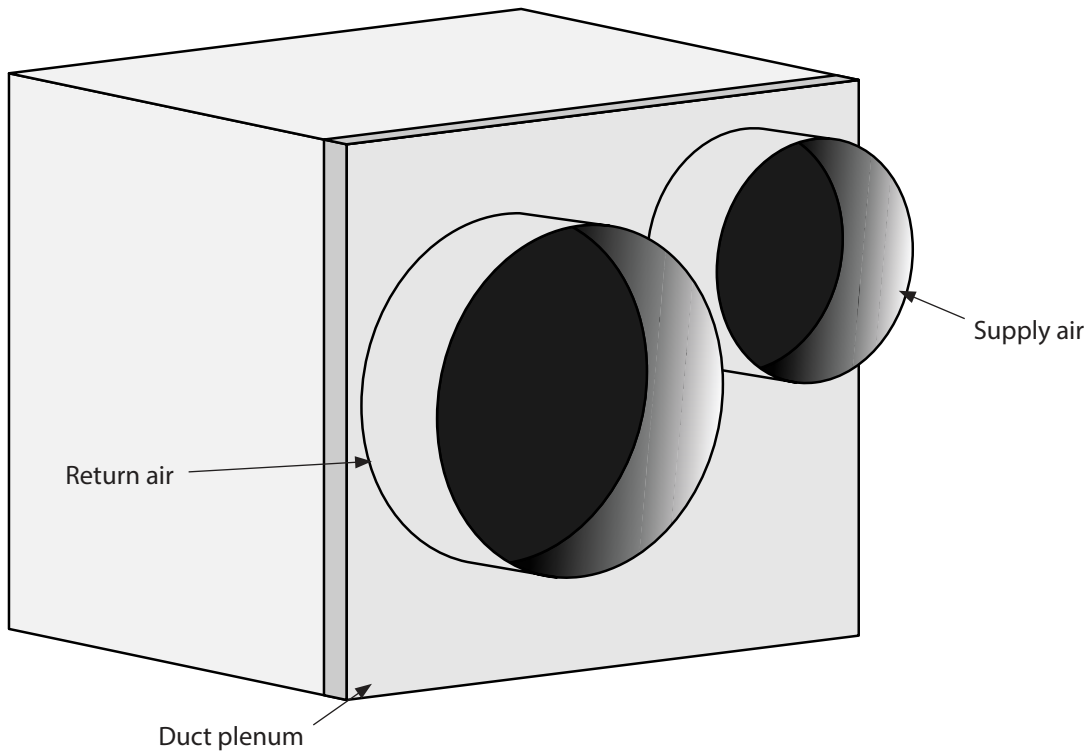

Fully Ducted — Rear / Side View

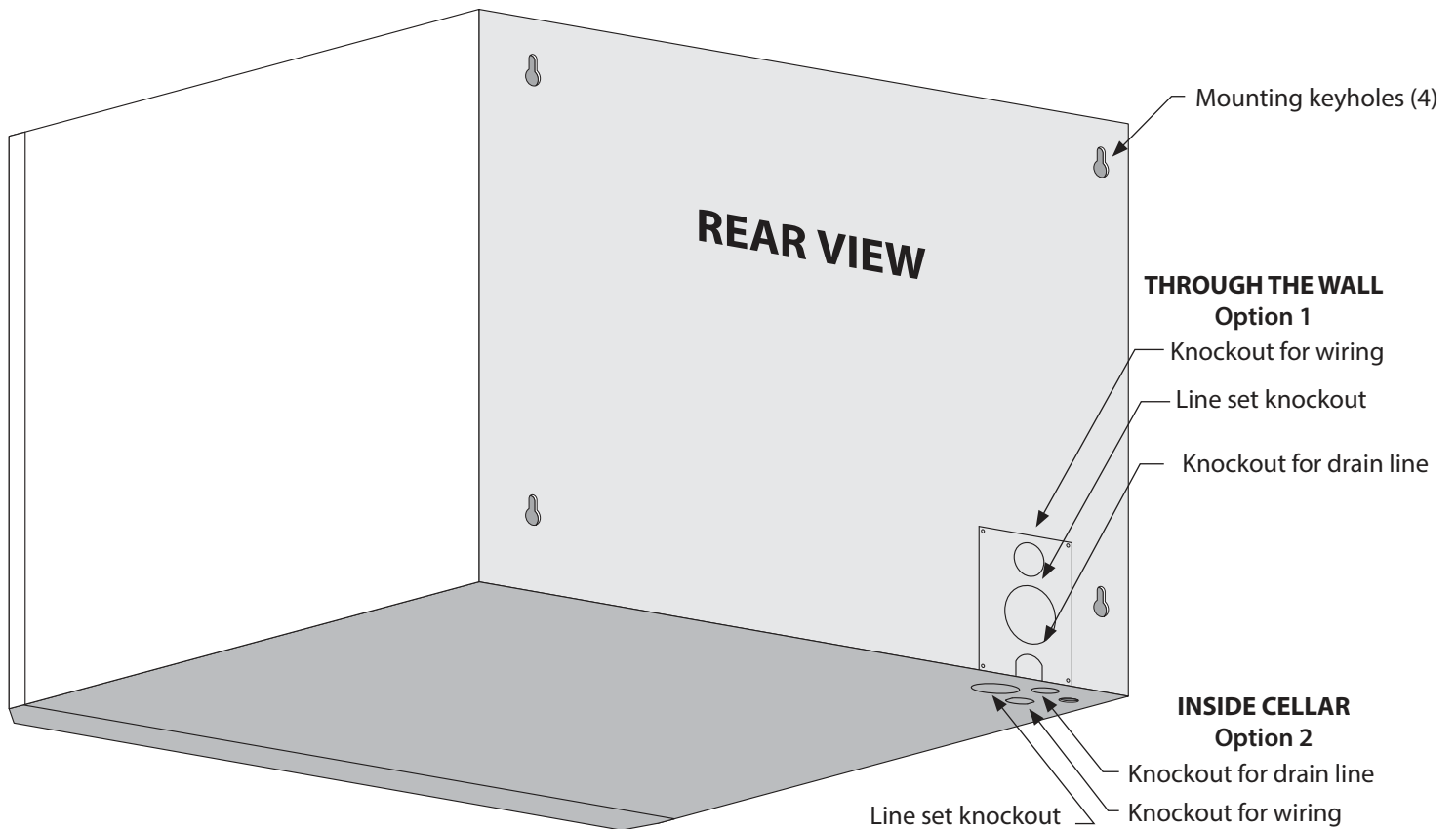

## WALL-MOUNTED TWIN SPECIFICATIONS

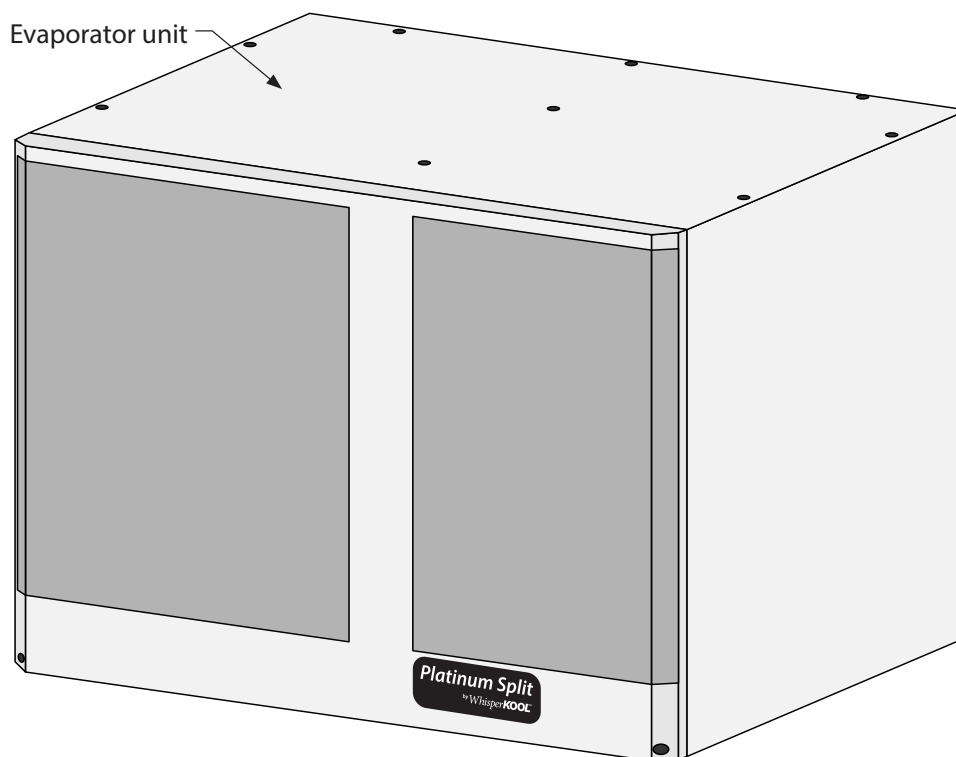

Model	9000 Master Evaporator (Fan Coil Unit)	9000 Slave Evaporator (Fan Coil Unit)
Cellar Size	Approx. 3000 cu. ft., provided cellar is fully insulated and sealed with proper vapor barrier*	
BTU/h w/85°F air entering condenser coil	Low: 6843/7845 • Medium: 7368/7959 • High: 7779/8054	
Dimensions	16.1"L x 20.5"W x 15.5"H	16.1"L x 20.5"W x 15.5"H
Refrigerant	R-134a	R-134a
Voltage Rating	115V (15-amp dedicated circuit required)	115V (15-amp dedicated circuit required)
Weight (lbs)	57	57
Amps	Evaporator: 1 running amp (per unit) Compressor: LRA 50, RLA 9.3	Evaporator: 1 running amp (per unit) Compressor: LRA 50, RLA 9.3
Line Set	Liquid line 3/8"; suction line 3/4" (less than 50 ft.), 7/8" (greater than 50 ft.)	
Drain Line	1/2" ID clear plastic tubing (not provided)	
Installation	Evaporator units are installed in the cellar.	
Thermostat	Advanced digital display (50-ft. cable), liquid-temperature-measuring bottle probe (50-ft. cable)	
Temp. Delta	Can maintain a 55°F temperature differential with up to 110°F condenser air intake temperature	
Warranty	Two-year limited warranty (parts and labor)	

\*Each cellar is unique and has specific cooling requirements. Heat load calculations should always be performed prior to selecting a cooling unit.

# FULLY DUCTED TWIN SPECIFICATIONS

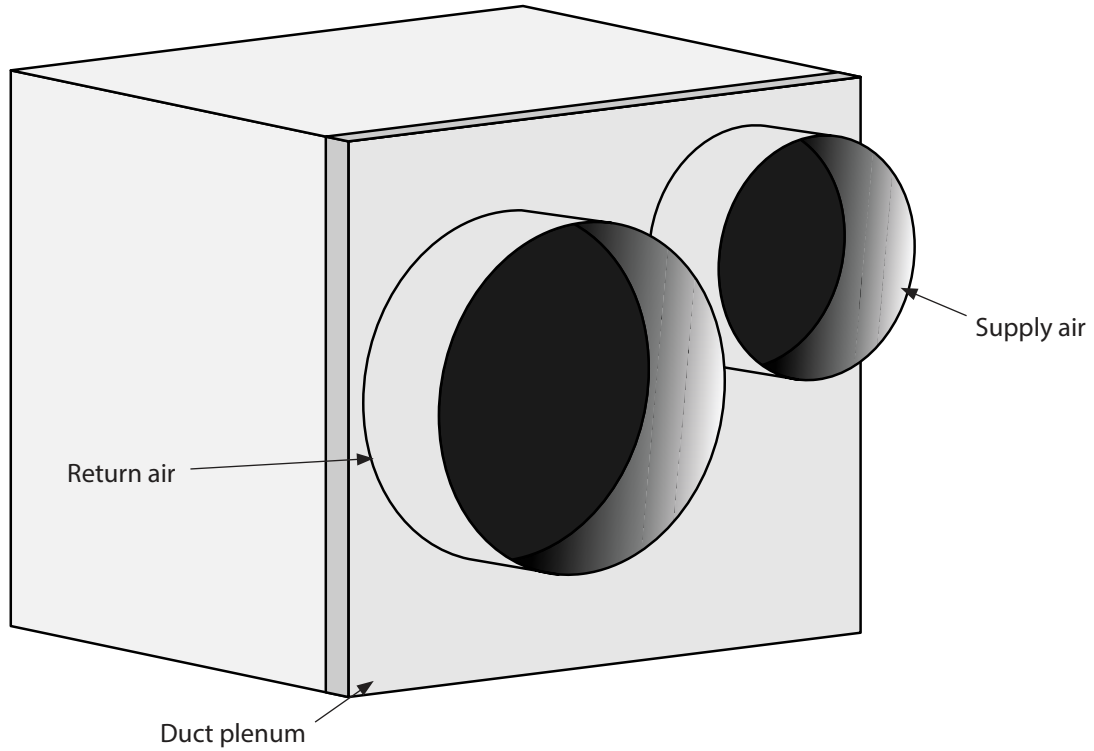

Model	9000 Master Evaporator (Fan Coil Unit)	9000 Slave Evaporator (Fan Coil Unit)
Cellar Size (cu. ft.)	Approx. 3000 cu. ft., provided cellar is fully insulated and sealed with proper vapor barrier*	
BTU/h w/85°F air entering condenser coil	Low: 6450/7366 • Medium: 7083/7657 • High: 7281/7879	
Dimensions	22.1"L x 22.5"W x 15.5"H	22.1"L x 22.5"W x 15.5"H
Refrigerant	R-134a	R-134a
Voltage Rating	115V (15-amp dedicated circuit required)	115V (15-amp dedicated circuit required)
Weight (lbs)	57	57
Amps	Evaporator: 1 running amp (per unit) Compressor: LRA 50, RLA 9.3	Evaporator: 1 running amp (per unit) Compressor: LRA 50, RLA 9.3
Line Set	Liquid line 3/8"; suction line 3/4" (less than 50 ft.), 7/8" (greater than 50 ft.)	
Duct Size	8" supply, 10" return (x2)	
Drain Line	1/2" ID clear plastic tubing (not included)	
Installation	Evaporator units can be installed up to 25 ducted feet away.	
Thermostat	Advanced digital display (connected to master unit) with 50-ft. cable; liquid-temperature-measuring bottle probe (also with 50-ft. cable)	
Temp. Delta	Can maintain a 55°F cellar temperature with up to 110°F condenser air intake temperature	
Warranty	Two-year limited warranty (parts and labor)	

\*Each cellar is unique and has specific cooling requirements. Heat load calculations should always be performed prior to selecting a cooling unit.

## CONDENSING UNIT SPECIFICATIONS

Model	9000 Condenser (Air-Cooled Condensing Unit)
Dimensions	24"L x 18.98"W x 16.16"H
Refrigerant	R-134a
HP	Ducted system: 3.1, non-ducted system: 3.34
Voltage Rating	230V (15-amp dedicated circuit required)
Weight (lbs)	75
Installation	Condensing unit can be installed up to 100 line feet from master evaporator unit.
Warranty	Two-year limited warranty (parts and labor)

## SPLIT SYSTEM CHECKLIST

In order to activate the warranty for this product, the information here must be complete and accurate. Any incorrect or omitted information will result in a return trip by the installing technician at their cost.

### DATA RECORDINGS

**NOTE: All readings need to be taken while the compressor is running.**

#### Line Set Information

- A. Line set length:
- B. Suction line OD:
- C. Liquid Line OD:

#### Bottle Probe

- A. Install probe in bottle of warm water to keep system operating.

#### Charging the System

- A. Fill system until bubbles dissipate from sight glass.  
**NOTE: Be careful not to overcharge the system.**

#### Temperature Differential at the Evaporator

- A. Measure return air and supply air temperatures at each evaporator to ensure adequate cooling of air in cellar.

#### Sub Cooling

- A. Measure head pressure at liquid line king valve. Convert pressure to temp using conversion chart.
- B. Temp of liquid line at king valve:
- C. Complete sub cooling calculation:  $A - B =$

#### Superheat Master

- A. Measure suction pressure at the suction line service valve, convert to temp.
- B. Measure the temperature of the suction line at the outlet of the evaporator.
- C. Complete superheat calculation:  $B - A =$   
**NOTE: There may be a need to adjust the TXV to get the correct superheat levels.**

#### Superheat Slave

- A. Measure suction pressure at the suction line service valve, convert to temp.
- B. Measure the temperature of the suction line at the outlet of the evaporator.
- C. Complete superheat calculation:  $B - A =$   
**NOTE: There may be a need to adjust the TXV to get the correct superheat levels.**

#### Compressor Temperature

- A. Measure temperature at bottom of compressor.  
**NOTE: Cool temp may indicate liquid in the compressor.**

#### Voltage and Amp Draw

- A. Measure voltage to compressor and amp draw.

#### Condensation Drain Test

- A. Pour water into each evaporator unit's drain pans to ensure they drain properly.

## 24V WIRING CONNECTIONS (EVAPORATOR UNITS)

1. Route a standard 18-5 thermostat wire from the slave unit installation location to the master evaporator unit.
2. Route a standard 18-5 thermostat wire from the master unit installation location to the thermostat installation location.
3. Locate the 18-5 thermostat wires inside of the master evaporator unit.
4. Connect all wires according to color: yellow to yellow, green to green, blue to blue, and red to red.
5. Locate the 18-5 thermostat wires inside of the slave evaporator unit.
6. Connect the wires according to color: yellow to yellow, green to green, and blue to blue.

### Thermostat Wiring Connections

1. At the thermostat terminal block, connect the wires according to color: yellow to Y, blue to C, green to G, and red to R.

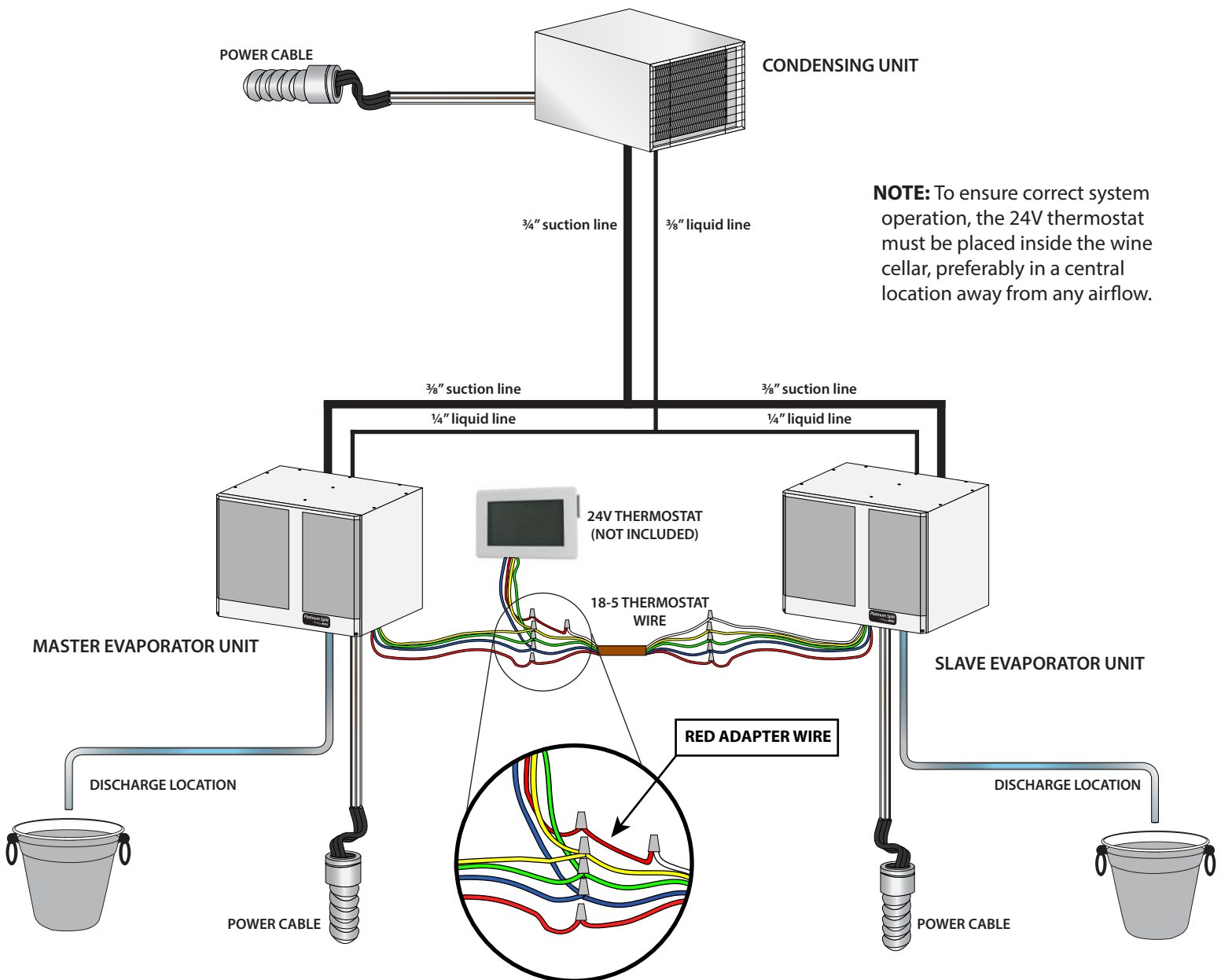

# PREPARING THE WALL-MOUNTED EVAPORATOR UNITS

## Required Tools:

- Drill
- $\frac{5}{32}$ " drill bit
- $\frac{1}{4}$ " socket drill bit
- $\frac{1}{4}$ " wrench
- Phillips-head screwdriver
- Tape measure
- Brazing torch
- Drywall saw
- Ladder
- Level
- Pliers
- Pencil

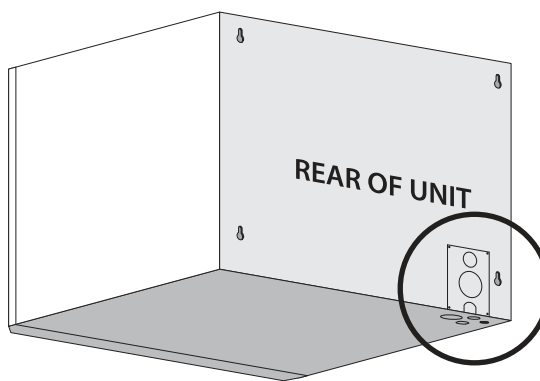
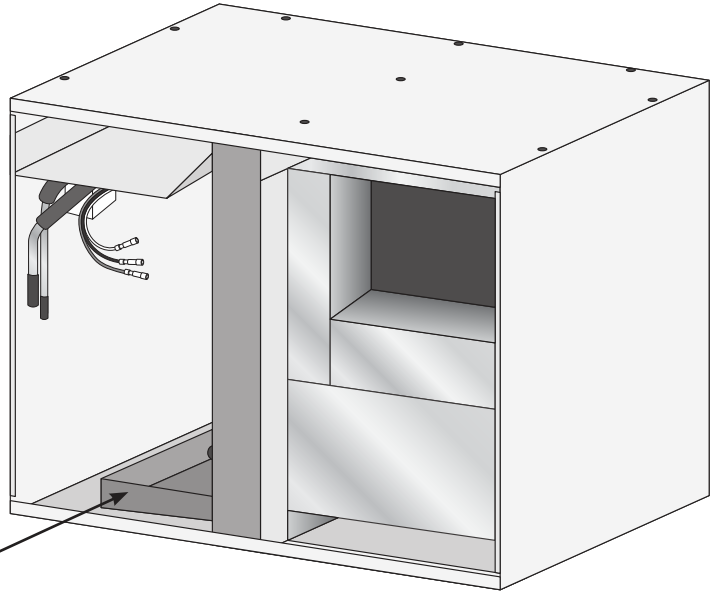

Drain pan

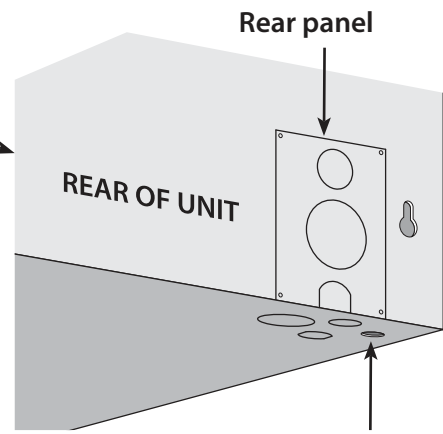

Rear panel

REAR OF UNIT

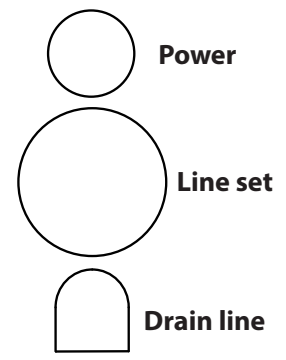

Thermostat wire routing for 24V thermostat  
(NOT INCLUDED)

1. Remove the rear panel and set aside.
2. For ease of installation, remove the nine (9) screws securing the top and remove the top.
3. Install strain relief around thermostat wires if routed through the circular connector hole in the bottom corner (see illustration).

## INSTALLING THE WALL-MOUNTED EVAPORATOR UNITS

Refer to the Wall-Mounted Evaporator Unit Installation Template for more information about mounting the wall-mounted evaporator units.

1. Locate two (2) wall studs in the desired mounting location spaced 16" on center.
2. Mark vertical lines on each stud 16" apart.
3. Mark an intersecting horizontal line at the desired height of the unit.
4. Make a mark on each stud 13½" down from the intersection of the horizontal and vertical lines.

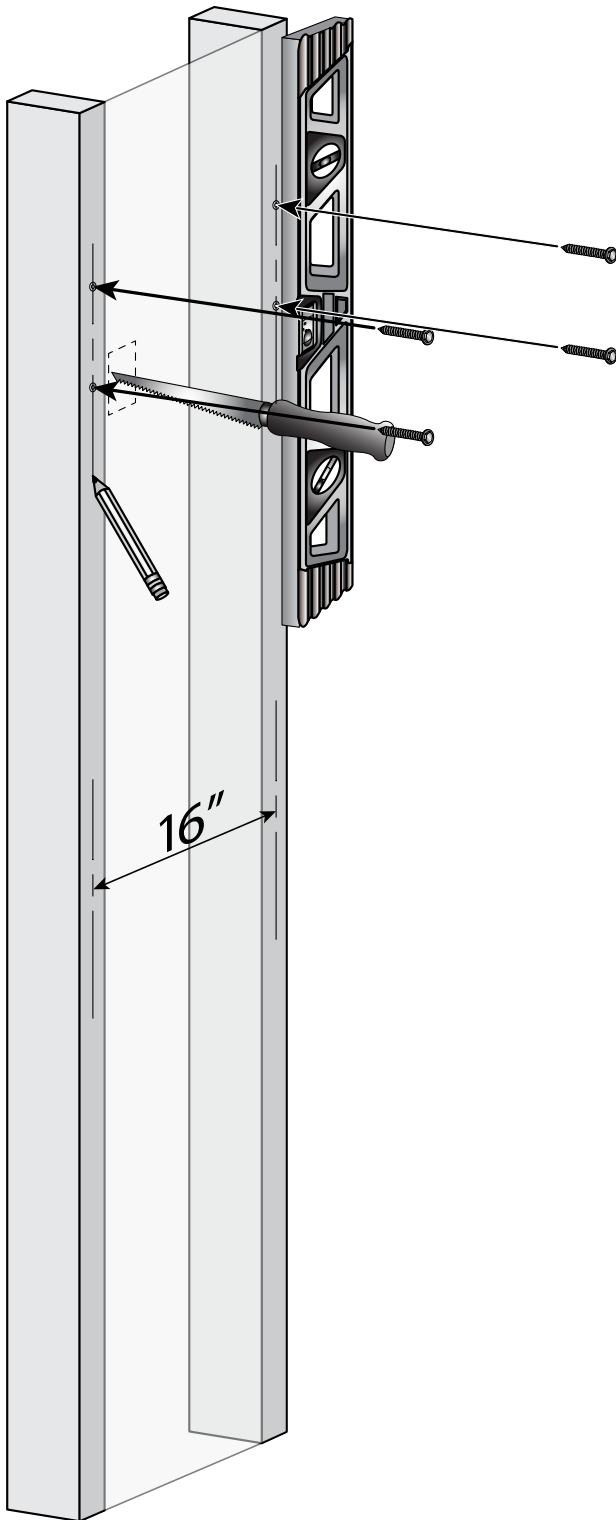

**NOTE:** The top of the unit must be installed a minimum of 6" and a maximum of 18" from the ceiling.

5. Install the four (4) supplied 1¾" hex-head screws into the studs at the locations marked leaving ⅛" between the wall surface and screw head.
6. If routing through a wall, cut out an access hole for the line set, drain line, display cable, and power wires.
7. Raise the evaporator to the installation location. Align the rear keyholes with the mounting screws and mount the unit.
8. Using a ¼" wrench or socket, tighten the top mounting screws.
9. Using ¼" and ⅜" copper tubing, route the liquid and suction lines through the knockouts in the housing. Be sure to extend the tubing far enough outside of the housing to extend through the wall if necessary.
10. Wrap both sides of the copper tubing with a wet rag to prevent overheating.
11. To prevent oxidation, purge the system with nitrogen.
12. Braze the copper tubing to the connections on the evaporator unit.

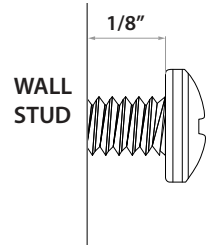

WRAP WITH WET RAGS

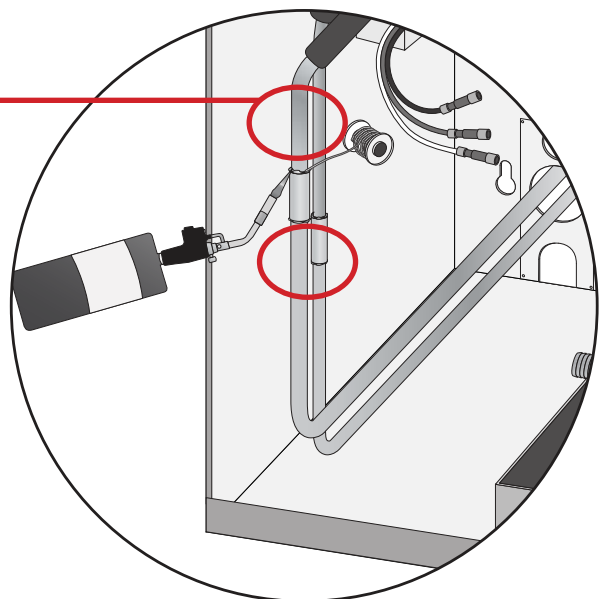



13. Insulate the suction line using Armaflex or similar insulation.
14. Using the cable ties and cable tie mounts provided, secure the drain line to the bottom of the housing to ensure a downward slope.
15. Route the power wires through the knockouts.
16. Connect the power wires according to color: connect the ground wire to the green wire, the hot wire to the black wire, and the neutral wire to the white wire.
17. Follow the instructions on page 12 for low-voltage wiring connections.

## PREPARING THE FULLY DUCTED EVAPORATOR UNITS

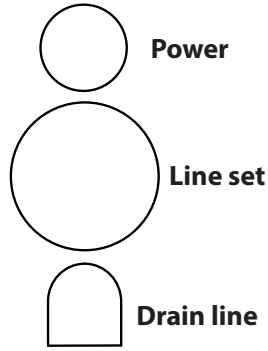
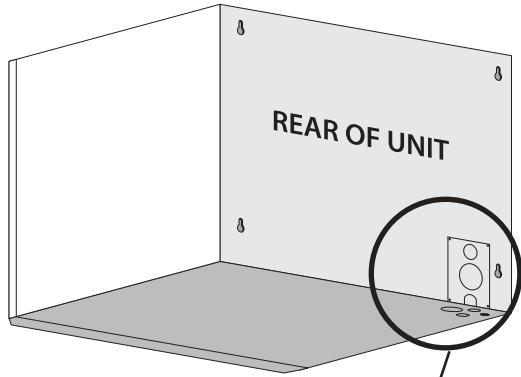

1. Remove the knockouts that you will be using to route the line set, power wires, and drain line.
2. Remove the insulation from the knockout holes.
3. For ease of installation, remove the nine (9) screws securing the top and remove the top.

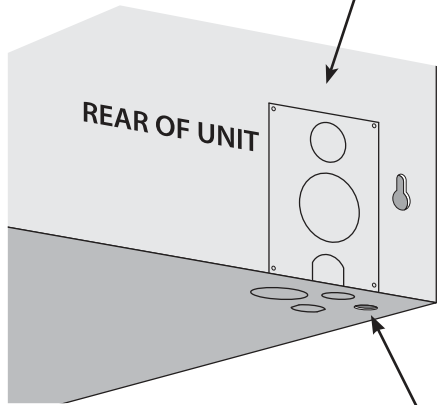

Thermostat wire routing for 24V thermostat  
(NOT INCLUDED)

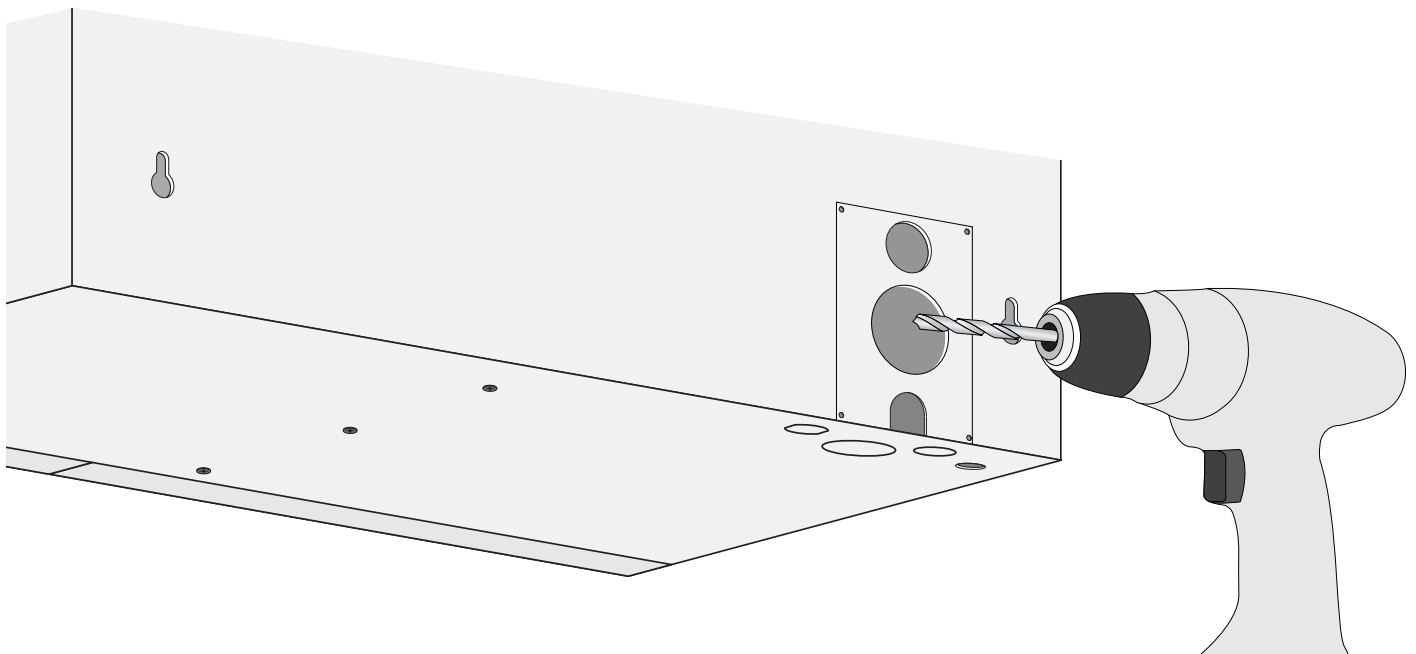

## INSTALLING THE FULLY DUCTED EVAPORATOR UNITS

1. Using ¼" and ⅜" copper tubing, route the liquid and suction lines through the knockouts in the housing. Be sure to extend the tubing far enough outside of the housing to extend through the wall if necessary.
2. Wrap both sides of the copper tubing to prevent overheating.
3. To prevent oxidation, purge the system with nitrogen.
4. Braze the copper tubing to the connections on the evaporator unit.
5. Insulate the suction line using Armaflex or similar insulation.
6. Using the cable ties and cable tie mounts provided, secure the drain line to the bottom of the housing to ensure a downward slope.
7. Route the power wires through the knockouts.
8. Connect the power wires according to color: connect the ground wire to the green wire, the hot wire to the black wire, and the neutral wire to the white wire.
9. Follow the instructions on page 12 for low-voltage wiring connections.

## DUCTING OVERVIEW

Use ductwork to connect the unit to the supply and return outlets in the wine cellar. Use only insulated ductwork to minimize cooling losses, prevent sweating, and reduce noise. Use ductwork on the condenser section to redirect or absorb sound, bring in outside air to the unit inlet, and/or exhaust the hot air.

**NOTE:** Do not exceed a total of 25 feet for each length of ductwork run and a combined total of 50 feet for both the supply and return lengths.

Avoid crimping the flexible ducts. This reduces airflow, causing the unit to operate improperly. Be sure all ductwork and outer surfaces in contact with the airflow are insulated and have a vapor barrier on the outside. Uninsulated supply and return ducts may cause bare, exposed metal surfaces to sweat, further degrading the insulation and equipment cooling capacity.



**Do not allow sharp turns to squeeze or decrease the inside diameter of the flexible ducting.**



### General duct recommendations:

- Provide support for the flexible duct to prevent sags and bends.
- Platinum Split Twin duct size: 8" supply and 10" return
- Stretch out the duct to make a smoother interior which reduces air resistance.
- Maximum duct length is 25 feet per evaporator unit.
- For 90° bends, use a 90° adjustable elbow.
- No more than two 90° bends on each duct. Sweep 90° bends are recommended rather than sharp 90° bends.

**NOTE:** For every 90° bend, the system loses 13 CFM of airflow.

**NOTE:** A 12" x 12" return air filter grille must be installed to prevent contaminants from entering the cooling system. Supply duct must be insulated so it does not sweat or pick up heat.

- Generously apply duct sealant to all metal seams to fill in gaps that can leak air. Allow sealant to dry until firm to the touch before applying fiberglass insulation.
- Do not squeeze or reduce the inside diameter of the ducts, as this will reduce airflow.
- Use short and straight ductwork where possible.
- Check that all fan blades move freely.
- Keep air paths free of loose foreign objects and debris.
- Locate the supply and return grilles inside the cellar to create an airflow pattern that maximizes air circulation in the room. Avoid short circulation of the air.
- If the unit is installed through the wall, it must be mounted no more than 18 inches from the wine cellar ceiling. If the unit is ducted, the cold air supply duct must be installed no more than 18 inches from the wine cellar ceiling.

### DO NOT:

- Install through-the-wall return air grilles at floor level where they will collect dust from the floor.
- Locate the supply or return air grille where it is blocked by bottles, boxes, or cases.

## DUCTING CONFIGURATIONS

There are several ways to duct this unit. Please review the different configurations to determine a basis for your particular installation. Remember to contact a wine cellar professional if you have any questions.

### Indoor Installation

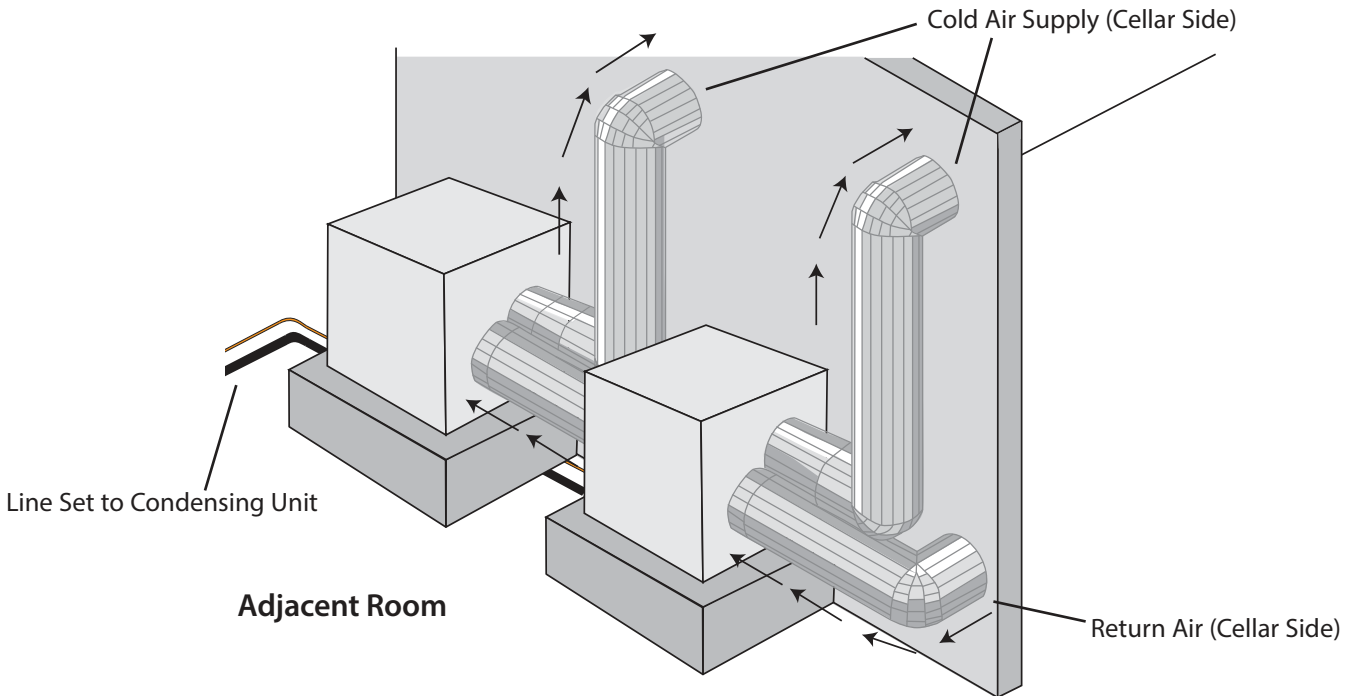

### Attic Installation

It is recommended that you use a condensate pan for this application.

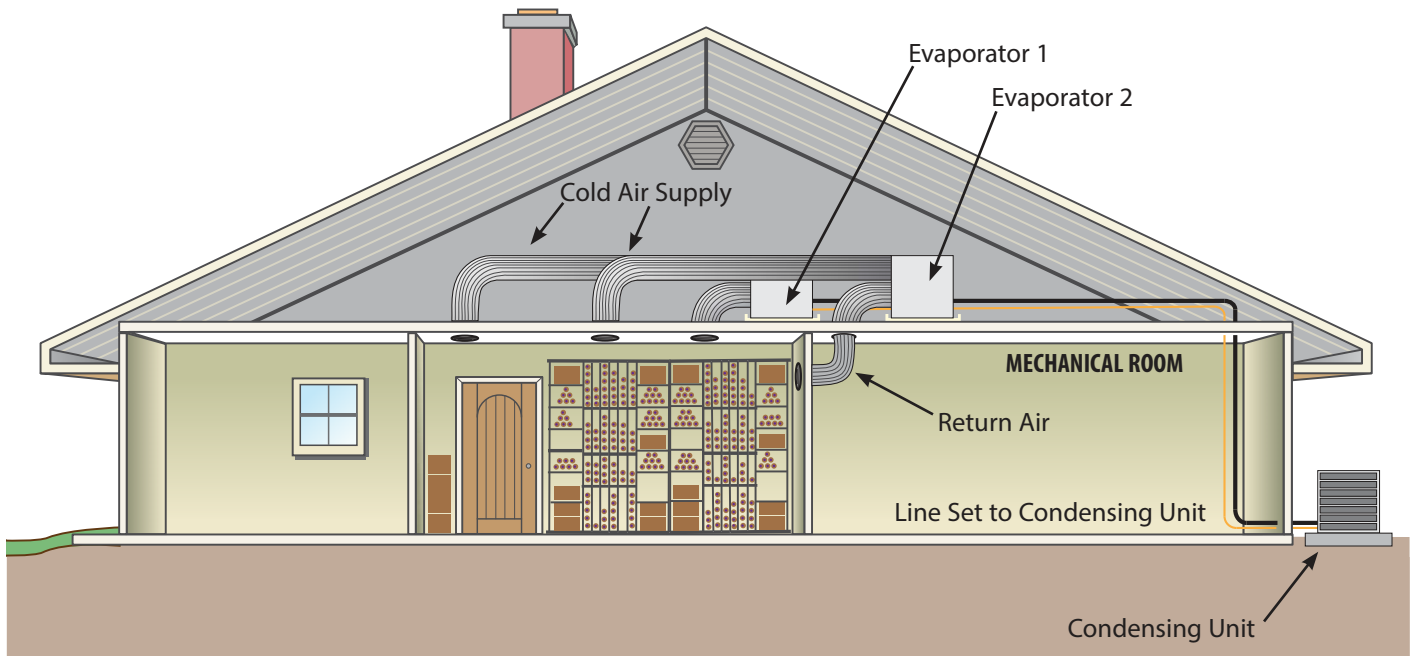

## DRAIN LINE

### Condensation Drain Line (not provided, but required)

The condensation drain line tube moves excess condensation from the evaporator units to a proper discharge location. It is important for the drain line tube to be properly connected in order to prevent leakage and other problems associated with excess condensation. (Each evaporator requires its own dedicated drain line.)

**Failure to use the condensation drain line tube will void the warranty on the unit.**

### Drain Line

Each evaporator unit comes with a drain line connection tee and two 90° fittings. Each unit is equipped with a ½" OD barbed fitting coming from the drip tray. (**NOTE:** ½" ID clear PVC tubing will need to be purchased and installed by the installing technician.) Installation of the drain line is mandatory, whether it leads through the wall and out of the cellar or remains inside the cellar. During operation, the cooling system will strip excess water from the air in order to maintain the proper level of humidity within the cellar. However, in extreme humidity, additional condensate will be removed; thus the drain line will prevent overflow and leakage by discharging the excess condensate.

### Routing the tubing out of the unit:

Cut a small piece of ½" tubing and connect one end to the drip tray port and the other to a 90° fitting. (This will direct the tubing toward the back of the unit where the tube will exit the unit.) Be sure to extend the tubing far enough outside the housing to extend through the wall if necessary.

**If routing out of the rear:** Cut a piece of tubing long enough to protrude out of the knockout on the back side of the unit.

**If routing out of the bottom:** Cut a piece of tubing long enough to reach the knockout in the bottom of the unit and install the supplied 90° fitting. (This will direct the tubing out of the bottom of the unit without the risk of kinking the tubing.) **DO NOT USE TEE WHEN ROUTING OUT OF THE BOTTOM.**

### Routing to discharge location if routed out of the bottom:

Connect the drain line directly to the second 90-degree barb fitting previously installed. Route the drain line to an appropriate drain location. No tee is required if draining through the bottom of the unit.



**WRONG:** Drain line is under water.

### Routing to discharge location if routed out of the rear:

Insert the middle barb of the barbed tee fitting into the end of the drain line coming from the evaporator. Rotate fitting so tee is in the orientation shown in the diagram below. Connect a 3-inch piece of ½" drain line to the barb on top. Connect the remaining "long" piece of drain tubing to the bottom barb of the tee. Route the drain line to an appropriate drain location.

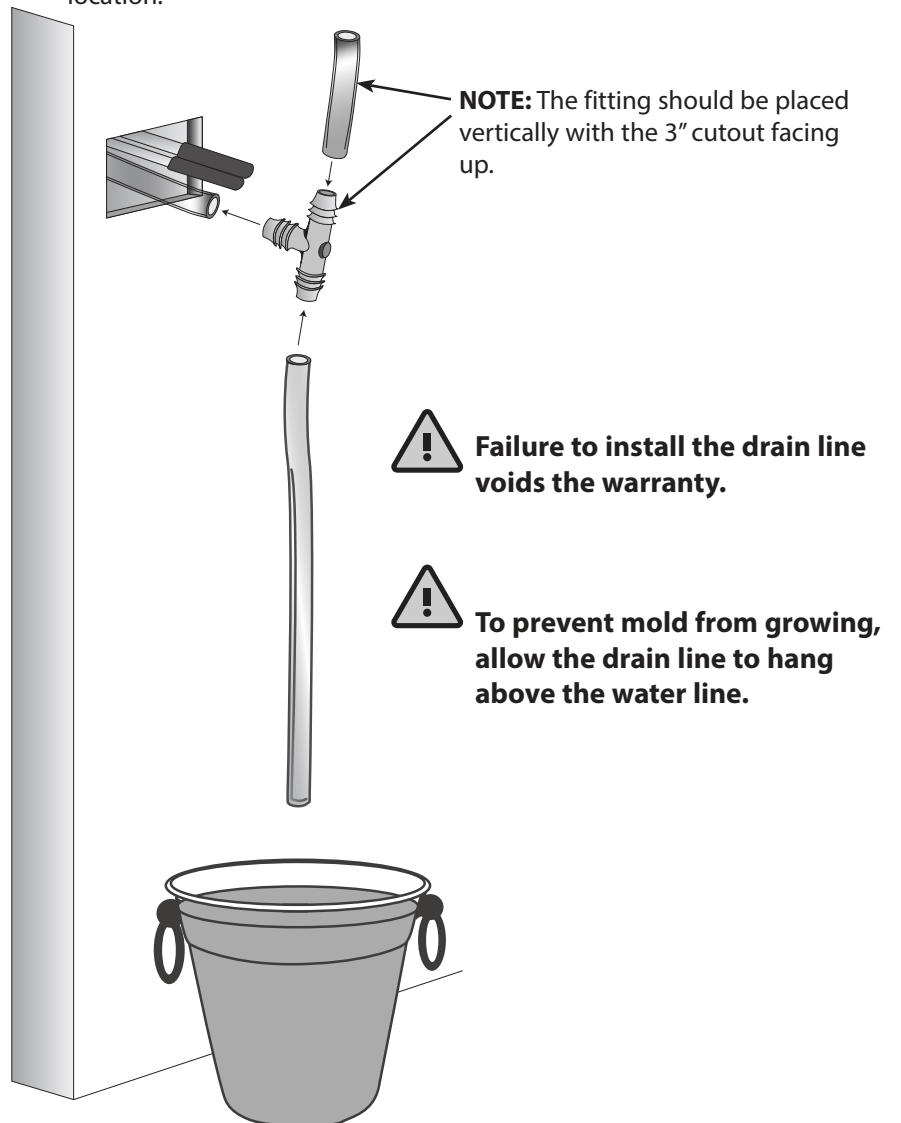

# PLATINUM SPLIT TWIN WITH 24V THERMOSTAT CONVERSION KIT WIRING DIAGRAM

PS-WM/FD TWIN 24V VERSION 5 WIRING DIAGRAM

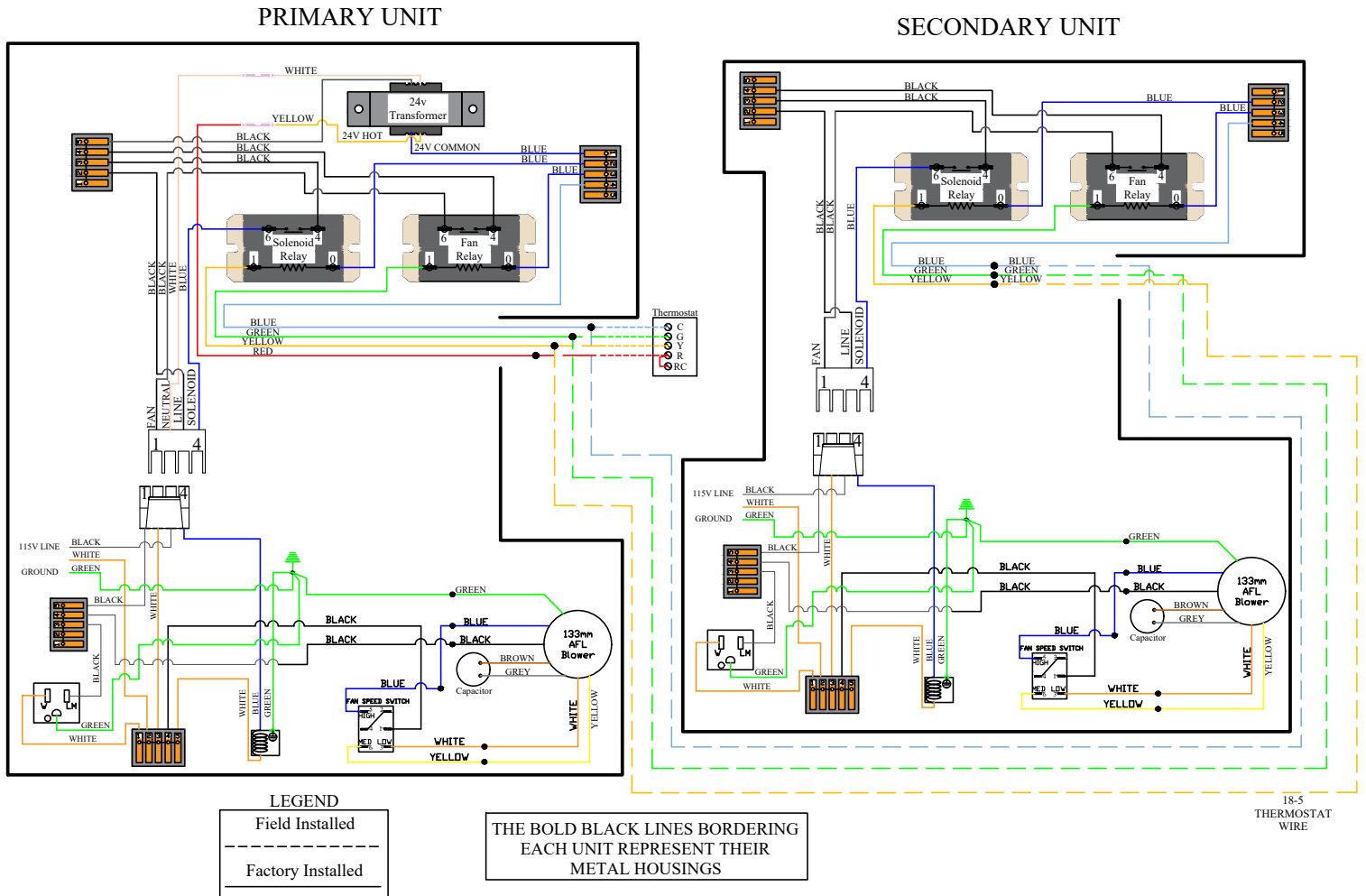

# PLATINUM SPLIT TWIN MASTER EVAPORATOR WITH 24V THERMOSTAT CONVERSION KIT WIRING DIAGRAM

## Platinum / WM/FD Version 5 24V

**LEGEND**

Field Installed	---
Factory Installed	---

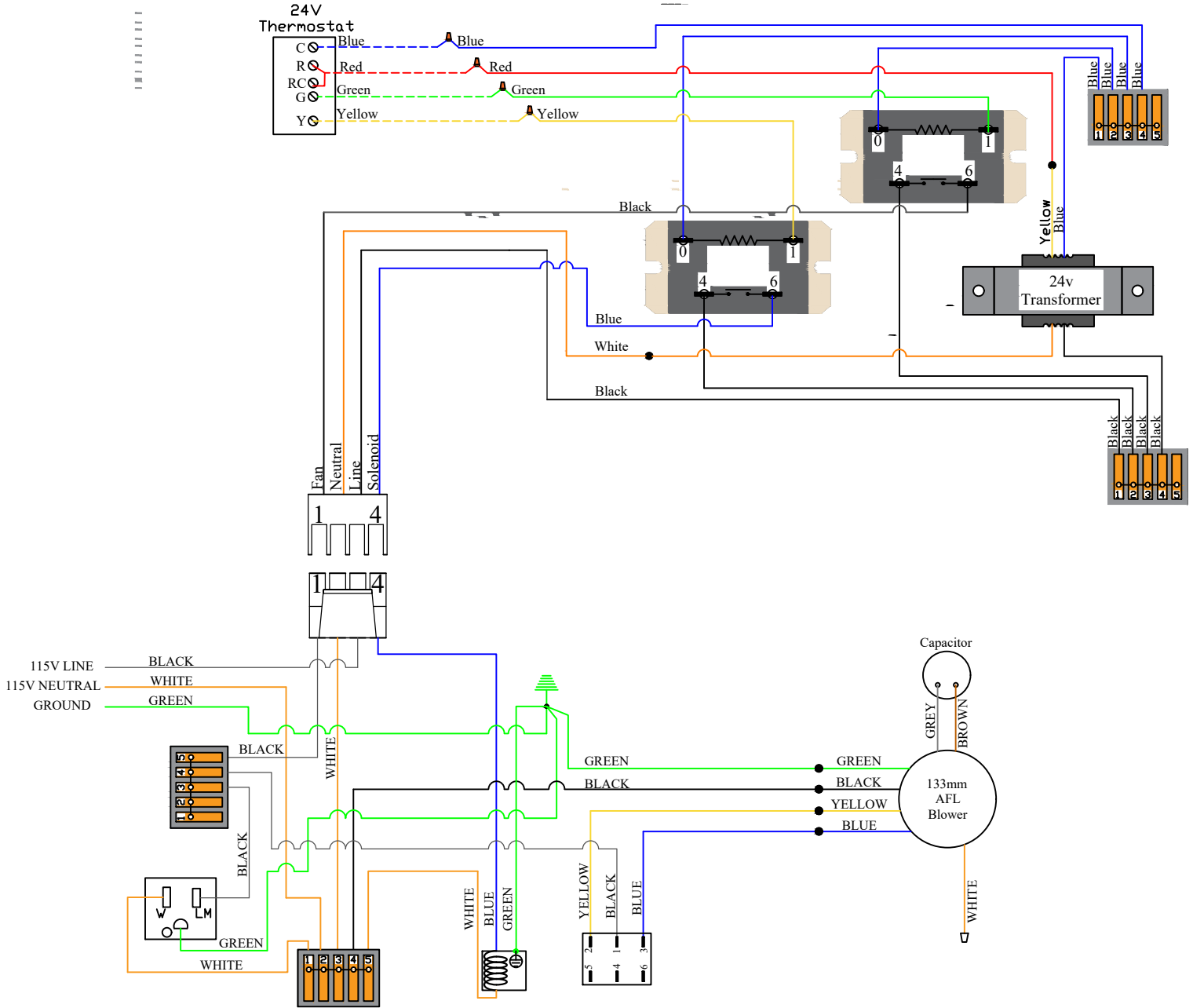



# PLATINUM SPLIT TWIN SLAVE EVAPORATOR WITH 24V THERMOSTAT CONVERSION KIT WIRING DIAGRAM

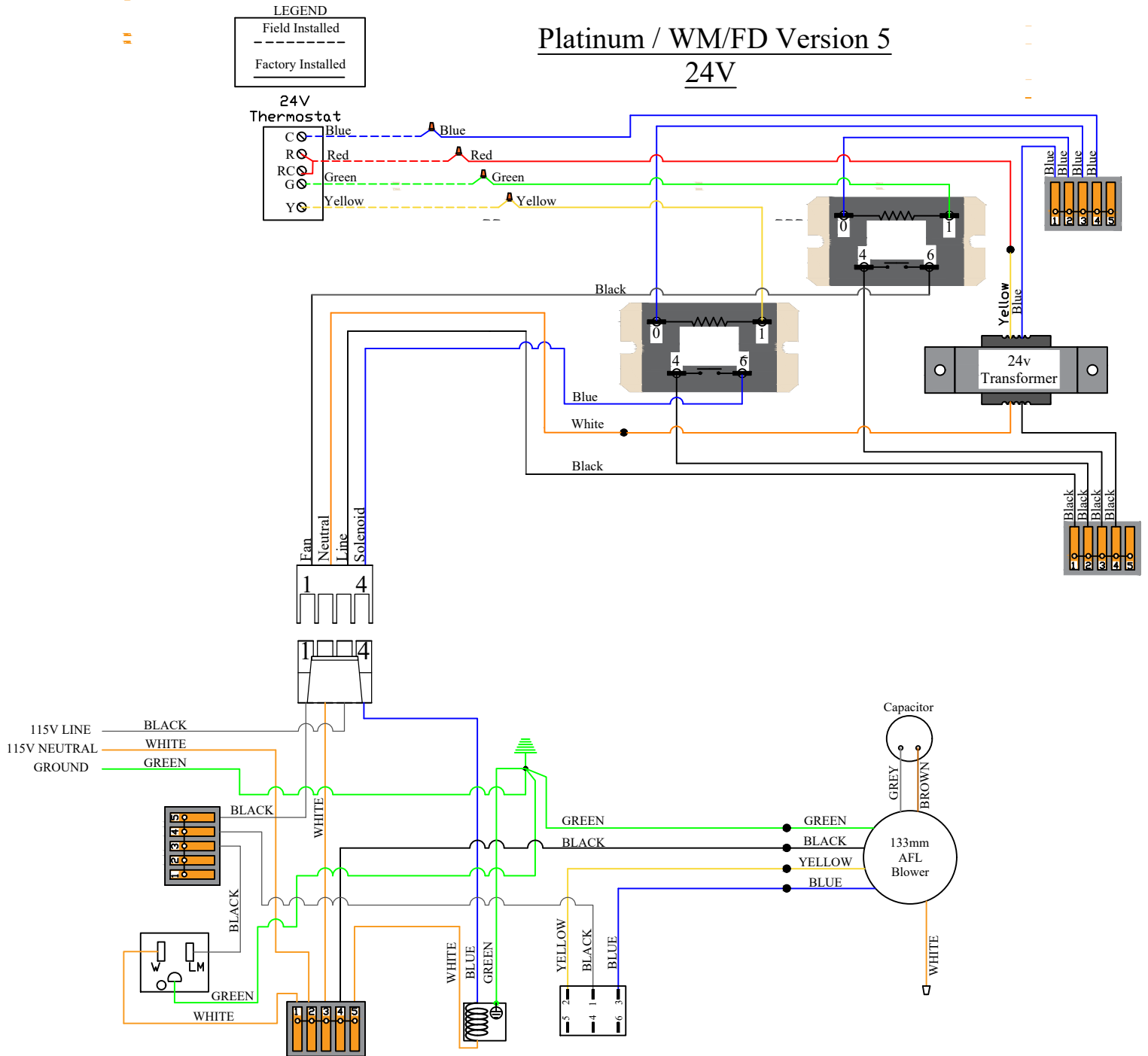

# PLATINUM SPLIT TWIN 9000 CONDENSING UNIT WIRING DIAGRAM

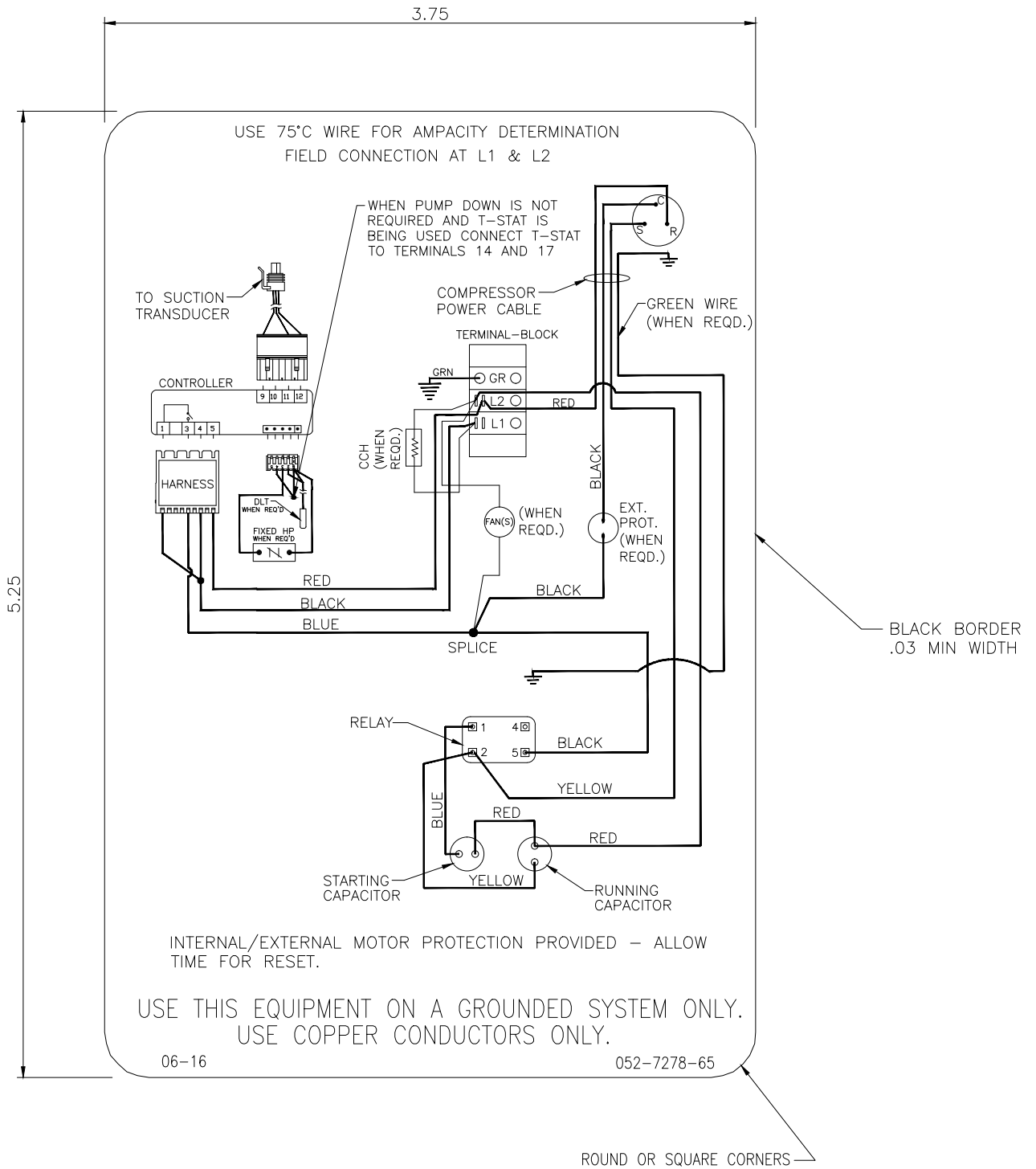

# COPELAND COLD WEATHER START KIT WIRING DIAGRAM

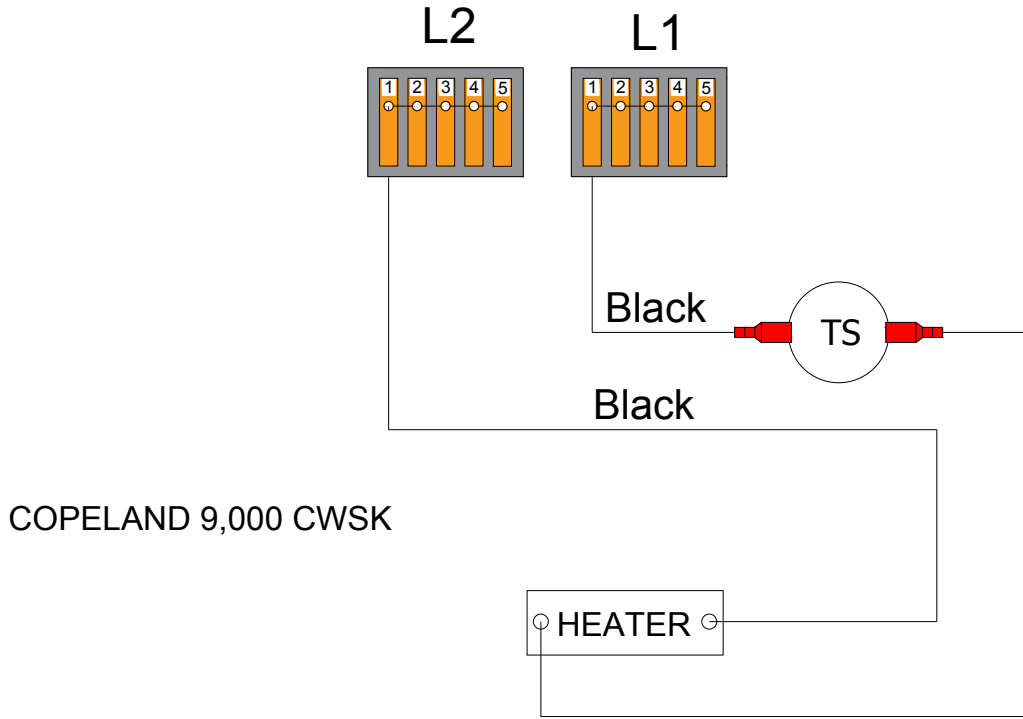

## PREPARING THE CONDENSING UNIT

### Electrical Needs

**The condensing unit requires a dedicated 230V single-phase 15-amp circuit.** The unit draws a large inrush current for about 1 second the instant the compressor starts. With a dedicated circuit and circuit breaker, the condensing unit will have sufficient power for effective operation. (The compressor is controlled by a low-pressure switch mounted on the condensing unit. This feature eliminates the need for wiring between the evaporator units and the condensing unit.)

- Ensure the voltage supplied matches the rating specified on the unit spec label.
- Provide a dedicated circuit and circuit breaker for the condensing unit.
- Provide a weatherproof disconnect for the condensing unit if it is located outside.

Power surges and spikes can damage sensitive electrical equipment. WhisperKOOL recommends plugging the unit into a surge protector or power conditioner in order to protect your system. As outlined in our terms and conditions, power surges and spikes are not covered under warranty.

**DO NOT USE A GROUND FAULT INTERRUPTER (GFI) WITH THIS PRODUCT.**

In case the system should lose power, check the home/main circuit breaker. If the system does not respond properly, refer to the Troubleshooting Guide on page 38.

## INSTALLING THE CONDENSING UNIT

The condensing unit can be installed inside a well-ventilated area of the home, but it is typically installed outside. Exterior applications will require the use of a protective housing, and the amount of sun exposure should be considered when selecting the placement of the condensing unit. **Make sure there is a minimum of three (3) feet of horizontal clearance in every direction around the unit (five feet is ideal).** Check that proper power is supplied.

Set the condensing unit level and with proper clearances in accordance with the instructions. As designated on the name plate, make sure that the proper electric disconnect and fuse protection have been installed. Ensure that the unit is connected but not turned on and is ready for refrigerant piping connections.

### Indoor condensing unit installation:

Inside installations require special consideration, as there must be adequate ventilation to remove the heat created during normal operations. An exhaust port with fan may need to be installed to ensure that heat is effectively removed from the utility room. The cellar will need a return grille or some other provision for 800-1000 CFM of cool air to enter the room to replace the exhausted air. Unobstructed airflow to and from the unit is a critical factor in the unit's overall performance. **Make sure there is a minimum of three (3) feet of horizontal clearance in every direction around the unit (five feet is ideal).** This will assure that the unit can move the air around the room in an efficient manner.

### Outdoor condensing unit installations:

You must utilize the exterior condensing unit housing for outdoor installations. Place the condensing unit on a solid foundation in a location with adequate ventilation. **Make sure there is a minimum of three (3) feet of horizontal clearance in every direction around the unit (five feet is ideal).** The unit should be elevated 18" in order to avoid any possible flooding or damage by animals, and should be clear of leaves, dirt, and other debris.

# LINE SET PIPING DIAGRAMS

It is required to size the suction line tubing according to this chart.

Platinum Split Twin	Line Set Length	<25ft	26-50ft			50-100ft			
	Vertical Rise	15ft	<3ft	3-10ft	>10ft	<3ft	3-10ft	>10ft	
	Suction Line Sizing	3/4"					7/8"		
	Liquid Line Sizing	3/8"				3/8"			

## Condensing Unit Installed Below Fan Coil

### Option 1

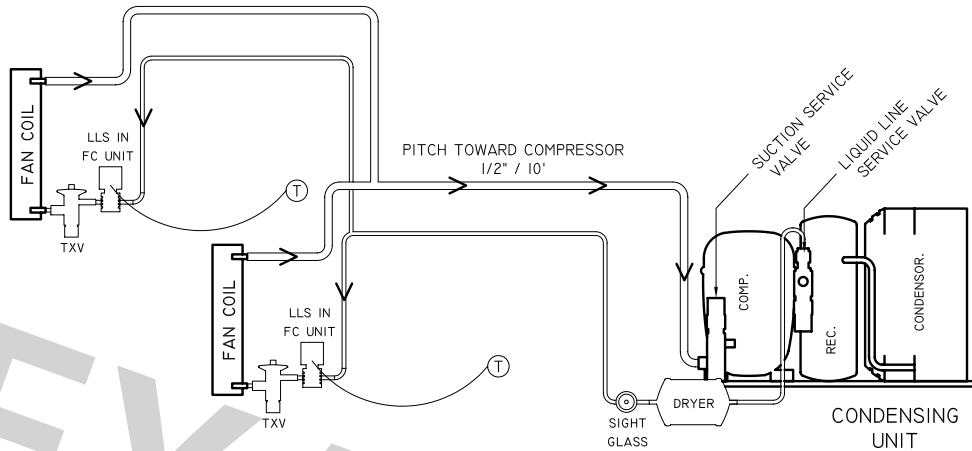

SINGLE FAN COIL PIPING SYSTEM  
 RECOMMENDED REFRIGERANT PIPING DESIGN FOR CONVENTIONAL FACTORY SUPPLIED FAN COIL  
 AND AIR COOLED CONDENSING UNIT COMPONENTS. REFRIGERANT LINE LENGTHS IN EXCESS  
 OF 90' NOT RECOMMENDED.

THIS DRAWING APPLIES TO CONDENSING UNIT LOCATION AT OR BELOW THE ELEVATION OF  
 THE FAN COIL UNIT. SUCTION PIPE TO BE INSULATED WITH 1/2" WALL INSULATION  
 (ARMAFLEX BRAND) OR EQUAL.

## Condensing Unit Installed More Than 3' Above Fan Coil

### Option 2

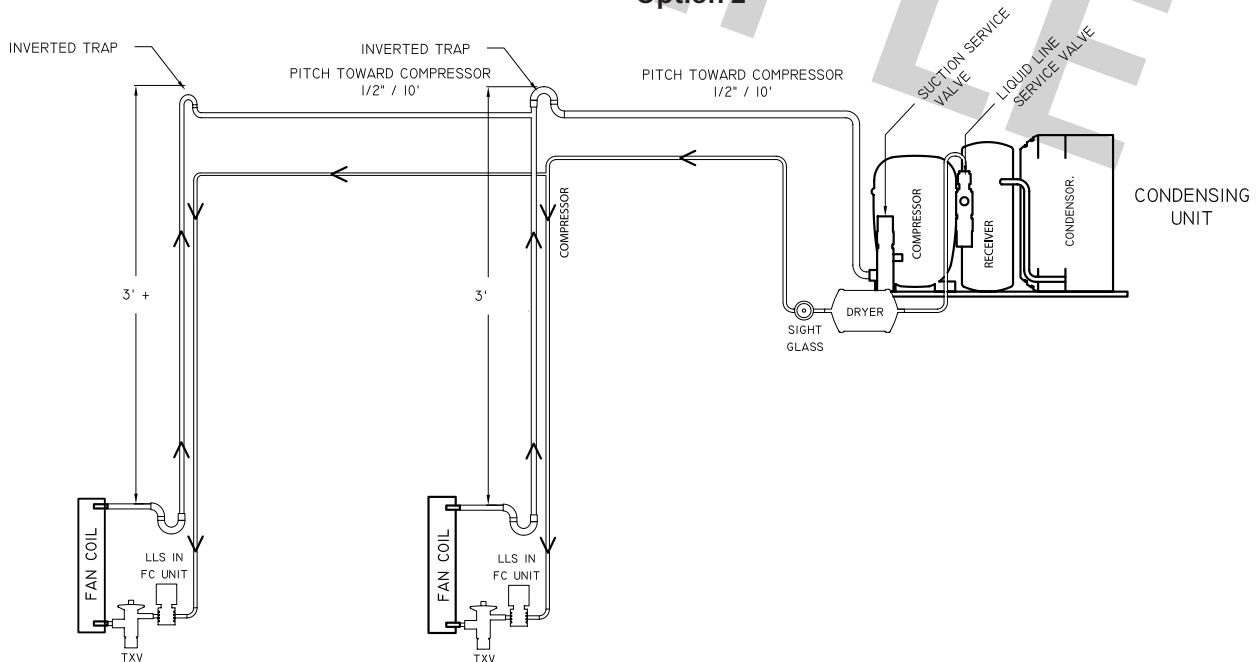

## INSTALLING THE CONDENSING UNIT

**DO NOT BLOCK** airflow through the exterior housing. This will restrict airflow and void the warranty.

### Refrigerant Piping Overview

- Using the charts and illustrations found above, route the line set between the evaporator units and the condensing unit. Be sure to reference the chart for correct line set sizing. All horizontal suction piping should be pitched toward the condensing unit half an inch for every 10 feet of pipe. When installing and routing the line set, cap both ends of each tube to prevent debris from entering the tubing.
- Prior to connecting the piping to the evaporator and condensing units, loosely connect a refrigerant manifold to the suction and liquid line service valves.
  - Purge the hoses with dry nitrogen and tighten the hose connections.
  - Remove the service valve caps and turn the valve stem clockwise half a turn to unseat the valve and open the service port. Keep the piping ports sealed until ready to braze.
- Purge the fittings with dry nitrogen at a slow rate to prevent formation of highly abrasive copper oxide.
- Perform all brazes.
- Pressure-test the system and check for leaks.
- Insulate the suction line using wall cellular insulation or equivalent. Seal all seams with Armaflex 520 foam insulation adhesive or equivalent. Wrap each seam using line set tape.

### Liquid Line Piping Procedure

- Braze a short piece of copper tubing to the liquid line service valve.
- Connect the supplied refrigerant drier to the tubing.
- Downstream from the drier, connect the moisture-indicating sight glass in an easily visible location.
- Run the tubing to the evaporator units and attach to the liquid line connection on the evaporator units.

### Suction Piping Procedure

- Install an access valve at the outlet of the evaporator units.
- Connect an appropriately sized suction line to the suction line service valve on the condensing unit.
- Run the pre-insulated suction line to the evaporator units and attach to the suction line connection on the evaporator units.

### Brazing Procedure

- Connect the bottle probe to the master evaporator unit.
- Fill a wine bottle 75% full of room-temperature water. Insert the bottle probe into the neck of the bottle as far as possible. It is important that the bottle probe stopper be compressed by the neck of the bottle to ensure water will not leak.
- Energize the master evaporator unit and set the controller to call for cooling.
- Verify that the setpoint on the control is set low enough to allow the unit to run for the entire length of the brazing, evacuation, and charging procedure.
- Remove the valve depressors from the gauge hoses on a four-valve manifold.
- Connect the manifold to the low-pressure service valve port on the condensing unit and a nitrogen tank.
- Open the suction line service valve and purge the system with nitrogen.
- Braze all connections and cool off quickly.
- Cap the access valve on the suction line.
- Connect the high-pressure hose from the manifold to the liquid line service valve port.
- Pressure test the system at 250 psig for 30 minutes.
- Check all braze joints with leak detector or soap bubbles.
- Release the nitrogen once it is confirmed that there are no leaks.

## INSTALLING THE CONDENSING UNIT (continued)

### Evacuation

- Remove the nitrogen tank from the manifold and attach the manifold to the refrigerant tank.
- Install a micron gauge on the access valve near each evaporator unit.
- Mid-seat both service valves.
- Install service caps on the valves.
- Energize the liquid line solenoid valve.
- After confirming that there is fresh oil in the vacuum pump, connect the  $\frac{3}{8}$ " hose from the manifold to the pump.
- Start the pump and run it until the micron gauge on each evaporator unit reads 200 microns or less.
- Disconnect the vacuum pump from the system.
- Break the vacuum with R-134a refrigerant.
- Remove the micron gauge from the access valve.

### Charging

- Install a low-pressure gauge on the access valve near each evaporator unit.
- With the power off to the condensing unit, admit liquid refrigerant through the liquid line service valve until the refrigerant stops flowing.
- Turn on the circuit breaker for the condensing unit. The compressor should turn on if the pressure in the suction line is above 25 psig.
- Add refrigerant through the suction line service valve by throttling in small amounts of liquid refrigerant in two-second intervals. (Refrigerant must be throttled in or the compressor may be damaged.) Observe the sight glass. If bubbles are present, add more refrigerant until the sight glass is clear.
- Once the sight glass is clear, check the superheat at the suction line service valve. Adjust the TXV until the total superheat is between 20-30°F.
- Under normal operation, with the wine cellar at 55°F and the ambient temperature at 85°F, the low side pressure should be between 28-32 psig and the high side should be between 160-180 psig.

### Finalizing the Installation

- Confirm that the entire suction line from the TXV to the suction line service valve is insulated using cellular insulation or equivalent. Seal all seams with Armaflex 520 foam insulation adhesive or equivalent.
- Confirm that the control is displaying the correct temperature.

## INSTALLING THE WALL MOUNT KIT

1. If removed, reinstall the top panel of the unit housing.
2. Align the front grille with the four (4) ball studs on the housing. Push the front grille onto the ball studs until it snaps into place.
3. Using a Phillips-head screwdriver, fasten the bottom two (2) screws to fasten the grille to the unit.

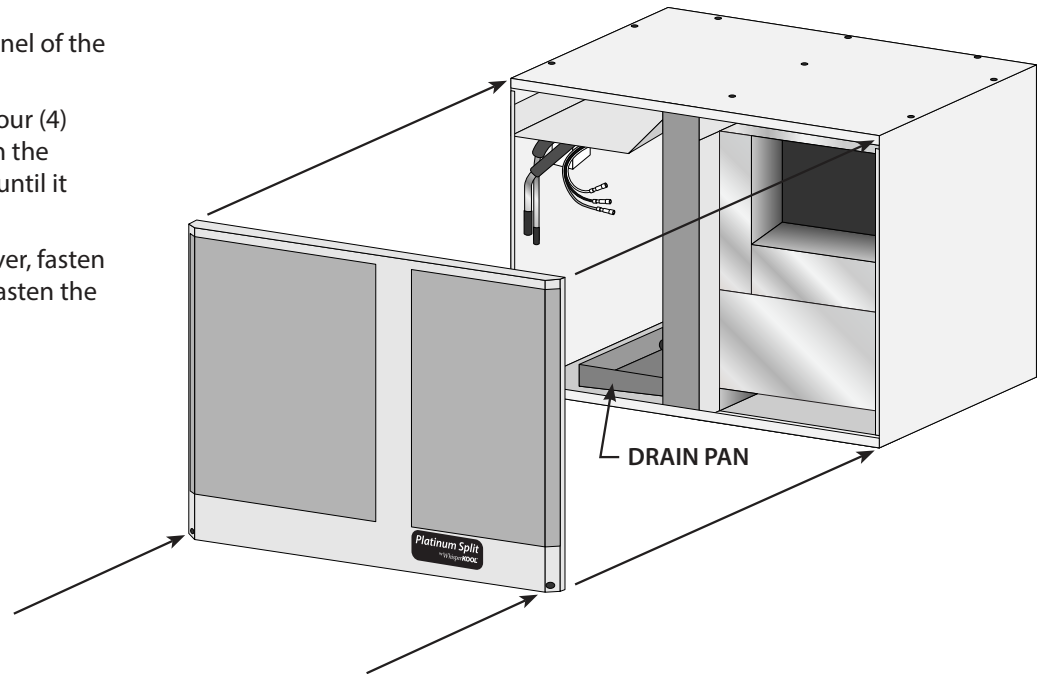

## INSTALLING THE DUCTED PLENUM

1. If removed, reinstall the top panel of the unit housing.
2. Align duct plenum with the four (4) ball studs on the housing. Push the duct plenum onto the ball studs until it snaps into place.
3. Using a Phillips-head screwdriver, fasten the bottom two (2) screws to fasten the plenum to the unit.
4. Connect the supply and return duct work to the unit.
5. Using duct tape or foil tape, seal the seam between the plenum and unit.
6. Insulate all exposed metal on the unit to prevent surface condensation.

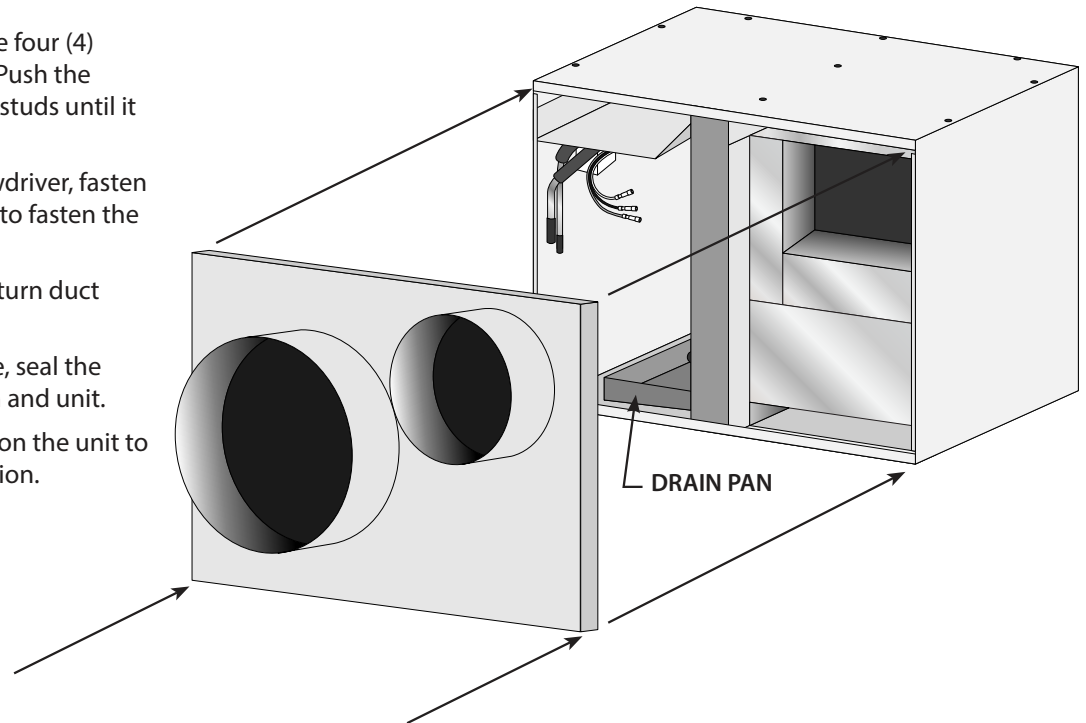

**NOTE:** Max ducting length is 25 feet per evaporator unit.



# COPELAND WIRING PROCEDURE

**Copeland Wiring Procedure** Step # 1



Use a 1/4" nut driver to remove the screws securing the cover to the compressor electrical compartment.

**Copeland Wiring Procedure** Step # 2



Remove the cover as shown.

### Copeland Wiring Procedure

Step # 3



### Copeland Wiring Procedure

Step # 4

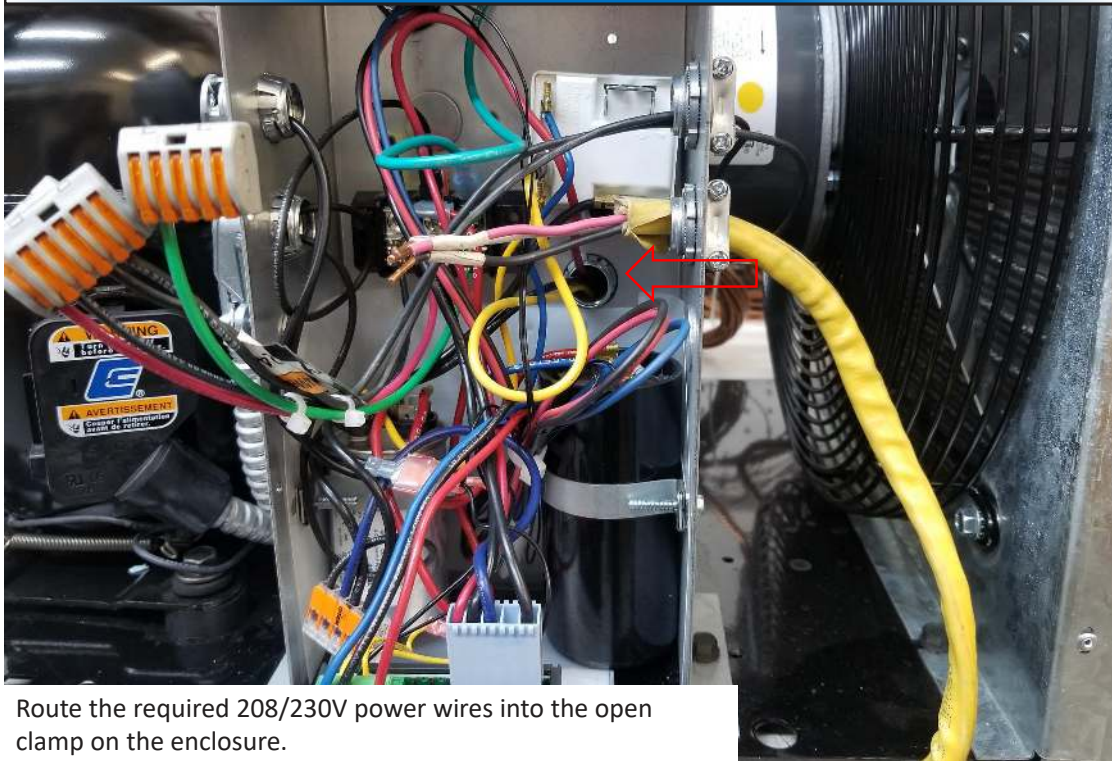



### Copeland Wiring Procedure

Step # 5

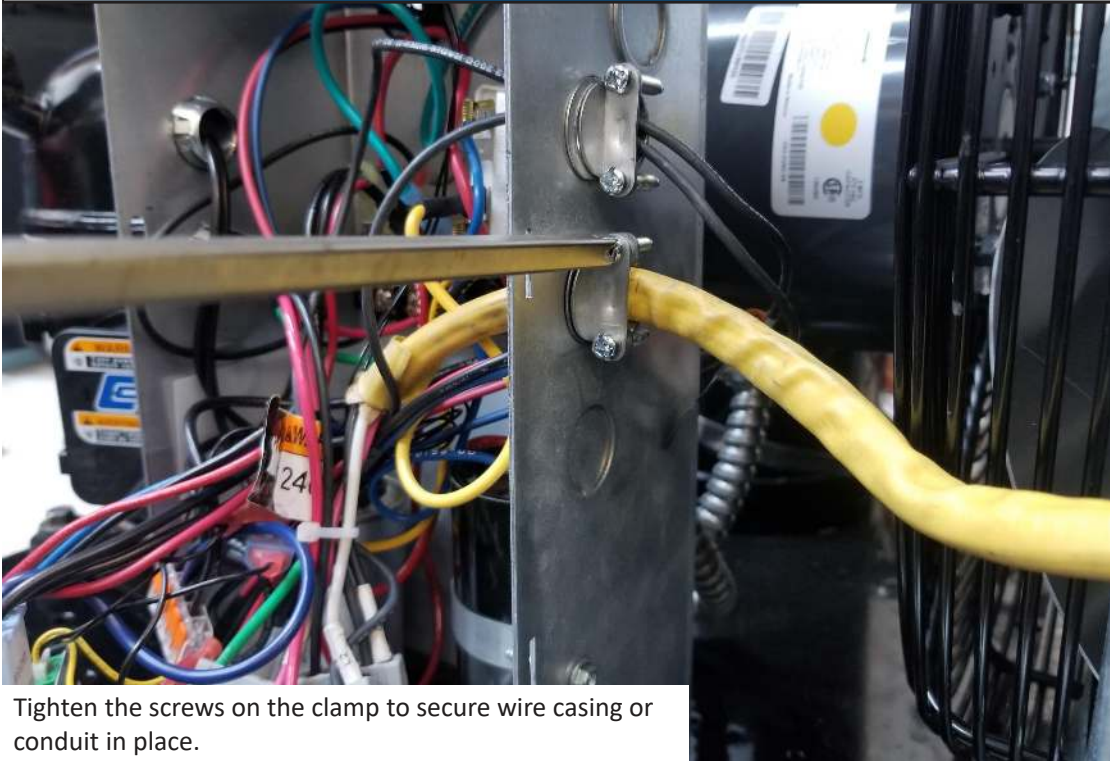

Tighten the screws on the clamp to secure wire casing or conduit in place.

### Copeland Wiring Procedure

Step # 6

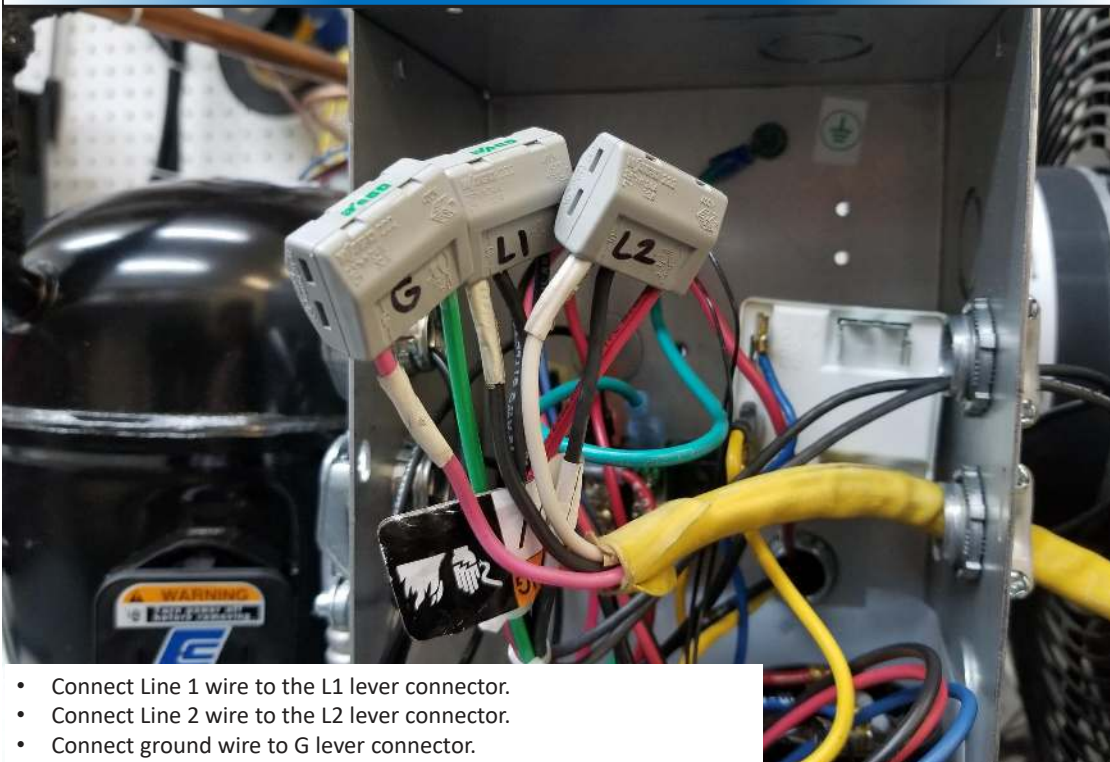

- Connect Line 1 wire to the L1 lever connector.
- Connect Line 2 wire to the L2 lever connector.
- Connect ground wire to G lever connector.

### Copeland Wiring Procedure

Step # 7



Push wires back into enclosure and place the controller panel back in place..

### Copeland Wiring Procedure

Step # 8



Re-install cover.

## SYSTEM OPERATION

*The cooling system is equipped with the hardware needed to support a 24-volt air conditioning thermostat (not included).*

### Initial Start-Up

Set the thermostat to COOL and fan switch to AUTO. Lower the setpoint to the desired cellar temperature. (A temperature of 55°F is the recommended setpoint.) See thermostat instructions for details.

### Normal System Cycle

The thermostat should turn the cooling system on when it senses a temperature one (1) degree higher than the setpoint. See thermostat instructions for details.

### Anti-Short Cycle

Most thermostats have a safety feature that will prevent the condensing unit from cycling on and off within a short period of time. During the anti-short cycle, the condensing unit will typically remain off for 5-7 minutes. See thermostat instructions for details.

### Fan Operation

If the fan switch on the thermostat is in the AUTO position, it will run only during the cooling cycle. If the fan switch on the thermostat is in the ON position, the fan will continuously run until the switch is set back to the AUTO position.

### Operation in Low Ambient Temperatures

The condensing unit comes equipped with a LAC (Low Ambient Control). The LAC is a three-way modulating valve that responds to discharge pressure. When the discharge pressure falls below the valve's dome pressure, the valve modulates open to the discharge port which allows discharge gas to bypass the condenser. Mixing the discharge gas with the liquid creates high pressure at the condenser outlet, reducing the flow and causing liquid to backup in the condenser. Flooding the condenser reduces the area available for condensing. This reduction in condenser surface area results in a rise in condensing pressure during cold ambient conditions.

The condensing unit controller is preset at the factory. The cut-in pressure is preset to 25psi and the cut-out pressure at 15psi. During low ambient temperatures (40°F or below), it will be necessary to adjust the cut-in pressure to 10-15psi (15psi is preferred) and the cut-out to 5psi to ensure compressor startup. See page 36 for instructions on adjusting the cut-in and cut-out pressures of the condensing unit.

**NOTE:** To ensure correct system operation, the 24V thermostat must be placed inside the wine cellar, preferably in a central location away from any airflow.



# Emerson<sup>™</sup> Electronic Unit Controller

## Quick setup and troubleshooting guide

### Adjusting Low Pressure Settings

- Hold DOWN and SET simultaneously for 3 seconds to enter menu (PSI light will flash) ▼ + SET
- Cycle through menu options – UP/DOWN ▲ ▼
- Select function – SET SET
- Adjust value – UP/DOWN ▲ ▼
- Store function - SET SET
- Exit menu - UP and SET ▲ + SET



Low Pressure Cut-In



Low Pressure Cut-Out

### Accessing Alarm Code Information

- Press and release ALARM [ALARM]
- Cycle through menu options – UP/DOWN ▲ ▼
- Press SET to see number of alarms SET
- Press SET again to return to menu options SET
- Exit menu - UP and SET ▲ + SET

Alarm	Description
PoF	Keypad locked
Pon	Keypad unlocked
P1	Suction probe failure
P2	Condenser probe failure
P3	DLT probe failure
HA	High condenser temperature alarm
dLt	DLT temperature alarm
dLL	DLT lock alarm
HP	High pressure trip alarm
HPL	High pressure trip lock-out alarm
EE	Module Failure
LOC	Number of lock-outs

Note: After 15 seconds of inactivity the controller will revert to the default display.

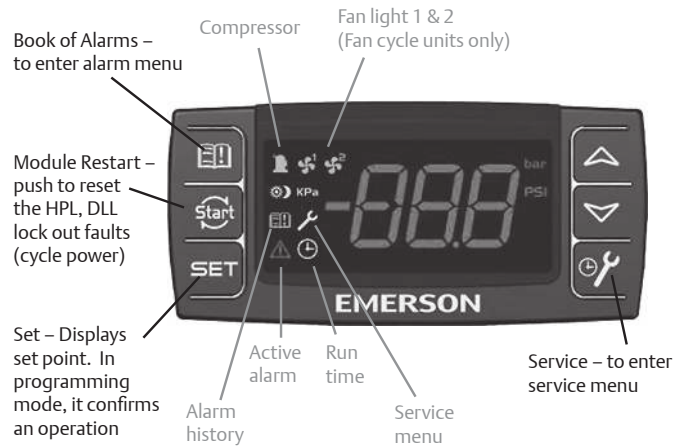

When light is on, feature or component is on or active

### Accessing Service Menu

- Hold SERVICE for 3 seconds [SERVICE]
- Cycle through menu options – UP/DOWN ▲ ▼
- Press SET to see number of alarms SET
- Press SET again to return to menu options SET
- Exit menu - UP and SET ▲ + SET

Code	Description
StH	CompressorStarts –1000 -999999
StL	Compressor Starts –0 -999
CHH	CompressorHours -1000 -999999
CHL	Compressor Hours -0 -999
F1H	Fan 1 Hours -1000 -999999
F1L	Fan 1 Hours-0 -999
F2H	Fan 2 Hours -1000 -999999
F2L	Fand 2 Hours -0 -999

Example: If StH=12 and StL=500, the total number of compressor starts=12,500

For more information visit [EmersonClimate.com/ElectronicUnitController](http://EmersonClimate.com/ElectronicUnitController) or call 1-888-367-9950



Display	Likely Causes	Other Possible Causes
Controller display remains blank after applying power	<ul style="list-style-type: none"> <li>Unit power not properly applied - check for proper applied voltage</li> <li>Power cable harness not plugged in properly or securely into the back of the controller – check connections</li> </ul>	<ul style="list-style-type: none"> <li>Power cable miswired – inspect cable, replace if needed</li> <li>Electrical assembly miswired – trace wiring diagrams</li> </ul>
Controller displays correctly, but the green compressor light is off and the compressor is not running	<ul style="list-style-type: none"> <li>Jumper cable not plugged in properly or securely into the back of the controller – check connections</li> <li>Controller is currently above the cut-in setting – check cut-in and cut-out settings</li> </ul>	<ul style="list-style-type: none"> <li>Jumper cable miswired – inspect cable, replace if needed</li> </ul>
Controller displays correctly and the green compressor light is on and the compressor is not running	<ul style="list-style-type: none"> <li>Power cable harness not plugged in properly or securely into the back of the controller – check connections</li> </ul>	<ul style="list-style-type: none"> <li>Power cable not wired to the contactor or compressor correctly, check wiring</li> <li>Power cable miswired – inspect cable, replace if needed</li> </ul>
Controller flashes “135” or “P1”	<ul style="list-style-type: none"> <li>Current system pressure is above 135 PSIG – wait for system to pull down</li> <li>Green harness not plugged in properly or securely into the back of the controller – check connections</li> <li>Cable not connected properly with the pressure transducer – check connections</li> </ul>	<ul style="list-style-type: none"> <li>Transducer cable miswired – inspect cable, replace if needed</li> <li>Damaged transducer – inspect transducer, replace if needed</li> </ul>
Controller flashes “P2” on a unit with fan cycling	<ul style="list-style-type: none"> <li>Green harness not plugged in properly or securely into the back of the controller – check connections</li> </ul>	<ul style="list-style-type: none"> <li>Transducer cable miswired – inspect cable, replace if needed</li> <li>Check condenser temperature sensor resistance values against table in AE-1376, Section 8</li> </ul>
Controller flashes “P2” on a unit without fan cycling after replacing a controller	<ul style="list-style-type: none"> <li>Controller not programmed properly – check parameters in the advanced menu</li> </ul>	
Controller flashes “P3” on a unit with DLT	<ul style="list-style-type: none"> <li>Jumper cable not plugged in properly or securely into the back of the controller – check connections</li> </ul>	<ul style="list-style-type: none"> <li>Jumper cable miswired – inspect cable, replace if needed</li> <li>Faulty DLT temperature sensor – check the discharge line temperature sensor resistance values against table in AE-1376, Section 8</li> </ul>
Controller flashes “P3” on a unit without DLT after replacing a controller	<ul style="list-style-type: none"> <li>Controller not programmed properly – check parameters in the advanced menu</li> </ul>	
Fans not running on a fan cycling unit and the fan lights are not on	<ul style="list-style-type: none"> <li>Condensing temperature is currently below the fan cut-in</li> <li>Condensing temperature sensor not properly installed – check installation</li> </ul>	<ul style="list-style-type: none"> <li>Transducer cable miswired – inspect cable, replace if needed</li> <li>Faulty temperature sensor - check condenser temperature sensor resistance values against table in AE-1376, Section 8</li> </ul>
Fans not running on a fan cycling unit and the fan lights are on	<ul style="list-style-type: none"> <li>Power cable harness not plugged in properly or securely into the back of the controller – check connections</li> </ul>	<ul style="list-style-type: none"> <li>Power cable miswired – inspect cable, replace if needed</li> <li>Electrical assembly miswired – trace wiring diagrams</li> </ul>
Controller flashes “HP” at power-up	<ul style="list-style-type: none"> <li>Jumper cable not plugged in properly or securely into the back of the controller – check connections</li> <li>High pressure switch is seeing above the cut-out pressure</li> <li>For a replacing an -00 controller, ensure that the jumper cable is the latest revision. It should have a blue wire in the harness. See replacement instructions for more details</li> </ul>	<ul style="list-style-type: none"> <li>Jumper cable miswired – inspect cable, replace if needed</li> <li>Faulty fixed Hp switch – inspect switch, replace if needed</li> </ul>
Controller flashes “HP” or “HPL”	<ul style="list-style-type: none"> <li>System operation causing high discharge pressures, check system operations</li> </ul>	<ul style="list-style-type: none"> <li>Bad high pressure switch, verify system pressure when the pressure switch trips.</li> <li>See AE-1376, Section 7.2 for more details</li> </ul>
Controller flashes “DLT” or “DLL”	<ul style="list-style-type: none"> <li>System operation causing high discharge line temperatures, check system operations</li> </ul>	<ul style="list-style-type: none"> <li>Faulty temperature sensor - check DLT sensor values against table in section 8</li> <li>See AE-1376, Section 7.1 for more details</li> </ul>
Controller flashing “HPL” or “DLL”	<ul style="list-style-type: none"> <li>System operation causing high discharge pressures (HPL) or high discharge line temperatures (DLL) repeatedly, check system operations</li> <li>To clear an “HPL” or “DLL” lockout, you can hold the Restart button for 3 seconds twice, or cycle power to the unit. If using the reset button, the alarm condition will have to clear (DLT temperature drops or Hp switch resets), and any minimum off time will need to complete (5 minutes for the fixed Hp switch)</li> </ul>	

## EmersonClimate.com/ElectronicUnitController

2013ECT-46 (9/13) Emerson is a trademark of Emerson Electric Co. ©2013 Emerson Climate Technologies, Inc. All rights reserved.

EMERSON. CONSIDER IT SOLVED.™

**WHISPERKOOL TROUBLESHOOTING GUIDE****Ice forming on the evaporator units**

Possible cause	Solution
Evaporator filters or coils are dirty	Remove the filters and wash them, then clean the coils with a vacuum. If coils are very dirty, use a spray bottle with a small amount of liquid dish detergent or coil cleaner. Spray coils, let set for five minutes, then flush with fresh water.
There is something blocking the supply and/or return air	Remove blockage
The evaporator fans are not turning on	Call customer service for details on how to perform the bypass plug test. If all components run correctly, and the system cools during the bypass plug test, there is either an issue with the 24V thermostat conversion kit or the thermostat. Contact customer service for further action.
If evaporator units continue to ice	Observe ice formation pattern. If only part way up the coil face, the system could be low on refrigerant. If all the way up, the coils may be dirty or airflow is blocked.
The setpoint is too low	Raise setpoint to recommended temperature of 55°F.

**Unit does not run/power up**

Possible cause	Solution
Evaporator units are not plugged in	Make sure the units are plugged into an outlet
Power switch not on	Turn unit on by pressing the power button on the control
Line voltage rating is incorrect for the system	Check line voltage to make sure there is 110V-120V
Thermostat not calling for cooling	Adjust thermostat to a lower temperature
Faulty thermostat or wiring	Contact WhisperKool customer service

**Cellar temperature is too warm**

Possible cause	Solution
The temperature of the room to which the condensing unit exhausts exceeds 110°F	Intake temperature needs to drop below 110°F
The system is undersized for the cellar	Order correctly sized system
There is something blocking the supply and/or return air on the evaporator units or the condensing unit	Remove airflow obstruction(s)
Evaporator units are mounted too low in the cellar	Relocate units so the distance from the ceiling and top of the units is no more than 18"
One or more of the fans is not turning on	Please contact the installing technician to troubleshoot
Compressor is not turning on	Please contact the installing technician to troubleshoot
Compressor keeps cycling on overload	Make sure all fans are working and there is no airflow obstruction
Poor seal around door or other areas requiring a seal (around the unit, wall joints, etc.)	Make sure there are no air gaps around the door. If door seal is damaged, replace it.
Thermostat set too high	Adjust thermostat to a lower temperature
Evaporator coils are frosted or iced up	Observe ice formation pattern. If only part way up the coil face, evaporator units could be low on refrigerant. If so, contact your installing technician to assist with troubleshooting.

**System runs constantly**

Possible cause	Solution
Leaky door seal or poorly insulated cellar	Fix leaky door seal and insulate cellar



<b>Units leak water</b>	
<b>Possible cause</b>	<b>Solution</b>
Evaporator units are not level	Evaporator units should be level on the wall to prevent leaking
Drain lines clogged or kinked	Check drain lines to make sure water can flow freely
Drains are clogged, preventing water from escaping	Disconnect drains and clear them out; check drains for blockage
Drain lines do not have a downward slope	Fix drain lines so there is a downward slope from the units to the drains
Coils are iced, causing drain pans to freeze and water to overflow	Melt ice with blow drier. Soak up with a towel.
<b>System runs but does not cool</b>	
<b>Possible cause</b>	<b>Solution</b>
Lack of air flow	Make sure fans are unobstructed and that the evaporator filters, evaporator coils, and condenser coils are clean and free of debris
System undersized	Contact WhisperKool customer service
Compressor is overheating	Shut system off for 1 hour to allow compressor to cool. Turn back on and check for cooler air flow out. If compressor runs, check for and clean condenser coil as possible cause of compressor overheating. If problem repeats, contact you installing technician to assist with troubleshooting.
<b>Evaporator fan runs but compressor does not</b>	
<b>Possible cause</b>	<b>Solution</b>
Compressor and/or starting components faulty	Please contact the installing technician to troubleshoot
Compressor may have overheated	Shut system off for 1 hour to allow compressor to cool. Turn back on and check for cooler air flow out. If compressor runs, check for and clean condenser coil as possible cause of compressor overheating. If problem repeats, contact your installing technician to assist with troubleshooting.
Thermostat not sending power to Y terminal	Call customer service for details on how to perform bypass plug test
24V thermostat conversion kit solenoid relay not working correctly	Call customer service for details on how to perform bypass plug test
<b>Compressor runs but evaporator fan does not</b>	
<b>Possible cause</b>	<b>Solution</b>
Faulty fan motor	Please contact the installing technician to troubleshoot
Faulty thermostat	Please contact the installing technician to troubleshoot
<b>Compressor short cycles</b>	
<b>Possible cause</b>	<b>Solution</b>
Master evaporator unit's thermostat location	Move thermostat out of airflow
System low on refrigerant charge	Please contact the installing technician to troubleshoot
Condensing fan motor/capacitor faulty	Please contact the installing technician to troubleshoot
Compressor and /or starting components faulty	Please contact the installing technician to troubleshoot
<b>Humidity in cellar too low</b>	
<b>Possible cause</b>	<b>Solution</b>
Not enough moisture	Purchase and place a humidifier (or a decorative fountain) in cellar

Units equipped with the 24V Thermostat Conversion Kit:

<b>System does not power up/run</b>	
<b>Possible cause</b>	<b>Solution</b>
Batteries on thermostat have lost their charge	Change batteries
Thermostat wired incorrectly	Check wiring on 24V thermostat and correct
Wiring issue at master evaporator unit	Contact Customer Service for troubleshooting
24V transformer in master evaporator unit has failed	Contact Customer Service for troubleshooting
<b>Evaporator fans run continuously</b>	
<b>Possible cause</b>	<b>Solution</b>
Fan switch on thermostat set to "on"	Set fan switch to the "auto" position
Fan relay in thermostat or 24V conversion kit stuck on	Call Customer Service for details on how to perform the bypass plug test

## MAINTENANCE SCHEDULE

<b>Monthly</b>	<ol style="list-style-type: none"><li>1. Check coils</li><li>2. Check for unusual noise or vibration</li><li>3. Check the drain lines to see if they are above the waterline (if draining into a vessel)</li></ol>
<b>Quarterly</b>	<ol style="list-style-type: none"><li>1. Use a vacuum with brush attachment to clean coils; be careful not to crush coil fins when cleaning</li><li>2. Change duct filters if the system is ducted</li></ol>
<b>Annually</b>	<ol style="list-style-type: none"><li>1. Inspect for corrosion</li><li>2. Check wiring connections and integrity of cords</li><li>3. Pour a 50/50 bleach solution into the drain lines every spring</li></ol>



## Care and Cleaning of Air Cooled Condensing Units

### Introduction

Proper care is essential to assure good life of condensing units. Dirty or damaged condensers will reduce the efficiency and capacity of the system.

Care must be taken in choosing solutions to be used for cleaning condensers and condensate pans. Chlorinated cleaners and anti-bacterial cleaning agents can be damaging and should be avoided. Caustic and acidic cleaners should be avoided as well. Failure to do so may accelerate component corrosion and ultimately lead to component failure.

### Condenser Coils

There are many commercially available condenser coil cleaners on the market. Coil cleaners should be designed to remove build-up on fins and coils. Coils should be thoroughly rinsed of the cleaners once cleaning has been completed. Follow the manufactures instruction for proper usage. Preventive maintenance and routine cleaning of coils is important to assure good life.

When cleaning the coil, an absorbent type material should be placed under the area to be cleaned in order to capture most of the cleaning compound, thus minimizing any type of chemical attack.

### Condensate Pans

Condensing units with condensate pans and condensate tubes are designed to evaporate condensate water only. Other ingredients introduced into the condensate pan can accelerate pan and/or tube corrosion. As foreign agents are introduced into the condensate pan, condensate water will be evaporated leaving the foreign agent behind. This can lead to a high concentration of the agent and possible corrosion of the tubing and/or base.

Coil cleaning agents must not be allowed to drain into the condensate pan as this may cause damage. Upon completing the coil cleaning, be certain that all residue is removed from the condensate pan.

Only non corrosive cleaners should be used to assure good life of the condensing unit components. No hydrocarbon based cleaners should be used to clean the unit. Bleach solutions must be avoided due to its high corrosive nature.

Under no circumstances should cleaning agent ingredients contain any of the solutions listed below:

### Unacceptable solutions are:

- Chlorinated Solvents**
- Bleaches**
- Vinegar**
- Ammonia**
- Anti-Bacterials**
- Salts**

### Preventative Maintenance

Maintenance should be performed at regular intervals. Coils should be cleaned at least monthly, possibly more depending on the environment. Condensing units with condensate pans should also be checked and cleaned regularly to prevent damaging build up in the pan.

### Safety

Please follow all safety recommendations listed by the manufacturer of the cleaning agent(s), these would include proper clothing, gloves and eye protection.

## BYPASS TEST PROCEDURE

**NOTE:** If instructed by a WhisperKOOL representative, follow the directions below to test the cooling unit using the bypass plug provided in the accessory kit.

1. Disconnect power from the evaporator units.
2. Loosen the two (2) screws on the front of the grille or duct plenum.
3. Pull the grille or duct plenum away from the evaporator units.
4. Remove the screw securing the control panel in place.
5. Slide the control panel down, out of the evaporator housing. The control panel has two (2) hooks which allow it to attach to the evaporator units for easy serviceability.
6. Disconnect the Molex connector labeled #4.
7. Locate the bypass plug included in the accessory kit.
8. Plug the bypass plug into the male Molex connector.
9. Connect power to the evaporator units. The system should immediately turn on. If all the components are not operational, disconnect power immediately and contact customer service. If all components seem to be operating correctly, allow the system to run for four (4) hours. Monitor the temperature of the cellar to determine if the system is cooling properly.
10. Once the test is complete, remove the bypass plug. Plug the Molex connector back in to the system's wiring.
11. Replace the control and faceplate.

## TECHNICAL ASSISTANCE

WhisperKOOL Customer Service is available Monday through Friday from 6:00 a.m. to 4:00 p.m. Pacific Standard Time.

The appointed customer service representative will be able to assist you with your questions and warranty information more effectively if you provide them with the following:

- The model and serial number of your WhisperKOOL system(s).
- Location of unit and installation details, such as ventilation, ducting, construction of your wine cellar, and room size.
- Photos of the cellar and installation location may be needed.

### Contact WhisperKOOL Customer Service

1738 E. Alpine Ave  
Stockton, CA, 95205  
[www.whisperkool.com](http://www.whisperkool.com)

**Email:** [support@whisperkool.com](mailto:support@whisperkool.com)

**Fax:** 209-466-4606

Visit [www.emersonclimate.com/electronicunitcontroller](http://www.emersonclimate.com/electronicunitcontroller) for online brochures, bulletins, instruction videos, and general product information.

**Download the Copeland Mobile App on your mobile device for additional troubleshooting and technical information.**



## ACCESSORIES FOR COOLING UNITS

WhisperKOOL offers accessories to enhance and customize your wine cooling unit:

### UV Air Purification Upgrade

The optional UV air purification kit provides chemical-free cleaning of the air from germs and microbes, inhibits the growth of mold and bacteria inside the cooling system, and optimizes system performance and longevity.

### Condensate Pump Kit

The condensate pump kit automatically removes water that drips out of the evaporator unit's drain line. The pump is controlled by a float/switch mechanism that turns the pump on when approximately 2¼" of water collects in the tank, and automatically switches off when the tank drains to approximately 1¼". The condensate pump kit allows the excess condensate to be pumped up to 20 feet away from the unit.

### Exterior Housing

If the cooling unit is installed outside, it will need protection from sun, wind, and rain. The exterior housing protects the condensing unit portion of the split system from the elements when installed outdoors.

**Accessories can be purchased at [www.whisperkool.com](http://www.whisperkool.com)**

**WhisperKOOL Product Terms and Conditions**  
**Including Product Limited Warranty And Product Installation Requirements**  
**For WhisperKOOL Split System Series**

ATTENTION: PLEASE READ THESE TERMS OF USE CAREFULLY BEFORE INSTALLING YOUR WHISPERKOOL COOLING SYSTEM. INSTALLING YOUR WHISPERKOOL COOLING SYSTEM INDICATES THAT YOU ACCEPT AND AGREE TO EACH OF THE TERMS AND CONDITIONS SET FORTH HEREIN ("TERMS OF USE"). IF YOU DO NOT ACCEPT THESE TERMS OF USE, YOU RISK VOIDING YOUR WARRANTY AND ASSUMING ADDITIONAL REPAIR AND REPLACEMENT COSTS.

**1. Purchase of a WhisperKOOL Cooling System assumes that the Purchaser ("End User") fully accepts and agrees to the Terms and Conditions set forth in this document. The Terms and Conditions of Sale and Owner's Manual are shipped with each unit and, if another copy is needed, replacement copies can be downloaded from the company website (whisperkool.com) or by contacting WhisperKOOL directly for a new copy. WhisperKOOL reserves the right, in its sole discretion, to change its Terms and Conditions at any time, for any reason, without notice.**

**2. WhisperKOOL Product Installation and Limited Warranty**

- A. Purchaser of the product must arrange for the product to be installed by a certified HVAC/R technician in accordance with procedures set forth by WhisperKOOL and described in the WhisperKOOL Owner's Manual.
- B. The HVAC/R technician installing the product must complete the designated portion of the Split Startup Checklist and provide licensing or certification identification number information to assist in the warranty registration process.
- C. Purchaser must return the completed Split Startup Checklist to WhisperKOOL within thirty (30) days of installation of Product. The Split Startup Checklist must be approved by WhisperKOOL to activate the Limited Warranty. If the Split Startup Checklist is approved, Purchaser will be sent activation approval documents and will start receiving the benefits of the Limited Warranty throughout the warranty period. If the Split Startup Checklist is incomplete, Purchaser will be informed they have five days to complete the Split Startup Checklist and re-submit to WhisperKOOL. The Split Startup Checklist will be reviewed again, and if denied, Purchaser will be informed that they have 10 business days for corrective action. Failure to register the Product may result in loss of warranty.
- D. Purchaser is responsible for the full costs of installation and any additional parts required for the proper and complete installation of the product.
- E. For Split Systems returned to WhisperKOOL in accordance with the terms and conditions of the Limited Warranty, WhisperKOOL warrants against defects in material and workmanship as follows:
  1. **LABOR** — For a period of two (2) years commencing on the date of purchase, WhisperKOOL will, at its option and discretion, reimburse up to \$250 to the End User for cost incurred for servicing, repairing, removing or installing warranty parts. Invoice for service must be forwarded to WhisperKOOL for assessment and processing. The Split System warranty is invalid if there is attempted repair by anyone other than an HVAC/R technician approved by WhisperKOOL to service the Product.
  2. **PARTS** — For a period of two (2) years commencing on the date of purchase, WhisperKOOL will supply, at no charge, new or rebuilt replacement parts in exchange for defective parts. Replacement parts are warranted only for the remainder of the original warranty period.
  3. **FREIGHT** — For a period of two (2) years commencing on the date of purchase, if after WhisperKOOL approved evaluation the original Product failure is determined to be the cause of a manufacturers defect, and not the cause of an installation error or other cause, WhisperKOOL will cover at its option, freight for the replacement parts or Product.

**The following part or cause of failure is not the responsibility of WhisperKOOL:**

- Improper voltage supply
- Line set with screw connectors (high end and low end)
- Leaks found at the braze points when performing pressure check
- Unit that has been charged incorrectly

- Incorrect tubing diameter used on line set
- A unit that has been wired incorrectly
- Valve stem on condenser side
- Improper installation of P-Trap
- Lack of P-Trap (if required)
- Condensers that are installed outdoors or in elements that would affect operation without proper cover or housing. (Housing is available from Manufacturer).

**Product Warranty Limitations and Exclusions.**

1. This limited warranty does not cover cosmetic damage caused during installation, damage due to acts of God, commercial use, accident, misuse, abuse, negligence, or modification to any part of the Product. Delivery and installation of the Product, any additional parts required, as well as removal of the Product if warranty work is required, are all at the sole cost, risk and obligation of the End User.
2. This limited warranty does not cover damage due to improper installation or operation or lack of proper maintenance of the Product, connection of the Product to improper voltage supply, or attempted repair of the Product by anyone other than a technician approved by WhisperKOOL to service the Product.
3. This limited warranty does not cover any Product sold "AS IS" or "WITH ALL FAULTS."
4. Product that has been replaced during warranty period does not extend the warranty period past the original date of purchase.
5. This limited warranty is valid only in the continental United States. Sales elsewhere are excluded from this warranty.
6. Proof of purchase of the Product in the form of a bill of sale, receipted invoice or serial number, which is evidence that the Product is within the Limited Warranty Period, must be presented by the End User to WhisperKOOL in order to obtain limited warranty service.
7. This limited warranty is void if the factory applied serial number has been altered or removed from the Product.
8. This limited warranty is voided if installed in an enclosure of insufficient design that does not follow the Product installation requirements stated herein and in the owner's manual.
9. Removing the rivets from the Product's unit housing without prior authorization from WhisperKOOL voids this limited warranty.
10. The End User must first contact WhisperKOOL Customer Service prior to attempting service on any Product still under the limited warranty; else the limited warranty is voided.
11. This limited warranty does not cover Product being concealed by, but not limited to, vegetation, fabric, shelving, mud, snow, or dirt. Product must not be painted or limited warranty will be void.
12. This limited warranty does not cover exposure to corroding environments such as, but not limited to, petroleum and gasoline products, cleaning solvents, caustic pool chemicals, and marine air.
13. This limited warranty does not cover any cause not relating to Product defect.
14. THE REPAIR OR REPLACEMENT OF THE PRODUCT AS PROVIDED UNDER THIS LIMITED WARRANTY IS THE EXCLUSIVE REMEDY OF YOU, THE END USER, AS WELL AS ANYONE ELSE IN THE CHAIN OF TITLE OF THE PRODUCT, DOES NOT START A NEW LIMITED WARRANTY TIME PERIOD, AND IS IN LIEU OF ALL OTHER WARRANTIES (EXPRESS OR IMPLIED) WITH REGARD TO THE PRODUCT. IN NO EVENT SHALL WHISPERKOOL BE LIABLE FOR INCIDENTAL, CONSEQUENTIAL, SPECIAL OR CONTINGENT DAMAGES FOR BREACH OF ANY EXPRESS OR IMPLIED WARRANTY ON THIS PRODUCT. THE IMPLIED WARRANTIES OF MERCHANTABILITY
15. AND FITNESS FOR A PARTICULAR PURPOSE ARE HEREBY EXPRESSLY DISCLAIMED. Some states do not allow the exclusion or limitation of incidental or consequential damages, or allow limitations on how long an implied warranty lasts, so the above limitations or exclusions may not apply to you. This limited warranty gives you specific legal rights, and you may have other rights, which vary from state to state.
16. Failure of the End User to comply with all of the Product Installation Requirements, Maintenance Requirements and End User Requirements may, at WhisperKOOL's sole discretion, void this limited warranty.
17. No one has any authority to add to or vary the limited warranty on this Product.



### **3. Maintenance Requirements**

The End User is responsible for checking the coils on the condenser unit and vacuuming them every three months to maintain them free of debris. It is the End User's responsibility to clean off any accumulated dust, lint, or other debris from the front and rear intake grills; failure to do this on a regular basis will restrict the airflow and may affect the Product's ability to function properly. Periodically cleaning the Product's vents will help assure maximum cooling efficiency. The drain tube must also be checked and kept clean and free of debris and mold to maintain proper performance.

Mold is a natural living organism in the environment. It exists in the air in the form of microscopic spores that move in and out of buildings through doors, windows, vents, HVAC systems and anywhere else that air enters. Once it is discovered, mold must be addressed quickly and appropriately. Delayed or improper treatment of mold issues can result in costly and reoccurring repairs. If the End User suspects a mold problem, it is always best to hire a qualified and experienced mold remediation specialist.

### **4. Additional End User Costs And Responsibilities**

#### **Terms and conditions for replacing the Product that is being evaluated for limited warranty.**

1. After evaluation by a certified HVAC/R technician and the Product is found to be irreparable in the field, contact WhisperKOOL Customer Service to arrange for replacement under the warranty guidelines. When a claim for warranty is submitted for a condenser skid, the End User must purchase a new condenser skid from WhisperKOOL at retail price. Upon installation of the new condenser skid by a certified HVAC/R Technician, the HVAC/R Technician must complete the Installation Checklist and End User must submit the Installation Checklist to WhisperKOOL Customer Service for approval. The original condenser skid must be returned within 21 days to WhisperKOOL for failure analysis. If the Installation Checklist is approved and the failure is evaluated as defective and not installation error or other reason, the End User will be refunded for the cost of the replacement skid.
2. If the Product failure is evaluated and it is determined that it is an installation error or other reason, all costs, including shipping will be the responsibility of the End User.

The following items are not covered under any warranty and are the sole responsibility of the End User:

- A. End Users should satisfy themselves that the Product they are purchasing is suitable for their particular needs and requirements, and thus no responsibility will be placed with WhisperKOOL for the End User's decisions in this regard.
- B. End Users must assure that the product is installed by a certified HVAC/R technician. Failure to do so will result in Voiding the Limited Warranty.
- C. It is the End User's responsibility to secure safe haven/storage for ANY AND ALL items that are being kept and stored in the End User's wine cellar, including any Product. WhisperKOOL takes no responsibility for the safety and preservation of the aforementioned items in the event that the environment becomes unsuitable to maintain a proper storage environment.
- D. End User is responsible for initial installation costs, including, but not limited to, labor costs and the cost of any additional parts necessary to complete the installation.
- E. End User is responsible for all costs incurred for the installation and/or removal of the Product, or any part thereof, unless such cost has been agreed by WhisperKOOL to be a warranty repair prior to the work being performed.

### **5. Sales and Use Tax**

WhisperKOOL only collects California sales tax for orders shipped within the State of California; WhisperKOOL does not collect sales tax for orders shipped to other states. However, the Purchaser and the End User may be liable to the taxing authority in their state for sales tax and/or use tax on the Product. The Purchaser and the End User should each check with their state's taxing authority for sales and use tax regulations.

### **6. Customer Service and Troubleshooting**

WhisperKOOL's customer service department is available to answer any questions or inquiries for End Users regarding a WhisperKOOL Product, as well as to assist in performing basic troubleshooting, Monday through Friday, from 6:00 a.m. to 4:00 p.m. PST, at [support@WhisperKOOL.com](mailto:support@WhisperKOOL.com). WhisperKOOL reserves the right to have a certified, WhisperKOOL-approved, HVAC/R technician go on site and inspect the product if the initial trouble shooting warrants further investigation. WhisperKOOL Corporation is located at 1738 East Alpine Avenue, Stockton, California 95205.

## 7. Request for Product Evaluation and Repair Under Warranty

**SPLIT SYSTEM FIELD SERVICE WARRANTY POLICY:** This Policy is to clarify what falls under Warranty Service and what becomes the responsibility of the Owner. WhisperKOOL (“manufacturer”) strives to provide our customers with a superior Product and we back our Product with a Two Year Limited Warranty. Please review the WhisperKOOL Product Terms and Conditions including Product Limited Warranty and Product Installation Requirements to ensure you have a complete understanding of our Policy and coverage of your Split System.

**ARBITRATION:** Any disputes arising out of or in connection with the installation and warranty of the Split System shall be referred to and finally resolved by a WhisperKOOL approved Independent Certified HVAC/R Technician. The evaluation of the Technician on all issues or matters of identifying the responsible party (WhisperKOOL or Installing Technician) shall be determined in a written report. This report will be made available to all concerned parties. If discovered under warranty, WhisperKOOL will assume the financial responsibility under their warranty guidelines. If the report finds the Owner’s Installer as the responsible party, WhisperKOOL will provide all documentation to the customer to substantiate the findings. This will include the Invoice from the Independent Certified HVAC/R Technician and the written report of the findings. The Owner will become responsible for payment directly to WhisperKOOL for all charges incurred for repairs (labor, parts and shipping costs) on the Split System.

## 8. Miscellaneous Terms and Conditions

- A. Return Policy. All return inquiries must be made within thirty (30) calendar days of the original purchase of a Product and are subject to a twenty five percent (25%) restocking fee. Shipping costs are not refundable and the Purchaser is responsible for all return shipping costs (including customs fees and duties, if applicable).
- B. Security Interest. WhisperKOOL retains a security interest in each Product until payment in full.
- C. Construction and Severability. Every provision of these Terms and Conditions shall be construed, to the extent possible, so as to be valid and enforceable. If any provision of these Terms and Conditions is held by a court of competent jurisdiction to be invalid, illegal or otherwise unenforceable, such provision will, to the extent so held, be deemed severed from the contract of sale between Purchaser and WhisperKOOL, and all of the other non-severed provisions will remain in full force and effect.
- D. Governing Law/Choice of Forum. The laws of the State of California (without regard for conflicts of law) shall govern the construction and enforcement of the these Terms and Conditions of Sale (Sections 1 through 9 inclusive, including Product Limited Warranty And Product Installation Requirements), and further these Terms and Conditions of Sale shall be interpreted as through drafted jointly by WhisperKOOL and Purchaser. Any dispute will be resolved by the courts in and for the County of San Joaquin, State of California, and all parties, WhisperKOOL, Purchaser and End User, hereby irrevocably submit to the personal jurisdiction of such courts for that purpose. No waiver by WhisperKOOL of any breach or default of the contract of sale (including these Terms and Conditions of Sale) concerning a Product will be deemed to be a waiver of any preceding or subsequent breach or default.
- E. Correction of Errors and Inaccuracies. These Terms and Conditions may contain typographical errors or other errors or inaccuracies. WhisperKOOL reserves the right to correct any errors, inaccuracies or omissions, and to change or update these Terms and Conditions, at any time without prior notice.

## 9. Questions, Additional Information And Technical Assistance

- A. Questions. If you have any questions regarding these Terms and Conditions or wish to obtain additional information, contact us via phone at support@WhisperKOOL.com or please send a letter via U.S. Mail to:

Customer Service  
WhisperKOOL Corporation  
1738 E Alpine Ave  
Stockton, CA 95205

E-mail: support@whisperkool.com  
Web: www.whisperkool.com

- B. Technical Assistance. WhisperKOOL Customer Service is available Monday through Friday from 6:00 a.m. to 4:00 p.m. PST. The Customer Service representative will be able to assist you with your questions and warranty information more effectively if you provide them with the following:
  - 1. The model and serial number of your WhisperKOOL UNIT.
  - 2. The location of the system and installation details, such as ventilation, construction of your wine cellar, and room size.

**Model** \_\_\_\_\_ **Serial Number** \_\_\_\_ \_

**Installed by** \_\_\_\_\_ **Date** \_\_\_\_\_

*Whisper***KOOL**<sup>™</sup>

WhisperKOOL  
1738 E. Alpine Ave  
Stockton, CA 95205  
[www.whisperkool.com](http://www.whisperkool.com)