

# MAGIX<sup>®</sup>

## X-TREME

# DATASHEET



## FOR GAMERS, ENTHUSIASTS AND HIGH-POWER USERS

X-TREME SSD provides cutting-edge performance in high capacities for gaming and hardware enthusiasts seeking extreme performance for PC builds and upgrades. Optimising the latest Gen 4x4 NVMe controller and 3D TLC NAND, X-TREME offers incredible speeds that reach up to 7200 MB/s in reading and 6800 MB/s in writing and up to 1,000,000 IOPS for fantastic consistency and exceptional gaming experience. From gaming and application loading times to streaming and capturing, X-TREME SSD will boost your system responsiveness. X-TREME matches the top-tier performance of the Magix memory line to produce the ultimate team to keep you at the top of your game.

To get the best from your Magix X-TREME, a Heatsink, sold separately, is strongly suggested.

X-TREME is available in multiple capacities from 512GB to 4TB to give you all the space you need for applications, videos, photos and other essential documents. You can also replace your hard drive or a smaller SSD with a drive big enough to hold all your files.

## OVERVIEW:

- > Fast start-up
- > Fast application loading
- > Fast file data transfer speed
- > More reliable and durable than a regular hard drive
- > Multiple capacities with space for applications or a hard drive replacement
- > Long life Cycle
- > Self-monitoring, Analysis and Reporting Technology (S.M.A.R.T.)
- > Support Power Management
- > Support power management
- > Support SMART and TRIM commands



# DATASHEET

## SPECIFICATIONS:

- > **Form factor:** M.2 2280
- > **Interface:** PCIe Gen4X4 NVMe
- > **Capacities\*:** 512GB, 1TB, 2TB, 4TB
- > **Read/Write performance\*\*:**
  - 512GB — up to 7000MB/s Read and 3000MB/s Write
  - 1TB — up to 7200MB/s Read and 6000MB/s Write
  - 2TB — up to 7200MB/s Read and 6800MB/s Write
  - 4TB — up to 7200MB/s Read and 6800MB/s Write
- > **Flash Type:** 3D TLC
- > **ECC Scheme:**  
PS5018-E18 PCIe SSD applies the fourth LDPC generation of ECC algorithm
- > **Storage temperature:** -40°C~85°C
- > **Operating temperature:** 0°C~70°C
- > **Operating voltage:** Min. 3.14V / Max. 3.47V
- > **Dimensions:**
  - Single side: 22.0mm x 80.0mm x 2.15mm
  - Double side: 22.0mm x 80.0mm x 3.50mm
- > **Weight:** 512GB/1TB/2TB/4TB - 7.7g/7.7g/7.8g/10.4g
- > **Life expectancy:** 1.6 million hours MTBF
- > **Warranty/support\*\*\*:** Limited 5 -year warranty with free technical support
- > **Total Bytes Written (TBW):**
  - 512GB — 350 TBW
  - 1TB — 700 TB W
  - 2TB — 1400 TBW
  - 4TB — 3000 TBW



## MAGIX PART NUMBERS:

- > **512GB:** XTREME512GB
- > **1TB:** XTREME1TB
- > **2TB:** XTREME2TB
- > **4TB:** XTREME4TB

\*1TB = 1,000,000,000,000/1 000 000 000 000/1.000.000.000.000 bytes.  
1GB = 1,000,000,000/1 000 000 000/1.000.000.000 bytes. Some of the listed capacity on a Flash storage device is used for formatting and other functions and this is not available for data storage. As such, the actual available capacity for data storage is less than what is listed on the products.

\*\*Performance measured using CrystalDiskMark 7.0.0 x64, write cache enabled, 1MB/sec = 1,048,576 bytes/sec ratio, msi X299 Chipset, Intel Core i7-7800K@3.5GHz, 32GB DDR4, Windows 10 x64 OS. Speed may vary due to host hardware, software, and usage.

\*\*\* Warranty conditions on [www.magixtechnology.com/wa](http://www.magixtechnology.com/wa)

# DATASHEET

## APPLICATION NOTES

### Wafer level Chip Scale Packaging (WLCSP) Precautions

There are a lot of components assembled on a single SSD device. Please handle the drive with care, especially when it has any WLCSP (Wafer Level Chip Scale Packaging) components such as PMIC, thermal sensor or load switch. WLCSP is one of the packaging technologies that is widely adopted from making smaller footprints, but any bumps or scratches may damage those ultrasmall parts, so, to handle gently is strongly recommended,

- ⚠ DO NOT DROP SSD
- ⚠ INSTALL SSD WITH CARE
- ⚠ STORE SSD IN A PROPER PACKAGE

### M Key M.2 SSD Assembly Precautions

M Key M.2 SSD is only compatible to M Key socket. Misuse may cause severe damages to the SSD including burn-out.

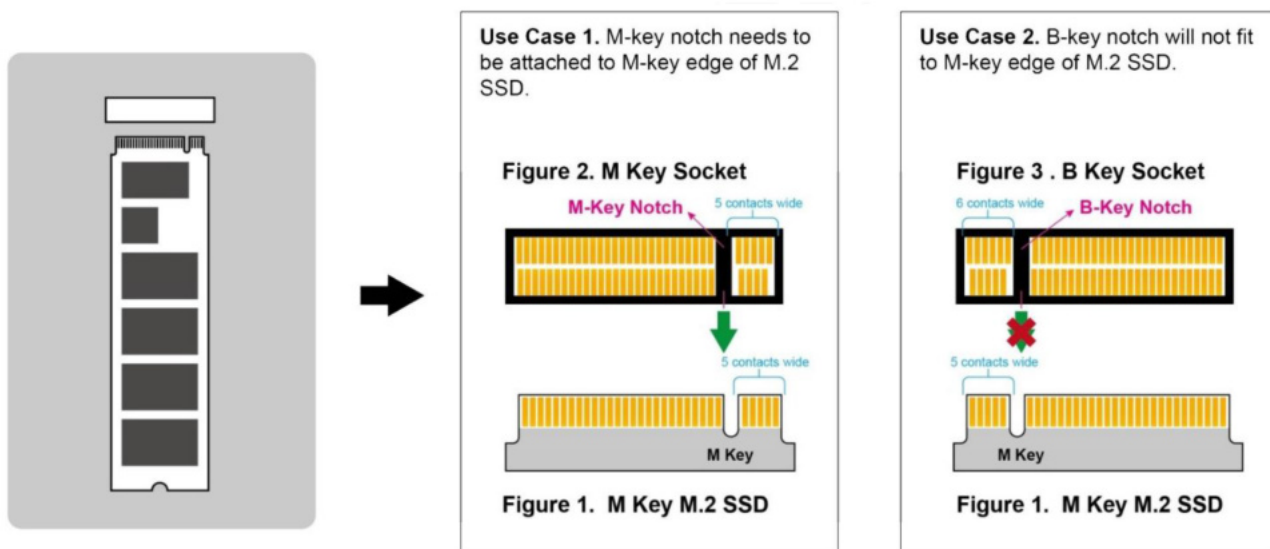

# DATASHEET

### CONTROLLER BLOCK DIAGRAM:

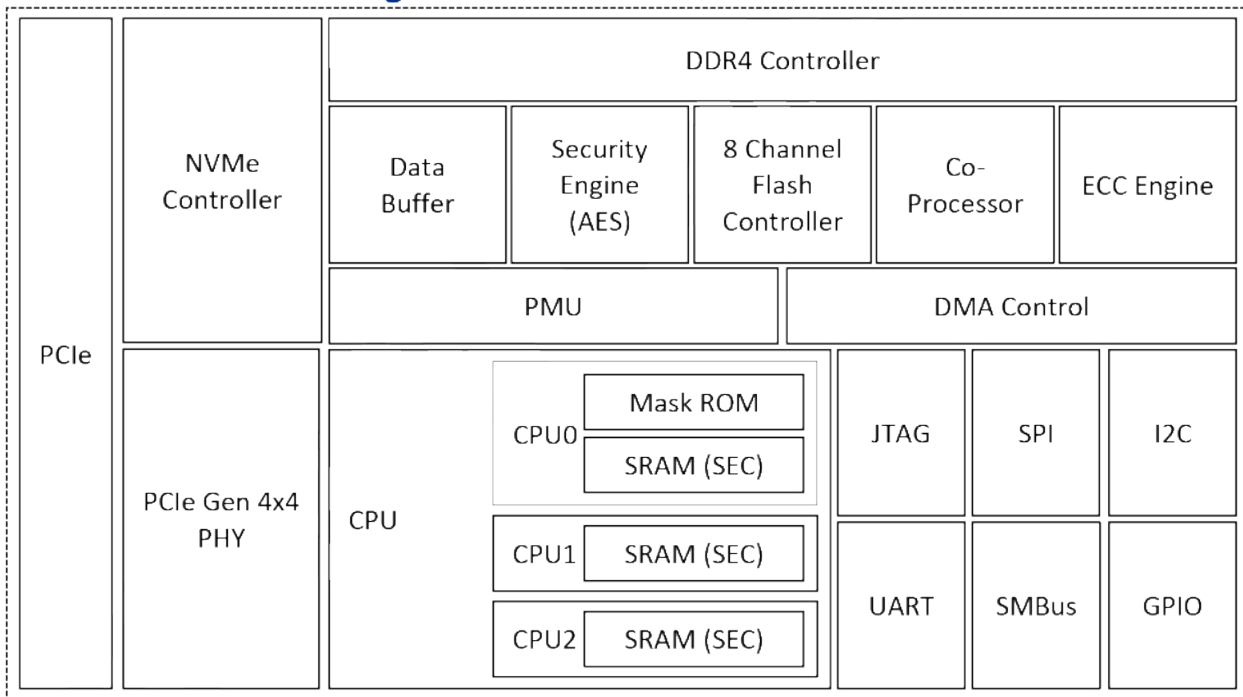

#### Notes:

- PMU: Power Managment Unit
- SEC: Single Bit Error Correct

### DATASHEET

#### PRODUCT BLOCK DIAGRAM:

Single side:

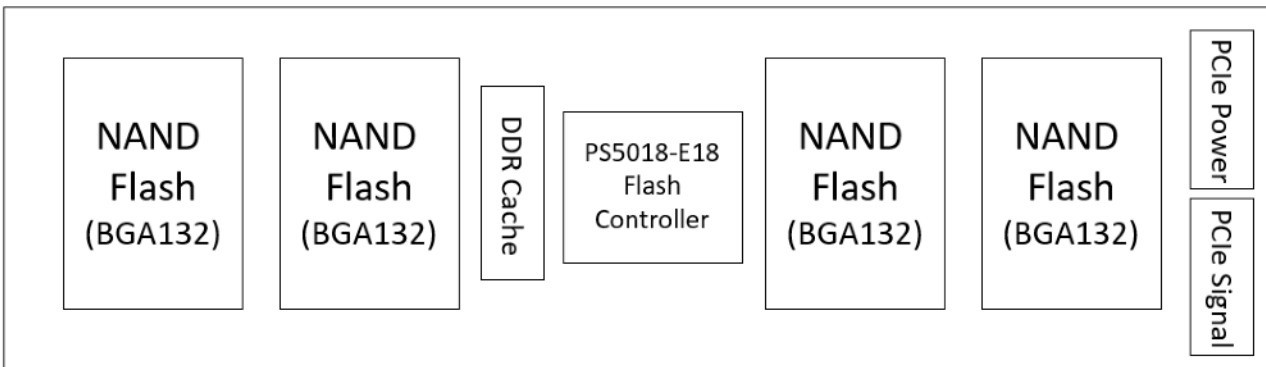

Double side: (Top)

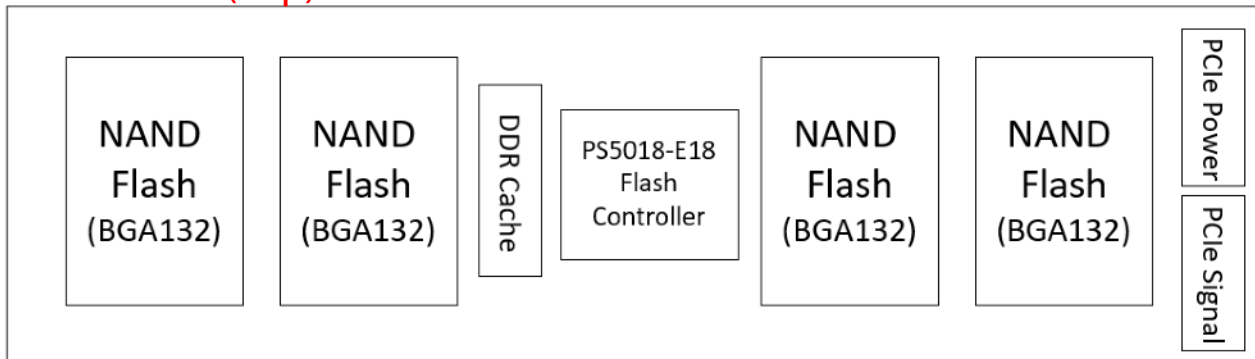

Double side: (Bottom)

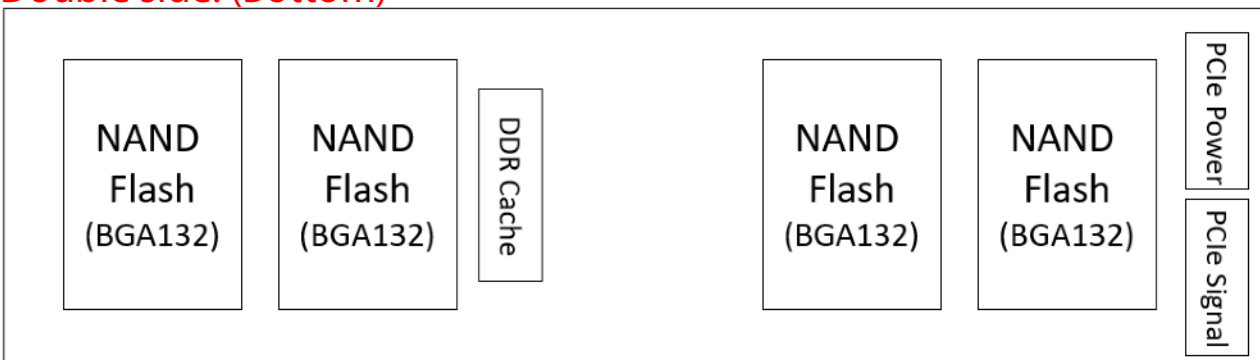

### DATASHEET

#### MECHANICAL DIAGRAM (Single side):

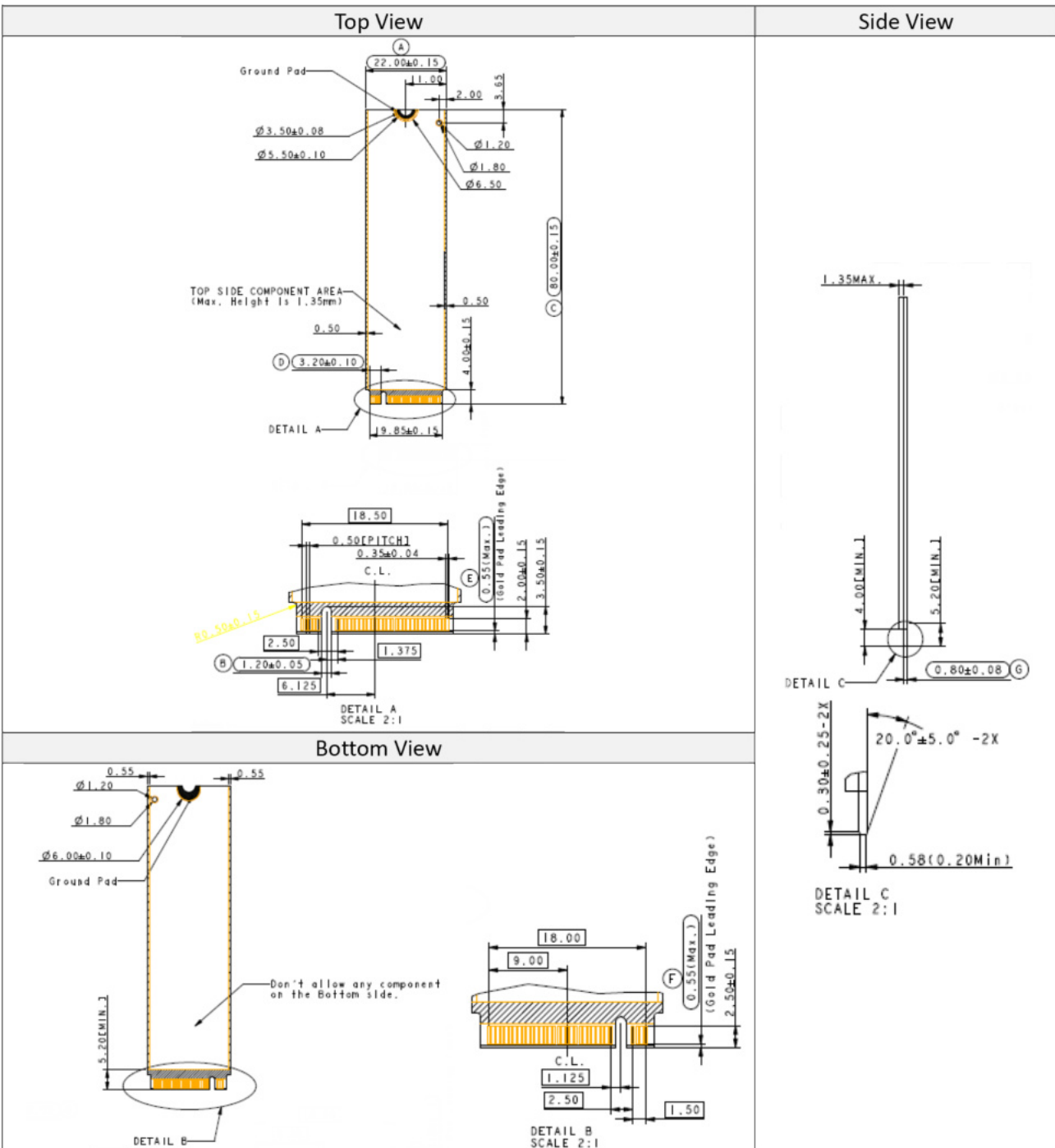

### DATASHEET

### MECHANICAL DIAGRAM (Double side):

