

ORIGINAL INSTRUCTIONS
XP380/XP380E-3/XP440E-3
GASOLINE ENGINE
OPERATOR'S MANUAL



Read this manual carefully before operation.
This manual includes important guidance for safety operation.

This Manual contains important safety information and instructions for operating this engine. **PLEASE READ THIS MANUAL CAREFULLY.** Failure to do so could result in property damage and/or personal INJURY/DEATH.

Provide this manual to any operator of this engine. This manual should be considered as a permanent part of your engine and should remain with it when you sell it.

All pictures&figures are only one example of series engine. It shall be only for reference and perhaps there will be difference between picture&figures and physical products.

All information in this publication is based on the latest product information available at the time of printing. We reserve the right to change, alter and/or improve the product and this document at any time without notice and without incurring any obligation.

No part of this publication shall be reproduced without written permission.

Write down the engine's serial number and purchase information. Keep this manual and the receipt for future reference.

Model:

Serial number:

Date of purchase:

Contents

I. Operator safety	1
II. Features and controls	5
III. Operating	6
1. Operating checklist.....	6
2. Starting the engine.....	10
3. Stopping the engine.....	12
IV. Maintenance	13
1. Maintenance schedule.....	13
2. General maintenance.....	15
3. Idle speed.....	18
4. Adjustment.....	18
V. Trouble-shooting	19
VI. Storage and transportation	20
VII. Specification	21
1. Specifications.....	21
2. Crankcase cover mounting size	22

I. Operator safety



Pay attention to this safety alert symbol. Obey all safety messages that follow this symbol to avoid possible property damage, INJURY or DEATH.

Each safety message is preceded by a safety alert symbol and one of three words, DANGER, WARNING, or CAUTION.

DANGER

Indicates a hazardous situation which, if not strictly complied with, will result in substantial property damage, serious injury or DEATH.

WARNING

Indicates a hazardous situation which, if not strictly complied with, may result in property damage, serious injury or DEATH.

CAUTION

Indicates a hazardous situation which, if not strictly complied with, could result in property damage or injury.



WARNING

READ THIS MANUAL COMPLETELY BEFORE OPERATING.

DO NOT operate this engine until you have read ALL safety, operation, and maintenance Instructions listed in this manual.

Failure to follow the instructions may result in property damage, INJURY or DEATH.

The warnings and precautions discussed in this manual cannot cover all possible conditions and situations that may occur. It must be understood by the operator that common sense and caution are factors which cannot be built into this product, but must be supplied by the operator.

WARNING

Do not modify the engine and do not use the engine for a purpose which it is not intended.

⚠ WARNING

Before each use, check for loose or damaged parts, signs of oil or fuel leaks, and any other condition that may affect proper operation. Repair or replace all damaged or defective parts immediately.

Locate all operating controls and safety labels.

Keep all safety guards in place and in proper working order at all times.

DO NOT overturn the engine with full oil or fuel.

DO NOT allow any material to block the cooling slots.

DO NOT allow children or untrained persons to operate the engine.

DO NOT run the engine unattended. Turn off the Engine before leaving the area.

⚠ DANGER

Do not tamper with the engine governed speed.

High operating speeds are dangerous and increase the risk of personal injury or damage to the equipment.

Operating at low speeds with heavy load may shorten the engine's life.



⚠ WARNING

FIRE

Operation of this engine may create sparks that can start fires around dry vegetation.

This engine may not be equipped with a spark arresting muffler. If the engine will be used around flammable materials, or on land covered with materials such as agricultural crops, forest, brush, grass, or other similar items, then an approved spark arrester must be installed.

In some area, a spark arrester is required by law. Please contact local fire agencies for laws or regulations relating to fire prevention requirements.



⚠ WARNING

KICKBACK

Rapid retraction of the starter cord will pull hand and arm towards the engine faster than you can let go.

Unintentional startup can result in accident.



⚠ WARNING

HOT SURFACE

Running engines produce heat. Severe burns can occur on contact.

Keep far away from hot exhaust.

DO NOT touch engine while operating or just after stopping. Avoid contact with hot exhaust gases.

Maintain at least three feet of clearance on all sides to ensure adequate cooling.

Combustible material can catch fire on contact. Maintain at least five feet of clearance from combustible materials.

⚠ WARNING

Read the instructions provided with the equipment that powered by this engine for any additional safety rules that should be observed in conjunction with engine startup, shutdown, operation, or protective apparel that may be needed to operate the equipment.



⚠ DANGER

FIRE OR EXPLOSION

Gasoline is highly flammable and extremely explosive.

Fire or explosion can cause severe burns or death.

Keep flammable items away while handling gasoline.

Fill fuel tank outdoors and in a well-ventilated area with the engine stopped.

Always wipe off spilled fuel and wait until the fuel has dried before starting the engine.

DO NOT operate the engine with known leaks in the fuel system.

Use proper fuel storage and handling procedures. DO NOT store fuel or other flammable materials nearby.

Empty the fuel tank before storing or transporting this engine.

Keep fire extinguisher handy and be prepared if a fire starts.



⚠ DANGER

MOVING PARTS

Moving parts can cause severe injury. Keep hands and feet away.

DO NOT operate engine with covers, shrouds, or guards removed.

DO NOT wear loose-fitting clothing, dangling drawstrings or items that could become caught. Tie up long hair and remove jewelry.

The moving parts may catch operator's hand, feet, hair and clothes such that will cause traumatic amputation or broken bones, fracture.

NEVER place fingers, hands, or body near the engine when it is running.



⚠ DANGER

TOXIC FUMES

The exhaust of the engine contains carbon monoxide, an odorless, colorless, poison gas. Using engine indoors **CAN KILL YOU!**

NEVER use inside any building or any kind of enclosure, **EVEN IF** doors and windows are open.

Place the engine in a well-ventilated area and carefully consider wind and air currents when positioning the engine.

II. Features and controls

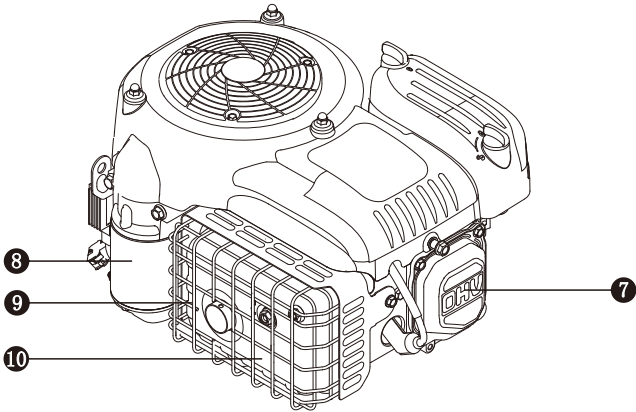
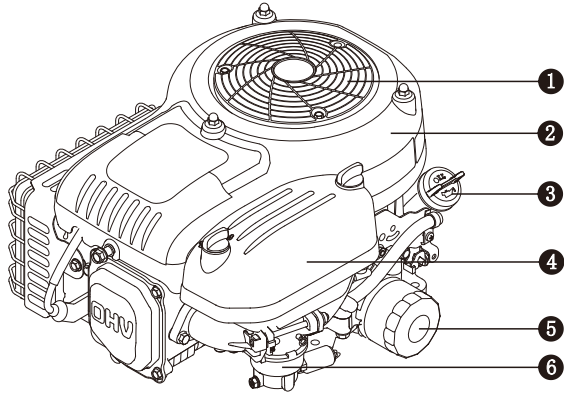

- | | |
|-------------------|---------------|
| ① Debris shield | ② Shroud |
| ③ Oil dipstick | ④ Air filter |
| ⑤ Fine oil filter | ⑥ Carburetor |
| ⑦ Valve cover | ⑧ Start motor |
| ⑨ Muffler shield | ⑩ Muffler |

III. Operating

1. Operating checklist

1 Operating location

Only use OUTSIDE and place the engine in a well-ventilated area and carefully consider wind and air currents.

Place the engine on level surface before any operation.



⚠ DANGER

TOXIC FUMES

The exhaust of the engine contains carbon monoxide, an odorless, colorless, poison gas. Using engine indoors CAN KILL YOU!

NEVER use inside any building or any kind of enclosure, EVEN IF doors and windows are open.

High altitude

This engine may require a high altitude carburetor kit to ensure correct operation at high altitudes. Consult your local dealer for high altitude kit information if you always operate your engine at altitudes above 5,000 feet (1,500 meters).

⚠ CAUTION

Even with carburetor modification, engine horsepower will decrease about 3.5% for each 1,000 feet (300 meters) increase in altitude. The effect of altitude on horsepower will be greater than this if no carburetor modification is made.

⚠ CAUTION

Operation the engine at altitude below 5,000 feet (1,500 meters) with modified carburetor may cause the engine to overheat and result in serious engine damage.

2 Operating condition

Check for loose or damaged parts, signs of oil or fuel leaks, and any other condition that may affect proper operation. Repair or replace all damaged or defective parts immediately.

⚠ WARNING

Failing to correct problem(s) before operation could result in property damage, serious injury or DEATH.

Remove any excessive dirt or debris, especially around the muffler and recoil starter.

Refer to operating instructions of equipment that this engine powers. Do not operate this engine exceeding maximum angle of operation; see specification table. Engine damage could result from insufficient lubrication.

3 Engine oil

Place the engine on a level surface with engine stopped.

Remove the dipstick and wipe it clean.

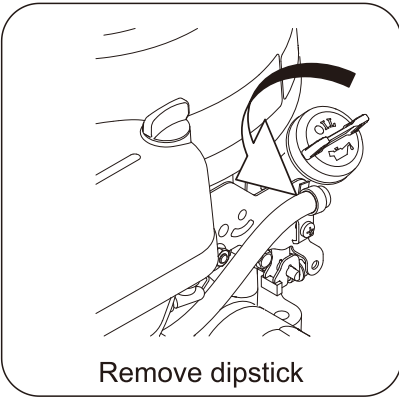

Reinstall dipstick into tube; rest on oil fill neck, DO NOT thread cap into tube.

Remove the dipstick again and check oil level. Level should be at least lay in the lower limit of indicator on the dipstick.

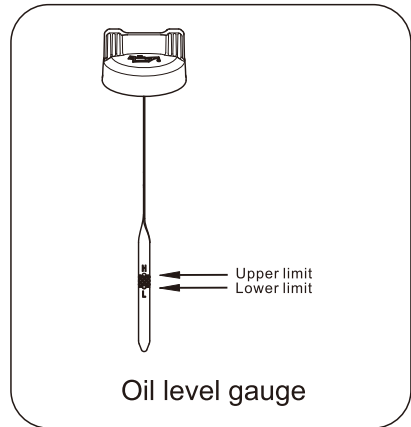

Fill to the upper limit (marked with “H”) of the dipstick with the recommended oil if the oil level is low.

Reinstall and fully tighten the dipstick.

Refer to add oil instruction in **MAINTENANCE** section for more information.

Oil capacity (rated):
See parameters.

⚠ WARNING

This engine is not filled with oil at the factory. Any attempt to crank or start the engine before it has been properly filled with the recommended type and amount of oil may result in engine damage and void your warranty.

⚠ WARNING

Oil is a major factor affecting performance and service life. Use 4-stroke automotive detergent oil recommended in the **MAINTENANCE** section of this manual.

**4 Engine fuel
(If equipment)**

With the engine stopped, check the fuel level gauge. Refill the fuel tank if necessary.

⚠ CAUTION

Pressure can build up in the fuel tank. Allow the engine to cool for at least two minutes before removing fuel cap. Loosen the fuel cap slowly to relieve any pressure in the tank.

Use clean, fresh, regular unleaded gasoline.

DO NOT mix oil with gasoline.

Be sure not to fill above the upper limit mark. Always allow room for fuel expansion.

**Fuel capacity (rated):
See parameters.**

⚠ DANGER

Do not fill the fuel tank above the upper limit. Over fill will result in engine die or damage the carbon canister (if equipped) and void your warranty.



⚠ DANGER

FIRE OR EXPLOSION

Gasoline is highly flammable and extremely explosive.

Fire or explosion can cause severe burns or death.

Keep flammable items away while handling gasoline.

Fill fuel tank outdoors and in a well-ventilated area with the engine stopped.

Always wipe off spilled fuel and wait until the fuel has dried before starting the engine.

DO NOT operate the engine with known leaks in the fuel system.

Use proper fuel storage and handling procedures. DO NOT store fuel or other flammable materials nearby.

Empty the fuel tank before storing or transporting this engine.

Keep fire extinguisher handy and be prepared if a fire starts.

NEVER use engine or carburetor cleaner products in the fuel tank or permanent damage may occur.

It is important to prevent gum deposits from forming in essential fuel system parts, such as the carburetor, fuel filter, fuel hose or tank during storage. Also, experience indicates that alcohol-blended fuels (called gasohol, ethanol or methanol) can attract moisture, which leads to separation and formation of acids during storage.

Acidic fuel can damage the fuel system of an engine while in storage. Be sure to review the instructions given in “Storage” chapter.

Gasoline/Alcohol Blends: up to 10% alcohol, 90% unleaded gasoline by volume is approved as a fuel. Other gasoline/alcohol blends are not approved. Effects of old, stale or contaminated fuel are not warrantable.

CAUTION

To minimize gum deposits in your fuel system and to insure easy starting, do not use gasoline left over from the previous season.

5 Equipment check

Check the equipment powered by this engine. Review the instructions provided by the equipment manufacturer for any precautions and procedures that should be followed before start the engine.

WARNING

This engine is designed and manufactured for specific applications. Do not attempt to modify the equipment or use it for any application for which it was not designed. If you have questions about specific application, ask your local dealer.

2. Starting the engine

1

Perform operating checklist.

2

Turn the fuel switch to “ON” position(if equipment). Turn the choke lever to off position(choke must be off when engine hot started).

3

Turn the throttle control lever to certain position, and then turn on the switch to start engine.

CAUTION

Choke plate need to be set in different width for temp. or other factors during engine start. choke should stay in the half open or full open width during re-start hot engine.

4

Manual starting

WARNING

Check starter cord conditions before operating. Have it replaced immediately by local authorized dealer if cord is frayed.

When starting engine, grasp the recoil starter handle and pull slowly until resistance is felt. Then pull rapidly to avoid kickback.



WARNING

KICKBACK

Rapid retraction of the starter cord will pull hand and arm towards the engine faster than you can let go.

Unintentional startup can result in accident.

After engine started, do not release the starter handle suddenly or it will hit engine heavily, it should be released slowly towards the direction of cord return in case of damage recoil starter. Operate engine in the tilt angle of 10 degree in all direction.

Electric start
(for applicable model)

Turn the key to the “START” position and keep moving up until engine starts. After engine starts, release the key and return it to the “ON” position.

If engine can not rotate by the electric starter, turn off the starter. Do not attempt to restart engine before trouble shooting. Do not restart engine with any battery replaced.

⚠ WARNING

Do not continuously start the engine for more than 15 seconds at a time. If engine fails to start, cool the starter for 1 minute before re-start. Otherwise, it may cause damage to the starting motor.

⚠ CAUTION

If engine cannot be started or shut down after start for three times, check to ensure that engine is placed on a horizontal surface and is filled with enough oil.

If engine is equipped with a low oil level sensor, when oil in the crankcase is below the minimum level, this will prevent the engine from start.

Make the oil routine inspection during the running-in. For the recommended maintenance intervals, see the section maintenance and servicing.

If engine speed is raised to the speed over starter but does not keep running (fails to start), then the engine must completely stop before start again. If flywheel starts to rotate automatically, but starter is still engaged, then

there may be a conflict between flywheel external gear and starter pinions, which may cause damage to the starter.

5

After engine started, choke plate should be slowly move to full "ON" position. Run engine under idle speed for (3-5) minutes, if engine running unstable(with engine shaking appearance), then move the choke plate to half "ON" position, and turn to full "ON" position till engine running stable.

⚠ CAUTION

When the engine is warming up, partially open the choke until engine temperature rises to a certain level.

3. Stopping the engine

1

If engine should stop when running with heavy load, remove all loads first and reduce engine speed, stop engine with turn the switch to "OFF/ON" position after engine idle running for (2-3)minutes. Remove the spark plug to force stop the engine if engine switch not work.

⚠ CAUTION

Directly stop the engine with loads is prohibited if it is not in abnormal conditions.

2

Turn the valve switch to "OFF" position if equipped.

IV. Maintenance

It is the owner's/operator's responsibility to complete all scheduled maintenance in a timely manner. Correct any issue before operating the engine. Always follow the inspection and maintenance recommendations and schedules in this manual.

WARNING

Improper maintenance or failure to correct a problem before operation can cause a malfunction and result in property damage, serious injury or DEATH.

Improper maintenance will void your warranty.

Before servicing the engine, stop the engine, disconnect all electric devices and battery (if equipped) and allow the engine to cool down.



DANGER

Accidental starts can cause severe injury or death. Remove and ground spark plug wire before performing any service.

CAUTION

The filter element may contain PAHs, PAHs are harmful for your health. Please wear gloves for protection during air filter maintenance.

1. Maintenance schedule

Stop engine before any servicing, disconnect all electric devices and battery (if equipped) and allow the engine to cool down.

Follow the service intervals indicated in the chart below. Service your engine more frequently when operating in adverse conditions.

Contact your local service dealer for your engine or engine maintenance needs.

		Each time before use	Every 10 hours or each month	Every 25 hours or each 3 months	Every 50 hours or each 6 months	Every 100 hours or each year	Every 200 hours or each 2 years
Oil	Check fuel level	•					
	Replace				•		
Air filter	Check	•					
	Clean			• ⁽¹⁾			
Spark plug	Check and adjust				•		
	Replace						•
Oil fine filter	Replace						• ⁽²⁾
Fasten like bolt and screw	Check	Tighten if needed					
Spark arrester	Clean					•	
Cooler	Check				•		
Max. no load speed	Check and adjust					• ⁽²⁾	
Valve lash	Check and adjust					• ⁽²⁾	
Combustion chamber	Clean	After 200 hours					
Fuel filter	Check					•	
Fuel tank	Check					•	
Fuel line	Check	Each 2 years(replace a new one if needed)					
Note: Set the maintenance schedule more reasonable when engine is used for commerce.							
(1)More frequent maintaining is required when engine run in the multi-dust or severe condition.							
(2)All maintaining should be done by experienced users or local authorized dealer if user is unable to maintenance or no tools.							

2. General maintenance

Engine oil

SAE 10W-30 is recommended for general, all-temperature use. Other viscosities shown in the chart may be used when the average temperature in your area is within the indicated range.

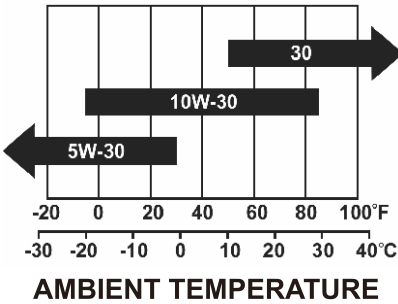

Oil capacity (rated):
See parameters.

Add oil

1. Place the engine on a level surface.
2. Remove the dipstick and wipe it clean.

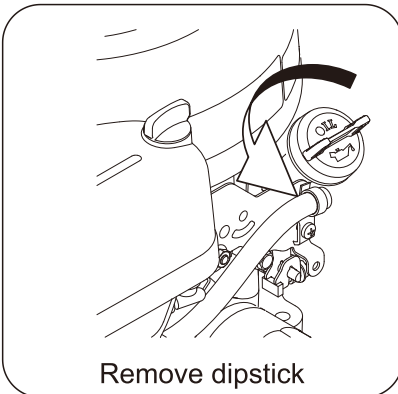

3. Add recommended oil to the upper limit.

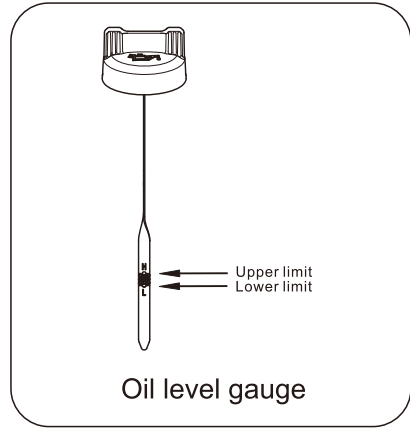

CAUTION

Oil level check

Reinstall dipstick into tube; rest on oil fill neck, DO NOT thread cap into tube.

4. Fully tighten the dipstick.

Change oil

CAUTION

Change oil when the engine is warm from operation.

1. Place the engine on a level surface.
2. Clean area around dipstick and drain plug.
3. Remove oil dipstick.

4.Remove the oil drain plug and allow the oil to drain completely.

5.Replace and fully tighten the drain plug.

6.Add recommended oil to the upper limit (see add oil instruction above).

7.Reinstall and fully tighten the dipstick.

8.Dispose of used oil at an approved waste management facility.

⚠ WARNING

The engine is not filled with oil at the factory. Any operation before it has been properly filled with the recommended type and amount of oil may result in engine damage and void your warranty.

Air filter

1.Remove the cover.

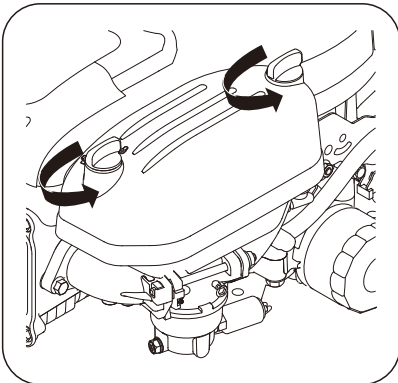

2.Remove the paper element.

3.Clean the paper element.

4.Put the element back to the whole assemble.

5.Tighten the filter cover and mounting if back to the assemble.

⚠ WARNING

Do not operation engine without air filter, or it will damage the engine.

⚠ CAUTION

Filter is a major factor affecting emission, do not temper with modified it in any form.

Do not run the engine without air filter mounting correct, if so, serious wear may happen to engine and void your engine warranty.

Do not blow paper element with high pressure blower.

Spark plug

1. Clean any dirt from the spark plug cap and spark plug base.
2. Remove the spark plug cap.
3. Using socket wrench to loose and remove the spark plug.
4. Inspect the spark plug and spark plug washer, if it's damaged or worn, replace with new one. Clean the spark plug with wire brush if reuse it.
5. Check spark plug gap. Carefully bend side electrode to adjust the gap if necessary.

Spark plug gap:

0.6mm - 0.8mm

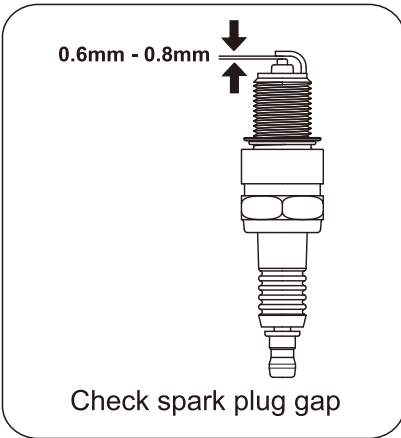

6. Carefully thread the plug into the engine by hand.

7. After the spark plug is seated, use spark plug wrench to tighten the plug.

**Spark plug tighten torque:
15-20 N.m**

8. Assemble spark plug cap back in to spark plug.

⚠ WARNING

Only use recommended spark plug or equivalent. **DO NOT** use spark plugs that have improper heat range.

Spark arrester

(Applicable types)

1. Allow the engine to cool completely before servicing the spark arrester.

2. Remove the two screws holding the cover plate which retains the end of the spark arrester to the muffler.

3. Remove the spark arrester screen.

4. Carefully remove the carbon deposits from the spark arrester screen with a wire brush.

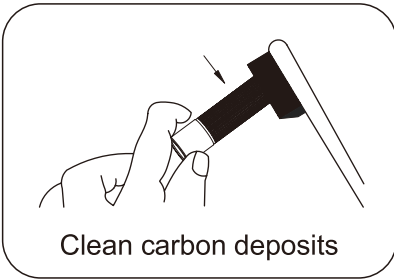

5. Replace the spark arrester if it is damaged.

6. Reinstall the spark arrester in the muffler and attach with the two screws.

3. Idle speed

The idle speed has been pre-set at the factory and should rarely require readjustment. Consult your local authorized dealer for such needs.

⚠ WARNING

Unapproved adjustment will damage your engine and/or your electrical devices and void your warranty.

4. Adjustment

There has no other service and/or adjustment need for your engine.

Unapproved adjustments or tampering can damage your engine and your electrical devices and will void your warranty. Contact your local dealer for such needs.

V. Trouble analysis and trouble-shooting

Un-starting or starting hard

Item		Problem shooting	Solution
No spark	Spark plug	Carbon store in spark plug	Remove carbon
		Spark plug and ignition gap large or small	Adjust to (0.6~0.8) mm
		Insulation damage	Change spark plug
	Others	Ignition damage	Change ignition
With spark	Good air and fuel ratio	Fuel insert over standard	Change fuel
	No fuel drain when loosen fuel drain bolt at carburetor bottom	Block in inner fuel pipe	Clean or change carburetor

Abnormal during engine running

Item	Problem shooting	Solution
Low power and rotate speed	Choke is not fully opened	Open the choke
	Low ignition power	Replace ignition or flywheel
	Over valve gap	Adjust the valve gap
	Carbon store in cylinder	Remove carbon
Unstable	Block in carburetor fuel pipe	Change carburetor
	Spark plug and ignition gap large or small	Adjust the spark plug gap
Abnormal sound	Wrong valve gap	Adjust or change related parts
Note: If engine can still not work after above operation, send it to authorized service dealer for maintaining.		

VI. Storage and transportation

Storage

The engine should be started at least once every 2 weeks and allowed to run for at least 20 minutes. Follow the instructions below for longer term storage if the engine will be out of service for 2 months or more.



Fire or explosion

Gasoline is highly flammable and extremely explosive. Empty the fuel tank and shut off fuel valve before storing or transporting this engine.

1. Change oil while engine is still warm from operation.
2. Allow the engine to cool completely.
3. Drain all fuel completely from the fuel tank, fuel hose and carburetor.
4. Remove spark plug and pour about 1 oz. of engine oil into cylinder. Reinstall spark plug. Crank engine slowly to distribute oil and lubricate cylinder.
5. Clean the engine according to the instructions in the Maintenance section.
6. Store the unit in a clean, dry area out of direct sunlight.

Transportation

To prevent fuel spillage when transporting or during temporary storage, the engine should be secured upright in its normal operating position, with the engine switch OFF. The fuel switch should be turned OFF.

WARNING

When transporting:

Do not over fill the tank. Avoid a place exposed to direct sunlight when putting the engine on a vehicle. If the engine is left in an enclosed vehicle for many hours, high temperature inside the vehicle could cause fuel to vaporize resulting in a possible explosion.

Do not drive on a rough road for an extended period with the engine on board. If you must transport the engine on a rough road, drain the fuel from the engine beforehand.

CAUTION

Take care not to drop or strike the engine when transporting. Do not place heavy objects on the engine.

VII. Specification

1. Specification parameter table

Category	Item	XP380/ XP380E-3	XP440E-3
Main structure parameters	Air valve arrangement	Overhead valve	Overhead valve
	Number of air cylinders	1	1
	Air cylinder diameter(mm)	84	90
	Piston stroke(mm)	69	69
	Total displacement(cm ³)	382	439
	Compression ratio	9.0:1	9.2:1
	Rated power(kW/min ⁻¹)	8.5/3600	9.5/3600
	Direction of rotation	Anticlockwise (From the PTO end direction)	
	Ignition advance angle(°)	20°±2°	20°±2°
	Valve clearance	Admission valve clearance (mm)	0.10-0.15
Emission valve clearance (mm)		0.10-0.15	0.10-0.15
Spark gap(mm)		0.6-0.8	0.6-0.8
Fuel and oil	Lubricating oil brand	SAE 10W-30	SAE 10W-30
	Fuel supplier	Carburetor oil supply	Carburetor oil supply
	Fuel capacity(L)	/	/
	Oil capacity(L)	1.4	1.4
Demission and mass	Demission(mm) (Length×Width×Height)	420×365×362	420×365× (294+80)
	Net mass(kg)	26	27

Notes: The gasoline engine with different specification and configurations may have different parameters and may change at any time without notice.

2. Crankcase cover mounting size

