



RIDE-ON MOWER

Models

A14011M

16.5HP, 19.5HP B&S 32" & 38"

A14111M

16HP HONDA 32" & 38"



OWNER/OPERATORS MANUAL

READ THIS MANUAL BEFORE OPERATING MACHINE

DEATH, PERSONAL INJURY AND/OR PROPERTY DAMAGE MAY OCCUR UNLESS INSTRUCTIONS IN THIS MANUAL ARE FOLLOWED

NOTE: Bring this Manual when Service & or Warranty work is required.

LAWN BOSS

OWNERS INFORMATION

MACHINE CODE NO: _____

SERIAL NO: _____

Located on label inside transmission housing

B&S ENGINE MODEL NO: _____ **TYPE** _____ **CODE** _____

HONDA ENGINE TYPE NO: _____ **SERIAL NO** _____

Located on engine refer Engine Owners Manual

DATE OF PURCHASE: _____

ISSUED TO:

OWNERS NAME: _____

ADDRESS: _____

TOWN/CITY: _____ **STATE:** _____

ISSUED BY:

**AUTHORISED DEALER/
DISTRIBUTOR:** _____

ADDRESS: _____

TOWN/CITY: _____ **STATE:** _____

PRE DELIVERY CHECK LIST

Check parts Assemble Service Instruction

ALWAYS KEEP THIS MANUAL IN A SAFE PLACE.

SAFETY INSTRUCTIONS

- Read, understand, & follow all instructions in the Owner/Operators manual.
- Know the controls and how to stop the engine quickly in an emergency.
- Allow only responsible adults, who are familiar with the instructions in this manual, to operate the machine.
- Clear the area to be mowed of loose objects such as sticks, stones, bones, wire, toys, debris, etc., which could be picked up and thrown by the blades.
- DO NOT mow whilst people, especially children, or pets are in the mowing area.
- DO NOT mow either direction on slopes beyond 15 degrees (1 in 3.75).
- Exercise extreme caution on slopes.
- Reduce speed on slopes and in sharp turns to prevent overturning or loss of control.
- Start or stop slowly when on slopes.
- Mow up and down slopes, not across the slope.
- Stay alert for holes or bumps in the terrain and other hidden hazards.
- Watch out for traffic when crossing or operating the mower near roadways.
- Stop the blades rotating before crossing surfaces other than grass.
- When using attachments, never direct discharge of material toward bystanders nor allow anyone near the machine while it is in operation.
- Before leaving the operators position-
 - a] Disengage all clutches and secure cutting units;
 - b] Return drive pedal to neutral position and set the parking brake;
 - c] Stop the engine and remove the key.
- Disengage drive to attachments and stop engine-
 - a] Before refueling;
 - b] Before checking, cleaning or working on the mower;
 - c] After striking a foreign object (check the mower for damage and make repairs before restarting and operating the equipment);
 - d] If machine starts to vibrate abnormally (check immediately).
- Disengage drive to attachments when transporting or not in use.
- A mower operator should be in good physical and mental health and not under the influence of alcohol or any drug which might impair vision, co-ordination or judgment.
- Never mow while barefoot or wearing open sandals or thongs. Wear long trousers and heavy shoes.
- It is advisable to wear suitable eye protection when operating a mower.
- Mow only in daylight or good artificial light.
- Before using, always visually inspect to see that blades, bolts and cutter assembly are not worn or damaged. Replace worn or damaged blades and bolts in sets to preserve balance.
- Check all nuts, bolts, and screws often; always be sure the mower is in safe operating condition.
- Keep safety devices (guards and switches) in place and in working order.
- Never use the mower unless the guards provided by the manufacturer, are in position.
- Ensure any replacement parts used comply with the original manufacture's recommendations and specifications.
- Replace worn or faulty silencers.
- Keep machine free of grass, leaves or other debris, excessive oil, grease, or spilt fuel. These can be a fire hazard.
- Refuel outdoors only. Do not smoke while fueling engine. Never remove the cap of the fuel tank or add petrol while the engine is running or the engine is hot. Remove fuel cap slowly to relieve any tank pressure. If fuel is spilled, do not attempt to start the engine but move machine away from the area of the spill and avoid creating any source of ignition until fuel vapors have dissipated.
- Check for fuel leaks while refueling, before and while using the mower. If a fuel leak is found, do not start or run the engine until the fuel leak is fixed and spilled fuel is wiped away.
- Do not operate engine in a confined space where exhaust fumes (carbon monoxide) can collect.
- Always mount the mower from the left or the opposite side to the discharge chute.
- Start the engine carefully with the cutting means disengaged.
- Do not over-speed the engine or alter governor settings. Excessive speed is dangerous and shortens mower life.
- Stop the engine whenever you leave the mower, even for a moment.
- Store the mower in a well-ventilated room away from naked flames such as may be found in hot water heaters.
- Do not lend or sell the mower, without the owners/operators Manual.

PRE-DELIVERY INSTRUCTIONS

INTRODUCTION:

The purpose of this procedure is to ensure the dealer/distributor has made the necessary installations, adjustments and checks, before the machine is operational. This procedure begins upon receiving the crated mower and is finalised once the mower has been either sold or leaves the dealer/distributors premises. This is the minimum amount of work required, however it should not be limited to only the areas detailed in this procedure.

RESPONSIBILITY:

It is the responsibility of the dealer/distributors to ensure that before a machine is delivered to a customer, it is in perfect operational condition.

PROCEDURE:

CHECK ACCESSORIES SUPPLIED IN SEAT PROTECTION BAG

- Engine owners manual
- Owner/Operator manual
- Ignition keys (AM015)
- Spark plug spanner (AM295)
- Spark plug spanner (AM005G0 16HP Honda)
- Spark plug Spanner 13HP Honda
- Tommy bar (AM007)
- Steering wheel (SW13)
- Roll Pin (DP10)
- Set Screws M8X20 X 2
- Nuts M8 Nyloc x 2
- Seat Springs x 2 (13060)
- Washer W05M202 x 2
- Warranty Card
- Pre-delivery Instruction Sheet

Remove the four seat bolts, shakeproof washers and plain washers to remove the plastic bag protection from around seat. Install the four seat bolts, shakeproof washers and plain washers, making sure that the seat is adjusted into the desired position by using the seat transmission slots, tighten bolts.

TYRE PRESSURE

Before operation ensure that all tyre pressures are equal. The maximum pressure allowed is 140 kpa (20 P.S.I.).

ENGINE OIL

Before operation ensure that engine oil level is to the full mark on the dipstick. (Check engine owners manual if oil needs to be added).

Bonnet shown in closed position underneath dash panel extension before attaching bonnet strap.

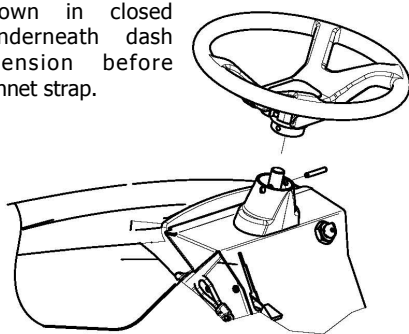

Roll Pin type steering wheel

FUEL TAP

Ensure the fuel tap at the bottom of the LH side of fuel tank is turned to the on position before attempting to start engine. (Use unleaded fuel only).

Turn off fuel tap after use.

ASSEMBLE STEERING WHEEL TO MOWER

Roll Pin Type—To attach the steering wheel, align the hole in the steering wheel boss to the hole in the steering shaft and use a hammer and suitable punch to drive the DP10 roll pin in, through the hole in the steering shaft cover into the steering wheel and shaft. Ensure that the pin is situated centrally in the steering wheel boss and that the steering is free to turn.

Keyed Type— Remove tape attaching woodruff key to steering shaft. Remove the screw & washers attached to the steering shaft. Lubricate taper on steering shaft with grease or anti-seize. Place steering wheel with keyway aligned with woodruff key on shaft. Assemble the screw and washers onto the shaft with 1/2" a/f socket, extension & wrench & tighten to 23Nm.

Press the steering wheel center cover into place using hand pressure only.

SEAT SPRINGS

Install and tighten the two seat springs, bolts and nuts to the bracket welded to the rear of the chassis, which is situated under the seat/transmission cover.

SAFETY SWITCHES

Park brake switch - With cutter lever disengaged, attempt to start the engine without setting the park brake. Engine should not start.

Disengagement Switch - While sitting on machine with park brake set and cutter engaged, attempt to start machine. Engine should not start.

Seat Switch - While sitting on machine start engine, engage cutter and lift weight from seat. Engine should cut out.

CUTTER BELT

Ensure that when the cutter belt is in the disengaged position that the belt does not overlap when squeezed together, if this occurs adjust the cutter engage lever until correct disengagement is achieved.

OPERATING INSTRUCTIONS

IMPORTANT RECOMMENDED FUEL

Unleaded fuel is recommended by all manufacturers of engines fitted to Cox products.

SAFETY MICRO SWITCHES

Before operating machine, ensure that all micro-safety switches are operating correctly. Do not operate machine with faulty, missing or damaged safety micro-switches.

STARTING MACHINE

When starting machine; Ensure parking brake is set. Ensure that cutter is disengaged, otherwise electric starter motor will not engage. If engine is cold move throttle to cold start position and return to desired throttle setting when engine starts. Do not attempt to operate engine with throttle lever in cold start (choke) position. (Note electric start engines fitted with recoil can be manually started with cutter disengaged and ignition on).

BLADE WARNING

Do not use mowing attachment with broken or bent blades, damaged or worn bolts and nuts or damaged cutter disc, otherwise damage and premature wear will result from vibration. Replace blades, bolts and nuts only in pairs to maintain correct balance. Recommended blade nut torque is 36-40Nm. Do not over tighten.

Keep both feet and hands clear at all times of the mowing attachment while attempting to start or operate the machine.



**WARNING
DO NOT OPERATE WITHOUT MOWING
ATTACHMENT DEFLECTOR FITTED & DOWN.**

Safety footwear is recommended when operating machine. Mount and dismount only from left hand side of machine. Reference to left or right hand side of machine is determined by sitting in the operating position on the machine. Ensure machine has parking brake engaged when attempting to start engine.

Never allow engine revs to exceed more than 3600 RPM.

TO OPERATE

BEFORE STARTING/SWITCHING OFF:

See Engine Maintenance/Instruction Sheet. When stopping engine disengage cutter return throttle to slow position and switch off

ENGAGING & DISENGAGING MOWING ATTACHMENT:

The Disengaging lever is situated on the right hand side by the steering column. Before starting, disengage mowing attachment by pulling lever fully to the operator. Before engaging mowing attachment ensure cutter height adjustment is in high position. Select preferred cutting height after engaging mowing attachment. For safety it is advisable at all times, other than when mowing, that the mowing attachment be kept in the disengaged position.

TO DRIVE FORWARD/REVERSE:

Power is regulated by the throttle, set throttle control to desired engine power. Press down on the forward section of the drive pedal for forward movement, on the rear of the drive pedal for reverse. The amount of movement controls the ground speed, less movement from the neutral position results in less ground speed, use this feature especially in heavier conditions.

MANOEUVRING:

The forward and reverse operation makes the machine very manoeuvrable and the sharpest turns can be negotiated easily and quickly, however;

Owing to the hydrostatic transmission, when manoeuvring the machine you must allow the machine to come to a complete stop before moving off in the opposite direction. This means that if you are travelling forward and need to reverse out of an area etc, you must return the pedal to the neutral position come to a complete stop and then select reverse drive and Vice Versa for travelling from reverse to forward.

TO BRAKE:

The drive pedal may be used to slow/brake the machine. If travelling forward ease the pedal back into the neutral position and the machine will slow and stop. When travelling in reverse ease the pedal forward into the neutral position. Should a failure to drive occur during operation use the brake pedal situated on the left side of the mower.

PARKING AND TRANSPORTATION BRAKE:

TO ACTIVATE: Fully depress the brake pedal situated at the left side of the mower. Raise park brake knob protruding out of the right hand side of the console and release brake pedal to engage the park brake in lock & release knob. Depress pedal and the mechanism will release.

Do not engage parking brake unless the machine has completely stopped.

Do not attempt to drive with park brake engaged.

CUTTING HEIGHT ADJUSTMENT:

The height adjustment lever is located on the left hand side of the machine and may be altered to suit varying conditions.

NOTE: When mowing slopes, keep drive pedal in forward or reverse, depending on direction of travel. The low gearing will prevent it from picking up excessive speed. If very steep it may be necessary to throttle back slightly and /or, decrease pedal travel.

MAINTENANCE INSTRUCTIONS

It is the owner's responsibility to ensure that all-periodical checks, necessary adjustments and services are carried out.

STOP ENGINE - Never attempt any maintenance with the engine running, remove spark plug lead and ensure the blades have stopped rotating. Before servicing, disconnect spark plug wire and ground it, disconnect battery at negative terminal, to prevent accidental starting.

1. OIL CHANGING & FILTER REPLACEMENT (ENGINE): See Engine Maintenance/Instructions Sheet and carry out as per Engine Manufacturers Recommendations.

SERVICING ENGINE AIR CLEANER FOAM PRE-CLEANER— See engine owners manual for correct method to check and service engine air cleaner and or foam pre-cleaner.

TRANSAXLE— Type of Oil- top up with 10w30 oil At 50 hours replace with 5W50 synthetic oil and every 250 hours thereafter— Quantity 2300mls.

2. LUBRICATION OF MACHINE: Lubrication of machine must be carried out every 25 hours of operation or once a month, whichever falls first. More frequently when operated under adverse conditions.

A. OILING: A few drops of oil should be placed at the following points: Steering linkages and pivot points, disengaging linkages and height adjustment mechanism.

B. CHAIN: Use only chain lube for lubrication of the steering chain.

3. TO CHECK BLADES: Stop engine. Remove spark plug lead. Side Discharge Only, lift deflector and height adjustment control to highest position. If necessary simply remove the blade bolt and nut using a suitable spanner and replace worn parts.

4. ENGINE TO PTO VEE BELT ADJUSTMENT: Loosen the four engine mounting bolts. Move engine forward and adjust belt firmly. Do not over tension. While maintaining tension on the engine re-tighten bolts. Check belt tension at machine service period (25hrs B&S) (50hrs Honda) or more frequently under heavy mowing conditions.

5. PTO TO CUTTER VEE BELT ADJUSTMENT: Tension is automatically adjusted by the belt tensioning springs. However, as the belt stretches it will be necessary to lower the rear of the cutter housing by loosening the rear lifting link nut, and visa versa when a new belt is fitted.

6. CUTTER HEIGHT ADJUSTMENT: If the Mowing Attachment can not be positioned to give a satisfactory grass cut height using the available notches on the chassis the adjustable link can be used to raise the Mowing Attachment to the desired height. Position the mower on a smooth level surface and engage the mowing attachment, lock the park brake on, and lower the Mowing Attachment to the notch above the desired cut height. Place equal height spacers of the desired height under the mowing attachment that can support the mowing attachments weight and lower the Mowing Attachment onto them. Loosen the 2 Screws located together on the front of the Rear Link located below the front of the left foot rest. Push the Rear Link rearwards until it stops and retighten the 2 screws. Adjust the rear lifting link located on the middle rear of the mowing attachment by tightening the nut until it just lifts the rear of the mowing attachment of the spacers. Lift the Mowing attachment off the spacers and remove the spacers and check the cut height is as desired and the deck is level to slightly higher (3—5 mm) at the back. Adjust height again if required.

7. CUTTER BRAKE ASSEMBLY ADJUSTMENT: With disengagement handle in engaged position and mowing attachment in low cut, normal clearance between cutter head pulley and cutter head brake pad is approximately 3mm (1/8"). To adjust clearance, remove 'R' pin from brake pull rod, adjust to give required clearance, replace brake pull rod and 'R' pin. Check operation after adjustment.

8. DISENGAGING ADJUSTMENT: With the engine switched off,

engage the mowing attachment, then fully lower. Place a straight edge vertically against the front of the front axle beam and in line with the disengagement lever. Measure the distance between the straight edge and the 8mm dia pin fitted with the small 'R' pin for the threaded adjuster. Disengage mowing attachment and using the same method, check the new distance. The difference should be 20 – 22mm. Engage mowing attachment, remove 'R' pin and adjust threaded adjuster accordingly. Install 'R' pin and re-check measurement. Due to normal wear in transmission to cutter vee belt, the disengagement lever will move lower and touch the foot rest. When this occurs the amount of travel will need to be re-adjusted. If a new vee belt is installed the above settings will apply. Start engine and raise cutter to full height stop, cutter belt should not engage. If this occurs switch off engine, engage cutter then screw adjuster out 1 – 2 turns then retest.

9. TO ADJUST STEERING CHAIN: Adjust chain by loosening the four bolts which hold the steering idler shaft mounting brackets (AM255) in position, slide forward to tension chain then retighten bolts.

10. TO REMOVE MOWING ATTACHMENT: Fully lower mowing attachment and engage, remove weight compensating spring, remove 'R' pin from rear lifting link and disconnect, remove 'R' pin from cutter brake adjusting rod and disconnect, disengage mowing attachment, remove belt, remove front pivot pin, Turn steering wheel to the left to slide out mowing attachment. To refit, reverse the above.

11. MOWING ATTACHMENT VEE BELT ADJUSTMENT: Automatic by springs on mowing attachment.

12. TYRE PRESSURE: 140 Kpa (20.P.S.I.) approximately front and rear. Uneven pressure can give an uneven finish when mowing and may cause damage to tyres and/or tubes.

13. BATTERY MAINTENANCE: Maintain electrolyte fluid level just above plates by topping regularly with distilled water. When not in use, a battery discharges by as much as 1% a day, more when the climate is warm. To make up for this loss, a boosting charge should be given once a month. Disconnect battery terminals to charge, then allow to stand minimum 1/2hr before re-connecting (re-check electrolyte level). If a battery is not used for a period of more than three (3) months, the terminals should be disconnected and trickle charged at two (2) amps for two (2) hours once every three (3) months or before use.

14. SEAT ADJUSTMENT: Loosen four seat mounting bolts and slide seat into desired position in slots and re-tighten bolts.

15. CLEANING AND POLISHING POLYETHYLENE BONNET AND REAR MUDGUARD: To keep scratches on bonnet and mudguard to minimum, do not rub or brush off with bare hands, use a soft cloth or a light flow of compressed air. For dirt, wash with a steady stream of water only (no detergent), then blow off excess water with air. To polish remove excess dust or dirt. When surface is dry, spray on an automotive type plastic preservative and leave on for 30 to 60 seconds. Using a dry soft cloth (i.e. cheesecloth) wipe off to bring up lustre.

16. GENUINE SPARE PARTS: Always use Genuine Cox Factory Made Spare Parts. Use of non-genuine COX spares will void your warranty.

17. SAFETY FIRST: The use of any mechanical appliance can cause injury if incorrect procedures are used. Please ensure that all family members of intended operators read this manual thoroughly.

TORQUE SETTINGS

1/4" UNC BOLT/NUT	10Nm (84lbf in)
5/16" UNC BOLT/NUT	20Nm (180lbf in)
3/8" UNC BOLT/NUT	36Nm (27lbf ft)
7/16" UNF BOLT	68Nm (50lbf ft)
6mm BOLT/NUT	9Nm (80lbf in)
20mm NUT	100Nm (74lbf ft)
5/8" UNF NUT	100Nm (74lbf ft)

We are proud that you have purchased a Cox product and urge you to follow these instructions to obtain the maximum life for your machine. If in doubt check with your supplier.

MAINTENANCE SCHEDULE

BEFORE EACH USE & EVERY 5 HOURS

Check engine oil level, adjust if required
Check engine air cleaner foam pre-cleaner, service if required
Check engine rotating screen/finger guard, clean if required
Check operation of safety switches, service if required
Check foot brake operation
Check tyre pressures, adjust if required

Check for loose fasteners, tighten if required
Lubricate stub axles
Check mowing attachment cutter blades, bolts, nuts, disc/s, housing, and guards for wear or damage, replace if required
Check transaxle vent cap and oil

BEFORE EXTENDED STORAGE

Change engine oil - Clean machine - Lubricate as per required

EVERY 5 HOURS

Check engine oil level, adjust if required
Check engine air cleaner foam pre-cleaner, service if req.
Check engine rotating screen/finger guard, clean if required
Check operation of safety switches, service if required
Check foot brake operation
Check tyre pressures, adjust if required

Check for loose fasteners, tighten if required
Lubricate stub axles
Check mowing attachment cutter blades, bolts, nuts, disc/s, housing, and guards for wear or damage, replace if required

1 MONTH OR 5 HOURS WHICH EVER OCCURS FIRST

Change engine oil
Check engine air cleaner foam pre-cleaner, service if required
Check engine rotating screen/finger guard, clean if required
Check foot brake operation, adjust if required
Check operation of safety switches, service if required
Check tyre pressures, adjust if required
Lubricate stub axles
Check mowing attachment cutter blades, bolts, nuts, disc/s, housing, and guards for damage, replace if required

Check and adjust engine to transmission vee belt if required..
Check for loose fasteners, tighten if required
Check transmission to cutter vee belt and adjust cutter housing level if required

DATE / / HOURS.....DEALER.....

3 MONTH OR 25 HOURS WHICH EVER OCCURS FIRST

Change engine oil if operating under heavy load or high ambient temperature
Check engine air cleaner foam pre-cleaner, service if required *
Check engine rotating screen/finger guard, clean if required *
Check foot brake operation
Check operation of safety switches and replace if required
Check tyre pressures, adjust if required
Lubricate stub axles
Check mowing attachment cutter blades, bolts, nuts, disc/s, housing,

and guards for wear or damage, replace if required
Check and adjust engine to transmission vee belt if required..
Check battery condition, service if required
Check transmission to cutter vee belt and adjust cutter housing level if required
Check for loose fasteners, tighten if required

*Service more often under dusty conditions, or where air borne debris is present

DATE / / HOURS.....CUSTOMER.....

6 MONTH OR 50 HOURS WHICH EVER OCCURS FIRST

Change engine oil if operating under heavy load or high ambient temperature
Check engine air cleaner foam pre-cleaner, service if required *
Check engine rotating screen/finger guard, clean if required *
Check foot brake operation
Check operation of safety switches and replace if required
Check tyre pressures, adjust if required
Lubricate stub axles
Check mowing attachment cutter blades, bolts, nuts, disc/s, housing, and guards for wear or damage, replace if required

Check for loose fasteners, tighten if required
Check and adjust engine to transmission vee belt if required..
Check battery condition, service if required
Check transmission to cutter vee belt and adjust cutter housing level if required

*Service more often under dusty conditions, or where air borne debris is present

DATE / / HOURS.....DEALER.....

9 MONTHS OR 75 HOURS WHICH EVER OCCURS FIRST

Change engine oil if operating under heavy load or high ambient temperature
Check engine air cleaner foam pre-cleaner, service if required *
Check engine rotating screen/finger guard, clean if required *
Check foot brake operation
Check operation of safety switches and replace if required
Check tyre pressures, adjust if required
Lubricate stub axles

Check mowing attachment cutter blades, bolts, nuts, disc/s, housing, and guards for wear or damage, replace if required
Check for loose fasteners, tighten if required
Check battery condition, service if required
Check transmission to cutter vee belt and adjust cutter housing level if required
Check and adjust engine to transmission vee belt if required.

*Service more often under dusty conditions, or where air borne debris is present

DATE / / HOURS.....CUSTOMER/DEALER.....

12 MONTHS OR 100 HOURS WHICH EVER OCCURS FIRST

Change engine oil filter
Change engine oil
Check engine spark plug, clean, adjust, or replace if required
If fitted clean engine exhaust spark arrester
Check engine air cleaner foam pre-cleaner, service if required *
Check engine air cleaner cartridge, service if required*
Clean engine cooling system*
Replace in-line fuel filter
Check foot brake operation
Lubricate stub axles
Check for loose fasteners, tighten if required
Check operation of safety switches, service if required

Check tyre pressures, adjust if required
Check steering chain and sprockets or wear, adjust if required
Check mowing attachment cutter blades, bolts, nuts, disc/s, housing, and guards for wear or damage, replace if required
Re-tension rear wheel retaining nut/s
Check battery condition, service if required
Check belts for wear or damage, replace if required
Check and adjust engine to transmission vee belt if required..
Check transmission to cutter vee belt and adjust cutter housing level if required

*Service more often under dusty conditions, or where air borne debris is present

DATE / / HOURS.....DEALER.....

15 MONTHS OR 125 HOURS WHICH EVER OCCURS FIRST

Change engine oil if operating under heavy load or high ambient temperature
Check engine air cleaner foam pre-cleaner, service if required *
Check engine rotating screen/finger guard, clean if required *
Check operation of safety switches and replace if required
Check foot brake operation
Lubricate stub axles
Check tyre pressures, adjust if required

Check battery condition, service if required
Check mowing attachment cutter blades, bolts, nuts, disc/s, housing, and guards for wear or damage, replace if required
Check for loose fasteners, tighten if required
Check transmission to cutter vee belt and adjust cutter housing level if required
Check and adjust engine to transmission vee belt if required..

*Service more often under dusty conditions, or where air borne debris is present

DATE / / HOURS.....CUSTOMER/DEALER.....

18 MONTHS OR 150 HOURS WHICH EVER OCCURS FIRST

Change engine oil
If fitted clean engine exhaust spark arrester
Check engine air cleaner foam pre-cleaner, service if required *
Check engine rotating screen/finger guard, clean if required *
Check engine air inlet console screen, clean if required *
Check foot brake operation
Check operation of safety switches, service if required
Check tyre pressures, adjust if required
Lubricate stub axles
Check steering chain and sprockets or wear, adjust if required

Check mowing attachment cutter blades, bolts, nuts, disc/s, housing, and guards for wear or damage, replace if required
Check belts for wear or damage, replace if required
Check mowing attachment brake pad for wear, replace if required
Check clutch arm action, adjust if required
Check battery condition, service if required
Check for loose fasteners, tighten if required
Check and adjust engine to transmission vee belt if required..
Check transmission to cutter vee belt and adjust cutter housing level if required

*Service more often under dusty conditions, or where air borne debris is present

DATE / / HOURS.....DEALER.....

21 MONTHS OR 175 HOURS WHICH EVER OCCURS FIRST

Change engine oil if operating under heavy load or high ambient temperature
Check engine air cleaner foam pre-cleaner, service if required *
Check engine rotating screen/finger guard, clean if required *
Check foot brake operation
Check operation of safety switches and replace if required
Check tyre pressures, adjust if required
Lubricate stub axles

Check mowing attachment cutter blades, bolts, nuts, disc/s, housing, and guards for wear or damage, replace if required
Check battery condition, service if required
Check for loose fasteners, tighten if required
Check transmission to cutter vee belt and adjust cutter housing level if required
Check and adjust engine to transmission vee belt if required..

*Service more often under dusty conditions, or where air borne debris is present

DATE / / HOURS.....CUSTOMER/DEALER.....

24 MONTHS OR 200 HOURS WHICH EVER OCCURS FIRST

Replace engine oil filter
Change engine oil
Check engine spark plug, clean, adjust, or replace if required
If fitted clean engine exhaust spark arrestor
Check engine air cleaner foam pre-cleaner, service if required *
Check engine air cleaner cartridge, service if required
Clean engine cooling system*
Check foot brake operation
Check operation of safety switches, service if required
Check tyre pressures, adjust if required

Lubricate stub axles
Check steering chain and sprockets for wear, adjust if required
Check mowing attachment cutter blades, bolts, nuts, disc/s, housing, and guards for wear or damage, replace if required
Check belts for wear or damage, replace if required
Check battery condition, service if required
Check for loose fasteners, tighten if required
Check and adjust engine to transmission vee belt if required..
Check transmission to cutter vee belt and adjust cutter housing level if required

*Service more often under dusty conditions, or where air borne debris is present

DATE / / HOURS.....DEALER.....

27 MONTHS OR 225 HOURS WHICH EVER OCCURS FIRST

Change engine oil if operating under heavy load or high ambient temperature
Check engine air cleaner foam pre-cleaner, service if required *
Check engine rotating screen/finger guard, clean if required *
Check foot brake operation
Check operation of safety switches and replace if required
Check tyre pressures, adjust if required
Lubricate stub axles

Check mowing attachment cutter blades, bolts, nuts, disc/s, housing, and guards for wear or damage, replace if required
Check battery condition, service if required
Check for loose fasteners, tighten if required
Check transmission to cutter vee belt and adjust cutter housing level if required
Check and adjust engine to transmission vee belt if required..

*Service more often under dusty conditions, or where air borne debris is present

DATE / / HOURS.....CUSTOMER/DEALER.....

30 MONTHS OR 250 HOURS WHICH EVER OCCURS FIRST

Change engine oil
If fitted clean engine exhaust spark arrestor
Check engine air cleaner foam pre-cleaner, service if required *
Check engine rotating screen/finger guard, clean if required *
Check foot brake operation
Check operation of safety switches, service if required
Check tyre pressures, adjust if required
Lubricate stub axles
Check steering chain and sprockets for wear, adjust if required

Check mowing attachment cutter blades, bolts, nuts, disc/s, housing, and guards for wear or damage, replace if required
Check belts for wear or damage, replace if required
Check battery condition, service if required
Check for loose fasteners, tighten if required
Check and adjust engine to transmission vee belt if required..
Check transmission to cutter vee belt and adjust cutter housing level if required

*Service more often under dusty conditions, or where air borne debris is present

DATE / / HOURS.....DEALER.....

33 MONTHS OR 275 HOURS WHICH EVER OCCURS FIRST

Change engine oil if operating under heavy load or high ambient temperature
Check engine air cleaner foam pre-cleaner, service if required *
Check engine rotating screen/finger guard, clean if required *
Check foot brake operation
Check operation of safety switches and replace if required
Check tyre pressures, adjust if required
Lubricate stub axles

Check mowing attachment cutter blades, bolts, nuts, disc/s, housing, and guards for wear or damage, replace if required
Check battery condition, service if required
Check for loose fasteners, tighten if required
Check transmission to cutter vee belt and adjust cutter housing level if required
Check and adjust engine to transmission vee belt if required..

*Service more often under dusty conditions, or where air borne debris is present

DATE / / HOURS.....CUSTOMER/DEALER.....

36 MONTHS OR 300 HOURS WHICH EVER OCCURS FIRST

Replace engine oil filter
Change engine oil
Check engine spark plug, clean, adjust, or replace if required
If fitted clean engine exhaust spark arrestor
Check engine air cleaner foam pre-cleaner, service if required *
Check engine air cleaner cartridge, service if required
Clean engine cooling system*
Check foot brake operation
Check operation of safety switches, service if required
Check tyre pressures, adjust if required

Lubricate stub axles
Check steering chain and sprockets for wear, adjust if required
Check mowing attachment cutter blades, bolts, nuts, disc/s, housing, and guards for wear or damage, replace if required
Check belts for wear or damage, replace if required
Check battery condition, service if required
Check for loose fasteners, tighten if required
Check and adjust engine to transmission vee belt if required..
Check transmission to cutter vee belt and adjust cutter housing level if required

*Service more often under dusty conditions, or where air borne debris is present

DATE / / HOURS.....DEALER.....

Chassis & Components 13HP HONDA, 16.5HP & 19.5HP B&S ONLY for serial nos before CR9605S S/N 3058, CR9607S S/N 10082, CR9610S S/N 521, CR9611S S/N 986, CR9612S S/N 211

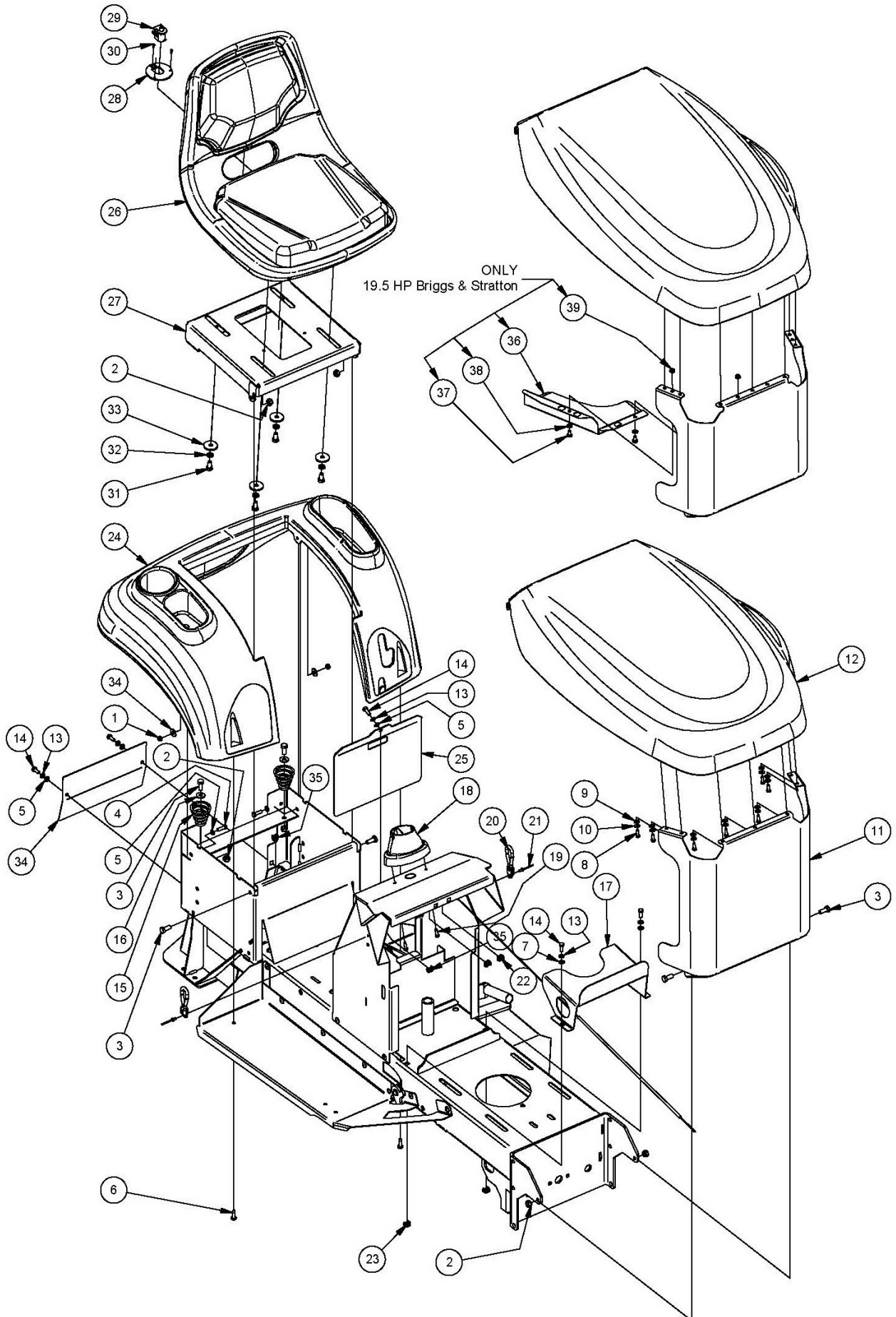

Chassis & Components 13HP HONDA, 16.5HP & 19.5HP B&S ONLY for serial nos before
 CR9605S S/N 3058, CR9607S S/N 10082, CR9610S S/N 521, CR9611S S/N 986, CR9612S S/N 211

ITEM	PART NUMBER	DESCRIPTION	QTY
1	NM6NT	Nut	2
2	NM8NT	Nut	7
3	SH0820M	Screw	6
4	SH0620M	Screw	3
5	W06MN	Washer	5
6	SPPK6X20	Screw, Pan	2
7	W040818	Washer	2
8	SPPK5X16	Screw, Pan	7
9	WSR12	Washer, Seal	7
10	W030820	Washer	7
11	A141173L	Nose, Bonnet 13HP Honda Only	1
	A140073L11M	Nose, Bonnet	1
12	96043	Cowl, Bonnet	1
13	WS040816	Washer, Lock, Spring	5
14	SH0616M	Screw	5
15	13060	Spring, Seat	2
16	W05M202	Washer	2
17	A119214L08L	Stand, Tank, Fuel	1
18	A131009	Cover, Shaft, Steering	1
19	SPPK5X16	Screw, Pan	2
20	96114	Strap, Bonnet	2
21	PR04M4.8	Rivet	2
22	NCM5X2.5X9.5	Nut, Cage	2
23	NCM6X1.6X9.5	Nut, Cage	2
24	96044	Mudguard	1
25	A135021L	Door, Console	1
26	A116109	Sub-Assy, Seat	1
27	A116009L	Mount, Seat, Medium	1
28	90112	Seat Switch Mounting Plate	1
29	SP1PNC5M	Switch, Plunger	1
30	SPST04CX0.37	Screw, Pan	3
31	SH0816M	Screw	4
32	WS050216	Washer, Lock, Spring	4
33	W052003	Washer	4
34	A139036L	Cover, Rear	1
35	NCM6X1.6X9.5	Nut, Cage	3
36	A140075B	Baffle, Hot Air, Bonnet, B&S, 19.5	1
37	SPM6X12	Screw, Pan	2
38	W06MN	Washer	2
39	NM6NT	Nut	2

Chassis & Components 13HP HONDA, 16.5HP & 19.5HP B&S ONLY for serial nos from CR9605S S/N 3058, CR9607S S/N 10082, CR9610S S/N 521, CR9611S S/N 986, CR9612S S/N 211

ITEM	PART NUMBER	DESCRIPTION	QTY
1	NM6NT	Nut	2
2	NM8NT	Nut	6
3	SH0820M	Screw	6
4	SH0620M	Screw	2
5	W06MN	Washer	5
6	SPPK6X20	Screw, Pan	2
7	W040818	Washer	2
8	SPPK5X16	Screw, Pan	7
9	WSR12	Washer, Seal	7
10	W030820	Washer	7
11	A141173L	Nose, Bonnet 13HP Honda Only	1
	A140073L11M	Nose, Bonnet	1
12	96043	Cowl, Bonnet	1
13	WS040816	Washer, Lock, Spring	5
14	SH0616M	Screw	5
15	13060	Spring, Seat	2
16	W05M202	Washer	2
17	A119214L08L	Stand, Tank, Fuel	1
18	A131009	Cover, Shaft, Steering	1
19	SPPK5X16	Screw, Pan	2
20	96114	Strap, Bonnet	2
21	PR04M4.8	Rivet	2
22	NCM5X2.5X9.5	Nut, Cage	2
23	NCM6X1.6X9.5	Nut, Cage	2
24	96044	Mudguard	1
25	A135021L	Door, Console	1
34	A139036L	Cover, Rear	1
35	NCM6X1.6X9.5	Nut, Cage	3
36	A140075B	Baffle, Hot Air, Bonnet, B&S, 19.5	1
37	SPM6X12	Screw, Pan	2
38	W06MN	Washer	2
39	NM6NT	Nut	2
40	A140009L	Mount, Seat	1
41	W0620HD	Washer	4
42	13247	Washer	4
43	WS06081.5	Washer, Lock, Spring	4
44	B0620C	Bolt	4
45	BHSSC0410	Screw, Button	2
46	WS040816	Washer, Lock, Spring	2
47	W040818	Washer	2
48	AM16512F	Switch, Seat	1
48.1	SP1PNCSM	Switch, Plunger	1
49	A140110	Seat	1

Chassis & Components 16HP HONDA ONLY for serial nos before CR9604T S/N 456, CR9606S S/N 2098

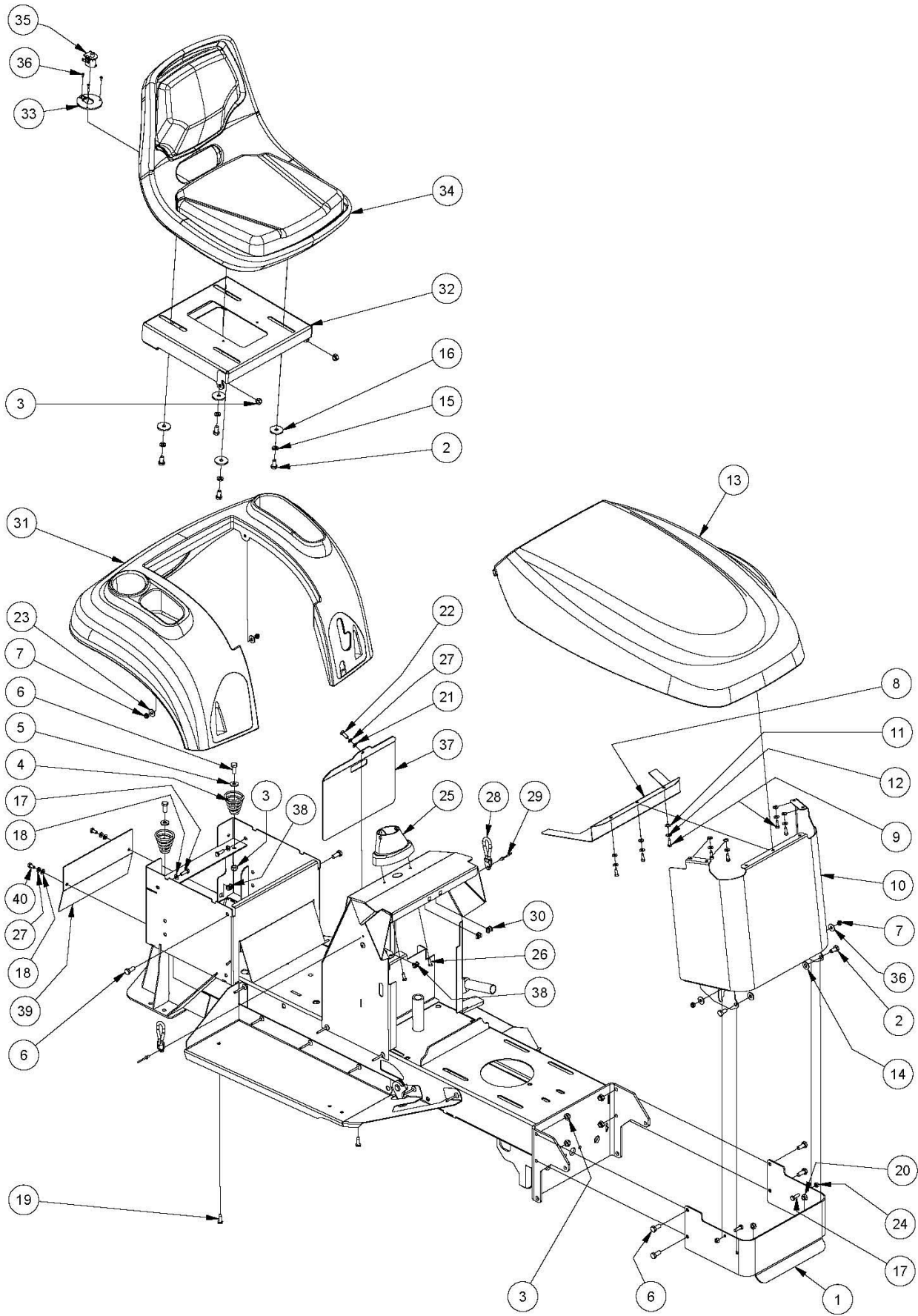

Chassis & Components 16HP HONDA ONLY for serial nos before CR9604T S/N 456, CR9606S S/N 2098

ITEM	PART NUMBER	DESCRIPTION	QTY
1	A141040L	Bumper, Front	1
2	SH0816M	Screw	6
3	NM8NT	Nut	8
4	13060	Spring, Seat	2
5	W05M202	Washer, Flat	2
6	SH0820M	Screw	2
7	NM6NT	Nut	4
8	A119075B	Baffle, Hot Air, Bonnet, Front	1
9	SPPK5X16	Screw, Pan	7
10	A119073L10G	Nose, Bonnet, Sloping	1
11	WSR12	Washer, Seal	7
12	W030820	Washer, Flat	7
13	96043	Cowl, Bonnet	1
14	W051216	Washer, Flat	2
15	WS050216	Washer, Lock, Spring	4
16	W052003	Washer, Flat	4
17	SH0620M	Screw	4
18	W06MN	Washer, Flat	4
19	SPPK6X20	Screw, Pan	2
20	NHCM8	Nut	2
21	W040816	Washer, Flat	1
22	SH0616M	Screw	1
23	W041216	Washer, Flat	4
24	NHM6	Nut	2
25	A131009	Cover, Shaft, Steering	1
26	SPPK5X16	Screw, Pan	2
27	WS040816	Washer, Lock, Spring	3
28	96114	Strap, Bonnet	2
29	PR04M4.8	Rivet	2
30	NCM5X2.5X9.5	Nut, Cage	2
31	96044	Mudguard	1
32	A116009L11D	Mount, Seat, Medium	1
33	90112	Seat Switch Mounting Plate	1
34	A116110	Seat, Medium	1
35	SP1PNCM	Switch, Plunger	1
36	SPST04CX0.37	Screw, Pan	3
37	A135021L	Door, Console	1
38	NCM6X1.6X9.5	Nut, Cage	3
39	A139036L	Cover, Rear	1
40	SH0612M	Screw	2

Chassis & Components 16HP HONDA ONLY for serial nos from CR9604T S/N 456, CR9606S S/N 2098

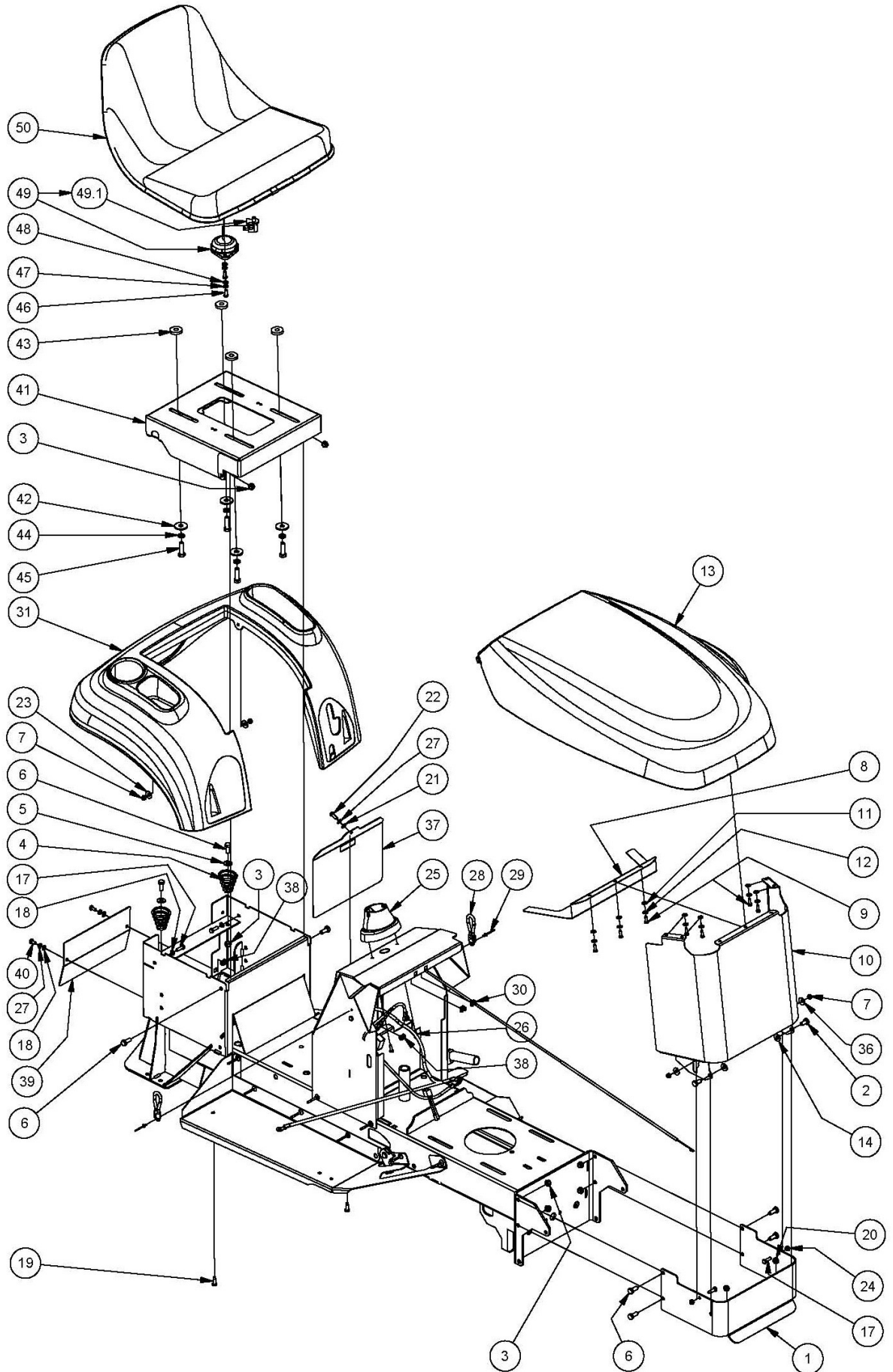

Chassis & Components 16HP HONDA ONLY for serial nos from CR9604T S/N 456, CR9606S S/N 2098

ITEM	PART NUMBER	DESCRIPTION	QTY
1	A141040L	Bumper, Front	1
2	SH0816M	Screw	2
3	NM8NT	Nut	8
4	13060	Spring, Seat	2
5	W05M202	Washer	2
6	SH0820M	Screw	2
7	NM6NT	Nut	4
8	A119075B	Baffle, Hot Air, Bonnet, Front	1
9	SPPK5X16	Screw, Pan	7
10	A119073L10G	Nose, Bonnet, Sloping	1
11	WSR12	Washer, Seal, Epdm Rubber	7
12	W030820	Washer	7
13	96043	Cowl, Bonnet	1
14	W051216	Washer	2
17	SH0620M	Screw	4
18	W06MN	Washer	4
19	SPPK6X20	Screw, Pan	2
20	NHCM8	Nut, Hex, Conelok	2
21	W040816	Washer	1
22	SH0616M	Screw	1
23	W041216	Washer	4
24	NHM6	Nut	2
25	A131009	Cover, Shaft, Steering	1
26	SPPK5X16	Screw, Pan	2
27	WS040816	Washer, Lock, Spring	3
28	96114	Strap, Bonnet	2
29	PR04M4.8	Rivet	2
30	NCM5X2.5X9.5	Nut, Cage	2
31	96044	Mudguard	1
37	A135021L	Door, Console	1
38	NCM6X1.6X9.5	Nut, Cage	3
39	A139036L	Cover, Rear	1
40	SH0612M	Screw	2
41	A140009L	Mount, Seat	1
42	W0620HD	Washer	4
43	13247	Washer	4
44	WS06081.5	Washer, Lock, Spring	4
45	B0620C	Bolt	4
46	BHSSC0410	Screw, Button	2
47	WS040816	Washer, Lock, Spring	2
48	W040818	Washer	2
49	AM16512F	Switch, Seat	1
49.1	SP1PNCM	Switch, Plunger	1
50	A140110	Seat	1

Steering Components

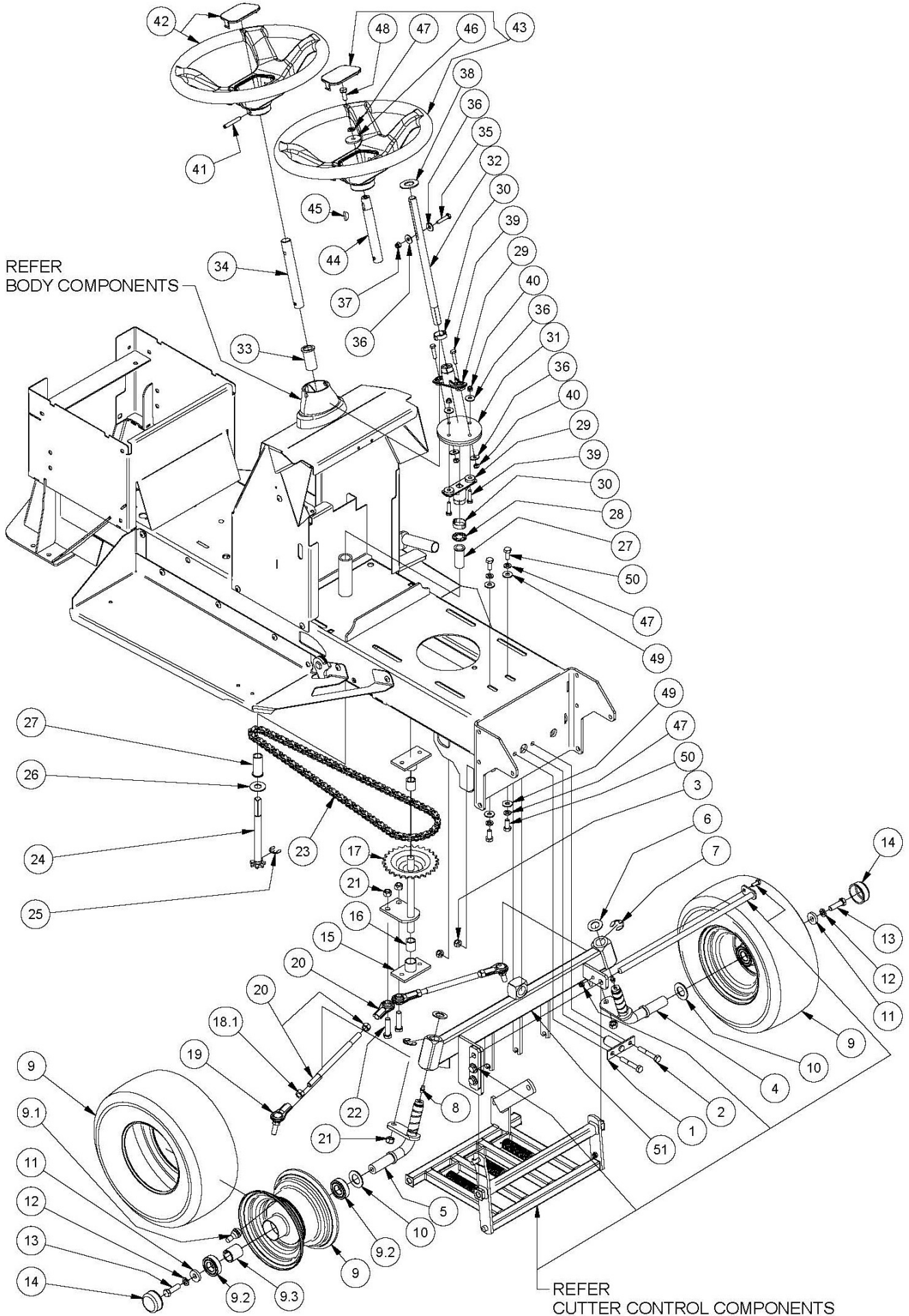

Steering Components

ITEM	PART NUMBER	DESCRIPTION	QTY
1	13242	Pin, Pivot, Front Axle	1
2	B0850M	Bolt	2
3	NM8NT	Nut	4
4	13203	Axle, Stub, Left	1
5	13204	Axle, Stub, Right	1
6	AM336	Washer, Sealing, Shaft	2
7	C02	Circlip	2
8	GNTF3	Nipple, Grease	2
9	A139032	Wheel	2
9.1	VSS	Valve, Tubeless	1
9.2	BB204212N	Bearing, Ball	2
9.3	AM021	Sleeve, Spacer, Bearing	1
10	W20MN	Washer, Flat	2
11	13107	Washer	2
12	WS06081.5	Washer, Lock, Spring	2
13	SH0620F	Screw	2
14	A116060	Cap, Hub	2
15	AM255	Steering Idler Shaft Mtg Brkt	2
16	AM215	Idler Bush	2
17	90271	Idler, Steering	1
18	AM256	Tie Rod Inc. Nuts	2
18.1	N06F	Nut	2
19	RE38INTSTUD	End, Rod	2
20	AM337	End, Rod	2
21	N06FC	Nut	4
22	B0624F	Bolt	2
23	AM018	Chain, Steering	1
24	95006	Shaft, Steering, Lower	1
25	C05	Circlip	1
26	W092016	Washer, Flat	1
27	AM017C1	Steering Shaft Bush With Collar	2
28	89100	Fastener, Pushon	1
29	89097	Steering Shaft Yoke	2
30	OC21	"O" Clip	2
31	AM25399J	Disc, Universal Joint	1
32	A131087Z	Shaft, Steering, Upper	1
33	13012	Bush, Flanged, Nylon	1
34	A131089Z	Shaft, Steering, Top	1
35	B0630M	Bolt	1
36	W041216	Washer, Flat, Bright	6
37	NM6N	Nut	1
38	W122414	Washer, Flat	1
39	B0625M	Bolt	4
40	NM6NT	Nut	6
41	DP10	Pin, Roll	1
42	SW13	Wheel, Steering, 13" Incl Cover	1
43	SW13T	Wheel, Steering, 13", 3/4" Taper Hub+ Cover	1
44	A131109Z	Shaft, Steering, Top, 3/4" Taper	1
45	SK09	Key, Woodruff	1
46	W052003	Washer, Flat	1
47	WS050216	Washer, Lock, Spring	5
48	SH0512F	Screw	1
49	W05M202	Washer, Flat	6
50	SH0512C	Screw	4
51	A139103L	Beam, Axle, Front	1

Drive Components

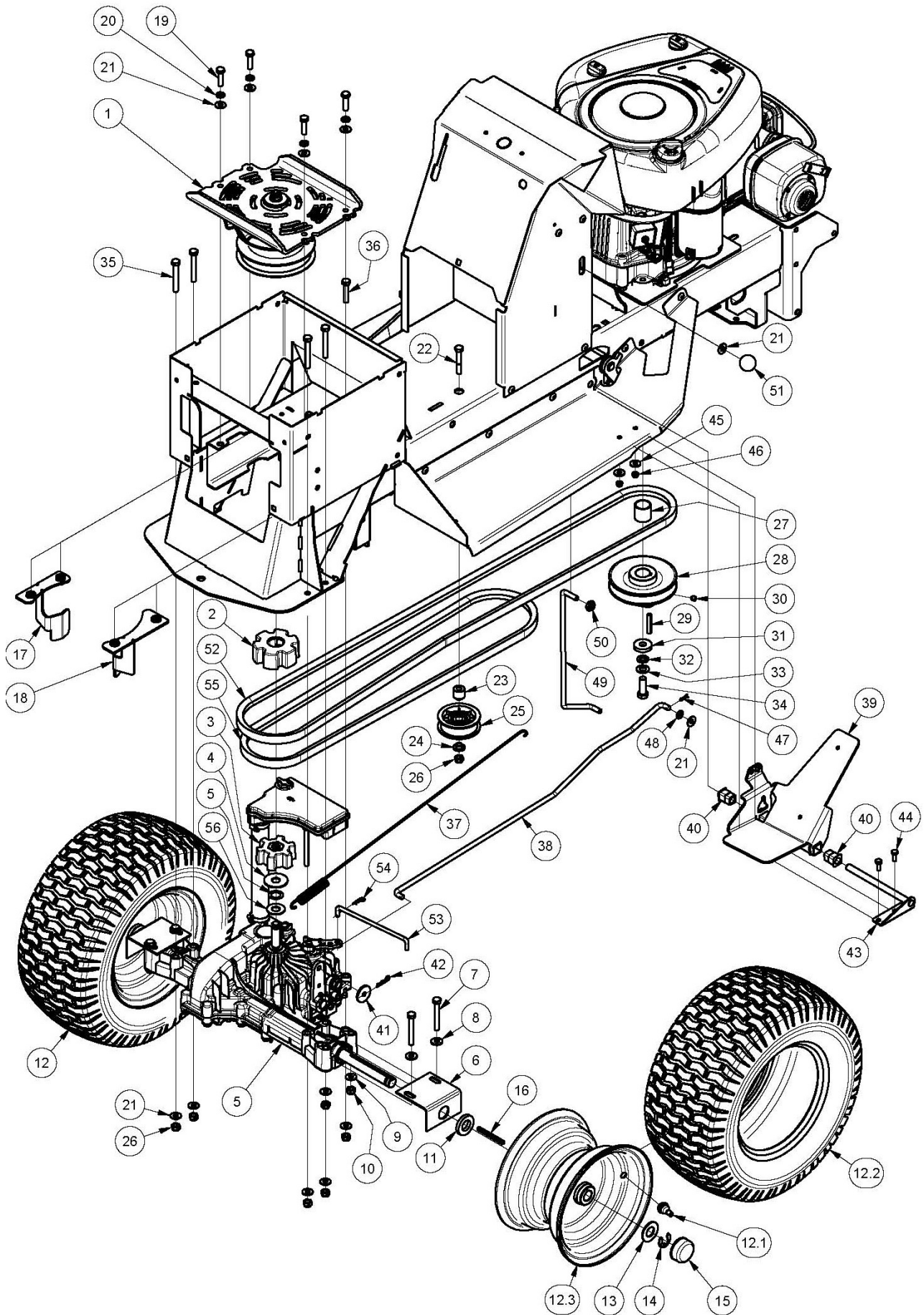

Drive Components

ITEM	PART NUMBER	DESCRIPTION	QTY
1		Sub-Assy, PTO	1
2	A116013	Cushion, Drive	1
3	A116025	Spline, Driven, Cushion, Large	1
4	89048	Washer	1
5	A139012	Transaxle, Hydro	1
6	14022	Bracket, Thrust, Hub	2
7	B0860M	Bolt	4
8	W05M202	Washer	4
9	W051218	Washer	4
10	NM8NT	Nut	4
11	W203806	Washer	2
12	A116139	Wheel	2
12.1	VSS	Valve, Tubeless	1
12.2	TT16X 650-8SS	Tyre, Tubeless	1
13	W122414	Washer	2
14	C02	Circlip	2
15	A116060	Cap, Hub	2
16	14126	Key	2
17	A139092Z	Guide, Belt, Left	1
18	A139094Z	Guide, Belt, Right	1
19	B0830M	Bolt	4
20	WS050216	Washer, Lock, Spring	4
21	W051218	Washer	11
22	B0850M	Bolt	1
23	90293	Boss, Idler	1
24	90294	Boss, Idler	1
25	PIFBB126598A	Idler, Flat	1
26	NM8NT	Nut	6
27	A108103	Spacer, Pulley, Engine	1
28	A108101	Pulley, Engine	1
29	A108104	Key	1
30	GS0505C	Screw, Set	1
31	W072004	Washer	1
32	WS071006	Washer, Lock, Spring	1
33	W071416	Washer	1
34	SH0720F	Bolt	1
35	B0860M	Bolt	4
36	B0840M	Bolt	1
37	A111018	Spring, Extension	1
38	89052	Control Rod	1
39	A111013L	Pedal, Drive	1
40	AM230	Bush - Plastic	2
41	W052003	Washer	1
42	RP01	Pin, 'R'	1
43	A116015Z	Pivot, Pedal, Drive	1
44	SH0616M	Screw	2
45	W041216	Washer, Flat	2
46	NM6NT	Nut	2
47	CP2-512	Pin, Split	1
48	14157	Fastener, Push On, Round	1
49	A111017Z	Pin, Locking, Brake+Drive	1
50	A111050Z	Bush, Pin, Locking	1
51	14038	Knob	1
52	V55	Belt V	1
53	96051	Rod, Select Free Wheel	1
54	RP04	Pin, 'R'	1
55	V13	Belt, V (32" cut only)	1
56	W092016	Washer	1

Drive PTO Components

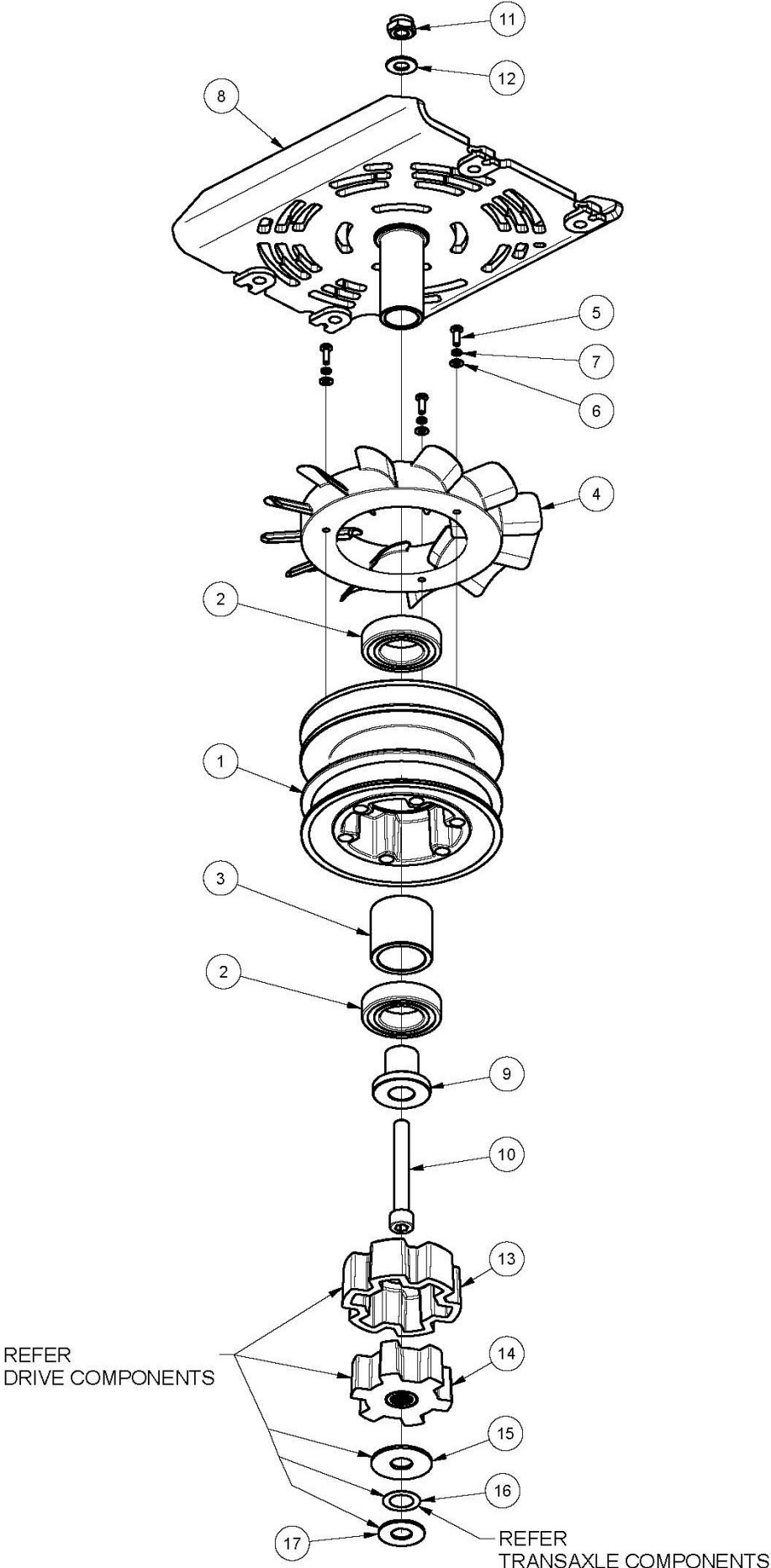

Drive PTO Components

ITEM	PART NUMBER	DESCRIPTION	QTY
1	A139024	Pulley, PTO, Socket, Cushion	1
2	BB305513NS	Bearing, Ball	2
3	A139031	Sleeve, Spacer, Bearing	1
4	A139025	Fan, Transaxle	1
5	SPM4X12	Screw, Pan	3
6	W04MN	Washer, Flat	3
7	WSM4X1.2X1.2	Washer, Lock, Spring	3
8	A139026L	Mount, PTO, Vented	1
9	A139028Z	Retainer, Recessed, Bearing	1
10	CHSBM10X75	Bolt, Cap	1
11	NM10NT	Nut	1
12	W10MN	Washer, Flat	1
13	A116013	Cushion, Drive	1
14	A116025	Spline, Driven, Cushion, Large	1
15	89048	Washer	1
16	T1A646083060	Washer, Wave	1
17	W092016	Washer	1

Transaxle Components

K46AY
Rev. 8-10-04

200 - Seal Kit
201 - Repair Kit

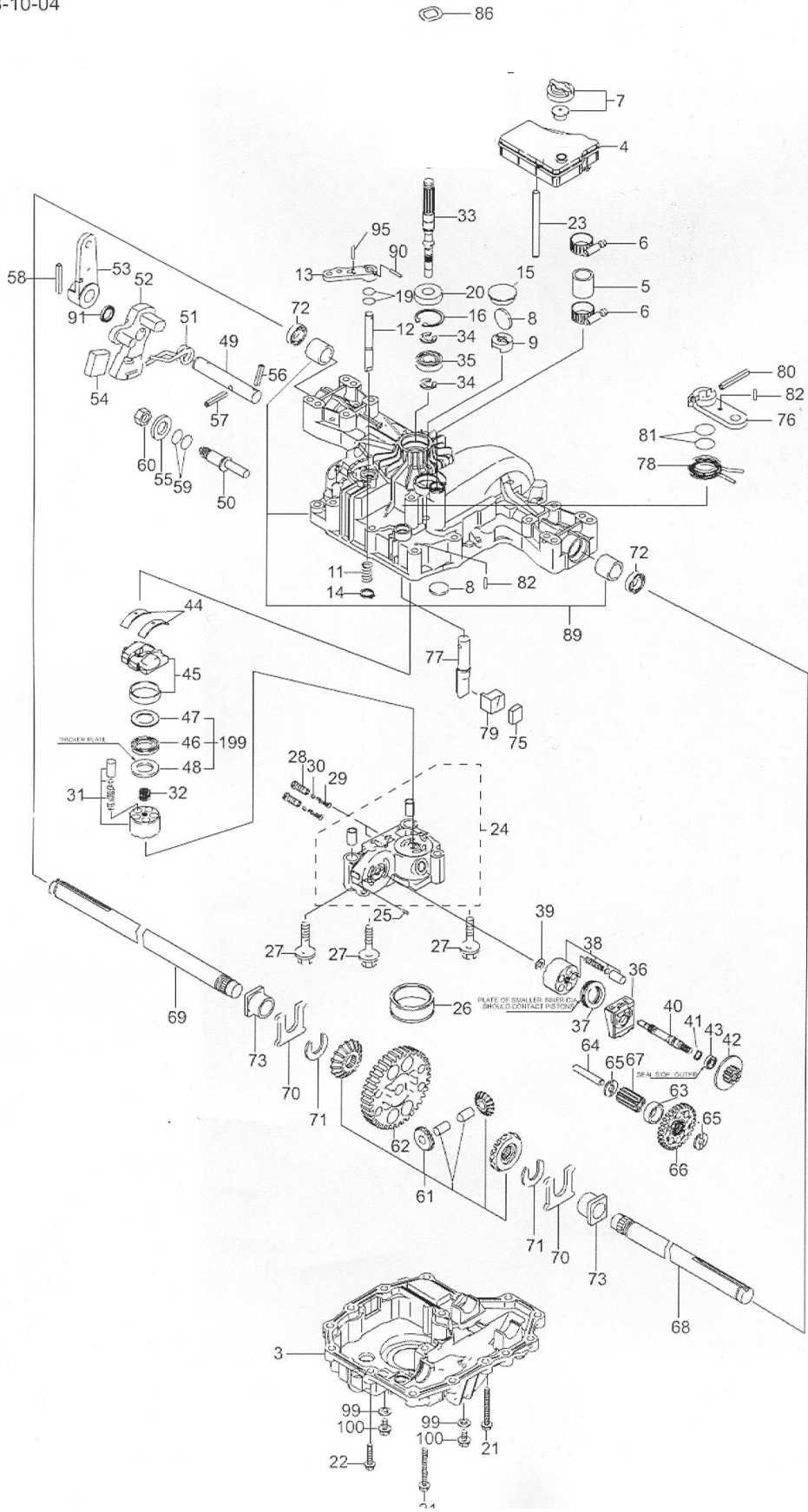

Transaxle Components (TUFF TORQ)

ITEM	PART NO.	DESCRIPTION	QTY	ITEM	PART NO.	DESCRIPTION	QTY
1	A139012	Transaxle	1	58	T22351060040	Roll Pin 6 * 40	1
3	T1A646084163	Lower Case	1	60	T26776120002	Nut 12	1
4	T1A646024460	Reservoir Tank	1	61	T1A646031510	Differential Gear Kit	1
5	KIT232	Hose incl Clamp	1	62	T1A646033520	Final Gear (54t)	1
6	CH12	Clamp	2	63	T1A646033250	Final Pinion Collar	1
7	T19485924252	Vent Valve 15	1	64	T1A646033410	Reduction Shaft	1
9	T1A646024370	Magnet Holder	1	65	T19216833420	Washer 12 * 32 * 3.2	1
11	T19215427281	Spring 25	1	66	T1A646083450	Reduction Gear 31t	1
12	T1A646089510	Bypass Shaft B	1	67	T1A646033531	Final Pinion Gear (10t)	1
13	T1A632029520	Bypass Lever	1	68	T1A646089430	Axle Shaft Left	1
14	T19216829570	Ring 10	1	69	T1A646089440	Axle Shaft Right	1
15	T1C655036300	Sealing Cap 30	1	70	T19216334261	Thrust Washer	1
16	T22252000350	Snap Ring C 35	1	71	T19216834270	Ring 17	1
21	T26476080552	Tapping Screw 8 * 55	1	73	T19216834350	Bushing	1
22	T26476080302	Tapping Screw 8 * 30	1	75	T1A646036121	Brake Shoe	1
23	T1A646024480	Tank Support	1	76	T1A646036160	Brake Lever	1
24	T1A646024910	Center Case K	1	77	T1A646036171	Brake Shaft	1
25	T19216824760	Pin 3 * 9.8	1	78	T1A646036180	Brake Return Spring	1
26	T19216324950	Filter	1	79	T1A646036200	Brake Actuator	1
27	T26106100752	Bolt 10 * 75	1	80	T22351050032	Pin 5 * 32	1
28	T1A646024800	Ids Valve	1	82	T22351040016	Spring Pin 4 * 16	1
29	T1A646024761	Ids Spring	1	86	T1A646083060	Wave Washer	1
30	T1A646024790	Ids Filter 300	1	89	T1A646024302	Upper Case Kit	1
31	T19216825111	Cylinder Block Kit	1	90	T22351030020	Pin 3.0a * 20	1
32	T1A646025200	Spring	1	95	T22351030016	Spring Pin 3.0a * 16	1
33	T1A646025251	Pump Shaft	1	100	T26106080122	Drain Bolt 8 * 12	1
35	T24101062020	Bearing 6202c3	1	199	T1A646088150	Bearing	1
36	T19216824210	Motor Housing	1	200	T1A646099140	K46 Seal Kit (All Models)	1
37	T19216324240	Thrust Bearing 51106	1	201	T46005	Repair Kit	1
38	T19216825210	Cylinder Block Kit	1				
39	T19216825230	Washer 12 * 24 * 1	1				
40	T1A646025271	Motor Shaft	1				
41	T19215425310	Snap Ring S15	1				
42	T1A646085400	Motor Gear 12t	1				
43	T24102062020	Bearing 6202 Duc3	1				
44	T19216327060	Thrust Metal	1				
45	T1A646024700	Swash Plate	1				
49	T1A646029911	Control Shaft	1				
50	T1A646029920	Fulcrum	1				
51	T1A646029800	Torsion Spring, Standard	1				
52	T1A646029900	Control Arm E	1				
53	T1A646029851	Control Lever C	1				
54	T1A646029350	Jerky Plate	1				
55	T22137120000	Washer 12	1				
56	T1A646029940	Cotter Pin 1/8" * 3/4"	1				
57	T22351060036	Spring Pin 6 * 36	1				

Engine Ancillary Components B&S ONLY

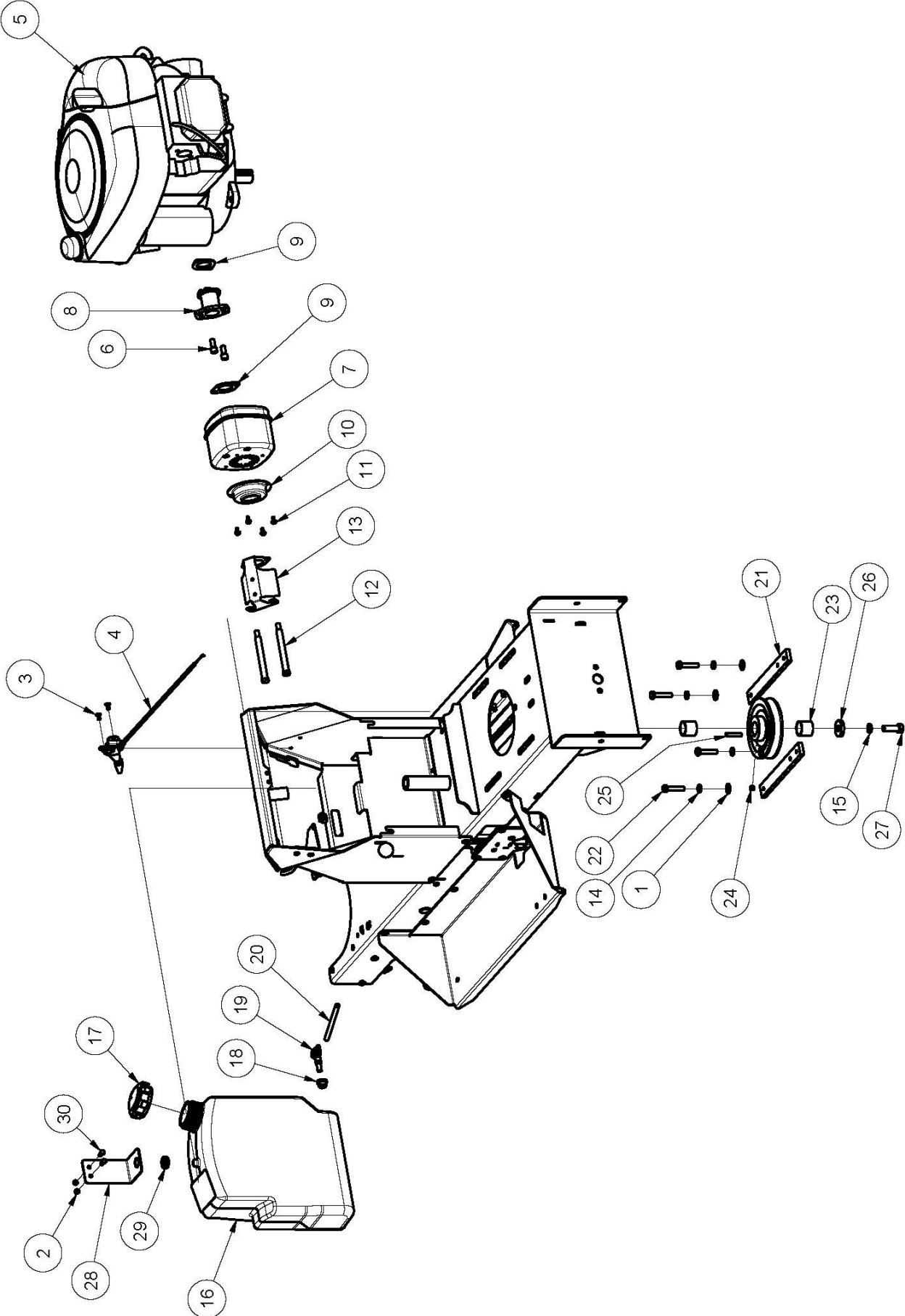

Engine Ancillary Components B&S ONLY

ITEM	PART NUMBER	DESCRIPTION	QTY
1	W051218	Washer, Flat	4
2	NM5NT	Nut	2
3	BHSSM5X12	Screw, Control, Throttle	2
	NM5NT	Nut, Control, Throttle	2
4	A131101	Assy, Control, Throttle	1
5		Engine	1
	A108109B09H	Engine Plate	1
6	CHSS0512C	Screw, Cap	2
7		Side muffler	1
8		Side muffler manifold	1
9		Gasket B&S	2
10		Side muffler deflector	1
11	ST0806	Screw	4
12		Side muffler screw	2
13		Side muffler bracket	1
14	WS050216	Washer, Lock, Spring	4
15	WS071008	Washer, Lock, Spring	1
16	80033	Tank, Fuel	1
17	CF01	Cap, Fuel	1
18	AM294	Grommet, Fuel Tap	1
19	AM293	Fuel Tap	1
20	14107	Fuel Hose	1
21	AM078B0	Mount, Plate	2
22	B0524C	Bolt	4
23	A108103	Engine Pulley Spacer	2
24	GS0505C	Screw, Set	1
	KIT204	Engine Pulley Kit (incl pulley, spacer, key & screw)	1
25	A108104	Key, Engine Pulley	1
26	W072004	Washer, Flat	1
27	SH0724F	Bolt	1
	W071416	Washer, Flat	2
28	A105007B	Bracket. Restrain, Fuel Tank	1
29	80037	Grommet	1
30	SPM5x12	Screw	2
	AM295	Spark Plug Spanner	1

Engine Ancillary Components 13HP Honda ONLY

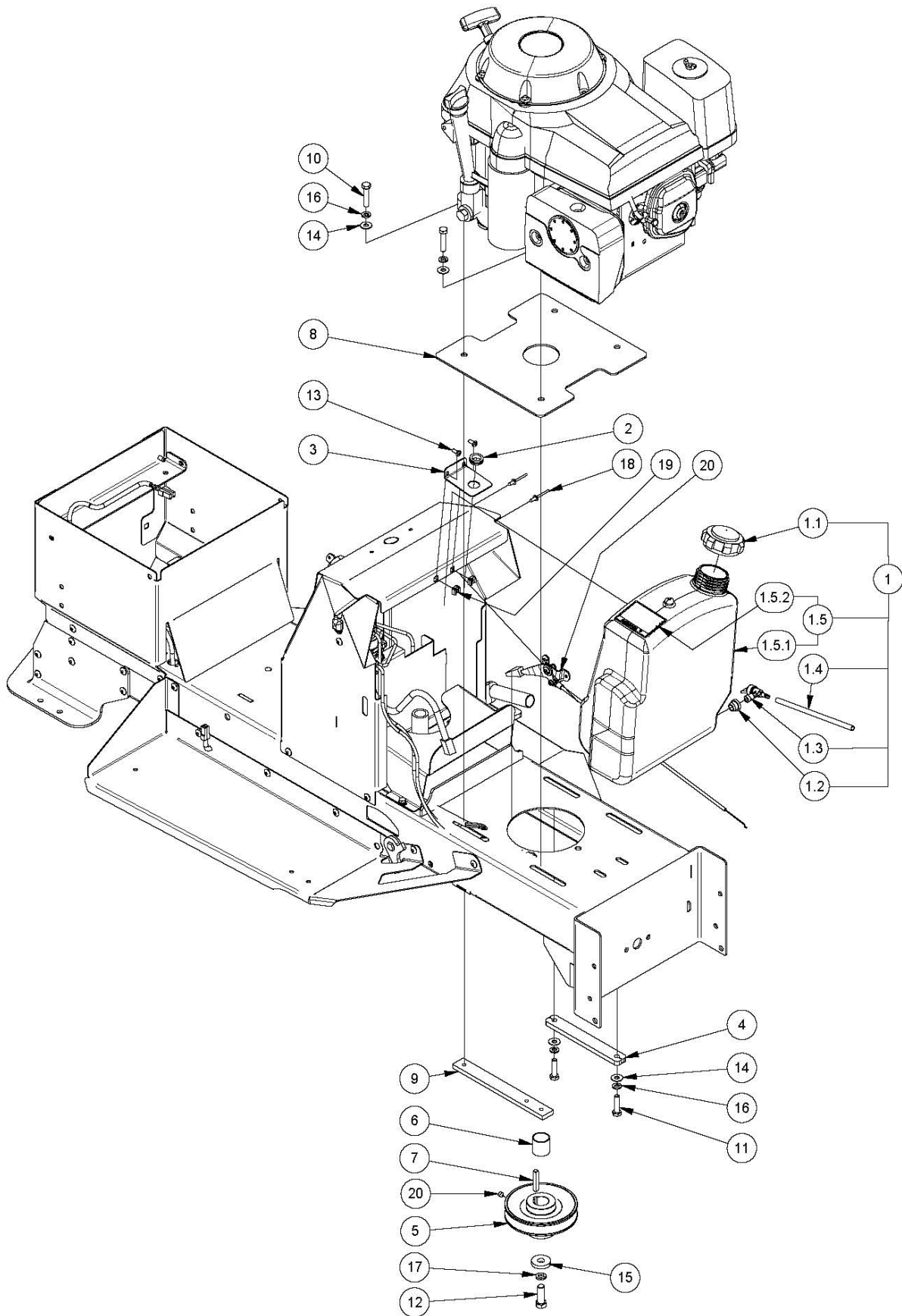

Engine Ancillary Components 13HP Honda ONLY

ITEM	PART NUMBER	DESCRIPTION	QTY
1	80035	Sub-Assy, Tank, Fuel	1
1.1	CF01	Cap, Fuel	1
1.2	AM294	Grommet, Fuel Tap	1
1.3	AM293	Petrol Tap	1
1.4	14107	Line, Fuel, L=180	1
1.5	KIT167	Kit, Tank, Fuel	1
1.5.1		Tank, Fuel	1
1.5.2		Decal, Warning, Fuel	1
2	80037	Grommet	1
3	A107007B	Bracket, Restrain, Fuel Tank	1
4	A107114Z	Plate, Mount, Engine, 13.0 Hon, Left	1
5	A108101	Pulley, Engine	1
6	A108103	Spacer, Pulley, Engine, L=28	1
7	A108104	Key	1
8	A108109B09H	Plate, Base, Engine	1
	CP07	Clip	1
	BHSSM5X12	Screw	1
	NM5N	Nut	1
9	AM078B0	Engine Mount Bolt Plate	1
10	B0524C	Bolt	2
11	B0520F	Bolt	2
12	SH0724F	Bolt	1
	W071416	Washer, Flat	2
13	SPM5X12	Screw, Pan	2
14	W051218	Washer, Flat	4
15	W072004	Washer, Flat	1
16	WS050216	Washer, Lock, Spring	4
17	WS071008	Washer, Lock, Spring	1
18	PR0306	Rivet	2
19	NCM5X2.5X9.5	Nut, Cage	2
20	A133033	Control, Speed, Engine, 13.0HP	1

Engine Ancillary Components 16HP HONDA ONLY

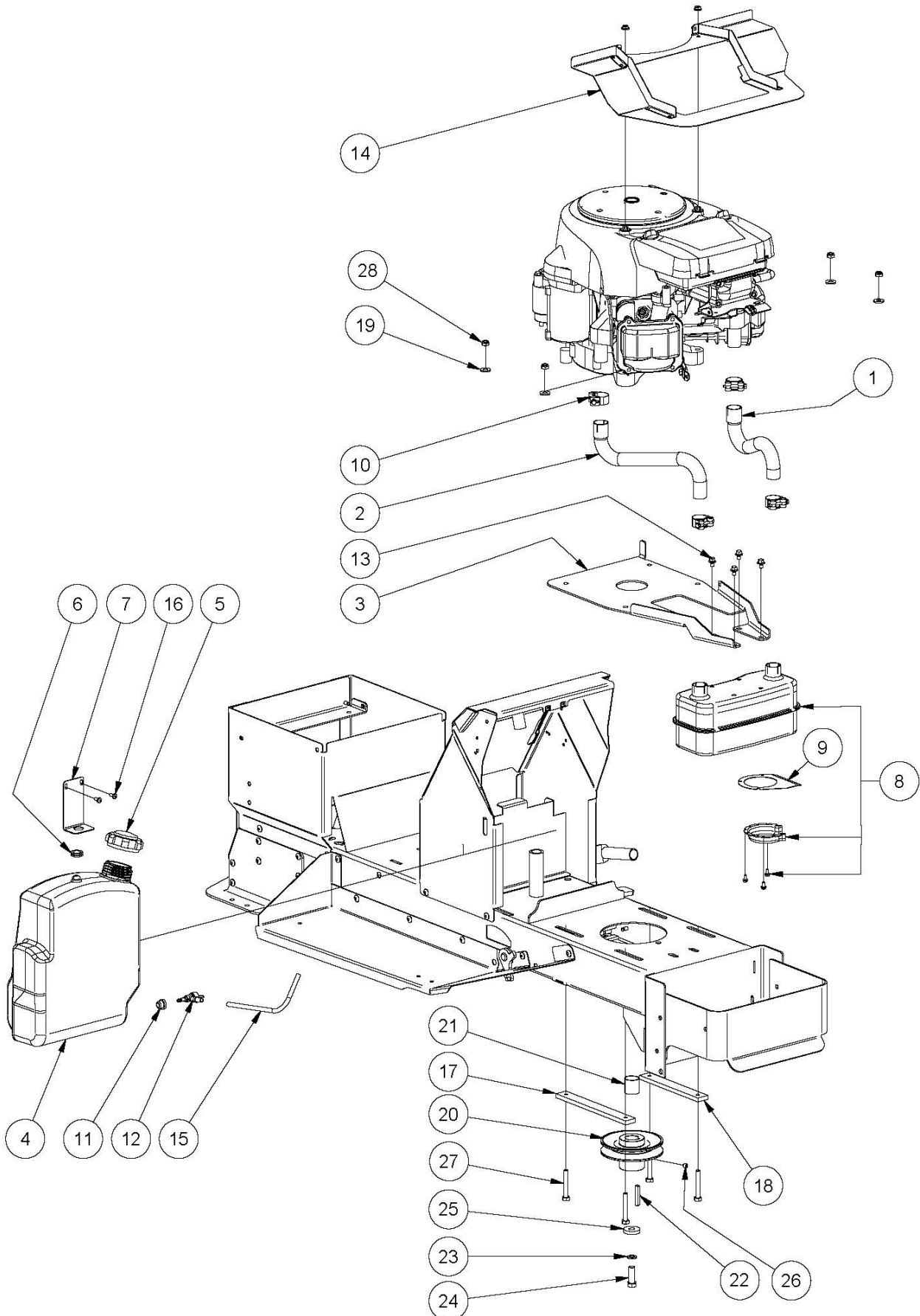

Engine Ancillary Components 16HP HONDA ONLY

ITEM	PART NUMBER	DESCRIPTION	QTY
1	A119121C	Pipe, Exhaust, Left	1
2	A119123C	Pipe, Exhaust, Right	1
3	A119125Z	Bracket, Muffler, 16.0 Hon	1
4	80033	Tank, Fuel	1
5	CF01	Cap, Fuel	1
6	80037	Grommet	1
7	A105007B	Bracket, Restrain, Fuel Tank	1
8	90167	Muffler, Exhaust	1
9	80025	Deflector, Exhaust Gas	1
10	90168	Clamp, Hose, T-Bolt	4
11	AM294	Grommet	1
12	AM293	Petrol Tap	1
13	B0408TFS	Screw	4
14	A119127B09G	Baffle, Hot Air, Engine, Front	1
15	A119129	Fuel Line	1
16	SPM5X12	Screw, Pan	2
17	A116208Z	Plate, Mounting, Engine, Right	1
18	A116207Z	Plate, Mounting, Engine, Left	1
19	W05M202	Washer	4
20	A108101	Pulley, Engine	1
21	A108103	Spacer, Pulley, Engine	1
22	A108104	Key	1
23	WS071008	Washer, Lock, Spring	1
24	SH0724F	Bolt	1
	W071416	Washer, Flat	2
25	W072004	Washer	1
26	GS0505C	Screw, Set	1
27	SH0850M	Screw	4
28	NHCM8	Nut	4
	A133133	Control, Speed, Engine	1
	BHSSM5X12	Screw, Control, Throttle	2
	NM5NT	Nut, Control, Throttle	2
	A119135	Clamp, Cable	1
	NM8NT	Nut	1
	SH0616M	Screw	1
	W041216	Washer	1
	AM295	Spark Plug Spanner	1
	AM005G0	Spark Plug Spanner 16HP Honda Only	1

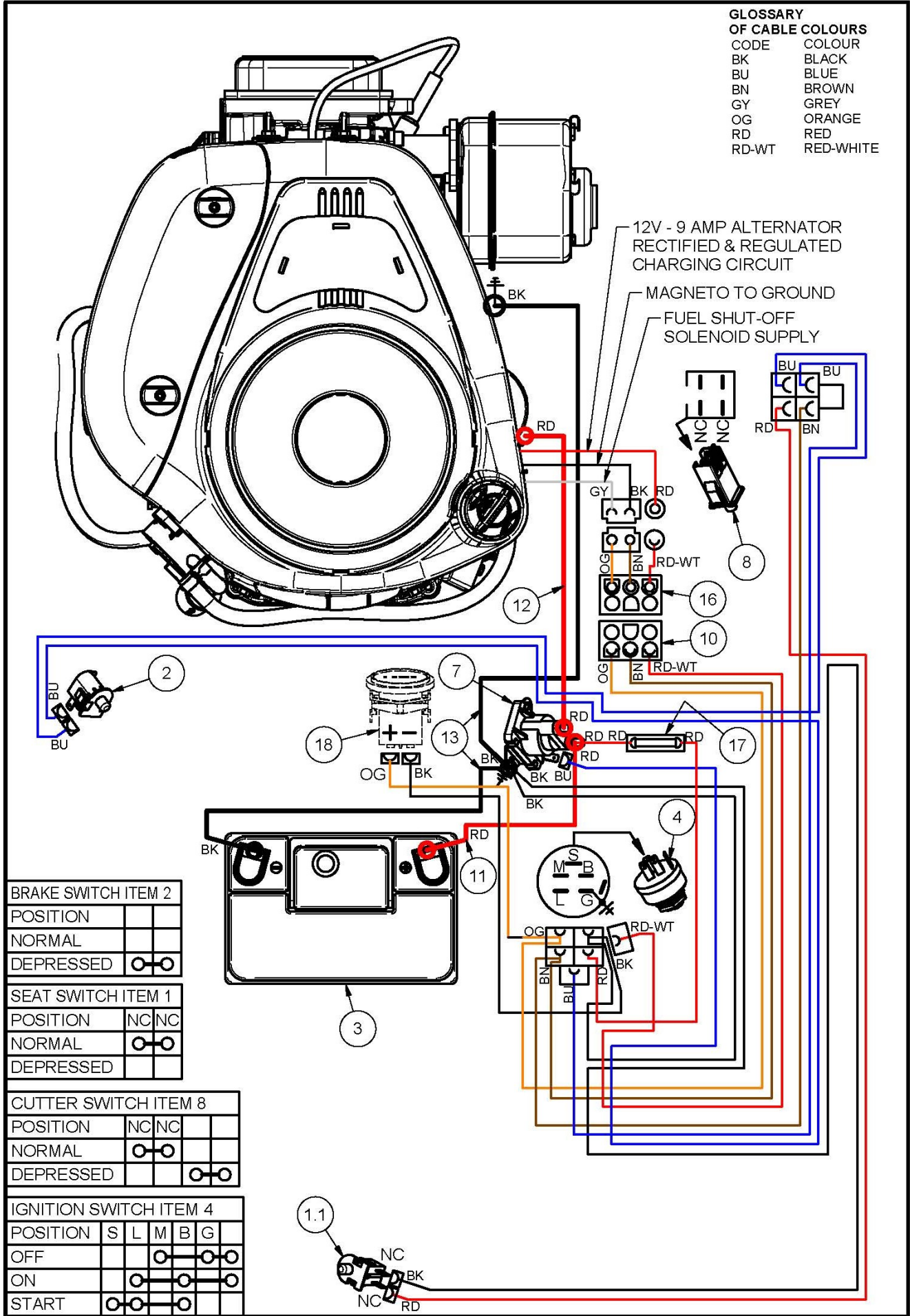

BRAKE SWITCH ITEM 2

POSITION		
NORMAL		
DEPRESSED		

SEAT SWITCH ITEM 1

POSITION	NC	NC
NORMAL		
DEPRESSED		

CUTTER SWITCH ITEM 8

POSITION	NC	NC		
NORMAL				
DEPRESSED				

IGNITION SWITCH ITEM 4

POSITION	S	L	M	B	G
OFF					
ON					
START					

Electrical Components Schematic 16.5HP & 19.5HP B&S Only

ITEM	PART NUMBER	DESCRIPTION	QTY
		Engine, B&S	1
1	AM16512F	Switch, Seat	1
1.1	SP1PNCSM	Switch, Plunger	1
2	SKIT132	Switch, Plunger , Inc Cover	1
3		Battery, Automotive, 12V, CMFU1, 9PL, 240CCA	1
4	13125	Switch, Key	1
5	AM015	Pair, Key, Ignition	1
6	SH0616M	Screw	2
7	AM159	Solenoid, Starter	1
	NM6NT	Nut	2
	SH0620M	Screw	2
8	SKIT133	Switch, Plunger, Inc Cover	1
9	NHM6	Nut	2
10	A143026	Harness, Wiring, Main	1
11	89082	Lead, Battery, Red, L= 295	1
12	AM265	Lead, Battery, Red, L= 490	1
13	15235	Lead, Battery, Black, 3term	1
14	N04C	Nut	2
15	W040818	Washer	2
16	A143112	Harness, Wiring, Engine, B&S	1
17		Fuse, Glass, 3ag, 15 Amp	1
18	AM211	Hour Meter, Optional	1

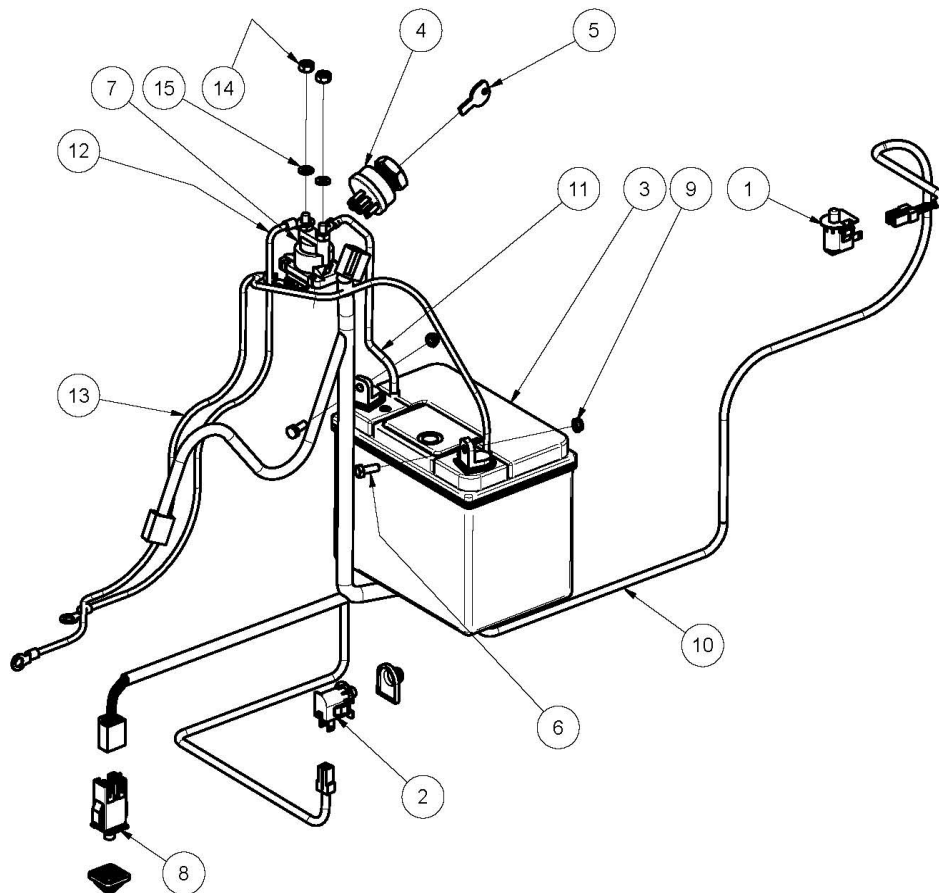

WIRING DIAGRAM - A14111M, LAWN BOSS, HONDA 13.0 HP ENGINE NEW CONNECTOR

GLOSSARY OF CABLE COLOURS

CODE	COLOUR
BK	BLACK
BU	BLUE
BN	BROWN
GY	GREY
OG	ORANGE
RD	RED
RD-WT	RED-WHITE

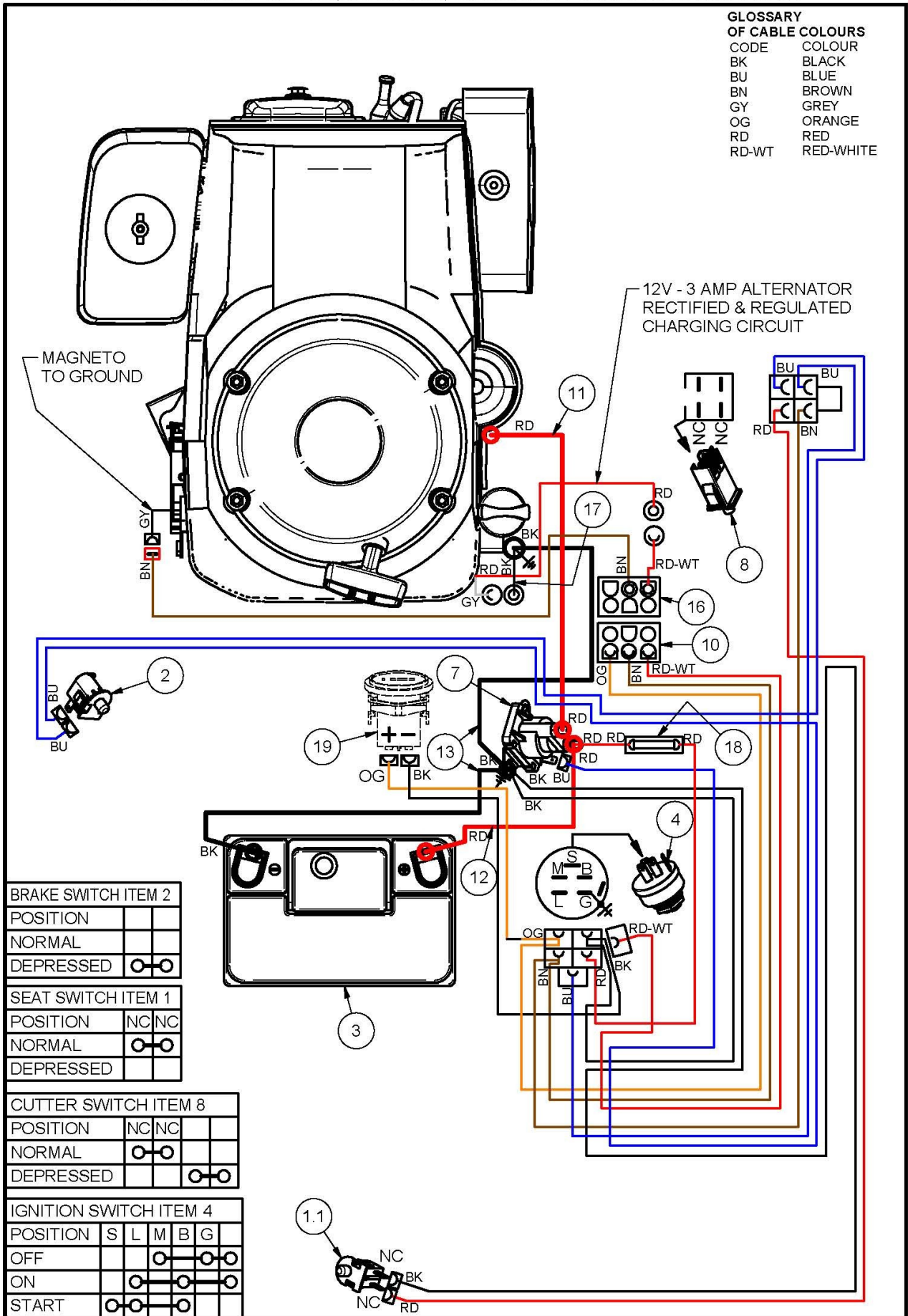

BRAKE SWITCH ITEM 2	
POSITION	
NORMAL	
DEPRESSED	

SEAT SWITCH ITEM 1	
POSITION	NC NC
NORMAL	
DEPRESSED	

CUTTER SWITCH ITEM 8	
POSITION	NC NC
NORMAL	
DEPRESSED	

IGNITION SWITCH ITEM 4	
POSITION	S L M B G
OFF	
ON	
START	

Electrical Components Schematic 13HP HONDA Only

ITEM	PART NUMBER	DESCRIPTION	QTY
		Engine, Honda, 13.0 Hp	
1	AM16512F	Switch, Seat	1
1.1	SP1PNC5M	Switch, Plunger	1
2	SKIT132	Switch, Plunger , Inc Cover	1
3		Battery, Automotive, 12V, CMFU1, 9PL, 240CCA	1
4	13125	Switch, Key	1
5	AM015	Pair, Key, Ignition	1
6	SH0620M	Screw	2
7	AM159	Solenoid	1
	NM6NT	Nut	2
	SH0616M	Screw	2
8	SKIT133	Switch, Plunger , Inc Cover	1
9	NHM6	Nut	2
10	A143026	Harness, Wiring, Main	1
11	89082	Lead, Battery, Red, L= 295	1
12	AM265	Lead, Battery, Red, L= 490	1
13	15235	Lead, Battery, Black, 3term	1
14	N04C	Nut	2
15	W040818	Washer	2
16	A143111	Harness, Wiring, Engine, Hon, 13.0 Hp	1
17	13149	Lead, Earth, Fuel Pump	1
18		Fuse, Glass, 3ag, 15 Amp	1
19	AM211	Hour Meter, Optional	

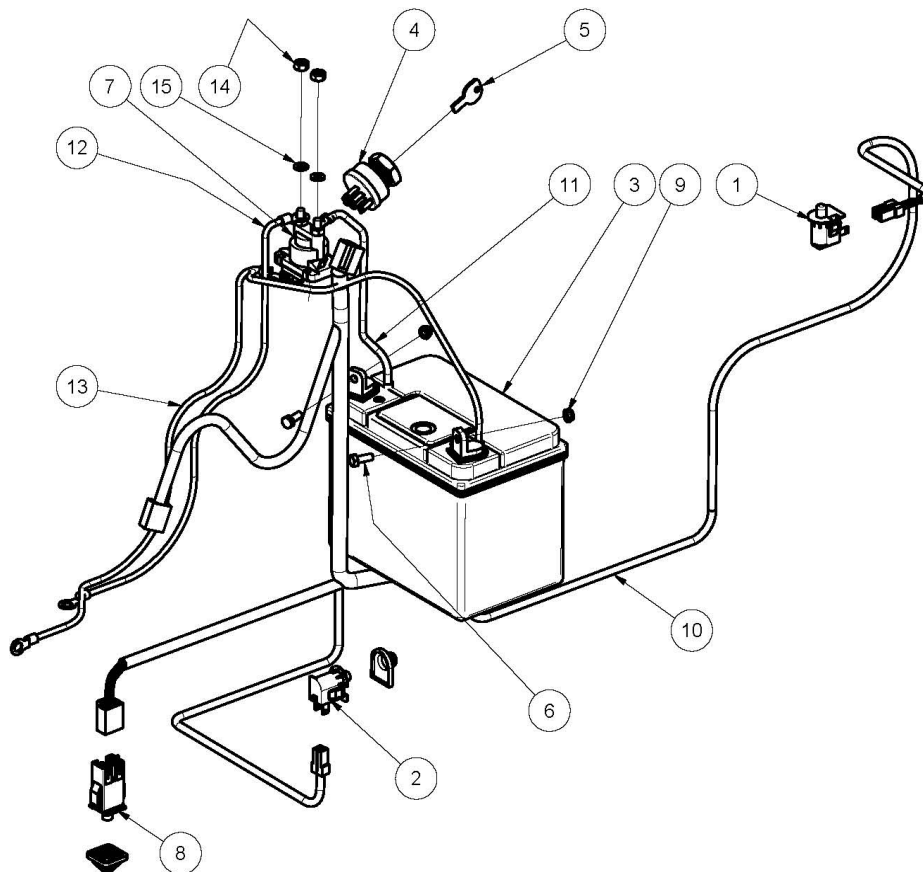

WIRING DIAGRAM - A14111M, LAWN BOSS, HONDA 16.0 HP ENGINE NEW CONNECTOR

GLOSSARY OF CABLE COLOURS

CODE	COLOUR
BK	BLACK
BK-RD	BLACK-RED
BK-WT	BLACK-WHITE
BU	BLUE
BU-WT	BLUE-WHITE
BN	BROWN
GY	GREY
OG	ORANGE
RD	RED
RD-WT	RED-WHITE
WT	WHITE
WT-BU	WHITE-BLUE

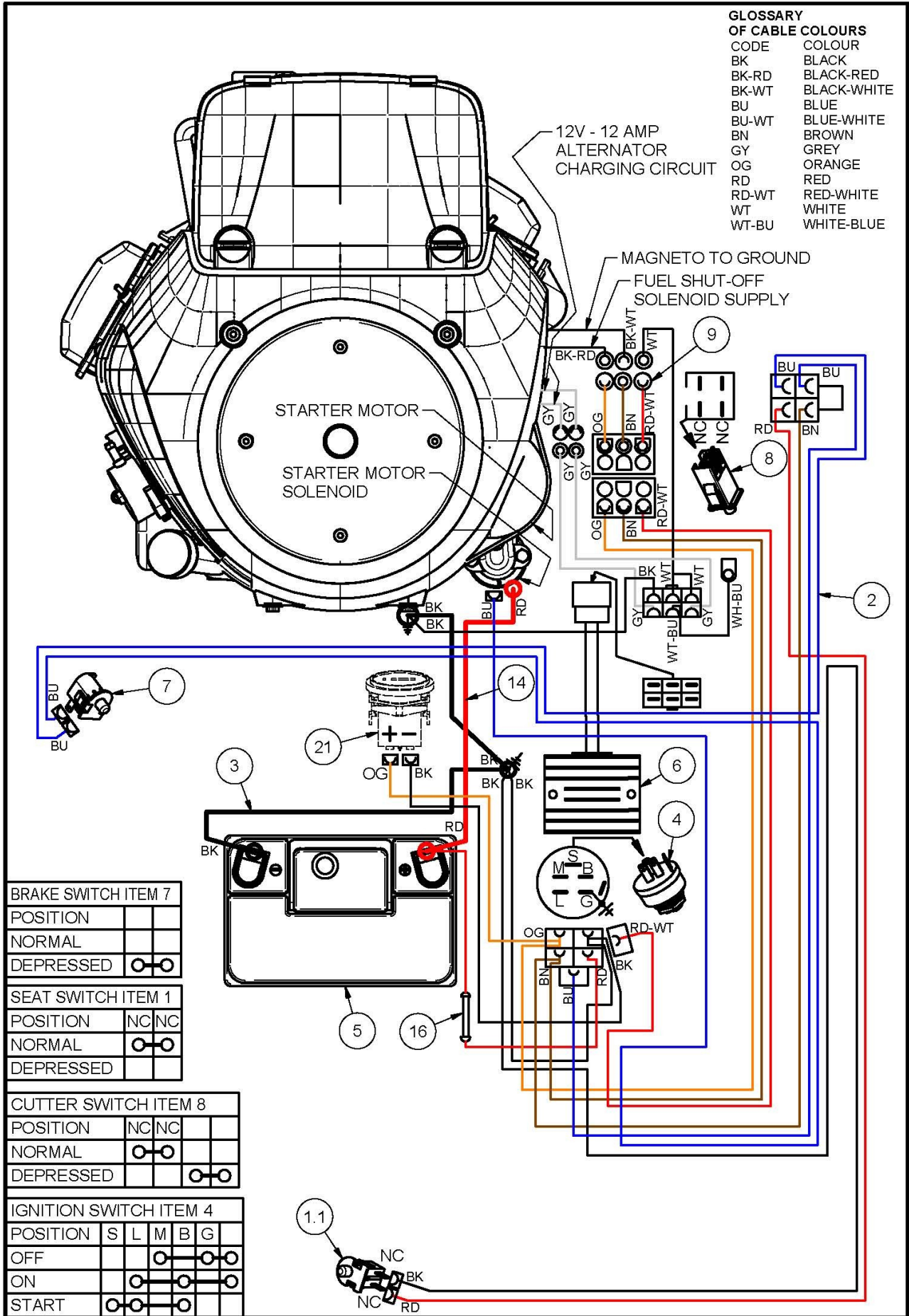

Electrical Components Schematic 16HP HONDA Only

ITEM	PART NUMBER	DESCRIPTION	QTY
		Engine, 16.0hp, V2cyl, Elec, Hon, GXV530	
1	AM16512F	Switch, Seat	1
1.1	SP1PNC5M	Switch, Plunger	1
2	A143026	Harness, Wiring, Main	1
3	13369	Lead, Battery, Black, 3term	1
4	13125	Switch, Key	1
5		Battery, Automotive, 12V, CMFU1, 9PL, 240CCA	1
6		Regulator/Rectifier, Honda	1
7	SKIT132	Switch, Plunger, Inc Cover	1
8	SKIT133	Switch, Plunger, Inc Cover	1
9	A143113	Harness, Wiring, Engine, Hon, 16.0 Hp	1
10	AM015	Pair, Key, Ignition	1
14	84132	Lead, Battery, Red	1
16		Fuse, Glass, 3 Ag, 15 Amp	1
17	NHM8	Nut	2
18	B0635M	Bolt	2
19	NHM6	Nut	2
	NM6NT	Nut	2
20	SH0616M	Screw	2
21	AM211	Hour Meter, Optional	

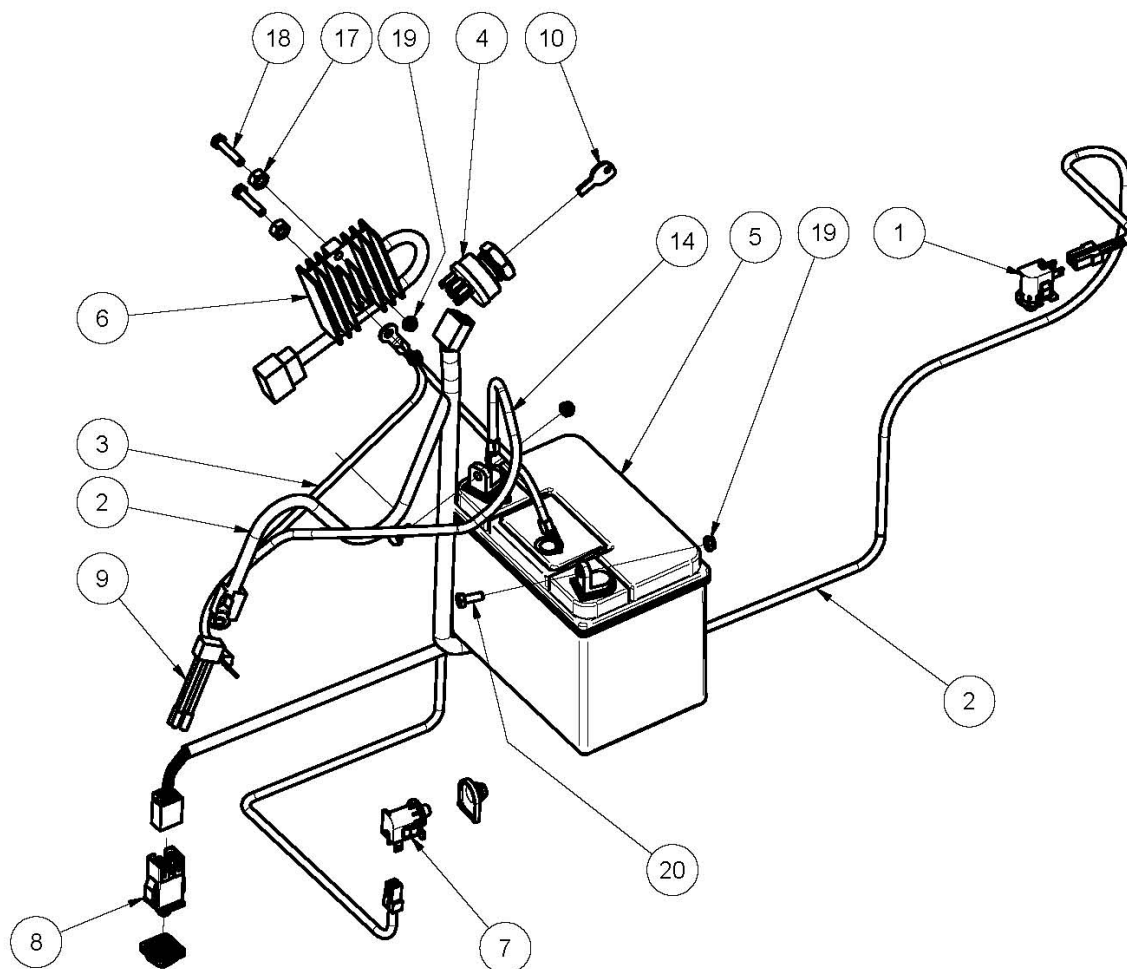

Cutter Control Components

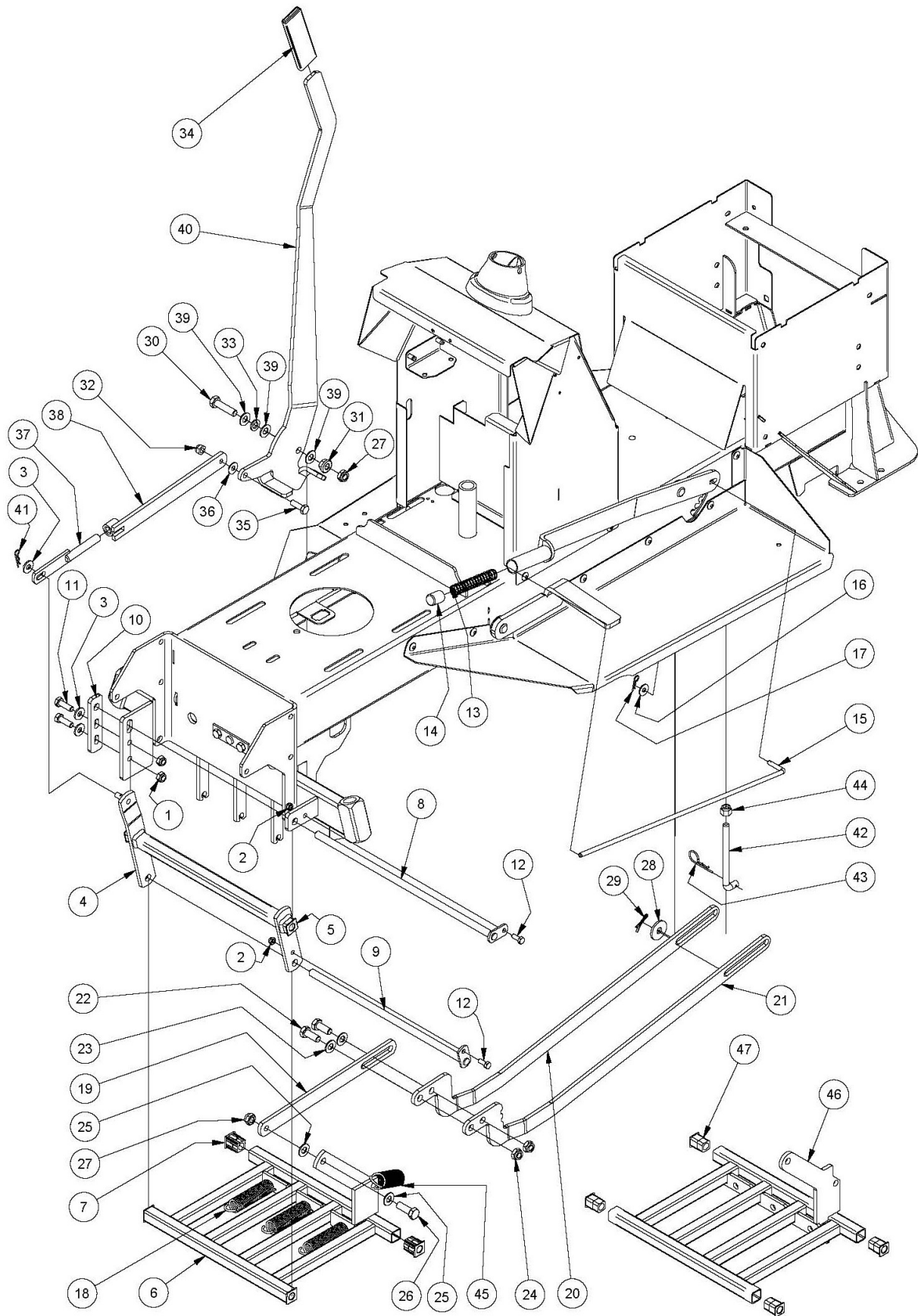

Cutter Control Components

ITEM	PART NUMBER	DESCRIPTION	QTY
1	NM8NT	Nut	4
2	NM6NT	Nut	3
3	W05M202	Washer	3
4	A139104L	Link, Drop, Disengagement, Cutter	1
5	AM369	Bush	2
6	KIT235	Kit, Link, Drag Inc Bushes	1
7	AM369	Bush	4
8	90022	Pin, Pivot	1
9	13016	Pin	2
10	90012	Connecting Link Adjuster Bracket	1
11	SH0825M	Screw	2
12	SH0616M	Screw	3
13	AM012	Height Adjustment Pawl Push Rod Spring	1
14	AM013Q2	Height Adjustment Pawl Push Rod Button	1
15	A108003Z	Rod, Adjust, Height, Cut	1
16	W041216	Washer	1
17	RP04	Pin, 'R'	1
18	AM040	Spring, Extension	3
19	A139008Z	Link, Adjust, Suspend, Front	1
20 & 21	A141010Z	Link, Float, Suspend, Rear Mowing Attachment 32" & 38"	1
22	SH1025M	Screw	2
23	W10MN	Washer	2
24	NM10NT	Nut	2
25	W10MN	Washer	2
26	SH1030M	Screw	1
27	NHCM10	Nut	2
28	W0620HD	Washer	1
29	CP3-220	Pin, Split	1
30	B1040M	Bolt	1
31	NFM10	Nut	1
32	NM8NT	Nut	1
33	WSM10X3.7X2.5	Washer, Lock, Spring	1
34	AM009	Hand Grip	1
35	SH0825M	Screw	1
36	W051218	Washer	1
37	A139020Z	Link, Adjust, Disengagement	1
38	A139018Z	Link, Disengagement	1
39	W10M	Washer	3
40	A135105L	Lever, Disengage, Cutter	1
41	RP01	Pin, 'R'	1
42	AM185BO	Cutter Lifting Link	1
43	RP03	Pin, 'R'	1
44	NF06CN	Nut	1
45	AM145	Spring, Extension, Weight Compensating	1
	A118039	Spring, Extension, Wt Compensating, 38" Mowing Attachment	1
46	KIT235	Kit, Link, Drag, Attachment, Mowing, Inc Bushes	1
47	AM230	Bush - Plastic	4

32" Cutter Attachment & Components

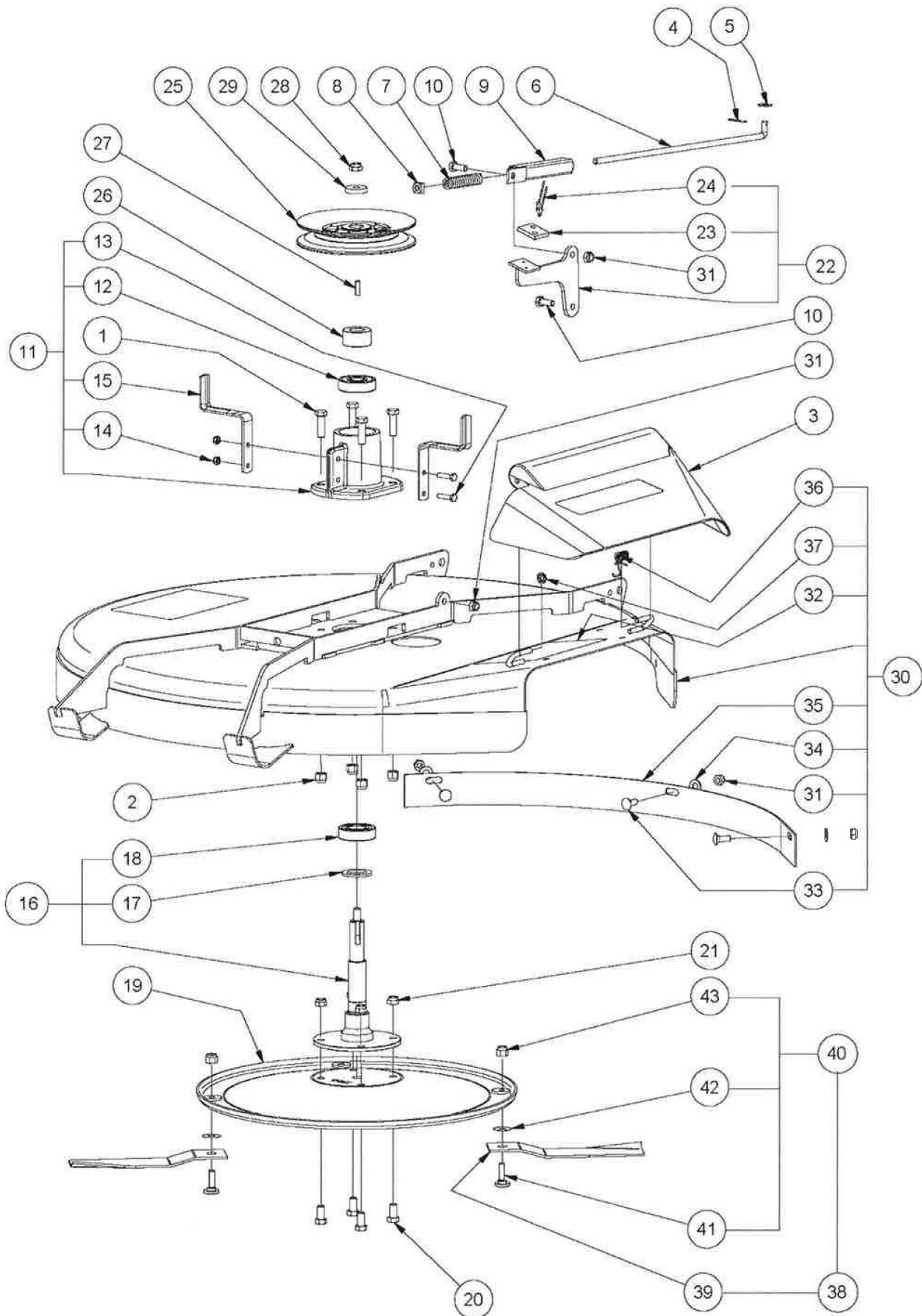

32" Cutter Attachment & Components

ITEM	PART NUMBER	DESCRIPTION	QTY
1	B0620C	Bolt	4
2	NF06CN	Nut	4
3	AM259	Deflector	1
4	RP01	Pin, 'R'	1
5	W051218	Washer	1
6	251301	Rod, Adj, Cutter Brake	1
7	AM035	Spring, Compression, Cutter Brake	1
8	NS05C	Nut, Square	1
9	AM034H0	Cutter Head Brake Adj Brkt	1
10	SH0830M	Screw	2
11	A100009	Sub-Assy, Housing, Bearing, Cutter	1
12	BB205215NS	Bearing, Ball	1
13	B0635M	Bolt	2
14	NM6N	Nut	2
15	A100013Z	Guide, Belt, Cutter	2
	A100027Z	Brace	2
16	A10000712B	Sub-Assy, Spindle	1
17	A100021Z	Washer	1
18	BB255215NN	Bearing, Ball	1
19	AM07604A	Disc, Cutter	1
20	SH0612C	Screw	4
21	N06CN	Nut	4
22	A100010	Lever, Brake, Cutter	1
23	AM033195	Pad, Brake, Cutter	1
24	PR0205	Rivet	2
25	A100017	Pulley, Cutter	1
26	A100023Z	Spacer, Sleeve	1
27	A100025	Key	1
28	SH1030M	Screw	1
29	13247	Washer	1
	WSM10X3.7X2.5	Washer	1
30	KIT199	Kit, Housing, Cutter	1
31	NM8NT	Nut	4
32	DEC116	Decal, Danger, Mowing Attachment	2
33	BCHSNM8X20	Bolt, Cup, Sq Neck	3
34	W061216	Washer	3
35	A100030L	Deflector, Front, Cutter	1
36	A100003	Spring, Torsion, Deflector	1
37	AM274	Fastener, Push-on	1
38	SKIT54N	32 " Stepped Blade/Bolt/Nut Set	1
	SKIT55N	32" Hi-Lift Blade/Bolt/Nut Set (Optional)	
39	SMB198S	Blade, Heavy Duty, Stepped	1
	SMB198A	Blade, Heavy Duty, Hi-Lift (Optional)	
40,41,42	SKIT01D1	Blade Bolt & Nut Set	1
43	NF06CN	Nut	1
	V13	Belt	1

32" Cutter Attachment & Components

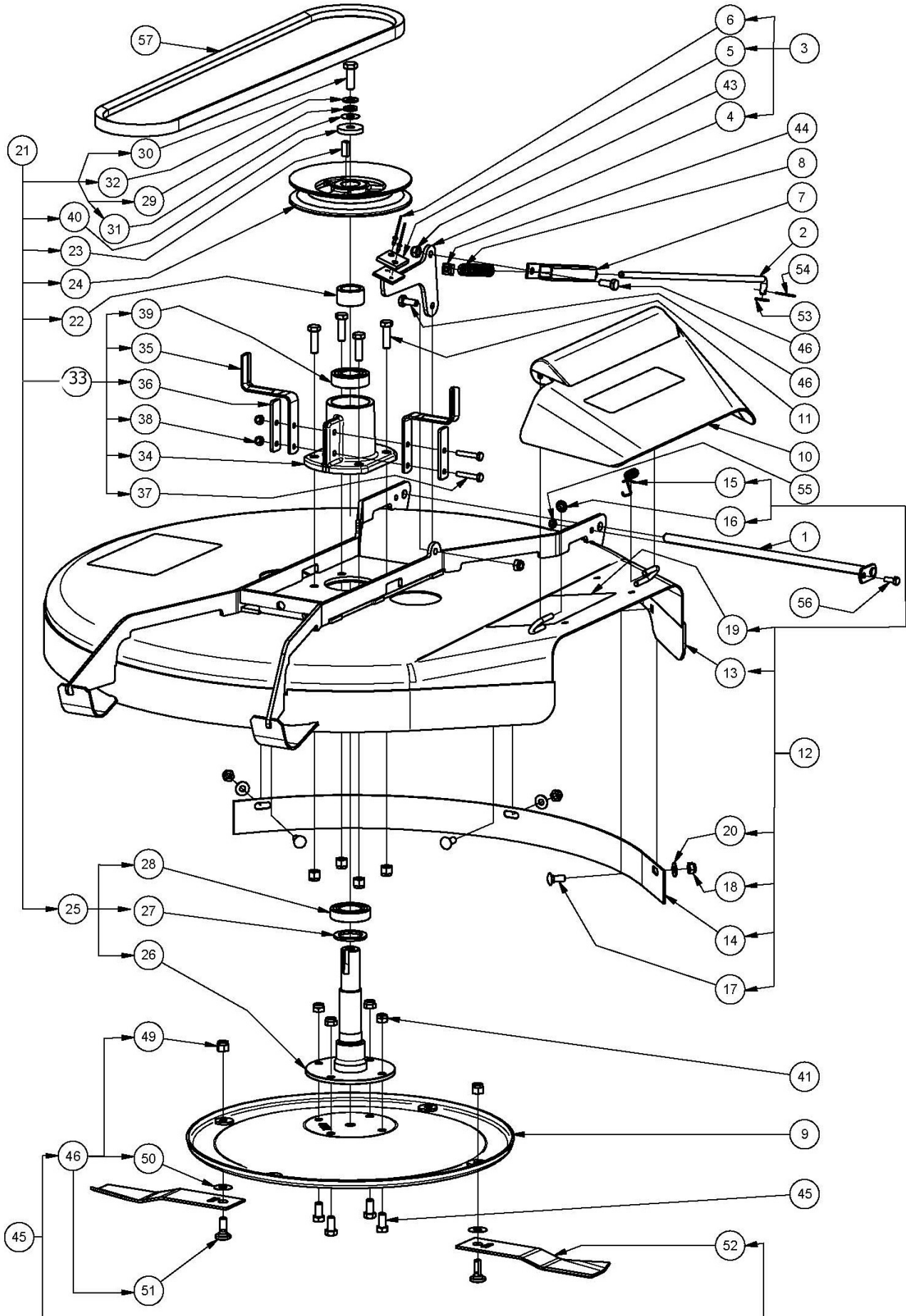

32" Cutter Attachment & Components

ITEM	PART NUMBER	DESCRIPTION	QTY
1	13016	Pin	1
2	251301	Rod, Adj, Cutter Brake 387mm 32"Cut	1
3	A100010	Lever, Brake, Cutter, Lawnboss	1
4		Arm, Lever, Brake, Cutter, Lawnboss	1
5	AM033I95	Pad, Brake, Cutter	1
6	PR0205	Rivet	2
7	AM034H0	Cutter Head Brake Adj Brkt	1
8	AM035	Spring, Compression, Cutter Brake	1
9	AM07604A	Disc, Cutter	1
10	AM259	Deflector, Cox Logo	1
11	B0620C	Bolt	4
12	KIT199	Kit, Housing, Cutter, 805(32")	1
13		Deck, Cutter, 805(32"),Lawnboss	1
14	A100030L	Guard, Cutter, 805(32")	1
15	A100003	Spring, Torsion, Deflector	1
16	AM274	Fastener, Pushon, Round, 1/4"	1
17	BCHSNM8X20	Bolt, Cup, Sq Neck	3
18	NM8NT	Nut	2
19	DEC116	Decal, Danger, Mowing Attachment	2
20	W051218	Washer	2
21	KIT253	Kit, Head, 25, Cutter, 805(32"),Lawnboss	1
22	A100050Z	Spacer, Sleeve	1
23	A100052	Key	1
24	A100056	Pulley,Cutter, Ci	1
25	A100062	Kit, Sub-Assy, Spindle, Flanged, 25, Lawnboss	1
26		Spindle, Flanged, Cutter	1
27	A100060Z	Washer	1
28	BB305513NS	Bearing, Ball	1
29	WSM10X3.66X2.69	Washer, Lock, Spring	1
30	SH1030M10.9	Screw	1
31	WW0616	Washer, Wave	1
32	W10MN	Washer	1
33	A100064	Sub-Assy, Housing, Bearing, Cutter	1
34		Housing, Bearing	1
35	A100013Z	Guide,Belt,Cutter	2
36	A100027Z	Brace,Guide,Belt	2
37	B0635M	Bolt	2
38	NM6N	Nut	2
39	BB255215NN	Bearing,Ball	1
40	W103506	Washer	1
41	N06CN	Nut	4
42	NF06CN	Nut	4
43	NM8NT	Nut	3
44	NS05C	Nut, Sqr	1
45	SH0612C	Screw	4
46	SH0820M	Screw	2
47	SKIT54N	Pair, Blade+Bolt+Washer+Nut	1
48	SKIT01D1	Blade Bolt & Nut Set	1
49		Nut	2
50		Washer, Wave	2
51		Blade Bolt Grade 8	2
52		Blade, Mower, Swingback, Standard, 198	2
53	W051218	Washer	2
54	RP01	Pin, 'R'	1
55	NM6NT	Nut	1
56	SH0616M	Screw	1
57	V13	Belt,V	1

960mm 38" Cutter Attachment Components

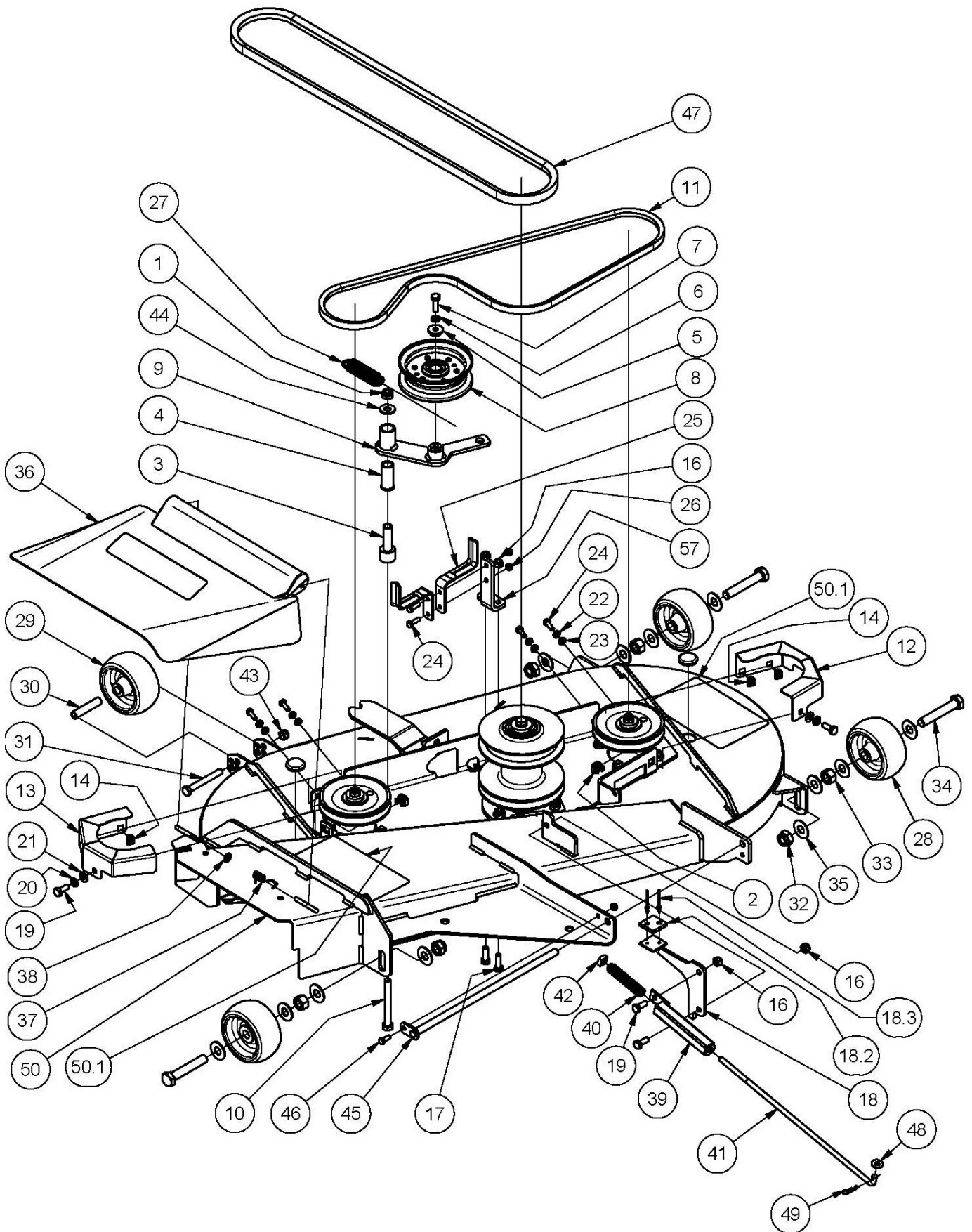

960mm 38" Cutter Attachment Components

ITEM	PART NUMBER	DESCRIPTION	QTY
1	NM10NT	Nut	12
2	NCM8X4.75	Nut, Cage	2
3	A152043Z	Axle, Tensioner	1
4	AM017C1	Steering Shaft Bush With Collar	1
5	14025	Boss, Idler	1
6	WS050216	Washer, Lock, Spring	1
7	SH0825M	Screw	1
8	PIFBB03	Idler, Flat	1
9	A152017Z	Arm, Tensioner, Belt	1
10	B1090M	Bolt	1
11	V59	Belt, V	1
12	A152153L	Guard, Pulley, Left	1
13	A152155L	Guard, Pulley, Right	1
14	NCM6X1.6X9.5	Nut, Cage	4
16	NM8NT	Nut	4
17	SH0825M	Screw	2
18	A152172	Arm, Brake, Cutter, 38", Lawnboss	1
18.2	AM033I95	Pad, Brake, Cutter	1
18.3	PR0205	Rivet	2
19	SH0820M	Screw	4
20	WS050216	Washer	2
21	W08MN	Washer	2
22	WS040816	Washer, Lock, Spring	4
23	W06MN	Washer	4
24	SH0620M	Screw	6
25	AM073	Belt Guides	2
26	NM6NT	Nut	3
27	AM264	Spring	1
28	A152062	Wheel	3
29	AM25703H	Wheel	1
30	AM258	Flotation Wheel Bush	1
31	B0648C	Bolt	1
32	N14MN	Nut	3
33	NHM14	Nut	3
34	B1480M	Bolt	3
35	W092016	Washer	12
36	AM259	Deflector	1
37	A100003	Spring, Torsion, Deflector	1
38	AM274	Fastener, Pushon	1
39	AM034H0	Cutter Head Brake Adj Brkt	1
40	AM035	Spring, Compression, Cutter Brake	1
41	13317	Rod, Adjust, Brake, Cutter	1
42	NS05C	Nut, Sqr	1
43	N06CN	Nut	1
44	W10M	Washer	1
45	13016	Pin	1
46	SH0616M	Screw	1
47	V61	Belt, V	1
48	W051218	Washer	1
49	RP01	Pin, 'R'	1
50	KIT242	Deck, Mower, Side, 960(38"), Fab, Bk, +Decals	1
50.1	DEC116	Decal, Danger, Mowing Attachment	2

960mm 38" Cutter Attachment Spindle Components

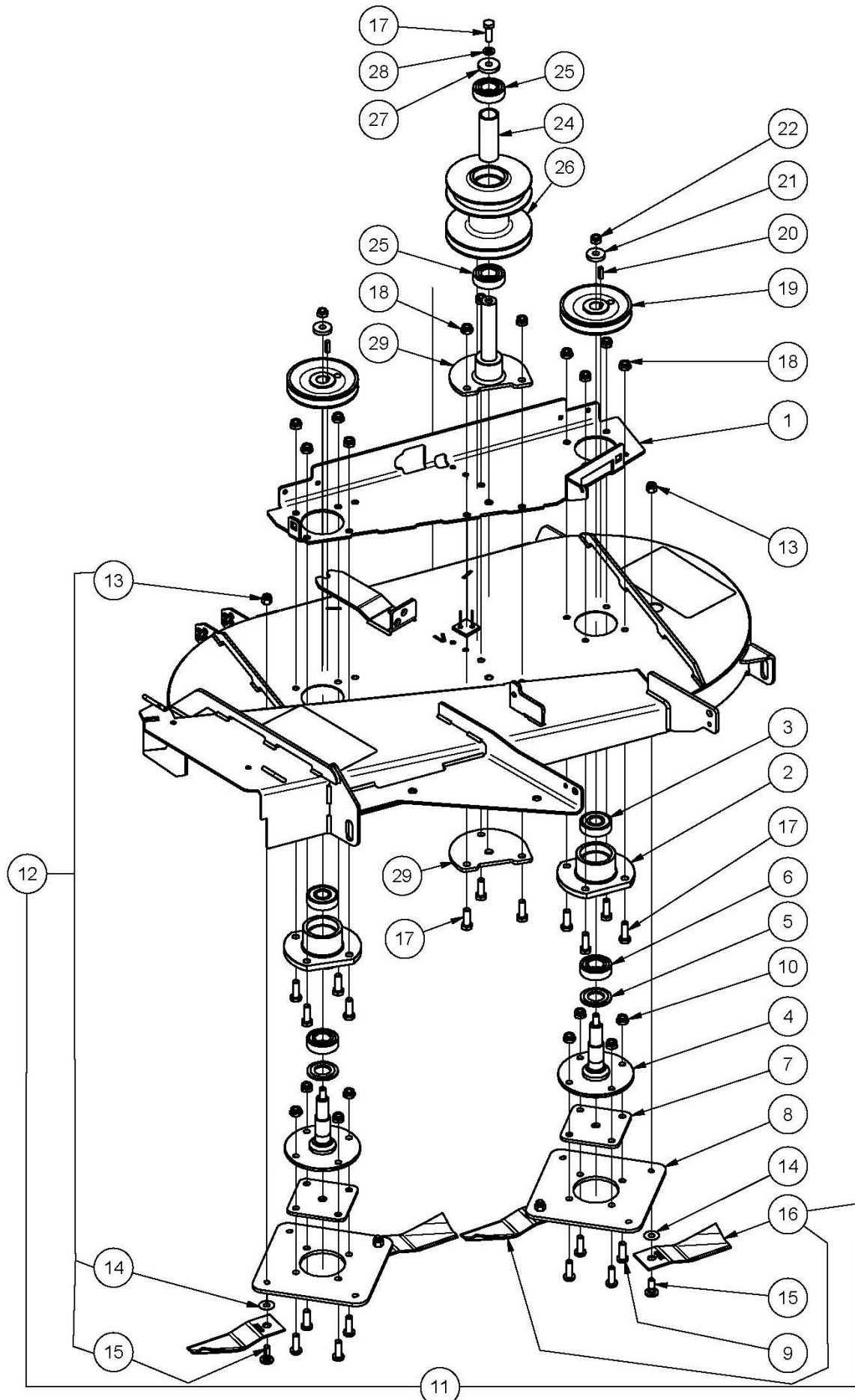

960mm 38" Cutter Attachment Spindle Components

ITEM	PART NUMBER	DESCRIPTION	QTY
1	A152103L	Frame, Reinforce	1
2	A152005B	Housing, Bearing, Flange, Short	2
3	BB205215NS	Bearing, Ball	2
4	A15202012K	Kit, Spindle, Flanged, Cutter	2
5	A118012Z	Shield, Bearing	2
6	BB255215NN	Bearing, Ball	2
7	A152011B	Spacer, Disc, Cutter	2
8	A152013B	Disc, Cutter	2
9	BHSSM10X30	Screw, Button	8
10	NM10NT	Nut	8
11	SKIT41N	Pair, Blade+Bolt+Washer+Nut, Airflow	2
12	SKIT01D1	Blade Bolt & Nut Set	2
13		Nut	1
14		Washer, Wave	1
15		Blade Bolt Grade 8	1
16	SMB137A	Pair, Blade, Mower, Swingback, Airflow	1
17	SH1030M	Screw	12
18	NM10NT	Nut	11
19	A118003	Pulley, Cutter, CI	2
20	A100025	Key	2
21	WSM10X3.7X2.5	Washer, Lock Spring	2
22	SH1030M10.9	Bolt	2
23	9801611M	Flange	1
24	A152183	Sleeve, Spacer, Bearing	1
25	BB255215NN	Bearing, Ball	2
26	A152181	Pulley, Transfer	1
27	W103506	Washer	1
28	WS103.52.2	Washer, Lock, Spring	1
29	A152115L	Axle, Flanged	1

DECALS

ITEM	PART NUMBER	DESCRIPTION	QTY
1	13094	Pad, Non-Skid, Running Board	2
2	DEC08505K	Decal, Warning, Fuel	1
3	8906608A	Non-Skid, Pedal, Drive	1
4	95067	Non-Slip, Brake Pedal	1
5	DEC116	Decal, Danger, Mowing Attachment	2
6	DEC269	Decal, Lawn Boss, Proudly Australian	1
7	DEC270	Decal, Lawn Boss Bonnet	2
8	DEC124	Decal, Brake	1
9	DEC125	Cutter Disengage	1
10	DEC127	Mount This Side Only	1
11	DEC135	Decal, Caution, Hot Muffler	1
12	DEC136	Decal, Drive Pedal	1
13	DEC248	Decal, Lawn Boss, Console Top	1
14	DEC275	Decal, Lawn Boss, Dash	1
15	DEC271	Decal, Lawn Boss, 13 Hp	2
	DEC272	Decal, Lawn Boss, 16 Hp	2
	DEC273	Decal, Lawn Boss, 16.5 Hp	2
	DEC274	Decal, Lawn Boss, 18.5 Hp	2
	DEC296	Decal, Lawn Boss, 19.5 Hp	2
16	DEC199	Decal, Guard Infill, Lawn Boss L/H	1
17	DEC200	Decal, Guard Infill, Lawn Boss R/H	1
18	DEC224	Decal, Park Brake, Lawn Boss	1
	DEC299	Decal, Oil Transaxle	1

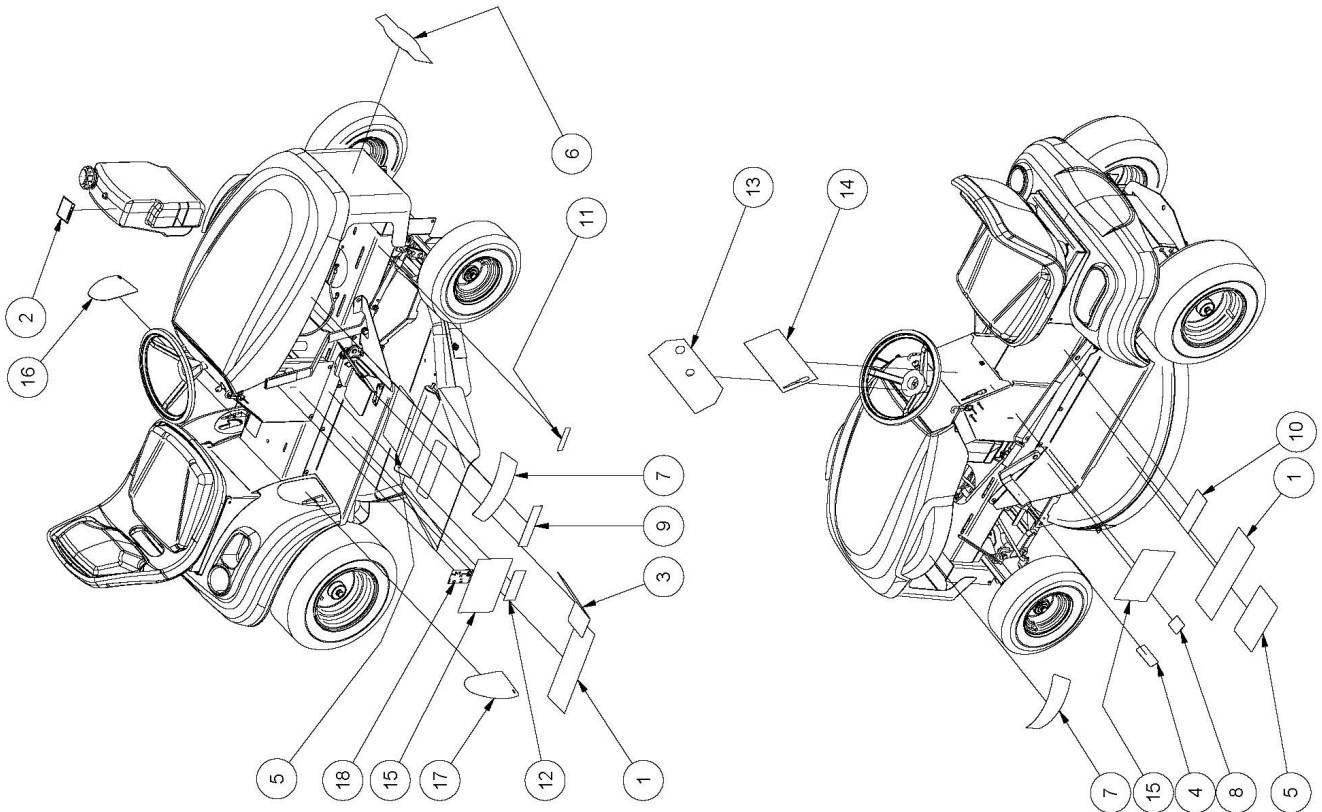



COX INDUSTRIES MOWER WARRANTY POLICY

DEFINITIONS:

"Commercial Use" means all uses other than Domestic use, including any use that is income producing, rental, or is in relation to use in schools, by government departments or charity operators.

"COX INDUSTRIES" means Cox Industries (Australia) Pty Ltd ACN 050 991 038.

"Dealer" means an authorised COX INDUSTRIES dealer a list of which can be found on our website: www.coxmowers.com.au or freecall us on 1800 330 444.

"Domestic Use" means use for a personal, residential or household (property) purpose.

"Mower" means any ride-on mower manufactured by COX INDUSTRIES.

"Parts" means all parts that can be found in a Mower.

"Warranty Period" means:

- 1) for Domestic Use, a period of two (2) years; or
- 2) for Commercial Use, a period of six (6) months, from the original date of purchase.

NEW MOWER:

Our goods come with guarantees that cannot be excluded under the Australian Consumer Law. You are entitled to a replacement or refund for a major failure and compensation for any other reasonably foreseeable loss or damage. You are also entitled to have the goods repaired or replaced if the goods fail to be of acceptable quality and the failure does not amount to a major failure.

Nothing in this Warranty purports to modify or exclude the conditions, warranties and undertakings, and other legal rights, under the Australian Consumer Law. This Warranty gives you additional protection for your Mower, and identifies a preferred approach to resolving warranty claims which will be quickest and simplest for all parties, subject to the exclusions, terms and conditions below.

WARRANTY PERIOD:

COX INDUSTRIES warrants in respect of each new Mower sold that, subject to the exclusions below, for the Warranty Period COX INDUSTRIES or a Dealer will repair or replace free of charge any Parts found to be defective in materials or workmanship under normal use and operating conditions. Other than for major failure, it is at COX INDUSTRIES sole discretion as to whether the Mower or Part is repaired or replaced.

MOWER PARTS INSTALLED DURING NEW MOWER WARRANTY PERIOD:

Warranty coverage for Parts installed during the new Mower Warranty Period shall consist of the remainder of the new mower Warranty Period or ninety (90) days, whichever ever is greater, provided the installation is performed by an authorised Dealer.

TO CLAIM THE WARRANTY:

To make a claim under this Warranty, please bring or send the Mower to an authorised Dealer with a copy of your proof of purchase of the Mower. A claim under this Warranty is not formally made unless and until that proof of purchase is provided. This does not detract from your statutory rights.

WARRANTY REGISTRATION:

The warranty registration card must be completed by the Dealer with the customer at the time of purchase and returned to COX INDUSTRIES within 14 days.

This Warranty is transferable to a subsequent owner of a Mower, in the event of the sale of that product, provided that COX INDUSTRIES is informed in writing within a reasonable time of the sale of the subsequent owner's name and contact details, such notice to be provided to COX INDUSTRIES. The notice should identify the name of the previous owner of the Mower, place and date of purchase, model, make and serial number of the Mower. The effective transfer of this Warranty does not otherwise alter the terms of this Warranty in any way.

WARRANTY EXCLUSIONS:

This Warranty does not cover:

- 1) the costs of rental of another machine or related equipment while repairs are in progress;
- 2) telephone, facsimile or other related communication expenses.
- 3) transportation and insurance charges during transportation of failed Mower or any part thereof;
- 4) the labour, parts, mechanical adjustments or lubricant costs which, in the judgement of COX INDUSTRIES or their Dealer, should have been made as standard maintenance according to the COX INDUSTRIES maintenance schedule;
- 5) the replacement of or service costs relating to replacing and maintaining consumable parts which have ceased working through normal wear and tear such as, but not limited to, normal maintenance parts such as mower discs, blades, bolts and nuts, vee belts, bearings, chains and clutch cones;
- 6) any damage or defect caused by alteration, modification, fitment of a non-genuine part or attachment not approved by COX INDUSTRIES or repair, modification or work carried out on the Mower other than by a Dealer;
- 7) any defect caused by misuse, negligence, accidents or failure to carry out proper maintenance procedures;
- 8) damage caused by continued operation of the machine after it is known to be defective;
- 9) any other expenses incurred by the consumer in making the warranty claim;
- 10) damage caused by incorrect or improper operation (including racing or similar activities), maintenance or not following the instructions or maintenance requirements of the Mower in accordance with the instructions provided with the Mower;
- 11) damage caused by failure to clean or improper cleaning of the product;
- 12) damage caused by adverse external conditions such as thunderstorm activity, acts of God, acts of terrorism, damage caused by vermin, or any other act or circumstance beyond COX INDUSTRIES' control; or
- 13) damage caused by exposure to excessive heat, moisture or dampness, or exposure to abnormally corrosive conditions.

For the avoidance of any doubt, any and all warranties or conditions which are not guaranteed under the Australian Consumer Law or the Australian Competition and Consumer Regulations 2010 and which are not expressly included in this Warranty as additional warranties or conditions are excluded.

To the extent applicable by law, COX INDUSTRIES will not accept liability for costs of labour, postage, cartage or delivery to replace faulty materials or parts, or for any loss, damage or accident directly, indirectly, or consequently suffered by the purchaser, operator or any other person or property as a result of such faults whether due to defective materials or workmanship or otherwise.

Due to COX INDUSTRIES on-going commitment to product improvement, we reserve the right to change at any time, product specifications, configurations and company policies.



Cox Industries (Australia) Pty Ltd

**70 Landseer Street
Acacia Ridge Qld 4110
Australia**

PH 07 3323 2222 FAX 07 3344 6233

Web Site Address: www.coxmowers.com.au

Email: sales@cox-mowers.com.au