



Model A12611E

**16.5HP B&S 32" Cut
21HP B&S 32" Cut & 40" Cut Side Discharge**

Stockman PRO Ride-On Mower

OWNER/OPERATORS MANUAL

READ THIS MANUAL BEFORE OPERATING MACHINE

**DEATH, PERSONAL INJURY AND/OR PROPERTY DAMAGE MAY OCCUR UNLESS
INSTRUCTIONS IN THIS MANUAL ARE FOLLOWED**

NOTE: Bring this Manual when Service & or Warranty work is required.



OWNERS INFORMATION

PRODUCT CODE: _____ **SERIAL NO:** _____

Located on label inside transmission housing

ENGINE (Located on Engine)

B&S MODEL NO: _____ **TYPE** _____ **CODE** _____

DATE OF PURCHASE: _____

ISSUED TO:

OWNERS NAME: _____

ADDRESS: _____

TOWN/CITY: _____ **STATE:** _____

ISSUED BY:

**AUTHORISED COX DEALER/
DISTRIBUTOR:** _____

ADDRESS: _____

TOWN/CITY: _____ **STATE:** _____

PRE DELIVERY CHECK LIST

Check parts Assemble Service Instruction

ALWAYS KEEP THIS MANUAL IN A SAFE PLACE.

SAFETY INSTRUCTIONS

- Read, understand, & follow all instructions in the Owner/Operators manual.
- Know the controls and how to stop the engine quickly in an emergency.
- Allow only responsible adults, who are familiar with the instructions in this manual, to operate the machine.
- Clear the area to be mowed of loose objects such as sticks, stones, bones, wire, toys, debris, etc., which could be picked up and thrown by the blades.
- DO NOT mow whilst people, especially children, or pets are in the mowing area.
- DO NOT mow either direction on slopes beyond 15 degrees, (1 in 3.75).
- Exercise extreme caution on slopes.
- Reduce speed on slopes and in sharp turns to prevent overturning or loss of control.
- Start or stop slowly when on slopes.
- Mow up and down slopes, not across the slope.
- Stay alert for holes or bumps in the terrain and other hidden hazards.
- Use care when pulling loads-
 - a] Use only approved hitch point;
 - b] limit loads to those you can safely control;
 - c] Do not turn sharply;
 - d] use care when backing up.
- Watch out for traffic when crossing or operating the mower near roadways.
- Stop the blades rotating before crossing surfaces other than grass.
- When using attachments, never direct discharge of material toward bystanders nor allow anyone near the machine while it is in operation.
- Before leaving the operators position-
 - a] Disengage all clutches and secure cutting units;
 - b] Return drive pedal to neutral position and set the parking brake;
 - c] Stop the engine and remove the key.
- Disengage drive to attachments and stop engine-
 - a] Before refueling.
 - b] Before removing grass-catcher;
 - c] Before clearing blockages from chute;
 - d] Before checking, cleaning or working on the mower;
 - e] After striking a foreign object (check the mower for damage and make repairs before restarting and operating the equipment);
 - f] If machine starts to vibrate abnormally (check immediately).
- Disengage drive to attachments when transporting or not in use.
- A mower operator should be in good physical and mental health and not under the influence of alcohol or any drug which might impair vision, co-ordination or judgment.
- Never mow while barefoot or wearing open sandals or thongs. Wear long trousers and heavy shoes.
- It is advisable to wear suitable eye protection when operating a mower.
- Mow only in daylight or good artificial light.
- Before using, always visually inspect to see that blades, bolts and cutter assembly are not worn or damaged. Replace worn or damaged blades and bolts in sets to preserve balance.
- Check all nuts, bolts, and screws often; always be sure the mower is in safe operating condition.
- Keep safety devices (guards and switches) in place and in working order.
- Never use the mower unless the grass catcher, or guards provided by the manufacturer, are in position.
- Ensure any replacement parts used comply with the original manufacture's recommendations and specifications.
- Replace worn or faulty silencers.
- Keep machine free of grass, leaves or other debris, excessive oil, grease, or spilt fuel. These can be a fire hazard.
- Refuel outdoors only. Do not smoke while fueling engine. Never remove the cap of the fuel tank or add petrol while the engine is running or the engine is hot. Remove fuel cap slowly to relieve any tank pressure. If fuel is spilled, do not attempt to start the engine but move machine away from the area of the spill and avoid creating any source of ignition until fuel vapors have dissipated.
- Check for fuel leaks while refueling, before and while using the mower. If a fuel leak is found, do not start or run the engine until the fuel leak is fixed and spilled fuel is wiped away.
- Do not operate engine in a confined space where exhaust fumes (carbon monoxide) can collect.
- Always mount the mower from the left or the opposite side to the discharge chute.
- Start the engine carefully with the cutting means disengaged.
- Do not over-speed the engine or alter governor settings. Excessive speed is dangerous and shortens mower life.
- Stop the engine whenever you leave the mower, even for a moment.
- Store the mower in a well-ventilated room away from naked flames such as may be found in hot water heaters.
- Do not lend or sell the mower, without the owners/operators Manual.

PRE-DELIVERY INSTRUCTIONS

UNPACKING INSTRUCTIONS

Inspect the shipping crate and contents for damage. Position the shipping crate on a firm flat level surface with at least 2.1 meters distance from any obstruction to the end of the crate adjacent to the front of the tractor. Cut and remove the straps restraining the tractor to the ends of the shipping crate.

! Caution you can be seriously injured by the metal strapping which has sharp edges and can spring out when cut. Wear gloves when handling metal strapping.

Remove the end of the shipping crate adjacent to front of the tractor.

! Caution you can be seriously injured by sharp nails protruding from the shipping crate.

Remove the plastic sheet covering the tractor. Unlock the park brake by pushing down on brake pedal on the left side of the tractor. Pull the tractor from the shipping crate. Depress the brake pedal while lifting up on the park brake knob. Once the park brake knob is raised release the brake pedal and then the park brake knob. The Park brake should now be locked on.

Remove the steering wheel, seat, & accessories from the tractor.

Dispose of all packaging material responsibly. Do not leave the plastic sheet unrestrained, it can blow away to become a safety hazard.

PRE-DELIVERY INSTRUCTIONS

The purpose of this section of the manual is to ensure the dealer makes the necessary installations, adjustments and checks, before the machine is operational. This begins upon receiving the crated mower and is finalised once the mower has been sold. This is the minimum amount of work required; however it should not be limited to the areas detailed in this procedure.

RESPONSIBILITY

It is the responsibility of the dealer to ensure that before a machine is delivered to a customer, it is in satisfactory operational condition.

PROCEDURE

1. UNPACK PARTS

Check parts supplied within plastic bag in seat protection bag against the following list:

- 1 Owner/Operators Manual
- 1 Engine Owners Manual
- 1 Steering wheel Assembly (SW14H)
- 1 Tube spanner AM006C1)
- 1 Tommy bar (AM007)
- 1 Spark plug tube spanner (AM295)
- 1 Spark plug tube spanner tommy bar (AM296)
- 1 Ignition key set (90134)
- 2 Clutch clearance gauges (13126)
- 1 Spring pull hook (13127)
- 1 Pin (DP10)
- 4 5/16" unc Nyloc Nuts (N05CN)
- 2 5/16" Washers (W05M202)
- 2 Conical Springs (13060)
- 2 Black Caps (14128)

2. ASSEMBLE

TOOLS & EQUIPMENT REQUIRED:

Socket set containing 1/2" a/f socket & extension 75mm (3") or longer. Spanner, 1/2" a/f. Hammer & 6mm or 1/4" pin punch. If Battery charger 12V, 4 or 8amp is required socket set containing 10 mm a/f socket & Spanner 10 mm a/f is also required.

STEERING WHEEL

To attach the steering wheel, align the hole in the steering wheel boss to the hole in the steering shaft and use a hammer and suitable punch to drive the DP10 roll pin in, through the hole in the steering shaft cover into the steering wheel and shaft. Ensure that the pin is situated centrally in the steering wheel boss and that the steering is free to turn.

SEAT

Remove the thread protectors attached to the studs of the seat runners, connect wiring to the seat switch, locate studs of the seat assembly runners through the seat mount, attach nuts to the front studs, attach conical springs, washers, & nuts to the rear studs, attach caps to the base of the springs, as per pictorial procedure provided.

MOWING ATTACHMENT DEFLECTOR

Using a suitable spring hook, reposition deflector spring from the under side of the deflector to above the deflector for the correct safe operation.

HOURLY METER

Connect the black negative wire to the terminal supplied at the back of the hourmeter.

NOTE -The Hourmeter will continue to operate if the ignition switch is on.

3. SERVICE

BATTERY

(If unused for 3 months or more)

- Remove R.H Side cover and rear console cover, then remove battery retaining bracket.
- Remove the black battery lead first then the red battery lead from battery
- Remove battery from mower and place on level surface.
- Using a 12V, 4 or 8amp battery charger, charge the battery for a period of 30 minutes.
After charging proceed as follows:
Allow battery to stand for 30 minutes.
- Place charged battery back in the battery location tray with terminals towards the right hand side of the mower. Install the red battery lead on to the positive terminal first, and then the black battery lead on to the negative terminal.
- Refit the battery retaining bracket and re-fit covers.

TYRES

Before operation ensure that tyre pressures are equal. The recommended pressure is: Front 100kPa (15 P.S.I.). Rear 100kPa (15 P.S.I.)

ENGINE OIL

Before operation ensure that engine oil level is to the full mark on the dipstick. (Refer to Engine Owners Manual for correct oil classification to use).

FUEL TAP

Ensure the fuel tap (lower left front corner of fuel tank) is turned to the on position before attempting to start engine. (Use unleaded fuel only).

CLUTCH PLATE

Start engine and run for approximately 1 minute at about half throttle, switch engine off to allow clutch arm to centre itself then

loosen the four square head set screws on the clutch plates using tube spanner (AM006C1) and tommy bar (AM007). Insert the clearance gauges supplied, one between the forward clutch plate and cone and the other between the reverse clutch plate and cone and hook them onto the intershaft.

Slide both clutch plates against the clearance gauges and clutch cone tighten the set screws firmly onto the flat on the intershaft. Remove gauges.

4. OPERATIONAL CHECK

SAFETY SWITCHES:

Start Foot switch

Sit on seat with mowing attachment disengaged (Off), attempt to start engine without using the Start foot switch. Engine should not start.

Disengagement switch

Sit on seat with foot on foot switch and cutter engaged (On), attempt to start engine. **Engine should not start.**

Seat switch

(Operator presence)

Sit on seat and start engine, engage cutter, lift weight from seat. **Engine should stop.**

Pictorial Assembly Procedures - Seat



Remove thread protectors



Connect wiring to the seat switch



Locate studs of the seat assembly runners through the seat mount



Attach nuts to the front studs



Attach conical springs, washers & nuts to the rear studs



Attach caps to the base of the springs

Figure 1

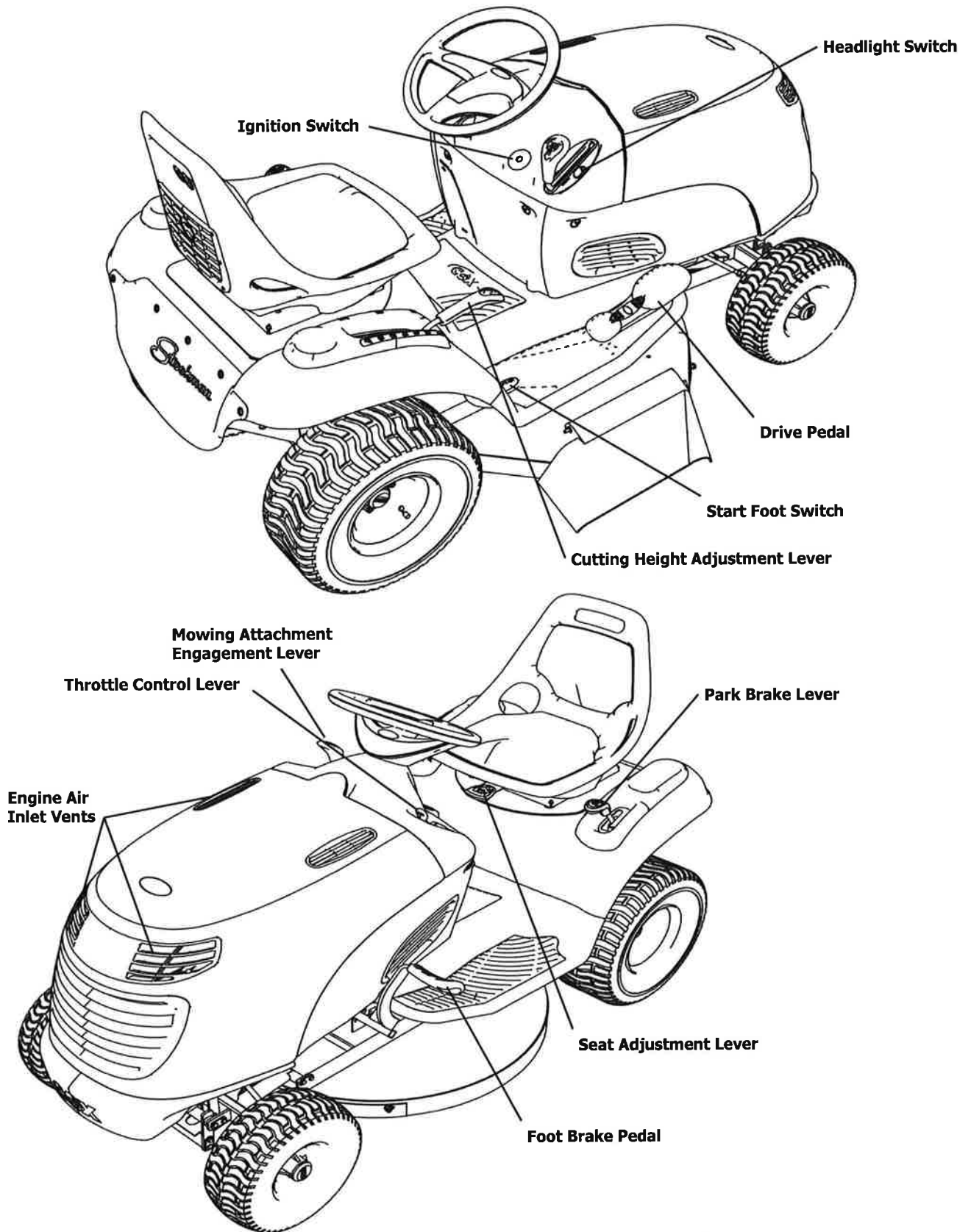

OPERATING INSTRUCTIONS

The controls and their functions are as follows;

Ignition switch-

Used to start and stop engine. Insert key, turn key all the way right to start (3rd) position to start engine. When key is released from start (3rd) position it will return to on | (2nd) position. Turn key all the way left to off O (1st) position to stop engine. Remove key from off O (1st) position to lock ignition switch.

Throttle control lever-

Used to regulate engine speed and cutter speed. Pull lever fully back for slow engine speed. Push lever forward to the orange line for fast engine speed.

Choke control-

Used to start a cold engine. Push throttle control lever up into the choke position to start cold engine. Pull throttle control lever down into the orange range after engine has started.

Headlight switch-

Used to turn headlight on or off. With ignition switch in on | (2nd) position, toggle switch lever back to on | position to turn headlights on. toggle switch lever forward to off O position to turn headlights off.

Mowing attachment clutch/brake control-

Used to start and stop mowing attachment. With engine running at fast speed, ease handle fully backward to on | position to start mowing attachment. Push handle fully forward to off O position to stop mowing attachment.

Cutting height adjustment lever-

Used to change the mowing attachment cutting height. To raise cutting height, pull lever

towards you and up, stop at desired cutting height and push lever into adjacent notch. To lower cutting height, pull towards you and lower the lever to desired height and push lever into adjacent notch.

Drive pedal-

Used to control an infinitely variable ground speed between zero and maximum in forward or reverse. Also to select neutral. With engine running push down on front of pedal to travel forward. With engine running push down on back of pedal to travel in reverse. When pressure is released from front or back of pedal it will return to neutral position. It is not necessary to return to neutral before changing from forward to reverse or reverse to forward.

Foot brake pedal-

Used to stop machine travel before setting park brake. Push pedal down to apply brake. Remove foot from pedal to release brake.

Park brake lever-

Used to keep machine stationary. With drive pedal in neutral position and machine stationary push lever down and away from you to the 'ON' position to apply brake. To release brake simply bump lever down and towards you, the spring tension will return the lever to the 'OFF' position.

NOTE-- Applying park brake while machine is moving and/or attempting to drive off with the park brake not fully in the off position will damage the teeth of the large sprocket.

Start Foot switch -

Used to ensure drive is in neutral when starting engine electrically. Place right foot on

and depress foot switch to start engine with ignition key.

Fuel tap knob-

Used to shut off fuel line when machine is transported or not in operation to prevent fuel leakage. Remove left hand side cover and locate fuel tap at the bottom of the fuel tank. Turn fuel tap knob to right 1/4 turn to off position to shut fuel line. Turn fuel tap knob to left 1/4 turn to on position to open fuel line.

The instruments and THEIR functions are as follows;

Hourmeter-

Used to indicate the number of hours the engine has operated. Note:- If the ignition switch is in the on position with the engine off the hourmeter will continue to operate.

Fuel level windows-

Used to indicate fuel remaining in fuel tank.

Oil level dipstick-

Used to indicate oil level in engine when engine is not running. (Refer to engine owners manual for instructions on checking engine oil level)

STARTING ENGINE

Electric starter:

Cold engine: Check engine oil level, check fuel level, open fuel line. To start engine, place throttle control lever into choke position, ensure mowing attachment clutch/brake control (manual or electrical) is in the off O position, place right foot on and depress start foot switch, insert key in ignition switch, turn key all the way right to start (3rd) position, release key when engine has started. Note: Continuous

(Continued on page 8)

cranking for more than 15 seconds can damage the starter motor. Short starting cycles give best starter motor life. Allow starter motor to cool for 2 minutes before attempting to restart engine. After engine starts, move throttle control out of the choke position and into the orange range, move throttle control lever to obtain desired engine speed.

Hot engine:

To start engine, place throttle control slightly past slow position, ensure mowing attachment clutch/brake control (manual or electrical) is in the off O position, place right foot on and depress foot switch plate, insert key in ignition switch, turn key all the way right to start (3rd) position, release key when engine has started. Move throttle control lever to obtain desired engine speed.

STOPPING ENGINE

When stopping engine, ensure mowing attachment clutch/brake control (manual or electrical) is in the off position, return throttle to slow position, turn ignition switch to the off O (1st) position.

DRIVING - TO TRAVEL MACHINE FORWARD OR REVERSE:

With engine running set throttle control lever to obtain desired engine speed. Apply downward pressure on front of drive pedal with toes to travel forward, or apply downward pressure on back of drive pedal with heel to travel in reverse. It is not necessary to apply foot brake before changing from forward to reverse or reverse to forward. The amount of pressure can be used to control the ground speed, light pressure will give a slow ground speed, heavy pressure will give a fast ground speed. Heavy pressure may also be required when travelling up slopes or when

heavy loads are being towed or carried. Excessive pressure should not need to be applied to the drive pedal to obtain a fast ground speed. When operating the mower on slopes greater than 10 degrees but less than 15 degrees for a prolonged period, you may experience minor clutch fade, should this occur, vary your mowing style eg: mow around some flat areas, then the slope followed by the flat area again. This will allow the drive to cool before travelling up the slope again.

NOTE:

When mowing slopes keep clutch pedal in forward or reverse, depending on the direction of the machine. The low gearing will prevent it from picking up excessive speed. If very steep, it may be necessary to throttle back slightly and or apply a light pedal pressure to the opposite clutch plate. i.e. move clutch pedal into reverse when going forward down a slope or into forward when reversing down a slope. Ensure that when pressure is applied to the drive pedal the back wheel/s start rotating or damage will occur to drive system.

NOTE— Do Not mow either direction on slopes beyond 15 degrees (1 in 3.75).

TO STOP MACHINE TRAVEL

ENGINE RUNNING:

The drive pedal may be used to stop the machine. If traveling forward push the pedal into reverse until machine stops, then bring the pedal back to

neutral position or vice versa if traveling in reverse. Should failure of the drive system occur during operation use the foot brake pedal to stop machine travel.

ENGINE STOPPED:

Use foot brake pedal only.

NOTE:

Damage to clutch cone will occur if clutch pedal is used to stop machine travel with the engine not running.

MANOEUVRING:

Due to the heel and toe type action of the drive pedal, it is possible to take the machine straight from forward to reverse and vice versa without applying the foot brake. This instant forward and reverse operation in conjunction with it tight turning radius makes the machine very maneuverable and the sharpest turns can be negotiated easily and quickly.

Note:

Take care when reversing, always look in the direction of intended travel before changing direction.

DIFFERENTIAL OPTION:

The differential is used to permit the back wheels to rotate at different speeds when maneuvering tight turns avoiding wheel slip which may damage the lawn.

TRANSPORTING

If your machine is transported regularly from site to site, especially by trailer, it is recommended to either adjust clutch plates wide apart (re-tighten bolts) or place cardboard between clutch cone and clutch plates to avoid damaging the clutch cone.

MAINTENANCE SCHEDULE

BEFORE EACH USE

Check engine oil level, adjust if required
Check engine air cleaner foam pre-cleaner, service if req
Check engine rotating screen/finger guard, clean if req
Check engine air inlet console screen, clean if required
Check operation of safety switches, service if required
Check foot brake operation, adjust if required

Lubricate as per required
Check tyre pressures, adjust if required
Grease stub axles
Check mowing attachment cutter blades, bolts, nuts, disc/s, housing, and guards for wear or damage, replace if required
Check for loose fasteners, tighten if required

BEFORE STORAGE

Change engine oil - Clean machine - Lubricate as per required

EVERY 5 HOURS

Check engine oil level, adjust if required
Check engine air cleaner foam pre-cleaner, service if req
Check engine rotating screen/finger guard, clean if required
Check engine air inlet console screen, clean if required*

Lubricate chains (motorcycle chain lube preferred)

*Service more often under dusty conditions, or where air born debris is present

1 MONTH OR 5 HOURS WHICH EVER OCCURS FIRST

Change engine oil
Check engine air cleaner foam pre-cleaner, service if required
Check engine rotating screen/finger guard, clean if required
Check engine air inlet console screen, clean if required
Check foot brake operation, adjust if required
Check operation of safety switches, service if required
Check tyre pressures, adjust if required

Grease stub axles
Check for loose fasteners, tighten if required
Check clutch arm action, adjust if required
Check mowing attachment cutter blades, bolts, nuts, disc/s, housing, and guards for damage, replace if required

DATE / / HOURS.....DEALER.....

3 MONTH OR 25 HOURS WHICH EVER OCCURS FIRST

Change engine oil if operating under heavy load or high ambient temperature
Check engine air cleaner foam pre-cleaner, service if required *
Check engine rotating screen/finger guard, clean if required *
Check engine air inlet console screen, clean if required *
Check foot brake operation, adjust if required
Check operation of safety switches and replace if required

Check tyre pressures, adjust if required
Grease stub axles *
Check for loose fasteners, tighten if required
Check battery condition, service if required
Check mowing attachment cutter blades, bolts, nuts, disc/s, housing, and guards for wear or damage, replace if required
Lubricate steering & drive chains (motorcycle chain lube preferred)

*Service more often under dusty conditions, or where air borne debris is present

DATE / / HOURS.....DEALER.....

6 MONTH OR 50 HOURS WHICH EVER OCCURS FIRST

Change engine oil
If fitted clean engine exhaust spark arrester
Check engine air cleaner foam pre-cleaner, service if required *
Check engine rotating screen/finger guard, clean if required *
Check engine air inlet console screen clean if required *
Check foot brake operation and lining for wear, adjust or replace if req. Check operation of safety switches, service if required
Check tyre pressures, adjust if required
Grease stub axles *
Check steering chain and sprockets or wear, adjust if required
Check mowing attachment cutter blades, bolts, nuts, disc/s, housing, and guards for wear or damage, replace if required
Check clutch arm action, adjust if required
Check belts for wear or damage, replace if required

Check drive chain and sprockets for wear, replace if required
If fitted dismantle, clean, re-grease, and reassemble differential
If fitted check mowing attachment brake pad for wear, replace if required
If fitted check mowing attachment electric clutch brake air gap, adjust if req
Check for loose fasteners, tighten if required
Check drive clutch plates and cone for wear or damage, adjust or service if req
Check battery condition, service if required
Check & tighten if necessary the clamp around the lower boss of the steering box where it mounts onto the lower steering shaft
Lubricate steering & drive chains (motorcycle chain lube preferred)

*Service more often under dusty conditions, or where air borne debris is present

DATE / / HOURS.....DEALER.....

9 MONTHS OR 75 HOURS WHICH EVER OCCURS FIRST

- Change engine oil if operating under heavy load or high ambient temperature
- Check engine air cleaner foam pre-cleaner, service if required *
- Check engine rotating screen/finger guard, clean if required *
- Check engine air inlet console screen, clean if required *
- Check foot brake operation, adjust if required
- Check operation of safety switches and replace if required
- Check tyre pressures, adjust if required
- Grease stub axles *
- Check for loose fasteners, tighten if required
- Check battery condition, service if required
- Check mowing attachment cutter blades, bolts, nuts, disc/s, housing, and guards for wear or damage, replace if required
- Lubricate steering & drive chains (motorcycle chain lube preferred)

*Service more often under dusty conditions, or where air borne debris is present

DATE / / HOURS.....DEALER.....

12 MONTHS OR 100 HOURS WHICH EVER OCCURS FIRST

- If fitted replace engine oil filter.
- Change engine oil.
- Check engine spark plug, clean, adjust, or replace if required.
- If fitted clean engine exhaust spark arrester.
- Check engine air cleaner foam pre-cleaner, service if required *.
- Check engine air cleaner cartridge, service if required*.
- Clean engine cooling system*.
- Check engine air inlet console screen, clean if required *.
- Replace in-line fuel filter.
- Check foot brake operation and lining for ware, adjust or replace if req.
- Grease stub axles *.
- Check tyre pressures, adjust if required.
- Check operation of safety switches, service if required.
- Check steering chain an sprockets or wear, adjust if required.
- Check drive chain and sprockets for wear, replace if required.
- Check belts for wear or damage, replace if required.
- Check clutch arm action, adjust if required.
- Re-tension rear wheel adaptor retaining nut/s.
- If fitted re-tension differential outer gear retaining bolts.
- Check battery condition, service if required.
- If fitted check mowing attachment brake pad for wear, replace if req.
- If fitted check mowing attachment electric clutch brake air gap, adjust if req.
- Check for loose fasteners, tighten if required.
- Check drive clutch plates and cone for wear or damage, adjust or service if required.
- Check clutch arm action, adjust if required.
- Check mowing attachment cutter blades, bolts, nuts, disc/s, housing, and guards for wear or damage, replace if required.
- Check & tighten if necessary the clamp around the lower boss of the steering box where it mounts onto the lower steering shaft
- Lubricate steering & drive chains (motorcycle chain lube preferred)

*Service more often under dusty conditions, or where air borne debris is present

DATE / / HOURS.....DEALER.....

15 MONTHS OR 125 HOURS WHICH EVER OCCURS FIRST

- Change engine oil if operating under heavy load or high ambient temperature.
- Check engine air cleaner foam pre-cleaner, service if required *.
- Check engine rotating screen/finger guard, clean if required *.
- Check engine air inlet console screen, clean if required *.
- Check foot brake operation, adjust if required.
- Check operation of safety switches and replace if required.
- Check tyre pressures, adjust if required.
- Grease stub axles *.
- Check battery condition, service if required.
- Check for loose fasteners, tighten if required.
- Check mowing attachment cutter blades, bolts, nuts, disc/s, housing, and guards for wear or damage, replace if required.
- Lubricate steering & drive chains (motorcycle chain lube preferred)

*Service more often under dusty conditions, or where air borne debris is present

DATE / / HOURS.....DEALER.....

18 MONTHS OR 150 HOURS WHICH EVER OCCURS FIRST

- Change engine oil.
- If fitted clean engine exhaust spark arrester.
- Check engine air cleaner foam pre-cleaner, service if required *.
- Check engine rotating screen/finger guard, clean if required *.
- Check engine air inlet console screen, clean if required *.
- Check foot brake operation and lining wear, adjust or replace if req.
- Check operation of safety switches, service if required.
- Check tyre pressures, adjust if required.
- Grease stub axles *.
- Check steering chain and sprockets or wear, adjust if required.
- Check belts for wear or damage, replace if required.
- Check drive chain and sprockets for wear, replace if required.
- If fitted dismantle, clean, re-grease, and reassemble differential.
- If fitted check mowing attachment brake pad for wear, replace if required.
- If fitted check mowing attachment electric clutch brake air gap, adjust if req.
- Check drive clutch plates and cone for wear or damage, adjust/ service if req.
- Check clutch arm action, adjust if required.
- Check battery condition, service if required.
- Check for loose fasteners, tighten if required.
- Check mowing attachment cutter blades, bolts, nuts, disc/s, housing, and guards for wear or damage, replace if required.
- Check & tighten if necessary the clamp around the lower boss of the steering box where it mounts onto the lower steering shaft
- Lubricate steering & drive chains (motorcycle chain lube preferred)

*Service more often under dusty conditions, or where air borne debris is present

DATE / / HOURS.....DEALER.....

21 MONTHS OR 175 HOURS WHICH EVER OCCURS FIRST

Change engine oil if operating under heavy load or high ambient temperature.
Check engine air cleaner foam pre-cleaner, service if required *.
Check engine rotating screen/finger guard, clean if required *.
Check engine air inlet console screen, clean if required *.
Check foot brake operation, adjust if required.
Check operation of safety switches and replace if required.

Check tyre pressures, adjust if required.
Grease stub axles *.
Check battery condition, service if required.
Check for loose fasteners, tighten if required.
Check mowing attachment cutter blades, bolts, nuts, disc/s, housing, and guards for wear or damage, replace if required.
Lubricate steering & drive chains (motorcycle chain lube preferred)

*Service more often under dusty conditions, or where air borne debris is present

DATE / / HOURS.....DEALER.....

24 MONTHS OR 200 HOURS WHICH EVER OCCURS FIRST

If fitted replace engine oil filter.
Change engine oil.
Check engine spark plug, clean, adjust, or replace if required.
If fitted clean engine exhaust spark arrestor.
Check engine air cleaner foam pre-cleaner , service if required *.
Check engine air cleaner cartridge, service if required.
Clean engine cooling system*.
Check engine air inlet console screen , clean if required *.
Replace in-line fuel filter.
Check foot brake operation and lining for ware, adjust or replace if req.
Check operation of safety switches, service if required.
Check tyre pressures, adjust if required.
Grease stub axles *
Check steering chain and sprockets or wear, adjust if required
Check belts for wear or damage, replace if required.

Check drive chain and sprockets for wear, replace if required.
If fitted re-tension differential outer gear retaining bolts.
Re-tension rear wheel adapter retaining nut/s.
If fitted check mowing attachment brake pad for wear, replace if required.
If fitted check mowing attachment electric clutch brake air gap, adjust if req.
Check clutch arm action, adjust if required
Check battery condition, service if required
Check for loose fasteners, tighten if required
Check mowing attachment cutter blades, bolts, nuts, disc/s, housing , and guards for wear or damage, replace if required.
Check & tighten if necessary the clamp around the lower boss of the steering box where it mounts onto the lower steering shaft
Lubricate steering & drive chains (motorcycle chain lube preferred)

*Service more often under dusty conditions, or where air borne debris is present

DATE / / HOURS.....DEALER.....

27 MONTHS OR 225 HOURS WHICH EVER OCCURS FIRST

Change engine oil if operating under heavy load or high ambient temperature.
Check engine air cleaner foam pre-cleaner, service if required *.
Check engine rotating screen/finger guard, clean if required *.
Check engine air inlet console screen, clean if required *.
Check foot brake operation, adjust if required.
Check operation of safety switches and replace if required.

Check tyre pressures, adjust if required.
Grease stub axles *.
Check battery condition, service if required.
Check for loose fasteners, tighten if required.
Check mowing attachment cutter blades, bolts, nuts, disc/s, housing, and guards for wear or damage, replace if required
Lubricate steering & drive chains (motorcycle chain lube preferred)

*Service more often under dusty conditions, or where air borne debris is present

DATE / / HOURS.....DEALER.....

30 MONTHS OR 250 HOURS WHICH EVER OCCURS FIRST

Change engine oil.
If fitted clean engine exhaust spark arrestor.
Check engine air cleaner foam pre-cleaner , service if required *.
Check engine rotating screen/finger guard , clean if required *.
Check engine air inlet console screen , clean if required *.
Check foot brake operation and lining for ware, adjust or replace if req.
Check operation of safety switches, service if required.
Check tyre pressures, adjust if required.
Grease stub axles *.
Check steering chain an sprockets or wear, adjust if required.
Check mowing attachment cutter blades, bolts, nuts, disc/s, housing, and guards for wear or damage, replace if required.
Check belts for wear or damage, replace if required
Check drive chain and sprockets for wear, replace if required

If fitted dismantle, clean, re-grease, and reassemble differential
If fitted check mowing attachment brake pad for wear, replace if required
If fitted check mowing attachment electric clutch brake air gap, adjust if req,
Check drive clutch plates and cone for wear or damage. adjust or service if required.
Check clutch arm action, adjust if required.
Check battery condition, service if required.
Check for loose fasteners, tighten if require
Check & tighten if necessary the clamp around the lower boss of the steering box where it mounts onto the lower steering shaft
Lubricate steering & drive chains (motorcycle chain lube preferred)

*Service more often under dusty conditions, or where air borne debris is present

DATE / / HOURS.....DEALER.....

33 MONTHS OR 275 HOURS WHICH EVER OCCURS FIRST

- | | |
|---|---|
| Change engine oil if operating under heavy load or high ambient temperature | Check tyre pressures, adjust if required |
| Check engine air cleaner foam pre-cleaner, service if required * | Grease stub axles * |
| Check engine rotating screen/finger guard, clean if required * | Check mowing attachment cutter blades, bolts, nuts, disc/s, housing, and guards for wear or damage, replace if required |
| Check engine air inlet console screen, clean if required * | Check battery condition, service if required |
| Check foot brake operation, adjust if required | Check for loose fasteners, tighten if required |
| Check operation of safety switches and replace if required | Lubricate drive & steering chains (motorcycle chain lube preferred) |

*Service more often under dusty conditions, or where air borne debris is present

DATE / / HOURS.....DEALER.....

36 MONTHS OR 300 HOURS WHICH EVER OCCURS FIRST

- | | |
|---|---|
| If fitted replace engine oil filter | Check belts for wear or damage, replace if required |
| Change engine oil | Check drive chain and sprockets for wear, replace if required |
| Check engine spark plug, clean, adjust, or replace if required | If fitted re-tension differential outer gear retaining bolts |
| If fitted clean engine exhaust spark arrestor | Re-tension rear wheel adapter retaining nut/s |
| Check engine air cleaner foam pre-cleaner, service if required * | If fitted check mowing attachment brake pad for wear, replace if required |
| Check engine air cleaner cartridge, service if required | If fitted check mowing attachment electric clutch brake air gap, adjust if req |
| Clean engine cooling system* | Check drive clutch plates and cone for wear or damage, adjust/service if req |
| Check engine air inlet console screen, clean if required * | Check clutch arm action, adjust if required |
| Replace in-line fuel filter | Check battery condition, service if required |
| Check foot brake operation and lining for wear, adjust or replace if req. | Check for loose fasteners, tighten if required |
| Check operation of safety switches, service if required | Check & tighten if necessary the damp around the lower boss of the steering box where it mounts onto the lower steering shaft |
| Check tyre pressures, adjust if required | Lubricate drive & steering chains (motorcycle chain lube preferred) |
| Grease stub axles * | |
| Check steering chain an sprockets or wear, adjust if required | |
| Check mowing attachment cutter blades, bolts, nuts, disc/s, housing, and guards for wear or damage, replace if required | |

*Service more often under dusty conditions, or where air borne debris is present

DATE / / HOURS.....DEALER.....

MAINTENANCE INSTRUCTIONS

Before servicing, disconnect spark plug wire and ground it, disconnect battery at negative terminal, to prevent accidental starting.

Reference to the left or right side of the machine is determined by sitting in the operating position.

IMPORTANT

If operating in conditions such as those mentioned below, engine oil, air filtering, chassis lubrication, greasing and adjustments should be serviced at more frequent intervals than specified in this booklet.

- Mowing in damp or wet conditions.
- Mowing in rough or dusty conditions.
- Mowing in hilly areas under heavy load.

Ensure machine has park brake engaged when attempting to start engine. Disengage park brake before applying drive pressure to clutch pedal.

Never alter factory setting of maximum engine R.P.M.

STEERING –

Check, lubricate & adjust the steering chain if necessary
Check & replace steering tie rod ball joints if worn.

DIFFERENTIAL -

For models fitted with a differential it is essential that the maintenance schedule supplied be performed by your COX INDUSTRIES Dealer. This will ensure the differential has trouble free operation and long service life.

CHECK ENGINE OIL LEVEL - Refer to engine owners manual for correct method to check engine oil level.

CHANGE ENGINE OIL -

Refer to engine owners manual for correct method to change engine oil.

CHECK ENGINE AIR CLEANER FOAM PRE-CLEANER -

Refer to engine owners manual for correct method to check and service engine air cleaner foam pre-cleaner.

CHECK ENGINE INLET VENTS -

If Vents are more than one quarter blocked by debris clean Vents.
Wipe vents with hand, rag or brush to remove debris from vent openings.

CHECK ENGINE ROTATING SCREEN/FINGER GUARD –

Refer to engine owners manual for correct method to check and clean engine rotating screen /debris guard.

MAINTENANCE INSTRUCTIONS cont.

CHECK FOOT BRAKE

OPERATION -

Measure the distance between the under side of the pedal rubber to footrest by holding pedal down using hand pressure. If less than 50mm (2") adjust brake. Adjust brake by tightening the nyloc nut on brake pull rod (pedal end) to give 90mm (3 1/2") between the brake pedal rubber and footrest (using hand pressure on brake pedal).

CHECK TYRE PRESSURES -

Adjust front and rear tyre pressure to 100kPa (15psi).

CHECK OPERATION OF SAFETY SWITCHES -

Foot Switch - Sit on seat with cutter disengaged, (manual or electric control) attempt to start engine without using the foot switch. Engine should not start.

Disengagement Switch - Sit on seat with foot on foot switch and cutter engaged, (manual or electric control) attempt to start engine. Engine should not start.

Seat Switch - Sit on seat and start engine, engage cutter, (manual or electric control) and lift weight from seat. Engine should stop.

CHECK FOR LOOSE FASTENERS -

TORQUE SETTINGS

1/4" UNC BOLT/NUT	10Nm (84lbf ft)
5/16" UNF BOLT	23Nm (17lbf ft)
5/16" UNC BOLT/NUT	20Nm (180lbf in)
3/8" UNF BOLT	41Nm (30lbf ft)
3/8" UNC BOLT/NUT	36Nm (27lbf ft)
7/16" UNF BOLT	68Nm (50lbf ft)
1/2" UNC BOLT/NUT	90Nm (66lbf ft)
3/8" UNF BOLT P/N B0620F CLUTCH SHAFT ONLY	35Nm (26lbf ft)
6mm BOLT/NUT	9Nm (80lbf in)
8mm BOLT/NUT	30Nm (22lbf ft)
20mm NUT	100Nm (74lbf ft)
5/8" UNF NUT	100Nm (74lbf ft)

BATTERY MAINTENANCE-

When not in use, a battery discharges by as much as 1% a day, more when the climate is warm. To make up for this loss, a boosting charge should be given once a month. Disconnect battery terminals to charge, then allow to stand minimum 1/2hr before re-connecting. If a battery is not used for a period of more than three (3) months, the terminals should be disconnected and trickle charged at two (2) amps for two (2) hours once every three (3) months or before use.

GREASE STUB AXLES -

Clean grease nipple, use grease gun and general purpose grease to force old grease from top and bottom of front axle bushes. Jack up front of machine if grease is not released from bottom of bush.

REMOVE MOWING

ATTACHMENT -

With engine off fully lower mowing attachment, and using spring hook and tommy bar supplied, disconnect the three springs below the front axle beam (warning, springs are under tension) remove attachment pivot rod. Disconnect rear lifting link, push attachment to the rear to loosen vee belt, remove vee belt from the rear pulley. Turn steering to full left hand lock and slide attachment from under machine to the right hand side. To refit, reverse the above procedure.

REPLACE P.T.O. TO CUTTER BELT -

Engage park brake, place mowing attachment in lowest position remove the front ends of the three springs from under front axle beam using spring hook and tommy bar supplied, (caution springs are under tension) remove R Pin from rear lifting link, disconnect link from mowing attachment and push mowing attachment to the rear to loosen belt. Remove belt from pulleys and replace with new belt, reverse the above procedure to re-tension belt.

REPLACE BLADES -

Stop engine. Remove spark plug lead. Lift windrower and raise cutter to highest position. If necessary simply remove the blade bolt and nut using a suitable spanner and replace all blades, bolts and nuts. For 40" mowing attachment it is advisable to remove mowing attachment for blade replacement. Tighten blade nut to (36-40Nm). Do not over-tighten.

CLUTCH PLATE ADJUSTMENT -

Start engine and run for approx 1 min at about half throttle, switch engine off, loosen the four square head set screws on the clutch plates using the tube spanner (AM006C1) and tommy bar (AM007). Insert the two clearance gauges supplied, one between the forward clutch plate and cone and the other in the reverse side and hook them onto the intershaft. Slide both clutch plates against the clearance gauges and clutch cone. Tighten the set screws firmly onto the flat machined on the intershaft. (Do not over-tighten set screws). Remove gauges.

Under no circumstances allow grease or oil to come into contact with the Clutch Cone or Clutch Plates. Should this problem occur, clean off immediately with petrol whilst surface areas are cool and allow to dry before operating machine.

REPLACE DRIVE CHAIN -

Engage park brake, jack up rear of machine, and remove L/H wheel. Push chain tensioner arms, one at a time, away from chain and using a suitable spanner tighten pivot bolt lock nuts to hold them out. Release park brake then turn rear axle to bring chain into a suitable position for removal of the chain connecting link. Remove connecting link and chain. Inspect both sprockets for wear or damage, replace if necessary. Install new chain and connecting link with the link clip between the wheel and chain. Release pivot arm nuts until arms move freely back to chain. Engage park brake, install wheel and lower machine.

SEAT ADJUSTMENT -

Pull seat adjustment lever to the left, then slide seat backwards or forward to desired position and release lever, ensure lever returns fully to right and seat is locked in position.

CLEANING AND POLISHING PLASTIC BONNET & FOOT PAN -

To keep scratches on bonnet to minimum, do not rub or brush off with bare hands, use a soft cloth or a light flow of compressed air. For dirt, wash with a steady stream of water only (no detergent), then blow off excess water with air. To polish remove excess dust or dirt. When surface is dry, spray on an automotive type plastic preservative and leave on for 30 to 60 seconds. Using a dry soft cloth (i.e. cheesecloth) wipe off to bring up lustre.

CLEANING MACHINE WITH WATER PRESSURE -

Allow machine to cool down (min 2 hrs) before hosing down. Start engine and engage drive and cutting systems to clear water from pulleys, belts and clutch areas. Stop engine and allow machine to dry. Lubricate as per lubrication chart before storage.

GENUINE SPARE PARTS -

Always use Genuine Cox Factory Made Spare Parts. Use of non genuine COX spares will void your warranty.

SAFETY FIRST -

The use of any mechanical appliance can cause injury if incorrect procedures are used. Please ensure that all family members of intended operators read this manual and safety instructions thoroughly.

We are proud that you have purchased a Cox product and urge you to follow these instructions to obtain the maximum life for your machine. If in doubt check with your supplier.

BODY COMPONENTS & TOOL KIT

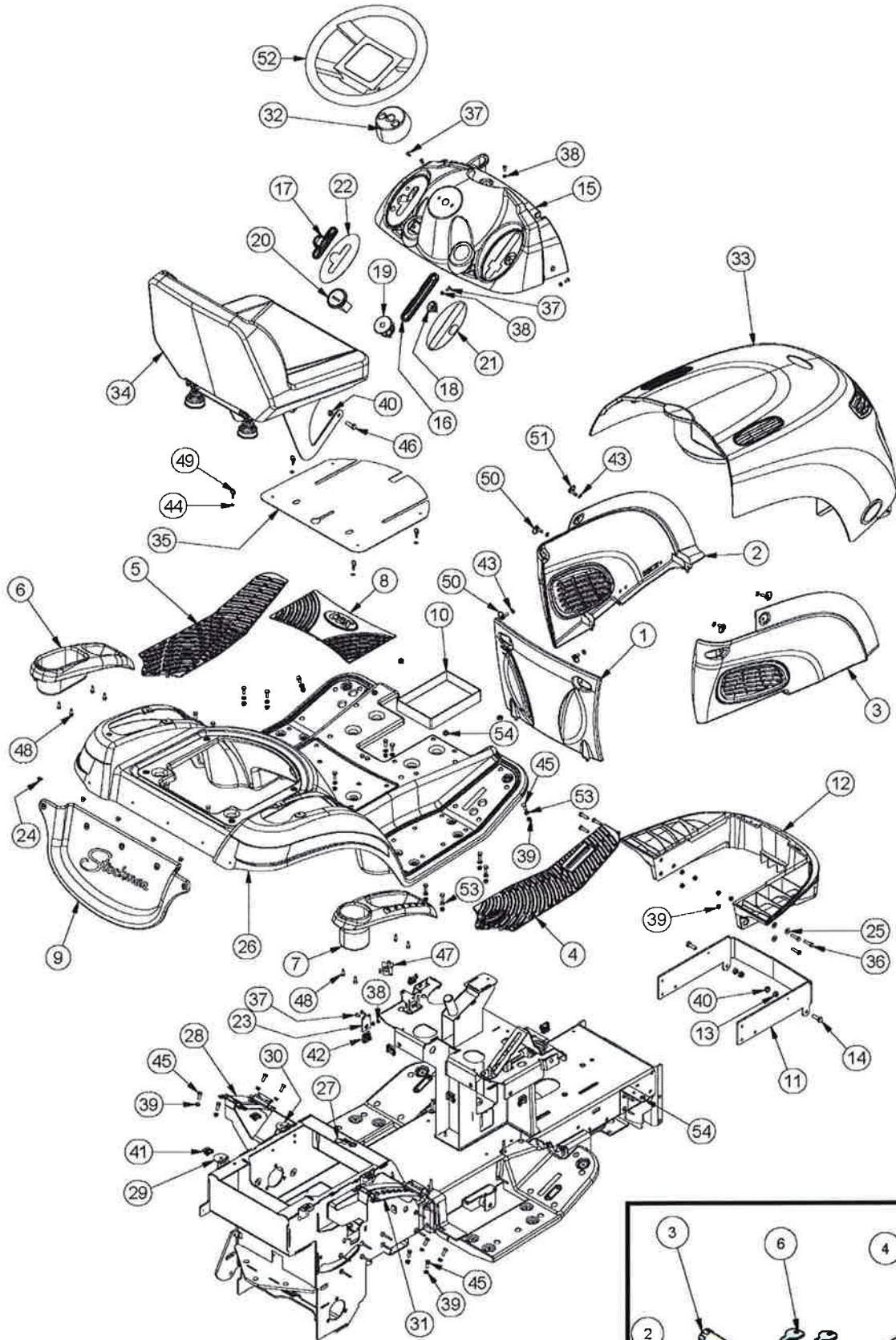

ITEM	PART NUMBER	TOOL KIT DESCRIPTION	QTY
1	AM006C1	Spanner, Tube, Clutch Plate	1
2	AM007	Bar, Tommy	1
3	AM295	Spanner, Tube, Spark Plug	1
4	13126	Gauge, Clutch Clearance	2
5	13127	Hook, Spring Pull	1
6	90134	Key, Ignition Switch	2

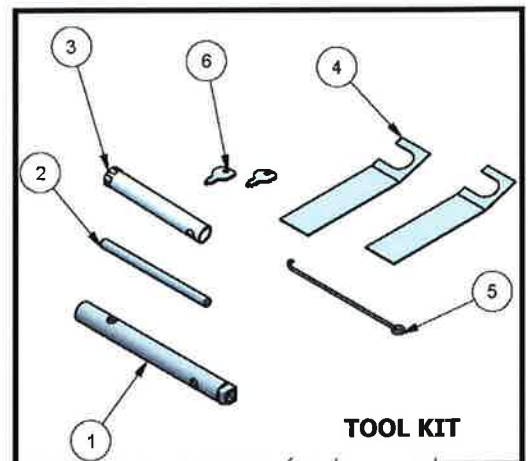

BODY COMPONENTS & TOOL KIT

ITEM	PART NUMBER	DESCRIPTION	QTY
1	A126233	Battery Cover	1
2	A126234	Left Side Cover	1
3	A126235	Right Side Cover	1
4	90045	Right Foot Mat	1
5	90046	Left Foot Mat	1
6	A126247	Hand Brake Shroud	1
7	A126248	Height Adjustment Shroud	1
8	90072	Centre Foot Mat	1
9	90075	Mud Flap	1
10	90076	Battery Spill Mat	1
11	A126220R	Support, Bumper Bar	1
12	A126270	Bumper Bar	1
13	NHM8	Nut	2
14	SH0825M	Screw	2
15	A126232	Dashboard	1
16	90063	Rubber Dash Insert, Disengagement	1
17	90064	Rubber Dash Insert, Throttle	1
18	90128	Switch, Light	1
19	90129	Ignition Switch	1
20	AM211	Hour Meter	1
21	DEC284	Decal, Cutter Slot And Light	1
22	DEC283	Decal, Throttle Control	1
23	90096	Console Lug	1
24	90132	Rivet, Plastic	5
25	90140	Bush, Bumper	6
26	90205	Pan, Foot, Plastic, Red	1
27	90251	Clip, Cover, Inspection, Top,	1
28	90258	Bracket, Lock, Handle, Park Brake	1
29	90259	Bracket, Clip, Tall	2
30	90260	Bracket, Clip, Short	2
31	A102038Z	Bracket, Adjust, Height, Cut	1
32	A102364	Adaptor, Console-Steering Wheel	1
33	A126385	Sub-Assy, Bonnet 16.5HP	1
	A126285	Sub-Assy, Bonnet 21HP	1
34		Sub-Assy, Seat+Adjuster+Hinge	1
35	A126447R	Cover, Inspection, Top	1
36	B0625M	Bolt	6
37	BHSSM5X12	Screw, Button	9
38	NM5NT	Nut	7
39	NM6NT	Nut	32
40	NM8NT	Nut	4
41	RECS4	Receptacle, 1/4 Turn, Clip-On, 4	4
42	RECS6	Receptacle, 1/4turn, Slip On, 6	6
43	RETP6	Retainer, 1/4turn, Plastic, 6	6
44	RETS4	Retainer, 1/4 Turn, Steel, 4	4
45	SH0616M	Screw	26
46	SH0825M	Screw	2
47	SP1PNOSM	Switch, Plunger	1
48	SPPK5X16	Screw, Pan	8
49	STDR414	Stud, 1/4 Turn, Bail, 4x14	4
50	STDR614	Stud, 1/4turn, Ring, 6x14	4
51	STDR622	Stud, 1/4turn, Ring, 6x22	2
52	SW14H	Wheel, Steering, 14"	1
53	W06MN	Washer, Flat	18
54	WG06x08	Grommet	6

BONNET COMPONENTS

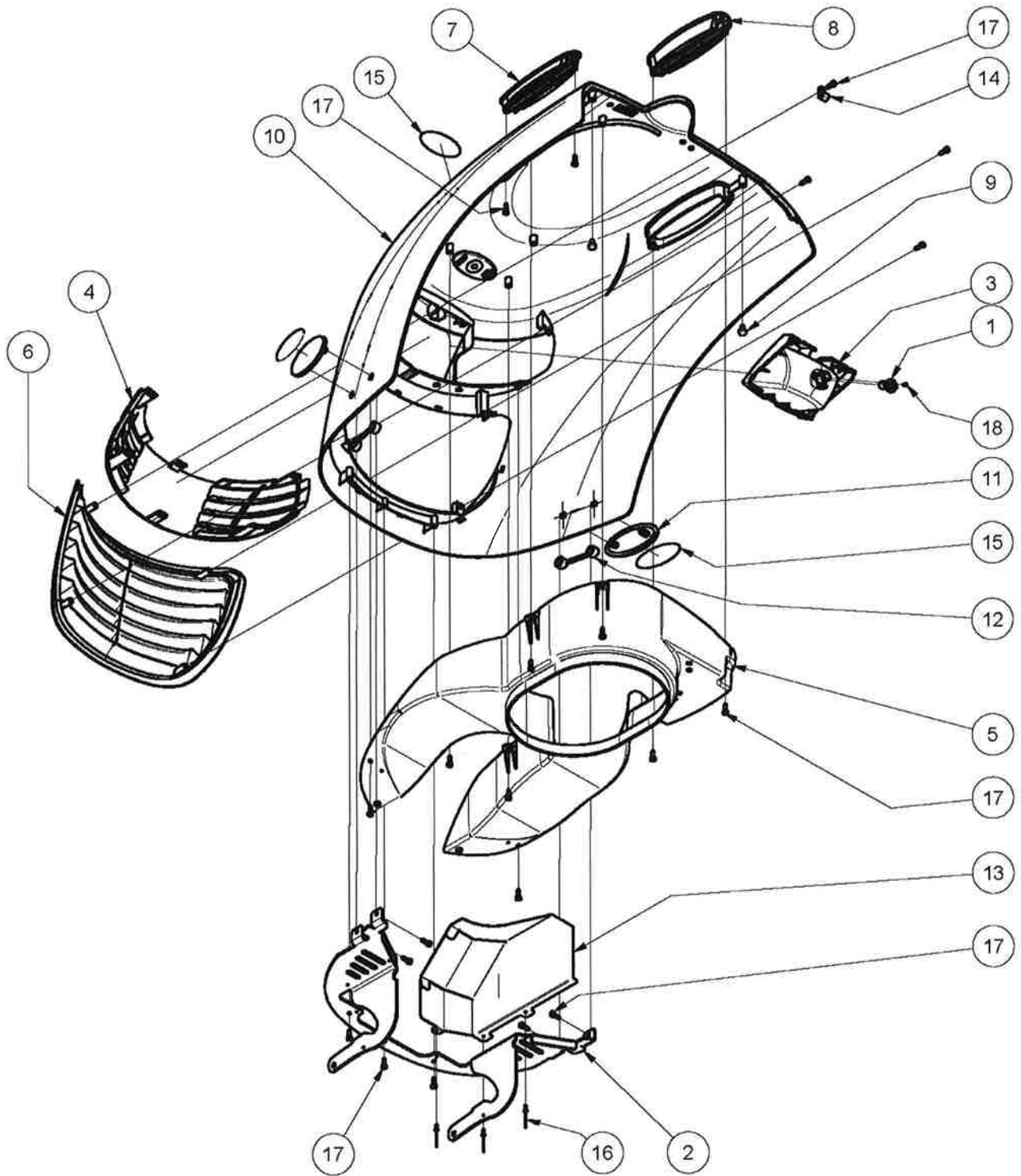

BONNET COMPONENTS

ITEM	PART NUMBER	DESCRIPTION	QTY
1	15132	Globe	1
2	A126221R	Hinge, Bonnet New Era	1
3	90038	Head Light Reflector	1
4	90039	Head Light Lens	1
5	A126240	Air Duct Intake	1
6	A126241	Grille	1
7	A126242	Left Bonnet Vent	1
8	A126243	Right Bonnet Vent	2
9	90130	Buffer, Rubber	2
10	9003108G	Bonnet incl Mountings and Spacers	1
11	A126044	Mounting, Side, Bonnet	2
12	A126045	Spacer, Mounting, Side, Bonnet	2
13	90147	Shield, Heat, Bonnet 16.5HP	1
	A126147	Shield, Heat, Bonnet 21HP	1
14	AM096	Clip	1
15	DEC180	Badge, Bonnet New Era	3
16	PR0207	Rivet, Heat Shield	3
17	SPPK5X16	Screw	22
18	SPST04CX0.37	Screw 18.5HP 21HP	1
	DEC276	Decal, Bonnet, Stockman PRO, LH	1
	DEC277	Decal, Bonnet, Stockman PRO, RH	1

SEAT COMPONENTS

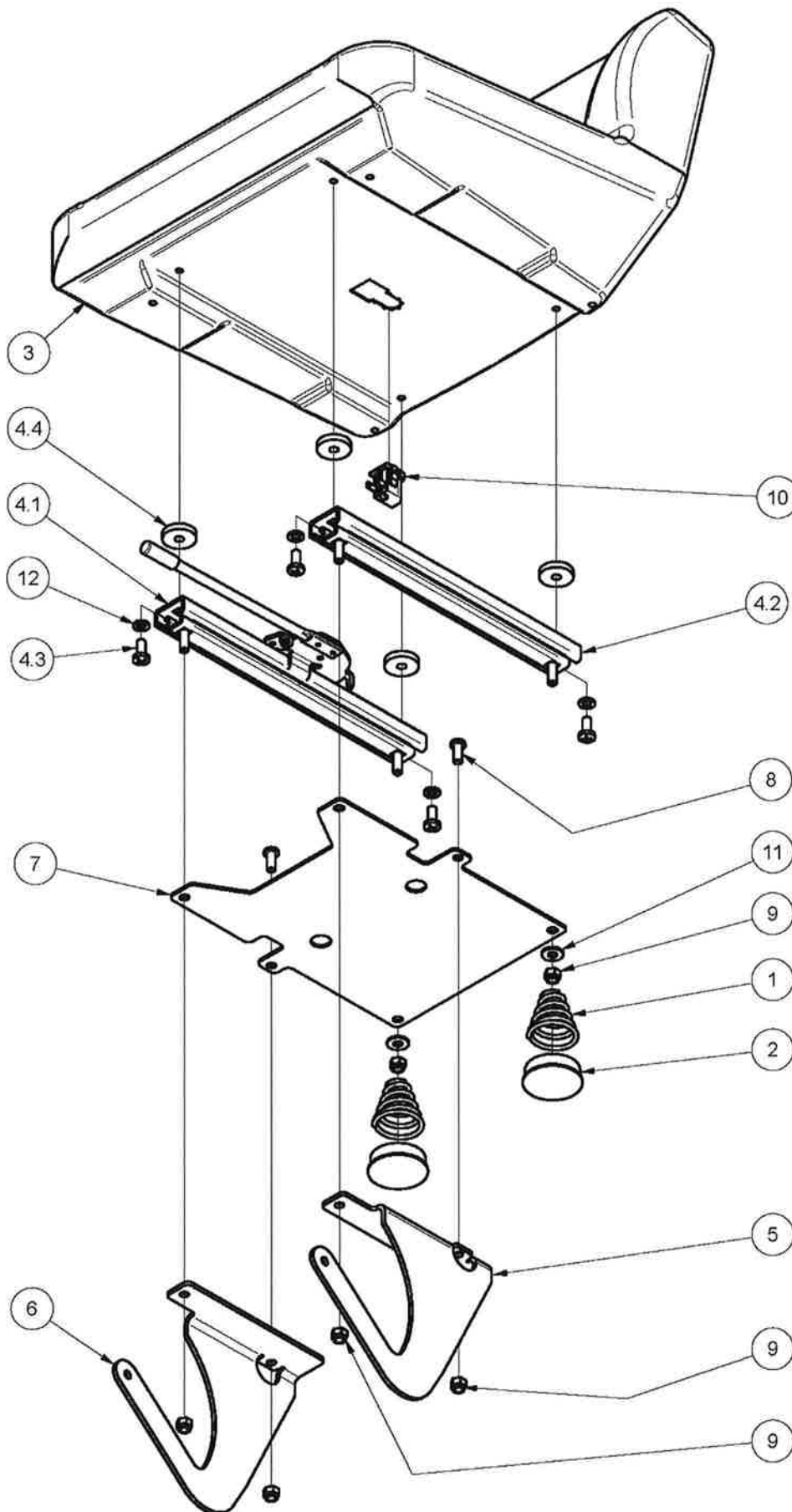

SEAT COMPONENTS

ITEM	PART NUMBER	DESCRIPTION	QTY
1	13060	Spring, Seat	2
2	14128	Cap, Seat Spring	2
3	A126050	Seat	1
4	A126052	Kit,Adjust,Seat,4" Travel	1
4.1		Adjuster	1
4.2		Runner	1
4.3	BHSSC0512	Replacement Screw	4
4.4	13247	Replacement Washer	4
5	A126442Z	Bracket, Hinge, Left	1
6	A126444Z	Bracket, Hinge, Right	1
7	A126449R	Base, Seat	1
8	BHSSC0512	Screw, Button	2
9	N05CN	Nut	6
10	SP1PNCSM	Switch, Plunger	1
11	W05M202	Washer, Flat	2
12	WS050216	Washer, Lock, Spring	4

ENGINE & CONTROL COMPONENTS

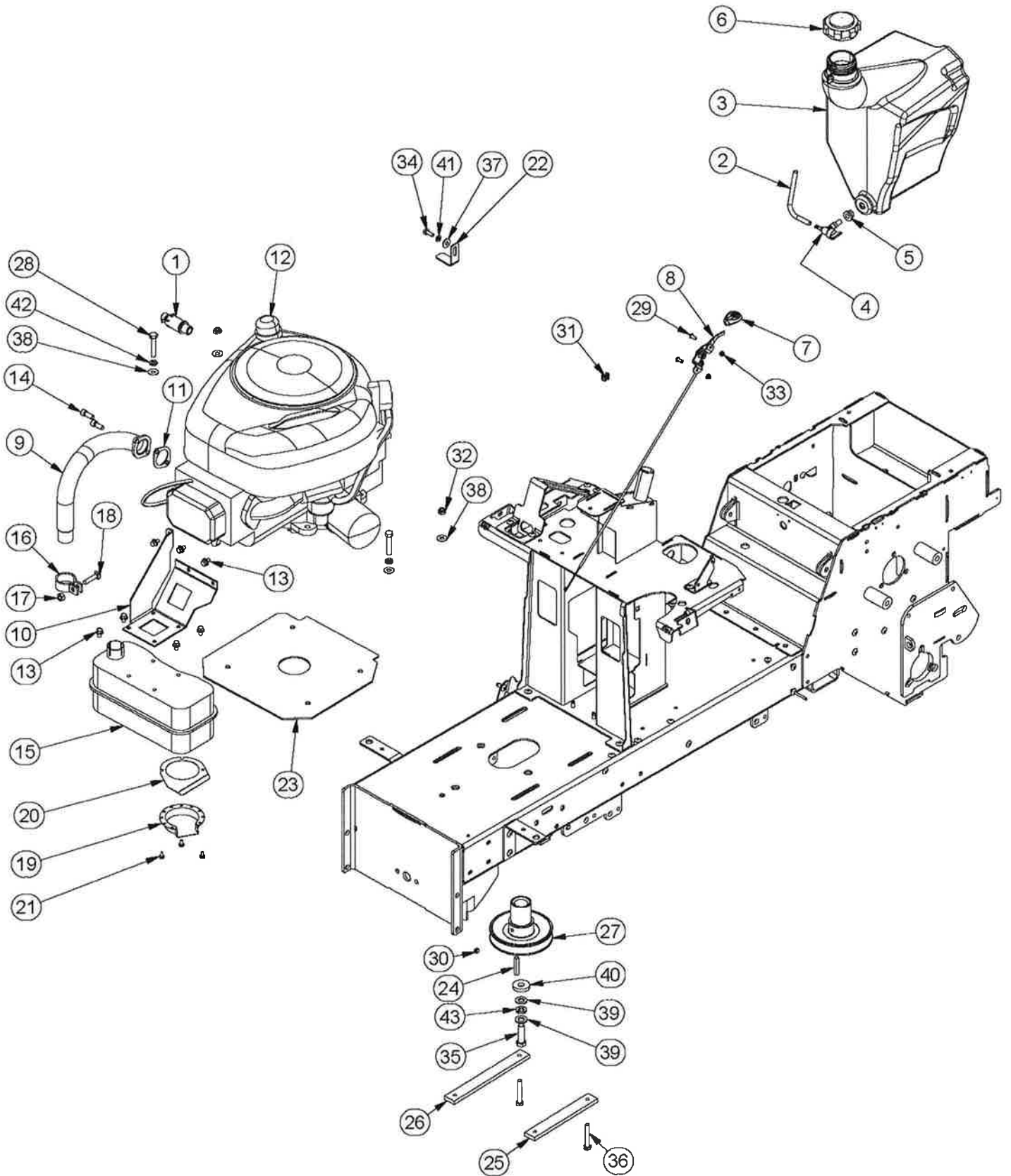

ENGINE & CONTROL COMPONENTS

ITEM	PART NUMBER	DESCRIPTION	QTY
1	13206	Valve, Drain, Oil	1
2	14107	Fuel Hose	1
3	90068	Fuel Tank	1
4	AM293	Petrol Tap	1
5	AM294	Grommet	1
6	CF01	Cap, Fuel	1
7	A126266	Throttle Control Handle	1
8	90078	Control, Throttle	1
9	13367	Exhaust Pipe	1
10	13368	Exhaust Bracket	1
11		Exhaust Gasket B&S	1
12		Engine	1
13		Screw	7
14	CHSS0512C	Screw, Cap	2
15		Muffler, Exhaust, B&S	1
16		Clamp, Muffler, B&S	1
17		Nut, Hex Mach, B&S	1
18		Bolt, Round Head Square Neck, B&S	1
19		Deflector, Muffler, B&S	1
20	80025	Deflector, Exhaust Gas	1
21		Screw	3
22	90139	Clamp, Battery	1
23	90295R	Plate, Base, Engine	1
24	A108104	Key	1
25	A116207Z	Plate, Mounting, Engine, Left	1
26	A116208Z	Plate, Mounting, Engine, Right	1
27	A126032	Pulley, Engine	1
28	B0845M	Bolt	2
29	BHSSM5X12	Screw, Button	2
30	GS0505C	Screw, Set	1
31	NCM6X1.6X9.5	Nut, Cage	1
32	NHCM8	Nut, Hex, Conelok	2
33	NM5NT	Nut	2
34	SH0616M	Screw	1
35	SH0724F	Screw	1
36	SH0850M	Screw	2
37	W041216	Washer, Flat	1
38	W051218	Washer, Flat	4
39	W071416	Washer, Flat	2
40	W072004	Washer, Flat	1
41	WS040816	Washer, Lock, Spring	1
42	WS050216	Washer, Lock, Spring	2
43	WS071008	Washer, Lock, Spring	1

WIRING DIAGRAM

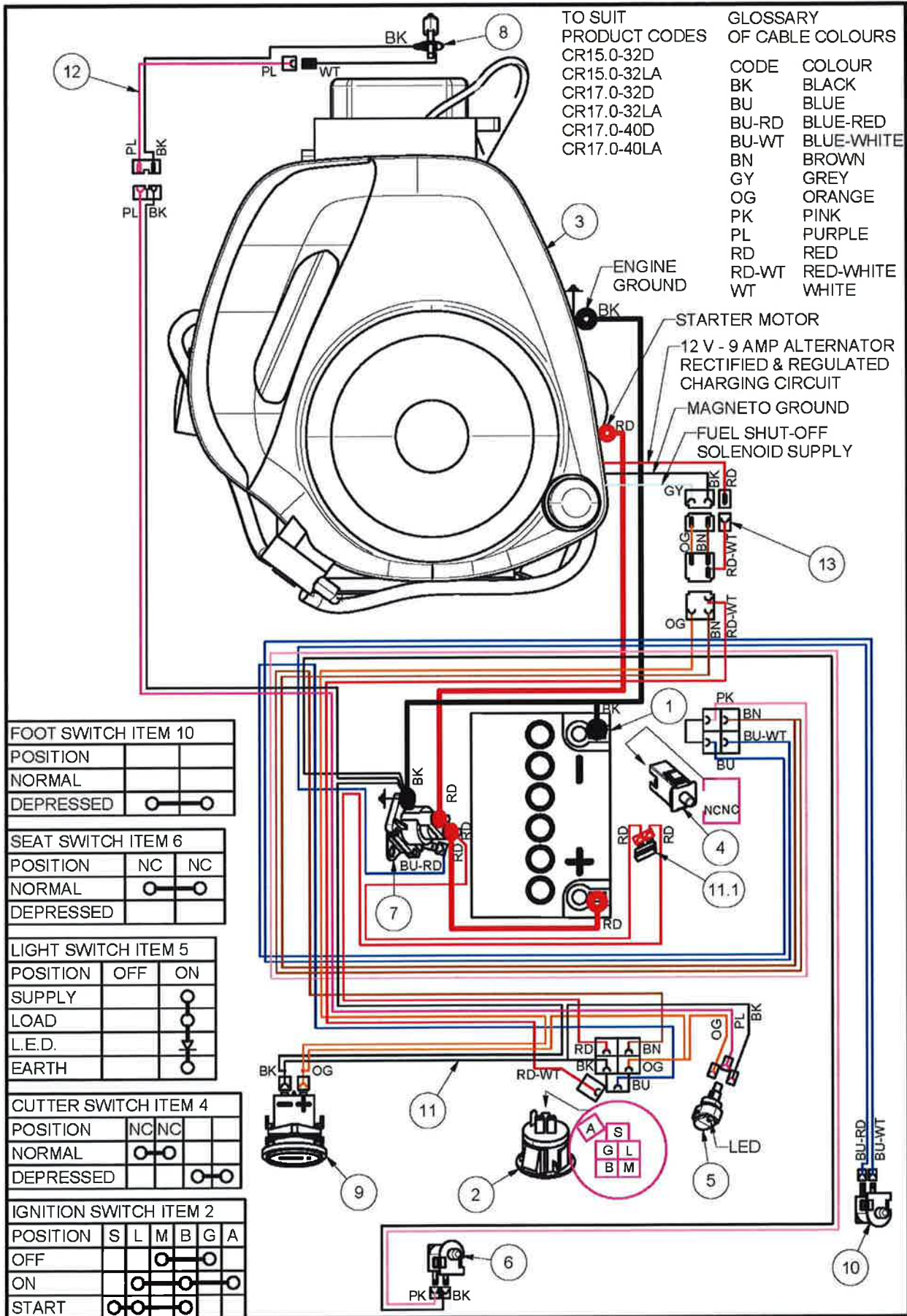

FOOT SWITCH ITEM 10

POSITION		
NORMAL		
DEPRESSED	○	○

SEAT SWITCH ITEM 6

POSITION	NC	NC
NORMAL	○	○
DEPRESSED		

LIGHT SWITCH ITEM 5

POSITION	OFF	ON
SUPPLY		○
LOAD		○
L.E.D.		○
EARTH		○

CUTTER SWITCH ITEM 4

POSITION	NC	NC
NORMAL	○	○
DEPRESSED		

IGNITION SWITCH ITEM 2

POSITION	S	L	M	B	G	A
OFF			○	○	○	○
ON		○	○	○	○	○
START	○	○	○	○	○	○

WIRING DIAGRAM

ITEM	PART NUMBER	DESCRIPTION	QTY
1		Battery (Purchase replacement locally)	1
	SH0620M	Screw, Battery	2
	NHM6	Nut, Battery	2
2	90129	Switch, Ignition	1
	90134	Key, Ign Switch	1
3		Engine	1
4	SP2PNONCSM	Switch, Plunger, Disengagement	1
5	90128	Switch, Light	1
6	SP1PNCSM	Switch, Plunger, Seat	1
7	AM159	Solenoid,	1
	SH0616M	Bolt, Solenoid	2
	NM6NT	Nut, Solenoid	2
8	15132	Globe	1
9	AM211	Hourmeter	1
10	SP1PNOSM	Switch, Plunger, Foot	1
11	90137	Harness, Wiring, Main	1
11.1		Fuse, Blade Type, 15 A, Blue	1
12	90138	Harness, Wiring, Headlight	1
13	13112	Harness, Wiring, Engine	1

BRAKE COMPONENTS

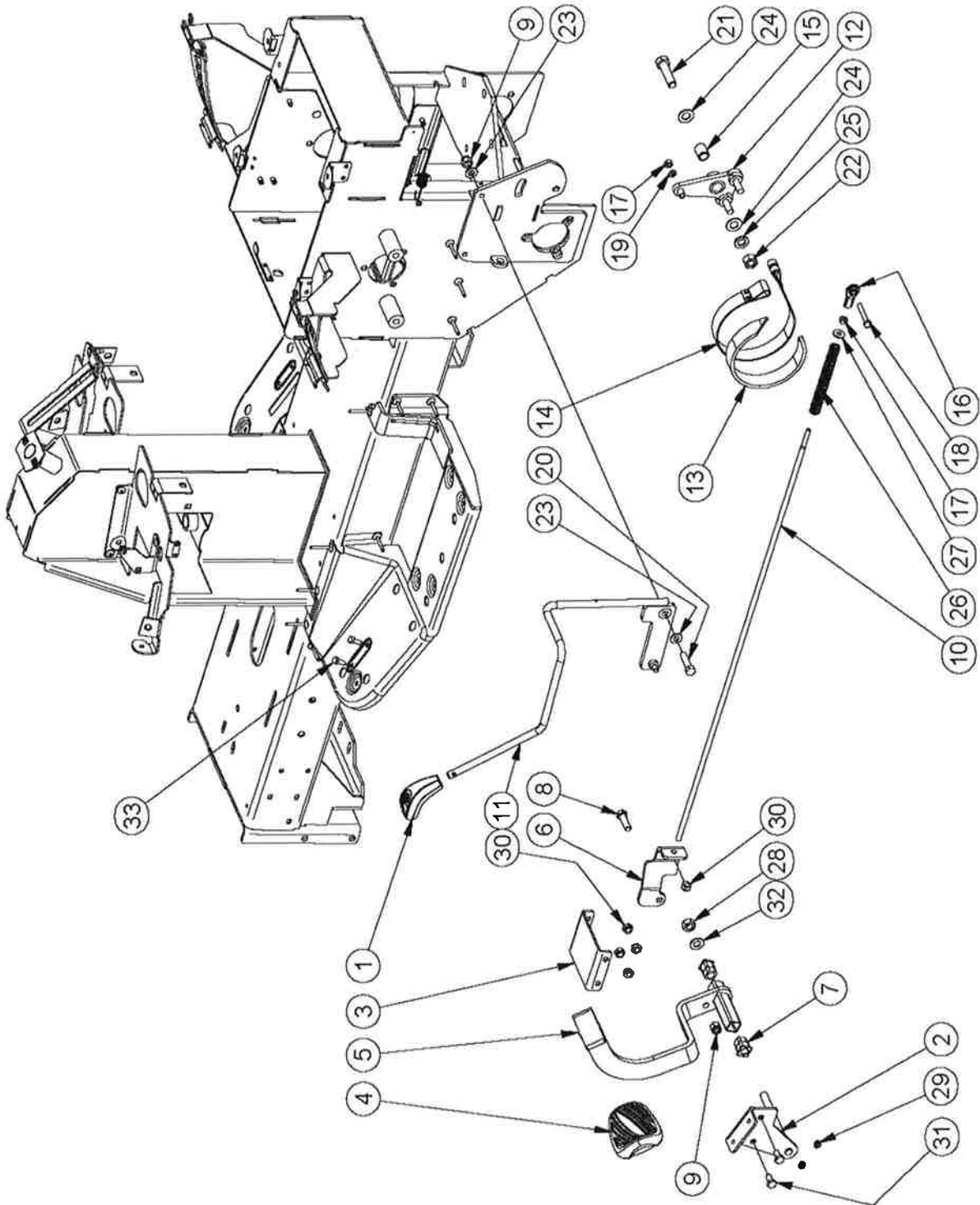

BRAKE COMPONENTS

ITEM	PART NUMBER	DESCRIPTION	QTY
1	A126262	Park Brake Handle	1
2	90264	Pivot, Brake Pedal	1
3	90219	Brace, Pivot, Brake Pedal	1
4	9007706D	Pad, Pedal, Brake	1
5	A126420R	Lever, Brake Pedal	1
6	90222	Link, Pull, Brake Rod	1
7	AM230	Bush - Plastic	2
8	B0620C	Bolt	1
9	NF06CN	Nut	2
10	90221	Rod, Brake	1
11	90024	Lever, Park Brake	1
12	9001506D	Lever, Brake, Actuating	1
13	13023-02	Lining, Band Brake	1
14	13023-0105E	Band, Brake	1
15	13025	Nylon Bush, Brake Lever	1
16	RE14INT	End, Rod, Stamp	1
17	N04F	Nut	2
18	B0428F	Bolt	1
19	WS040816	Washer, Lock, Spring	1
20	B0624C	Bolt	1
21	B0832C	Bolt	1
22	N08C	Nut	1
23	W061216	Washer	2
24	W081616	Washer	2
25	WS081208	Washer, Spring	1
26	13079	Spring, Compression, Foot Brake Return	1
27	W041216	Washer	1
28	N07F	Nut	1
29	NM6NT	Nut	2
30	NM8NT	Nut	5
31	SH0816M	Screw	4
32	W071416	Washer	1
33	SH0616M	Screw	2

STEERING COMPONENTS

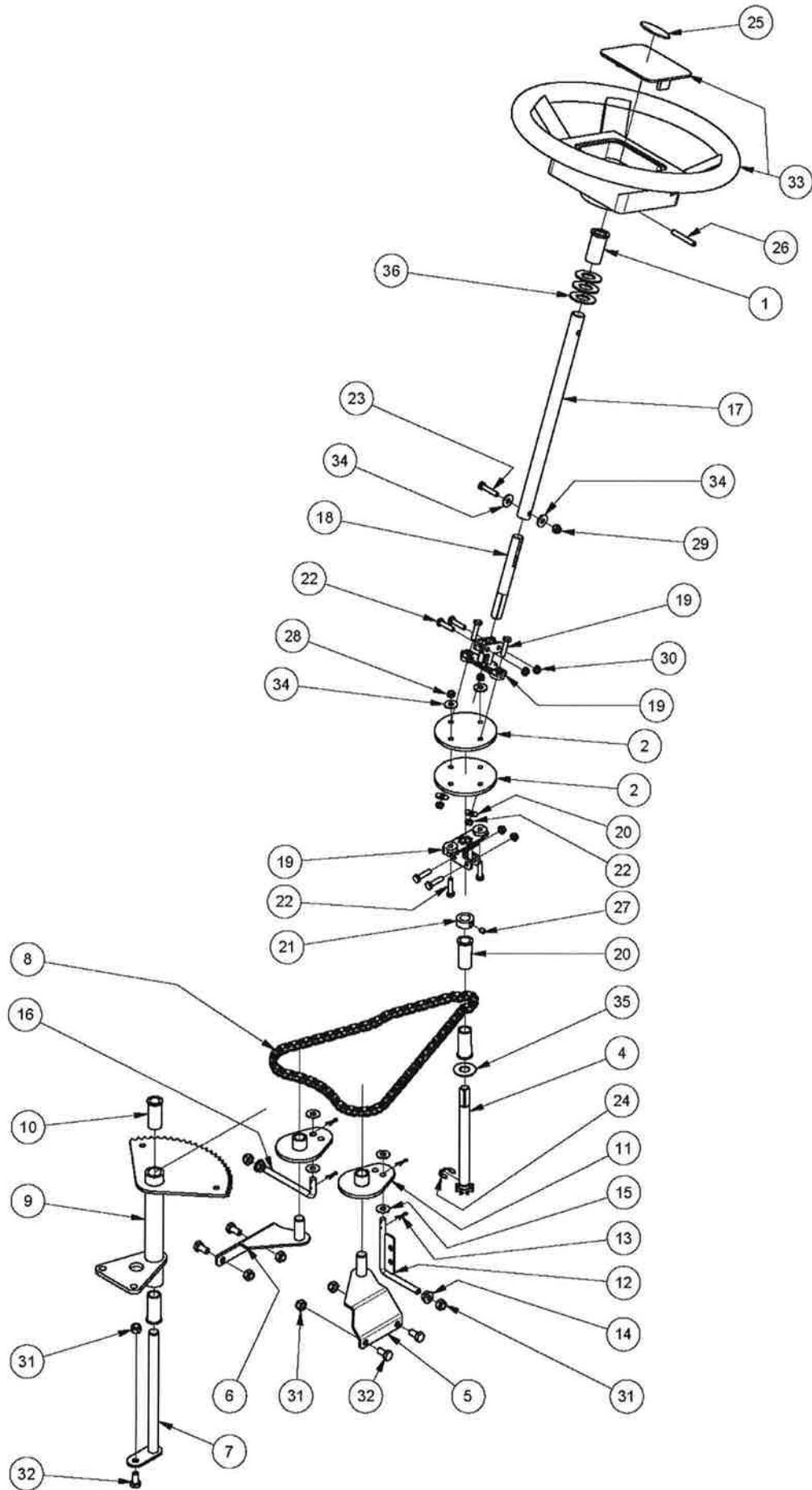

STEERING COMPONENTS

ITEM	PART NUMBER	DESCRIPTION	QTY
1	13012	Bush, Flanged, Nylon	1
2	AM25399J	Disc, Universal Joint	1
4	A126008Z	Shaft, Steering, Lower	1
5	A126018Z	Pivot, Idler, Left	1
6	A126020Z	Pivot, Idler, Right	1
7	A126024Z	Pivot, Crank	1
8	A126030	Chain, Roller	1
9	A126022Z	Crank, Steering	1
10	AM017C1	Steering Shaft Bush With Collar	2
11	A126016Z	Idler, Chain, Steering	1
12	A126026Z	Link, Adjust, Chain, Left	1
13	CP2-512	Pin, Split	2
14	NFM8	Nut, Hex, Flange, Serated	1
15	W051218	Washer	2
16	A126028Z	Link, Adjust, Chain, Right	1
17	A126165Z	Shaft, Steering, Top	1
18	A126167Z	Shaft, Steering, Upper	1
19	A126174Z	Yoke, Joint, Universal, Steering	2
20	AM017C1	Steering Shaft Bush With Collar	2
21	AM066	Steering Shaft Lock Collar	1
22	B0625M	Bolt	8
23	B0630M	Bolt	1
24	C05	Circlip, Ext, "E" Type	1
25	DEC177	Badge, Steering Wheel	1
26	DP10	Pin, Roll, Spring	1
27	GS0404C	Screw, Set	1
28	NHCM6	Nut	4
29	NM6N	Nut	1
30	NM6NT	Nut	4
31	NM8NT	Nut	7
32	SH0816M	Screw, Hex	5
33	SW14H	Wheel, Steering	1
34	W041216	Washer	6
35	W092016	Washer	1
36	W122414	Washer	3

FRONT AXLE COMPONENTS

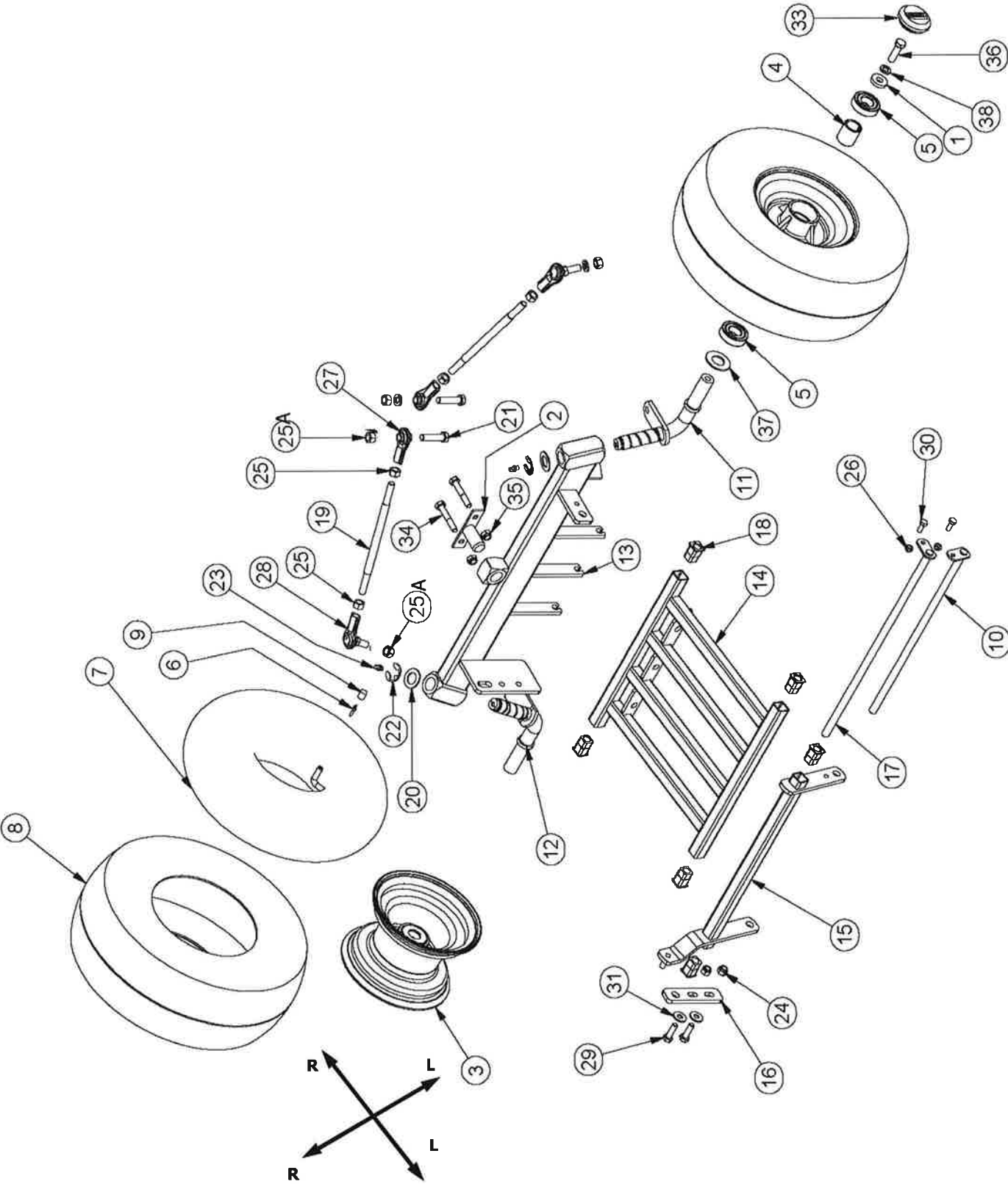

FRONT AXLE COMPONENTS

ITEM	PART NUMBER	DESCRIPTION	QTY
1	13107	Washer	2
2	13242	Pin, Pivot, Front Axle	1
3	13009	Rim	2
4	AM021	Sleeve, Spacer, Bearing	2
5	BB204212N	Bearing, Ball	4
7	STU600X6	Tube	2
8	TT600X698A	Tyre & Tube	2
10	13016	Pin	1
11	13203	Stub Axle Left Hand	1
12	13204	Stub Axle Right Hand	1
13	A142103R	Axle Beam, Front	1
14	A126204R	Link, Drag, Mowing Attachment	1
15	A126205R	Link, Cutter, Activation	1
16	90012	Connecting Link Adjuster Bracket	1
17	90022	Pin, Pivot	1
18	AM230	Bush - Plastic	6
19	A126036Z	Tie Rod	2
20	AM336	Washer, Sealing, Shaft	2
21	B0624F	Bolt	2
22	C02	Circlip, Ext, 'E' Type	2
23	GNTF3	Nipple, Grease	2
24	N05CN	Nut	2
25	N06F	Nut	4
25A	N06FC	Nut	4
26	NM6NT	Nut	2
27	AM377	End, Rod, Stamp	2
28	RE381NTSTUD	End, Rod, Stamp	2
29	SH0516C	Screw	2
30	SH0616M	Screw	2
31	W05M202	Washer	2
32	WS06081.5	Washer, Lock, Spring	2
33	AM07099C	Cap, Hub	2
34	B0850M	Bolt	2
35	NM8NT	Nut	2
36	SH0620F	Screw	2
37	W20MN	Washer	2
38	WS06081.5	Washer, Lock, Spring	2
	AM040	Spring	3

REAR AXLE COMPONENTS

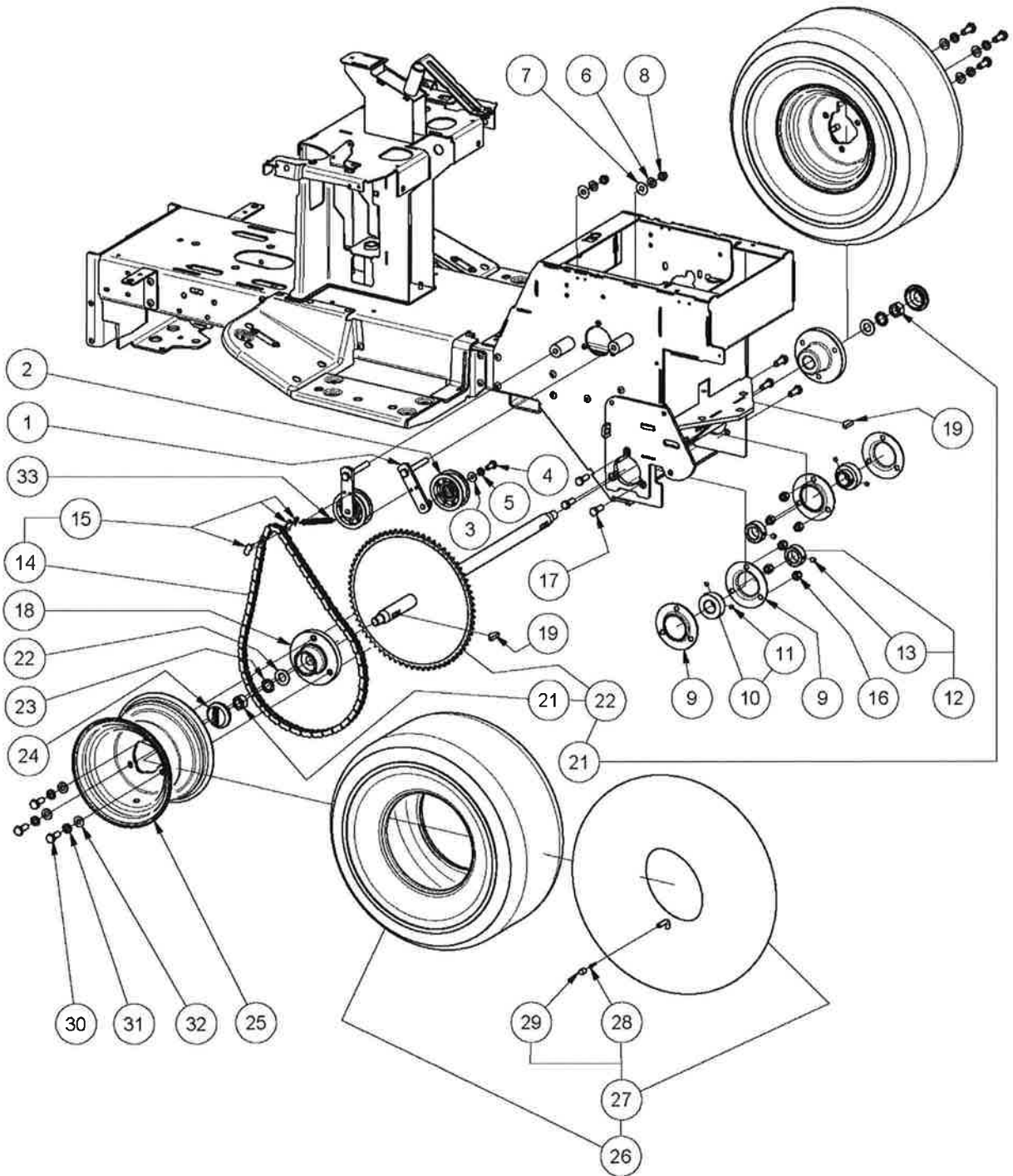

REAR AXLE COMPONENTS

ITEM	PART NUMBER	DESCRIPTION	QTY
1	A142362Z	Arm, Chain Tensioner	2
2	PIFBB126598A	Idler, Flat	2
3	W051218	Washer	2
4	SH0820M	Screw	2
5	WS050216	Washer, Lock, Spring	2
6	W061216	Washer	4
7	WW0616	Washer, Wave	2
8	NF06CN	Nut	4
9	AM024	Flangette	4
10	BB25SAN	Bearing, Ball	2
11		Screw, Set, Hex Soc, M 6x0.75x7	2
12	AM025	Lock Collar	2
13	GS0808M	Screw, Set	1
14	231901	Drive Chain Incl Con Link	1
15	S231904	Con Link	1
16	NF06CN	Nut	6
17	SH0616C	Screw	6
18	A138082	Adaptor, Wheel To Shaft	2
19	K18	Key	2
20	23190308J	Axle, Rear, Inc Nuts	1
21	N10F	Nut	2
22	W102015	Washer	2
23	W10S	Washer, Lock	2
24	AM07099C	Cap, Hub	2
25	AM305	Rim	2
26	TT850X8	Tyre & Tube	2
27	STU850X8	Tube	1
28		Core, Valve, Tr C1 Short	1
29		Cap, Valve	1
30	SH1025M	Screw	6
31	WSM10X3.7X2.5	Washer, Lock, Spring	6
32	W10MN	Washer	6
33	AM288	Spring, Extension	1

MODEL CA130: DIFFERENTIAL COMPONENTS

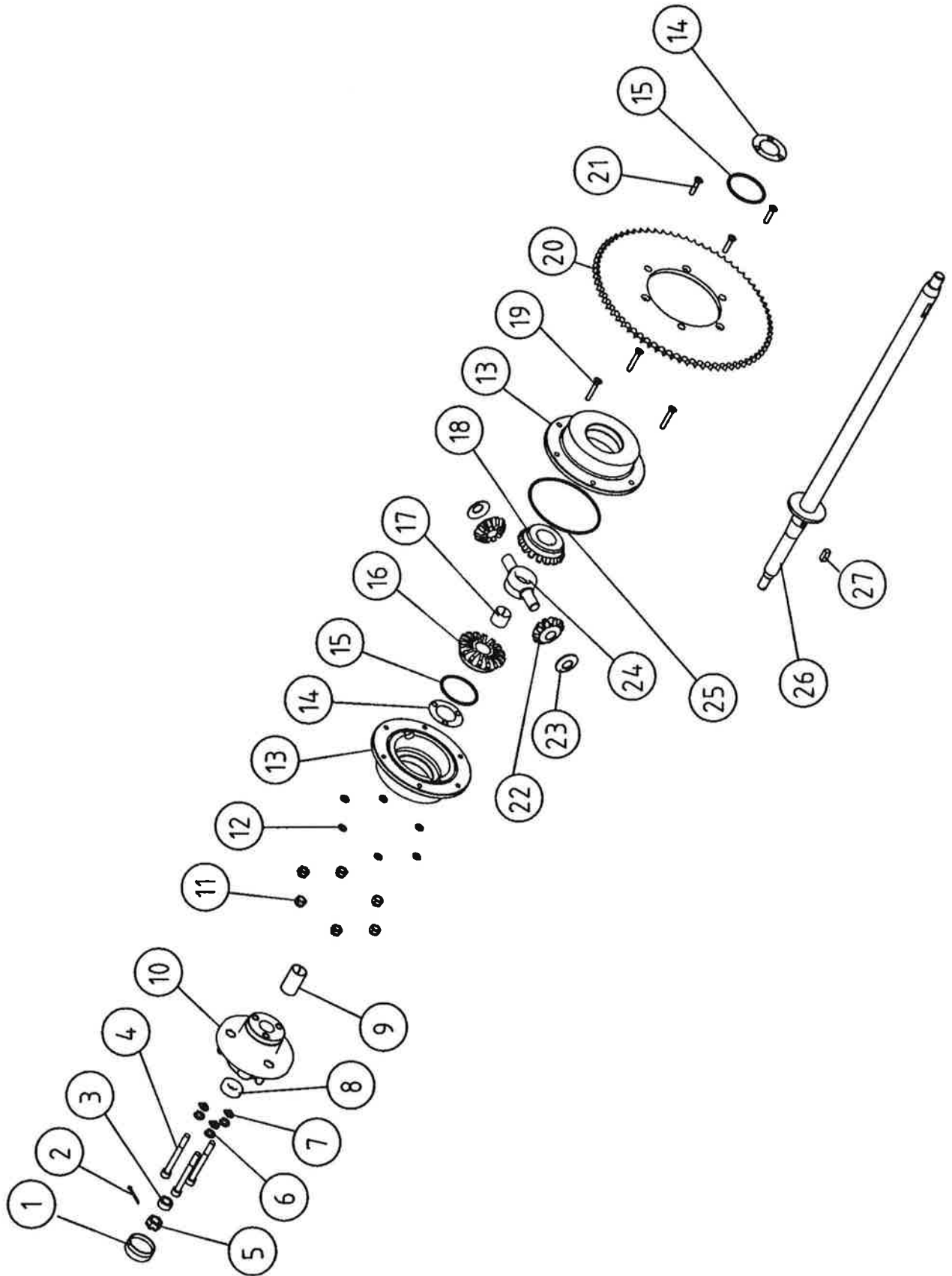

MODEL CA130: DIFFERENTIAL COMPONENTS (OPTIONAL)

ITEM	PART NO	DESCRIPTION	QTY
1	AM07099C	Hub Cap	1
2	CP3-225	Split Pin	1
3	AM340	Wheel Adaptor Sleeve	1
4	CHSBM8X75	Retaining Bolt	3
5	NS08F	Nut	1
6	WSM8X2X2	Spring Washer	3
7	AM324	Washer	3
8	BB15329N	Bearing	1
9	AM313	Bronze Bush	1
10	AM366	Adaptor Wheel	1
11	NM6NT	Nut	6
12	W06MN	Washer	6
13	AM3203L	Case, Plain Half	2
14	AM323	Gasket	2
15	AM319	O Ring	2
16	AM315	Drive Bevel Gear	1
17	AM314	Drive Bevel Gear Bush	1
18	AM306	Keyed, Bevel Gear	1
19	CSSSM6X25	Screw	3
20	AM321	Sprocket	1
21	CSSSM6X35	Screw	3
22	AM316	Gear, Bevel, Pinion	2
23	AM317	Thrust Ring	2
24	AM318	Pinion Yoke	1
25	AM325	O Ring	1
26	AM322	Axle	1
27	AM339	Gear Key	1

TRANSMISSION COMPONENTS

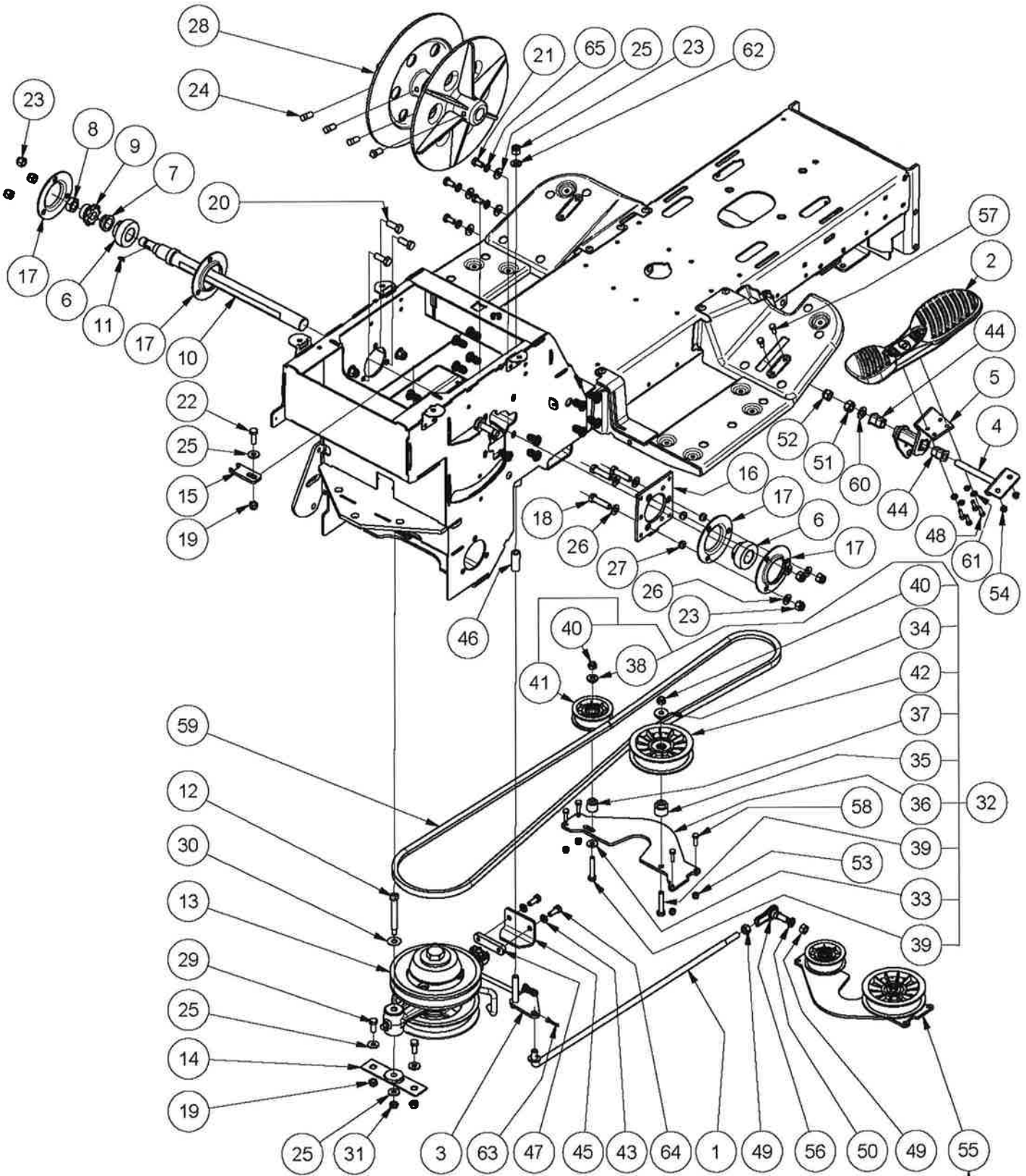

FOR 40" MOWING ATTACHMENT →

TRANSMISSION COMPONENTS

ITEM	PART NUMBER	DESCRIPTION	QTY
1	90013	Clutch Rod	1
2	90069	Clutch Pedal	1
3	9014806B	Crank, Link, Drive	1
4	90261	Pivot, Drive Pedal	1
5	A126463R	Lever, Drive Pedal	1
6	BB25SAN	Bearing, Ball	2
7	AM364	Sleeve, Spacer, Shaft	1
8	N10FT	Nut	1
9	SKIT65	Intershaft Sprocket & Key	1
10	AM363	Shaft, Mounting, Clutch Plate	1
11	SK03	Key	1
12	90276	Bolt, Pivot, Arm, Clutch	1
13		Sub-Assy, Clutch	1
14	90289	Mount, Pivot, Lower	1
15	90297	Keeper, Bolt, Pivot	1
16	90298	Mount, Adjust, Alignment	1
17	AM024	Flangette	4
18	B0624C	Bolt	3
19	NM8NT	Nut	3
20	SH0616C	Screw	3
21	SH0816M	Screw	4
22	SH0825M	Screw	1
23	NF06CN	Nut	7
24	SS0612W	Screw, Set	4
25	W05M202	Washer	4
26	W061216	Washer	6
27	WG06x08	Grommet	3
28	AM197	Clutch Plate	2
29	SH0820M	Screw	2
30	WW0616	Washer, Wave	1
31	NHCM8	Nut, Hex, Conelok	1
32	90291	Sub-Assy, Bridge, Idler, Front	1
33	W05M202	Washer	1
34	14025	Boss, Idler, 17dia, 3high	1
35	15176	Boss, Idler, 17dia, 17high	1
36	9029208E	Bridge, Idler, Rear	1
37	90293	Boss, Idler, 12dia, 16high	1
38	90294	Boss, Idler, 12dia, 3high	1
39	B0845M	Bolt	2
40	NM8NT	Nut	2
41	PIFB126598A	Idler, Flat, Flg, Brg, Sealed	1
42	PIFBB02	Idler, Flat, Flg, Brg, Sealed	1
43	WS050216	Washer, Lock, Spring	2
44	AM230	Bush	2
45	A126038Z	Bracket, Adjust, Support, Tang	1
46	AM328	Pivot Bush, Lever	1
47	A126170Z	Restraint, Tang, Small	1
	A126040Z	Restraint, Tang	1
48	CHSSM5X16	Socket Head Cap Screw	4
49	N06F	Nut	2
50	WS06081.5	Washer, Lock, Spring	1
51	N07F	Nut	1
52	N07FN	Nut	1
53	NM6N	Nut	4
54	NM6NT	Nut	2
55	90301	Sub-Assy, Bridge, Idler, Rear	1
56	RE38INTSTUD	End, Rod	1
57	SH0616M	Screw	2
58	SH0620MPC8	Screw	4
59	V50	Belt, V	1
60	W071416	Washer	1
61	WS05M	Washer, Spring	4
62	W061216	Washer	1
63	CP3-220	Pin, Split	1
64	SH0820M	Screw	2
65	WS050216	Washer, Lock, Spring	4

CLUTCH ARM COMPONENTS

ITEM	PART NUMBER	DESCRIPTION	QTY
1	A132013B	Arm, Clutch	1
2	BB205215NS	Bearing	2
3	AM072	Sleeve, Spacer, Bearing	1
4	AM204J3	Clutch Shaft	1
5	W205505B	Washer	1
6	A132015	Guide, Belt	1
7	A132017Z	Clamp, Guide, Belt	1
8	BCHSNM10X40	Bolt, Cup, Sq Neck	1
9	NM10NT	Nut	1
10	A132021Z	Retainer, Shoe	1
11	A132019H	Shoe	1
12	GS0830M	Screw, Set	1
13	NHM8	Nut	1
14	CC2095L	Cone, Drive	1
15	SK09	Key	1
16	PDM0630	Pin, Dowel	1
17	AM326	Clutch Pulley	1
18	25200109B	Pulley, Pto	1
19	WSCM20402.0	Washer, Spring, Conical	1
20	GNTF7	Nipple, Grease	1
21	A132025Z	Link, Drive, Short	1
22	A132027Z	Sleeve, Withdrawal, Link	1
23	CP3-220	Pin, Split	1
24	RP01	Pin, 'R'	1

CUTTER CONTROL COMPONENTS

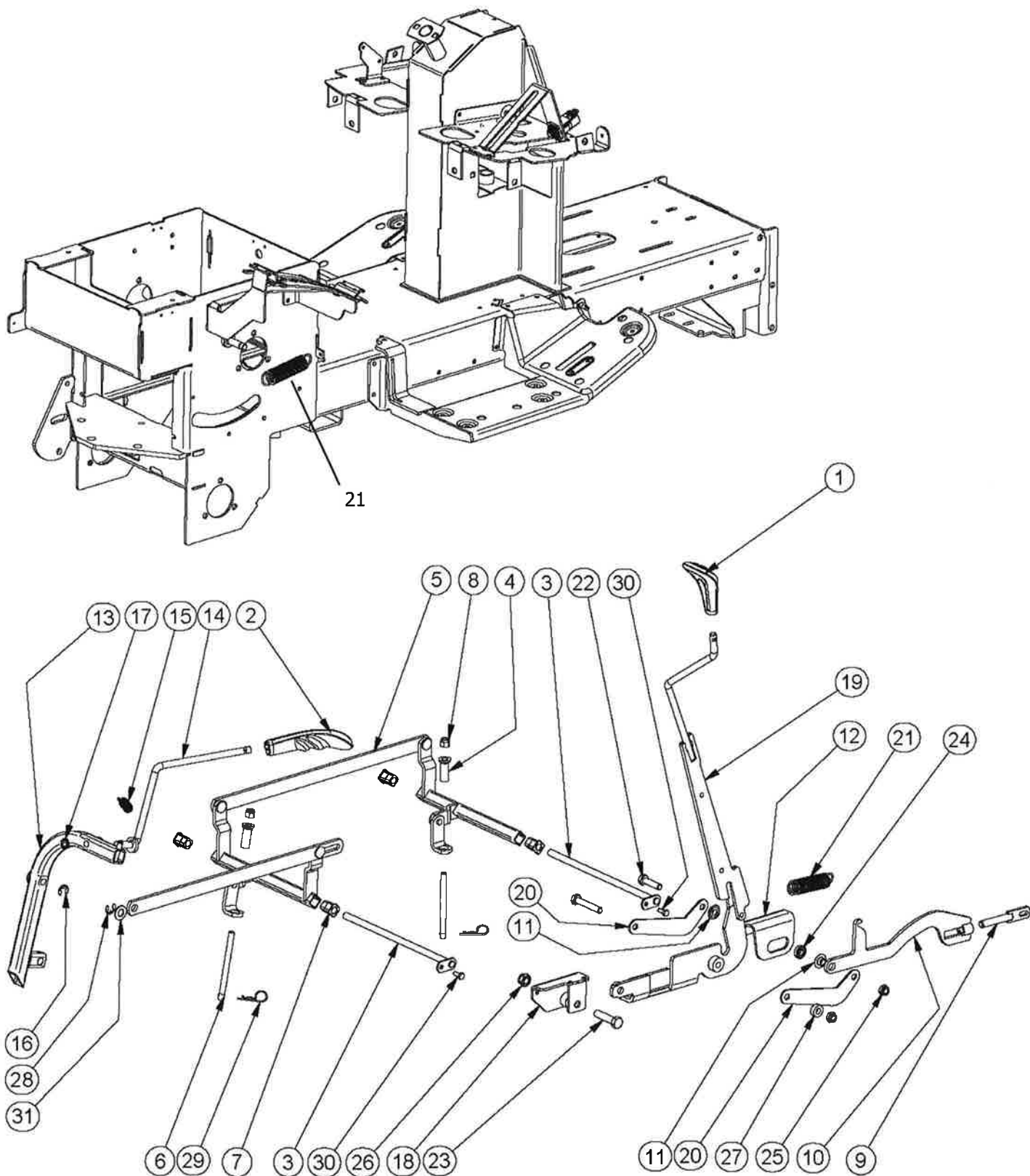

CUTTER CONTROL COMPONENTS

ITEM	PART NUMBER	DESCRIPTION	QTY
1	A126260	Disengagement Handle	1
2	A126261	Cutter Height Handle	1
3	13015	Pin	2
4	90229	Bush, Link, Adjust	2
5	9023006J	Mechanism, Link, Suspension, Mower	1
6	AM185B0	Cutter Lifting Link	2
7	AM369	Bush - Plastic	4
8	NF06CN	Nut	2
9	90231	Link, Adjust, Disengage	1
10	90232	Link, Bushed, Disengage	1
11	90233	Bush, Pivot, Disengage	2
12	90234	Bracket, Guide, Bearing	1
13	90240	Handle, Cutter Height Adjuster, Lower	1
14	9024107A	Lever, Cutter Height	1
15	90269	Spring, Extension, Return, Handle	1
16	C01	Retaining Washer	1
17	FPR10	Fastener, Push-on, Round	1
18	90257	Bracket, Pivot, Handle, Disengage	1
19	9026508C	Lever, Disengage	1
20	90266	Link, Bent, Disengage	2
21	AM145	Spring, Extension, Weight Compensating	2
22	B1040M	Bolt	1
23	B1250M	Bolt	1
24	BB102206N	Bearing, Ball	1
25	NM10NT	Nut	2
26	NM12NT	Nut	1
27	W102108	Washer	1
28	C01	Retaining Washer	1
29	RP03	Pin, "R"	2
30	SH0616M	Screw	2
31	W081616	Washer	1

32" MOWING ATTACHMENT COMPONENTS

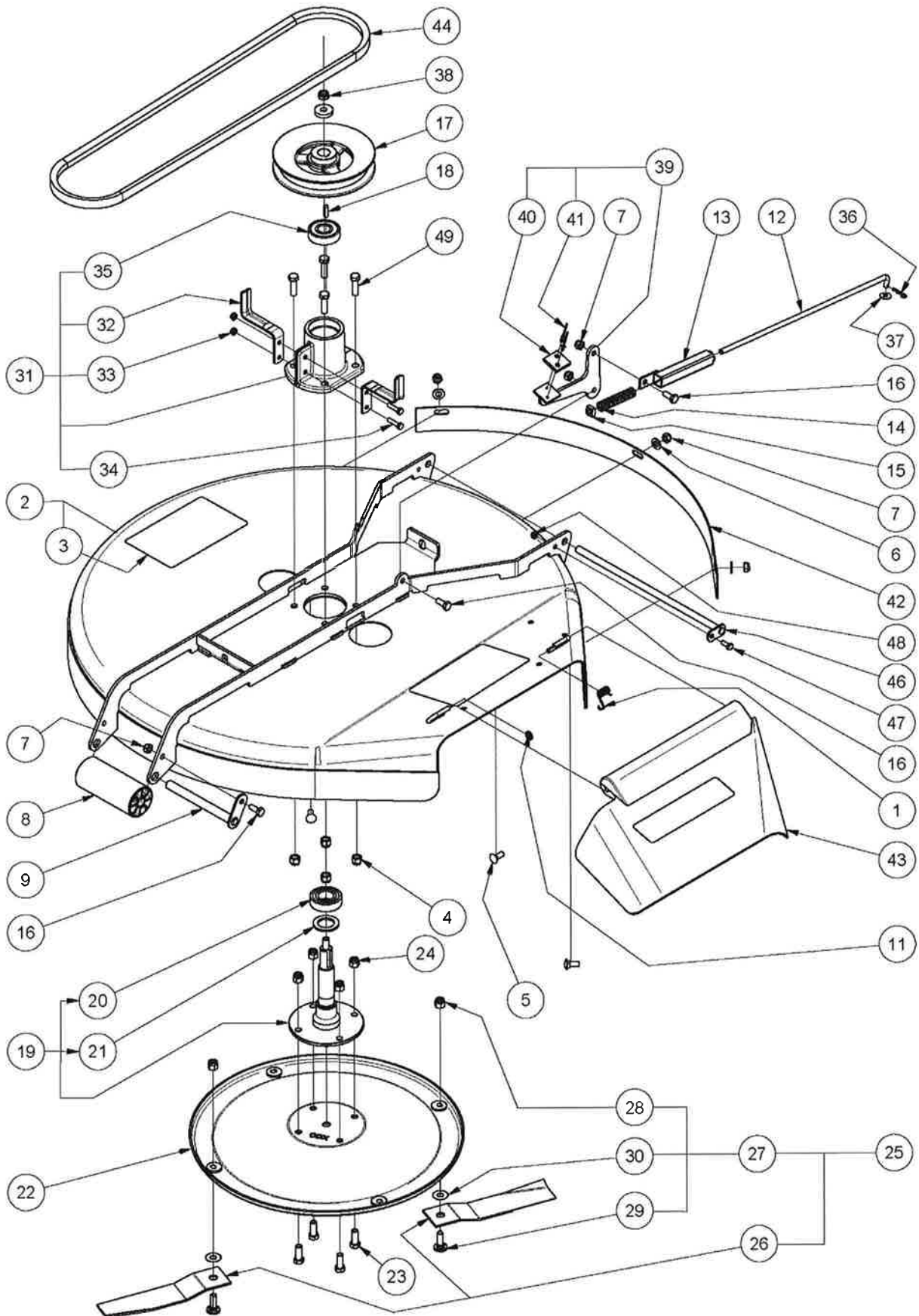

32" MOWING ATTACHMENT COMPONENTS

ITEM	PART NUMBER	DESCRIPTION	QTY
1	A100003	Spring, Torsion, Deflector	1
2	KIT226	Kit, Deck, Cutter, 805(32")	1
3	DEC116	Decal, Danger, Mowing Attachment	2
4	NF06CN	Nut	4
5	BCHSNM8X20	Bolt, Cup, Sq Neck	3
6	W061216	Washer	3
7	NM8NT	Nut	6
8	AM036D9	Roller Plastic	1
9	92102	Pin, Roller	1
11	AM274	Fastener, Push-on	1
12	251301	Rod, Adj, Cutter Brake	1
13	AM034H0	Cutter Head Brake Adj Brkt	1
14	AM035	Spring, Compression, Cutter Brake	1
15	NS05C	Nut, Sqr	1
16	SH0820M	Screw	3
17	A100017	Pulley, Cutter	1
18	A100025	Key	1
19	A113007	Sub-Assy, Spindle, Flanged	1
20	BB255215NN	Bearing, Ball	1
21	A100021Z	Washer	1
22	AM07604A	Disk, Cutter	1
23	SH0612C	Screw	4
24	N06CN	Nut	4
25	SKIT54N	32" HD Stepped Blade/Bolt/Nut Set	1
	SKIT55N	32" HD High Lift Blade/Bolt/Nut Set (optional)	
26	SMB198S	Stepped Blade [Set]	
27 ^(28,29,30)	SKIT01D1	Blade Bolt & Nut Set	
31	A113009	Sub-Assy, Housing, Bearing Cutter	1
32	AM073	Belt Guides	2
33	NM6NT	Nut	2
34	B0625M	Bolt	2
35	BB205215NS	Bearing, Ball	1
36	RP01	Pin, 'R'	1
37	W051218	Washer	1
38	NM10NT	Nut	1
39	A113010	Lever, Brake, Cutter	1
40	AM033I95	Pad, Brake, Cutter	1
41	PR0205	Rivet	2
42	93002	Guard, Cutter	1
43	AM259	Deflector	1
44	V45	Belt, V	1
45	13247	Washer	1
46	13016	Pin	1
47	SH0616M	Screw	1
48	NM6NT	Nut	1
49	B0620C	Bolt	4
	C94	Mulch Kit (Optional)	

40" MOWING ATTACHMENT MAIN COMPONENTS

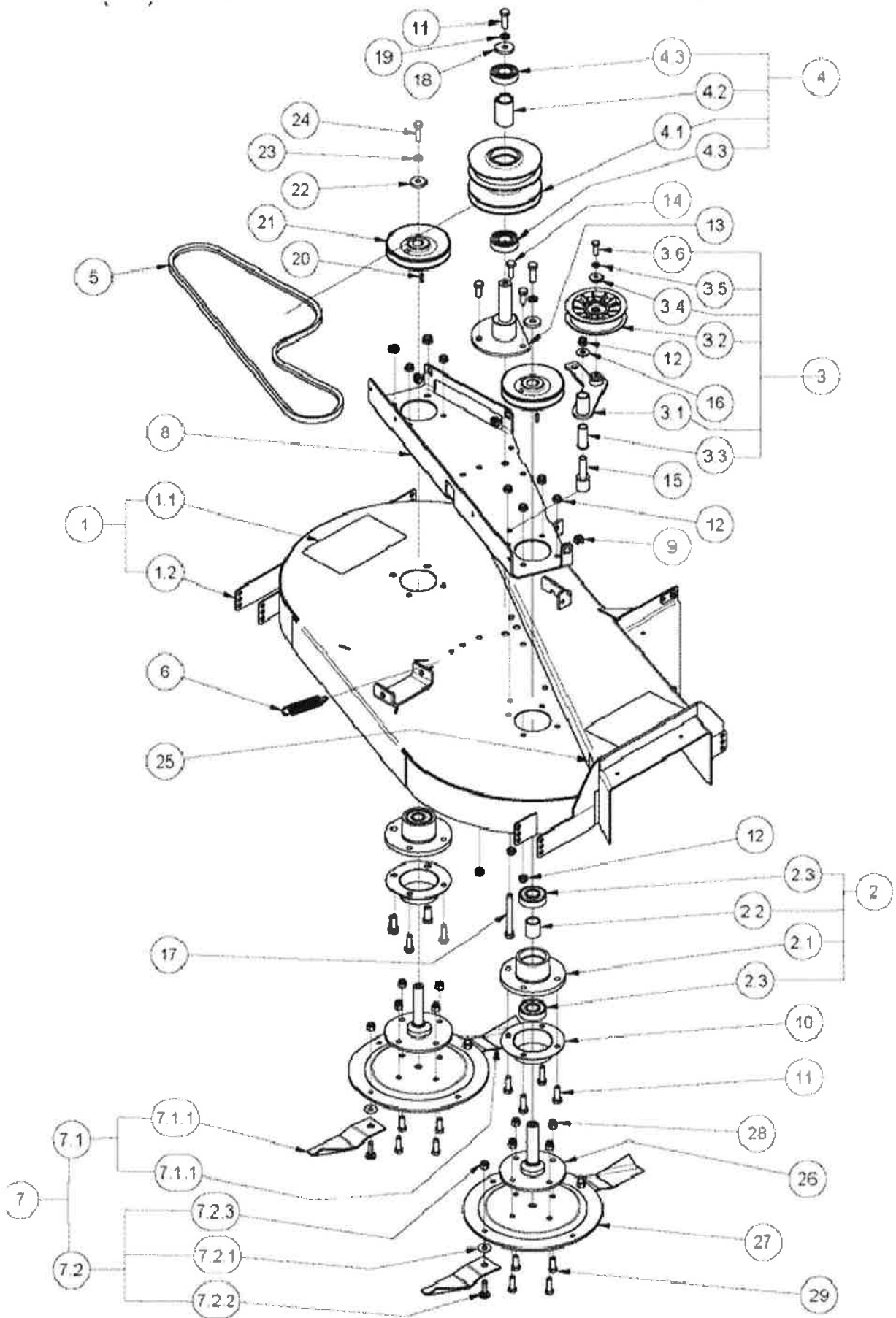

40" MOWING ATTACHMENT MAIN COMPONENTS

ITEM	PART NUMBER	DESCRIPTION	QTY
1	98201	Deck, Cutter (40"),	1
1.1	DEC116	Decal, Danger, Mowing Attachment	2
2	13298	Sub-Assy, Unit, Bearing, Flanged	2
2.1	AM242	Bearing Housing	1
2.2	AM021	Sleeve, Spacer, Bearing	1
2.3	BB205215NS	Bearing, Ball	2
3	98008	Sub-Assy, Tensioner, Belt	1
3.1	98006	Arm, Tensioner, Belt	1
3.2	PIFBB02	Idler, Flat	1
3.3	AM017C1	Steering Shaft Bush With Collar	1
3.4	14025	Boss, Idler	1
3.5	WS050216	Washer, Lock, Spring	1
3.6	SH0825M	Screw	1
4	98007	Sub-Assy, Unit, Bearing, Pulley	1
4.1	98010	Pulley, Transfer	1
4.2	98009	Sleeve, Spacer	1
4.3	BB255215NN	Bearing, Ball	2
5	V25	Belt, V	1
6	AM264	Spring, Extension Cutter Belt, Short	1
7	SKIT41N	Blade, Bolt, Nut& Washer Set (pr)	2
7.1	SMB137A	Blade Set (pr)	1
7.2	SKIT01D1	Blade Bolt, Nut & Washer Set (pr)	2
8	98202	Frame, Reinforce	1
9	NCM8X4.75	Nut, Cage	3
10	13240	Guard, Seal, Bearing	2
11	SH1030M	Screw	9
12	NM10NT	Nut	12
13	98003	Axle, Flanged	1
	98016	Plare, Flange	1
14	SH1025M	Screw	3
15	98005	Axle, Tensioner	1
16	W061602	Washer	1
17	B1090M	Bolt	1
18	W103506	Washer	1
19	WS103.52.2M	Washer, Lock, Spring,	1
20	AM271	Key	2
21	14003	Pulley, Cutter (40")	2
22	13247	Washer	2
23	WS06081.5	Washer, Lock, Spring	2
24	SH0620F	Screw	2
26	13239	Spindle, Cutter	2
	13128	Washer	2
27	14085	Disc, Cutter	2
28	NF06CN	Nut	8
29	SH0616C	Screw	8

40" MOWING ATTACHMENT ANCILLARY COMPONENTS

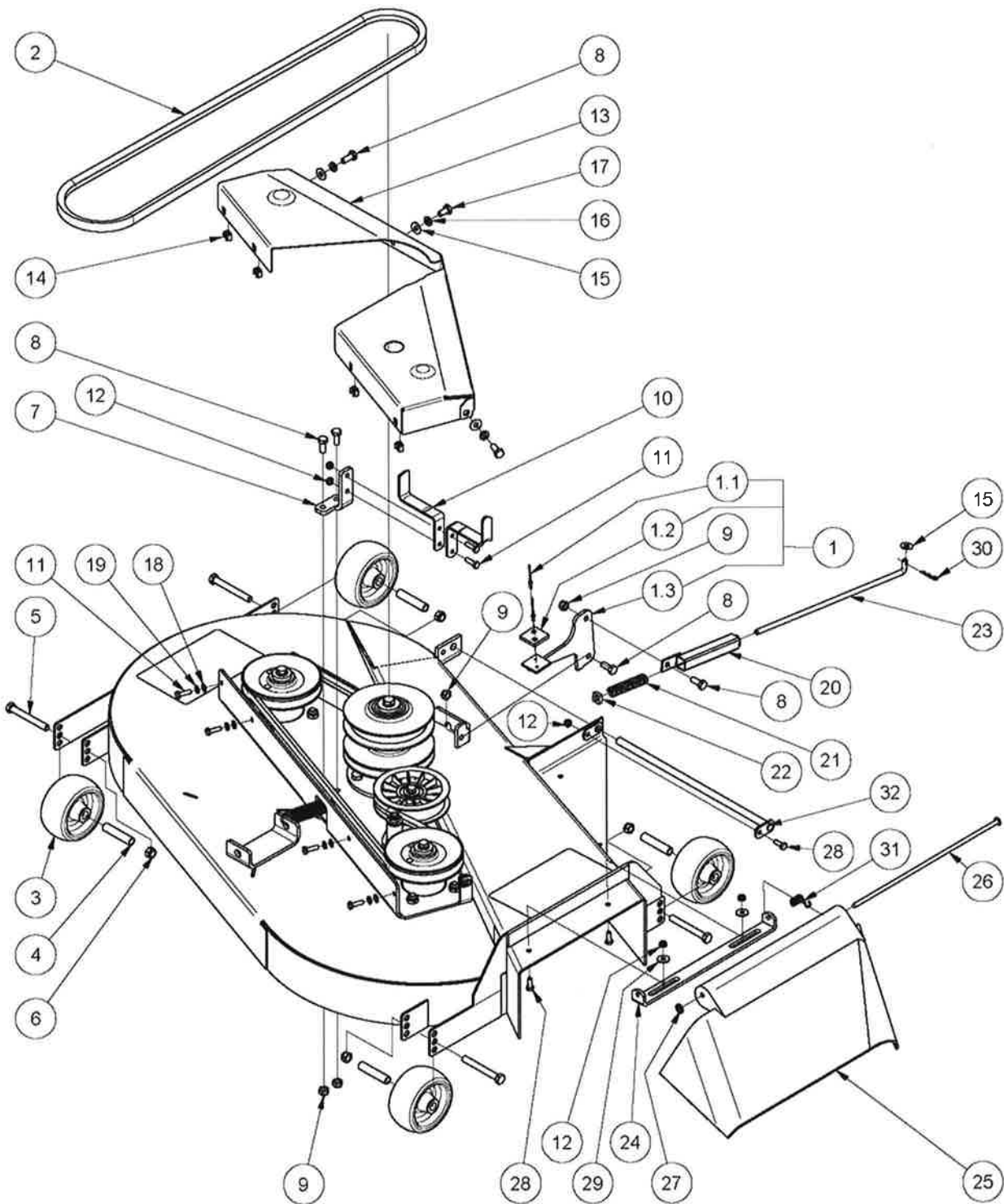

40" MOWING ATTACHMENT ANCILLARY COMPONENTS

ITEM	PART NUMBER	DESCRIPTION	QTY
1	98014	Arm, Brake, Cutter	1
1.1	PR0205	Rivet	2
1.2	AM033I95	Pad, Brake, Cutter	1
2	V43	Belt, V	1
3	AM25703H	Wheel	4
4	AM258	Flotation Wheel Bush	4
5	B0648C	Bolt	4
6	N06CN	Nut	4
7	98004	Bracket, Guide, Belt	1
8	SH0820M	Screw, Hex	6
9	NM8NT	Nut	4
10	AM073	Belt Guides	2
11	SH0620M	Screw	6
12	NM6NT	Nut	5
13	98212	Cover, Belt	1
14	NCM6x2.6x9.5	Nut, Cage	4
15	W051218	Washer, Flat	4
16	WS050216	Washer, Lock, Spring	3
17	SH0816M	Screw	1
18	W040818	Washer, Flat	4
19	WS040816	Washer, Lock, Spring	4
20	AM034H0	Cutter Head Brake Adj Brkt	1
21	AM035	Spring, Compression, Cutter Brake	1
22	NS05C	Nut, Square	1
23	091310	Rod, Adj, Cutter Brake	1
24*	AM052E1	Deflector Bracket	1
25*	AM259	Deflector	1
26*	AM273	Deflector Pivot Rod	1
27*	AM274	Fastener, Push on, Round	1
28	SH0616M	Screw, Hex	3
29	W041216	Washer, Flat	2
30	RP01	Pin, "R"	1
31*	AM272	Spring, Torsion, Deflector	1
32	13016	Pin	1

* SKIT66 Deflector Kit



COX INDUSTRIES WARRANTY POLICY

NEW MOWER:

COX INDUSTRIES warrants in respect of each new ride-on mower sold, that for a period of two (2) years (Domestic use**) or six (6) months Commercial/Contractors/Hire use***) to the original purchaser from the date of purchase, COX INDUSTRIES or an authorised dealer will repair or replace free of charge any ride-on mower parts found to be defective in materials or workmanship under normal use and operating conditions provided that:

1. The mower has been properly and reasonably used, operated, maintained and regularly serviced as per the maintenance schedule during the warranty period.
2. The replacement or repair is performed by an authorised COX INDUSTRIES Dealer.

** "Domestic/Consumer use" means the personal residential household (property use by the original retail purchaser.

*** "Commercial use" means all other uses, including income producing, rental, schools, government departments and charity operators.

PARTS INSTALLED DURING NEW MOWER WARRANTY PERIOD:

Warranty coverage for parts installed during new mower warranty period shall consist of the remainder of the new mower warranty period or ninety (90) days, whichever ever is greater, provided the installation is performed by an authorised COX INDUSTRIES Dealer.

ENGINE:

The engine in a new Mower is covered by the manufacturer of that specific engine, not by COX INDUSTRIES. Refer to the engine owners manual for details.

BATTERY:

The battery in a new mower is covered for a period of twelve (12) months by the battery supplier to the original purchaser from the date of purchase.

WARRANTY SERVICE :

In the event of a need for warranty service contact your local authorised COX INDUSTRIES Dealer. Date of purchase of machine must be given before warranty claim will be accepted for processing.

WARRANTY REGISTRATION:

The warranty registration card must be completed by the dealer with the customer at the time of purchase and returned to COX INDUSTRIES or an authorised Dealer within 14 days.

WARRANTY EXCLUSIONS:

- 1) The rental of another machine or related equipment while unit repairs are in progress.
- 2) Telephone, facsimile expenses or other related communication expenses.
- 3) Transportation and Insurance charges during transportation of failed unit or any part thereof.
- 4) The labour, parts, mechanical adjustments or lubricant costs which, in the judgement of COX INDUSTRIES or their authorised dealer, are made or should be made as standard maintenance according to the COX-INDUSTRIES maintenance schedule.
- 5) The replacement of normal maintenance parts such as (mower discs, blades, bolts and nuts, vee belts, bearings, chains and clutch cones) made in connection with normal maintenance services as opposed to manufacturing defects.
- 6) Any defect caused by alteration, modification, fitment of a non-genuine part or attachment not approved by COX INDUSTRIES.
- 7) Any defect caused by misuse, negligence, accidents or failure to carry out proper maintenance procedures.
- 8) Any defect caused by work carried out by other than an authorised dealer.
- 9) Damage caused by continued operation of the machine after it is known to be defective.
- 10) Damage caused by racing and similar activities or by overloading.

All implied warranties (save those preserved by statute) are excluded. Liability for consequential damages under any and all warranties are excluded to the extent exclusion is permitted by law.

To the extent that it is not prevented from doing so from statute, the manufacturer will not accept liability for costs of labour, postage, cartage or delivery to replace faulty materials or parts; or for any loss, damage or accident directly, indirectly, or consequently suffered by the purchaser, operator or any other person or property as a result of such faults whether due to defective materials or workmanship or otherwise

The careless or improper use of a machine of this type can be dangerous. The manufacturer or selling agent does not accept responsibility for accident either to the operator, to the owner or to any person directly or indirectly or to property if such accident is caused by circumstances arising other than by the negligence or default of COX INDUSTRIES.

Due to COX Industries on-going commitment to product improvement, we reserve the right to change at any time, product specifications, configurations and company policies.



Cox Industries (Australia) Pty Ltd

**70 Landseer Street
Acacia Ridge Qld 4110
Australia**

PH 07 3323 2222 FAX 07 3344 6233

Web Site Address: www.coxmowers.com.au

Email: sales@cox-mowers.com.au