

조립설명서

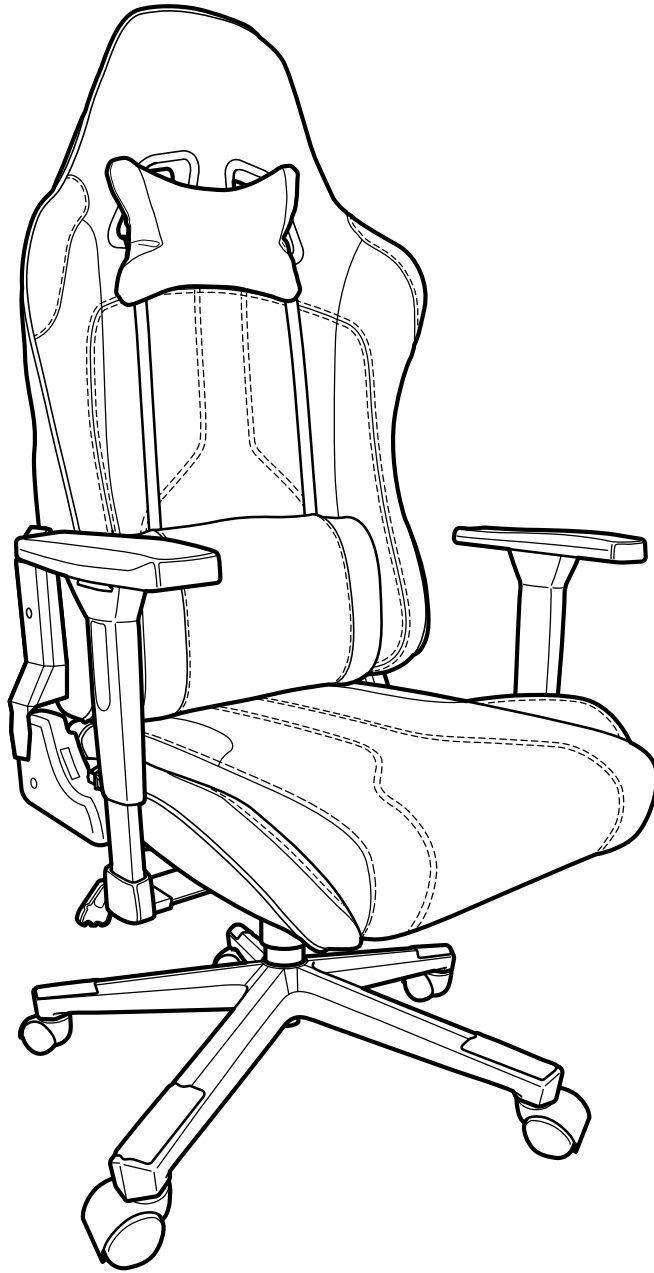

1인용



조립 2인이상

상 품 코 드 : 6620871 : BK/RE(블랙/레드)

상 품 코 드 : 6620872 : BK/GR(블랙/그린)

상 품 코 드 : 6620873 : BK/BK(블랙/블랙)

게이밍 의자 GM701

필요한 도구



조립시 주의사항 (모든 일러스트는 이미지입니다)

나사 조임 방법

나사는 처음부터 꼭 조이지 말아 주세요.

●처음부터 나사를 꼭 조이면 다른 나사의 구멍의 위치가 안 맞아 조립하기 어렵습니다. 또, 상품 전체의 뒤틀림의 원인이 됩니다.

1 모든 나사를 80% 정도만 조여 주세요

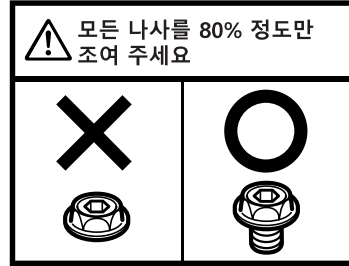

2 모든 나사를 완전히 조여 주세요.



대각선상에 있는 나사를 조이는 방법

- ① 최초의 나사를 임의의 장소에 설치하여, 그 대각선상의 위치에 두 번째 나사를 조여 주세요.
- ② 나머지 나사를 조여 주세요.

(예)

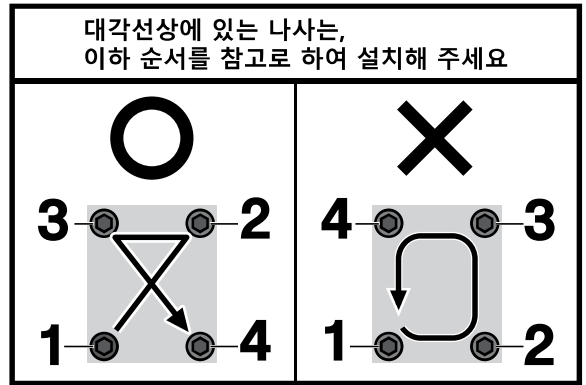

조립하기 전에 바닥을 보호해 주세요.

바닥을 보호하기 위해 그림과 같이 보호재를 본 상품 밑에 깔아 주세요.

- 두꺼운 수건
- 포장용 박스 등



부품

Ⓐ

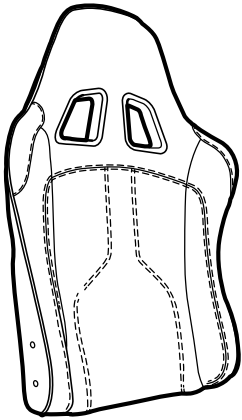

× 1

Ⓑ

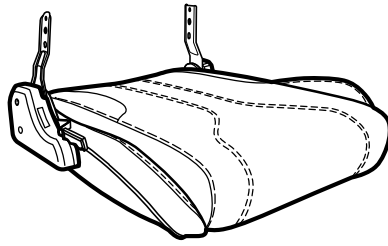

× 1

Ⓒ

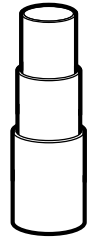

× 1

Ⓓ

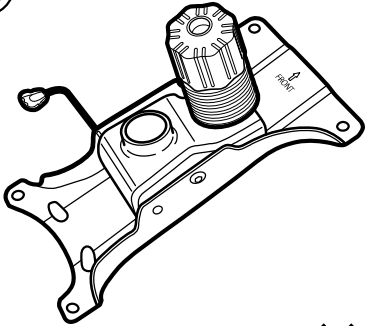

× 1

Ⓔ (우)



× 1

Ⓕ



× 1

Ⓖ

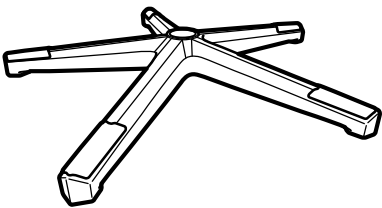

× 1

Ⓖ



× 5

Ⓚ

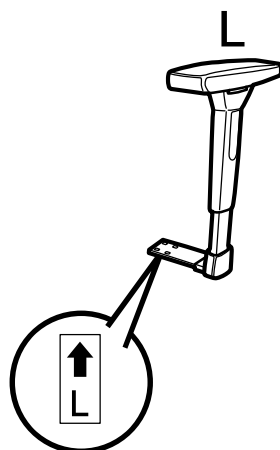
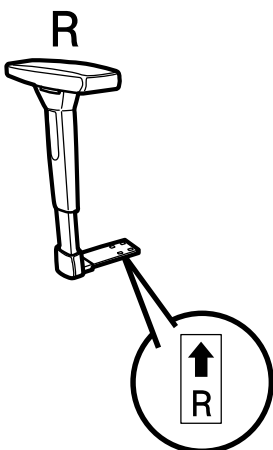

(좌우가 1세트)

× 1

부품

㉠

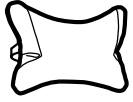

× 1

㉡ (좌)



× 1

㉢

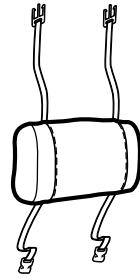

× 1

㉣ (25mm)

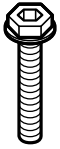

× 16

㉤ (16mm)



× 2

㉥ 나사 숨김 캡



× 2

㉦

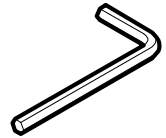

× 1

조립 방법

1

조립하기 쉽게 박스 등의 위에서 작업하면 훨씬 수월합니다.

⚠ 모든 나사를 완전히 조여 주세요

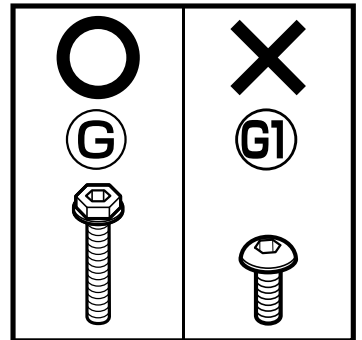
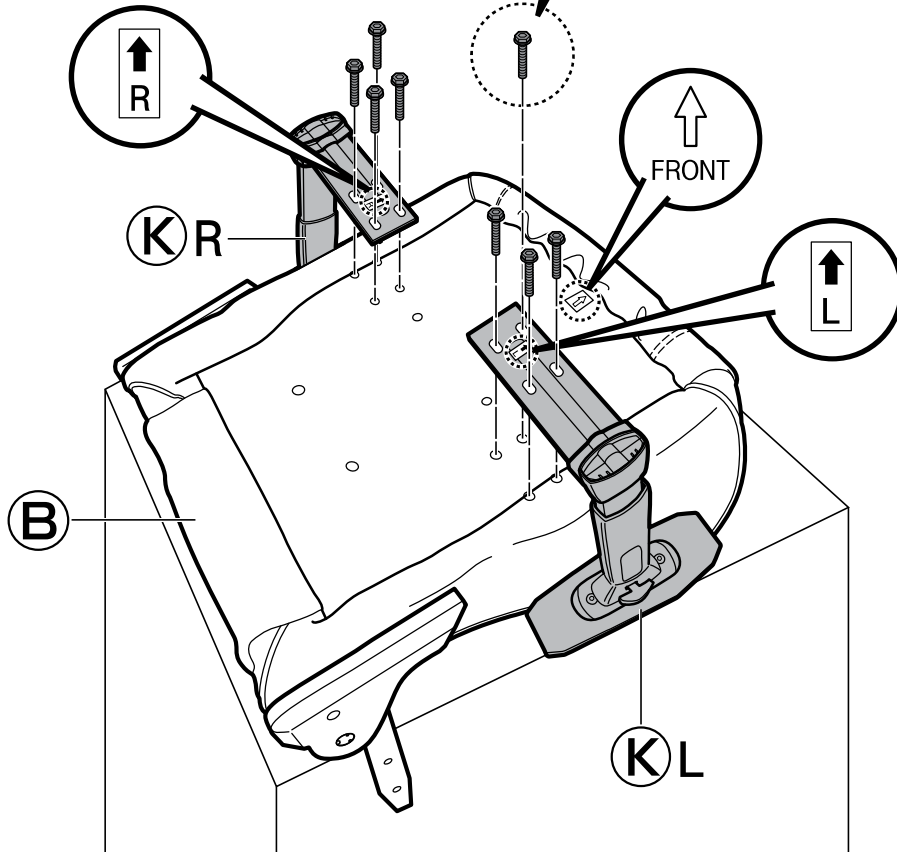
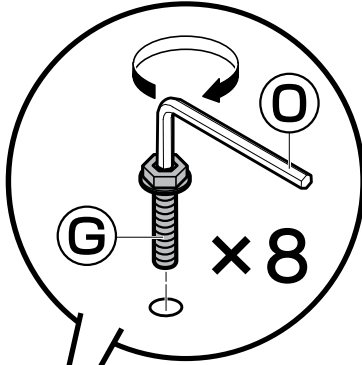
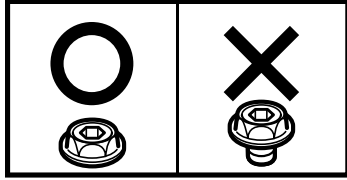

대각선상에 있는 나사는, 이하 순서에 따라 설치해 주세요

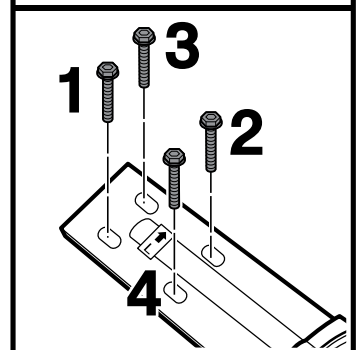

2

⚠ 모든 나사를 완전히 조여 주세요

○ 	✗
-------	-------

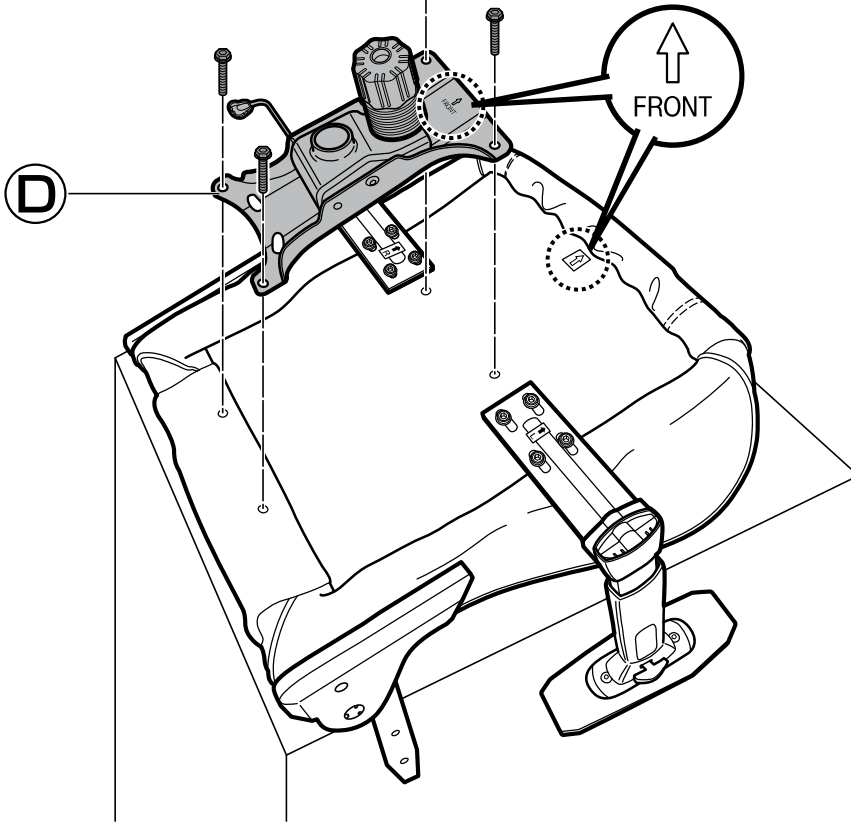
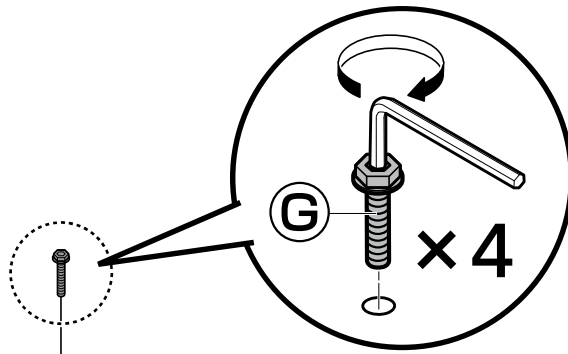

대각선상에 있는 나사는, 이하 순서에 따라 설치해 주세요

○ G 	✗ G1
------------	-------------

3

⚠ 바닥 보호재를 깔고 조립해주세요.
● 바닥을 상처내는 원인이 됩니다.

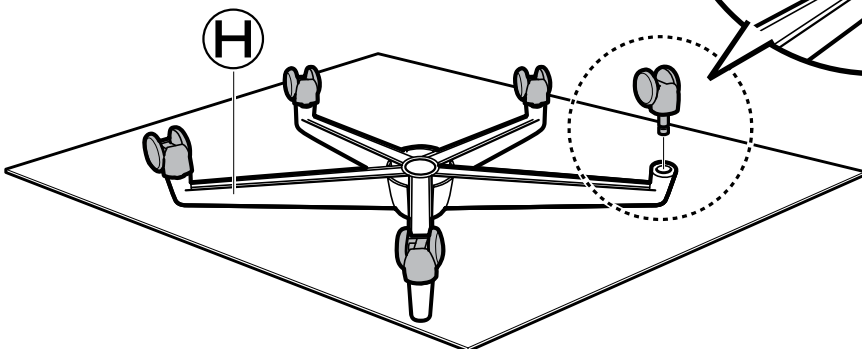
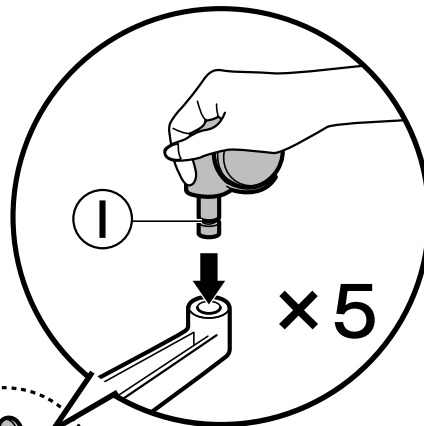

캐스터가 잘 끼이지 않을 경우, 수직으로 위에서 체중을 실어 힘을 가하면 잘 끼지게 됩니다.

○ 	✗
-------	-------

4

실린더[®]은, 윤활유가 발라져 있습니다.
손 또는 옷, 바닥 등이 더러워지지 않도록 주의해주세요.

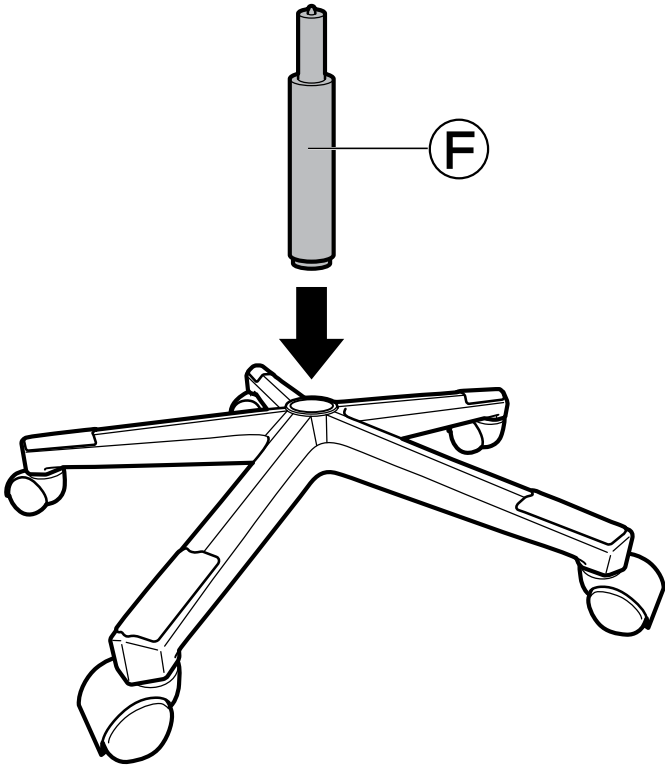

5

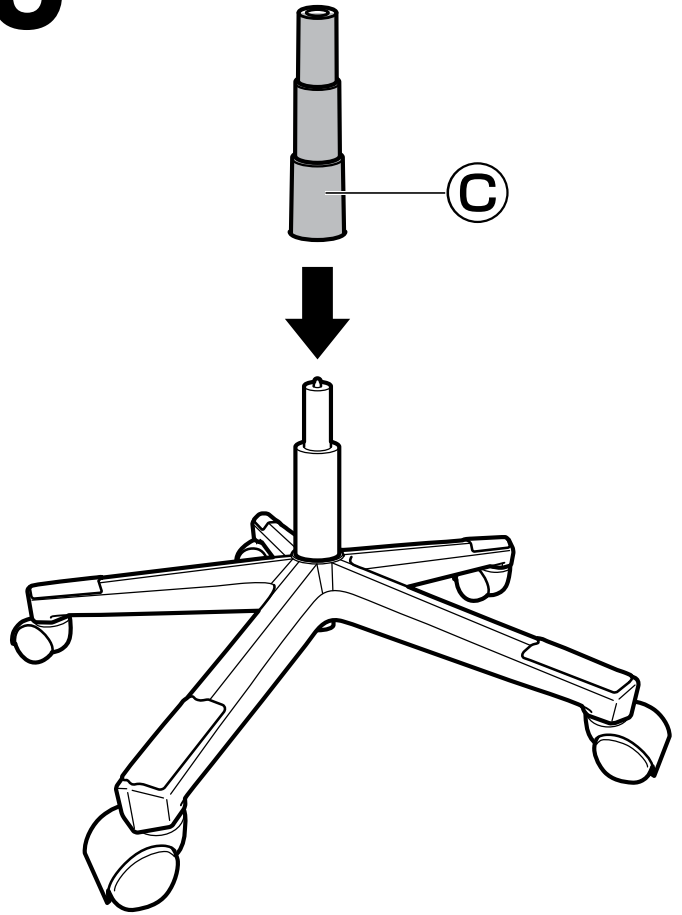

6



반드시 2명 이상이 지탱
하면서 조립해주세요.

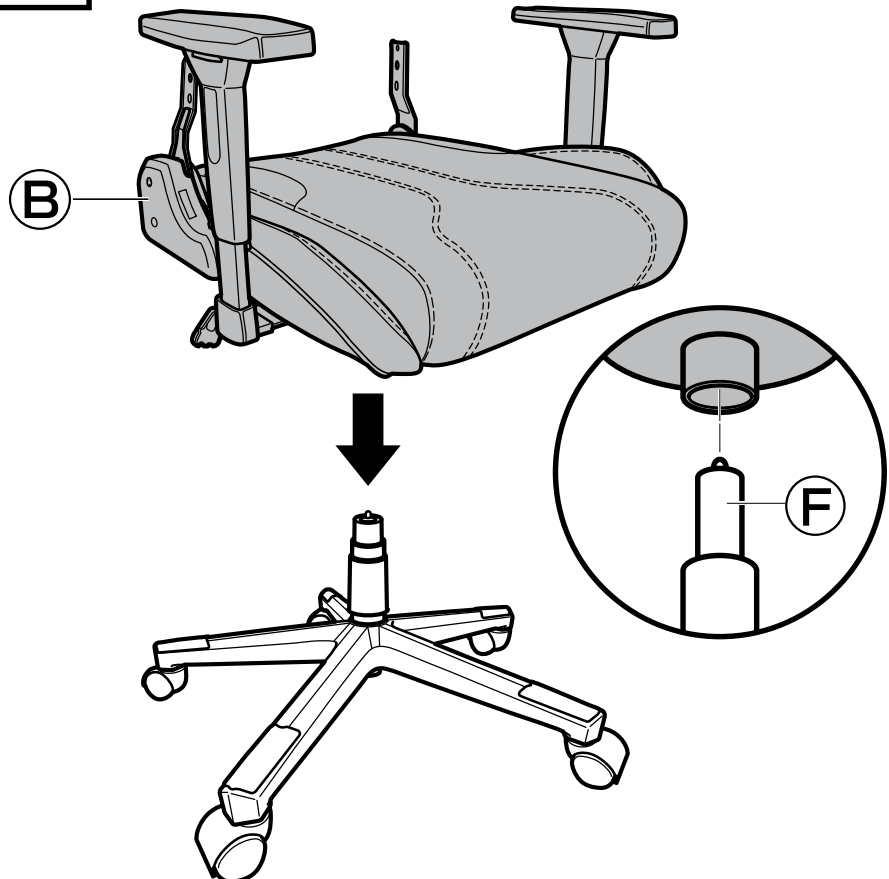

7

Ⓐ에 Ⓝ, Ⓛ을 설치합니다.
● 배면에서 버클을 고정시켜주세요.

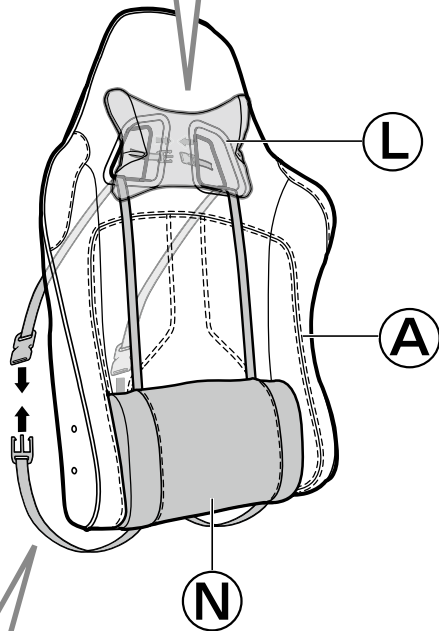

8

⚠ 반드시 2명 이상이 지탱
하면서 조립해주세요.

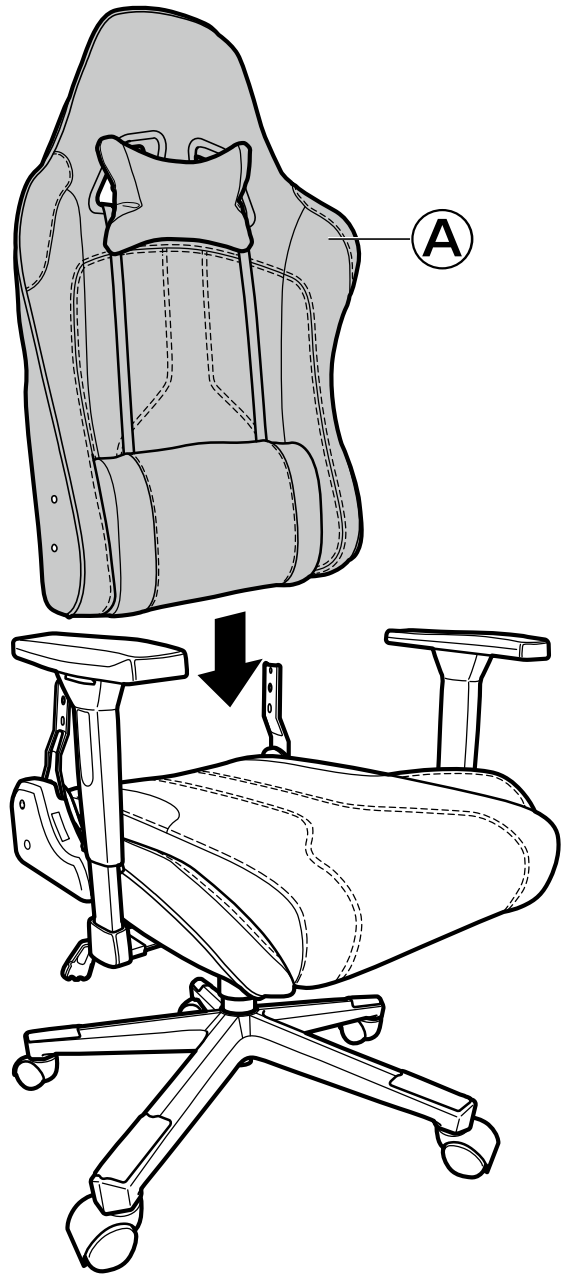

9

 반드시 2명 이상이 지탱하면서 조립해주세요.

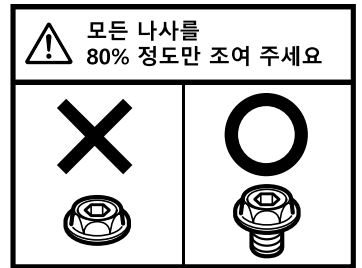
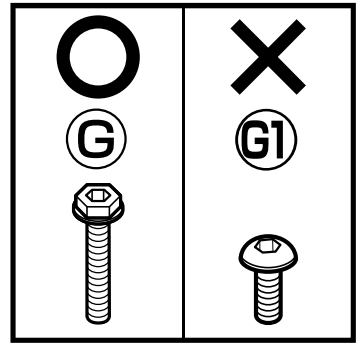
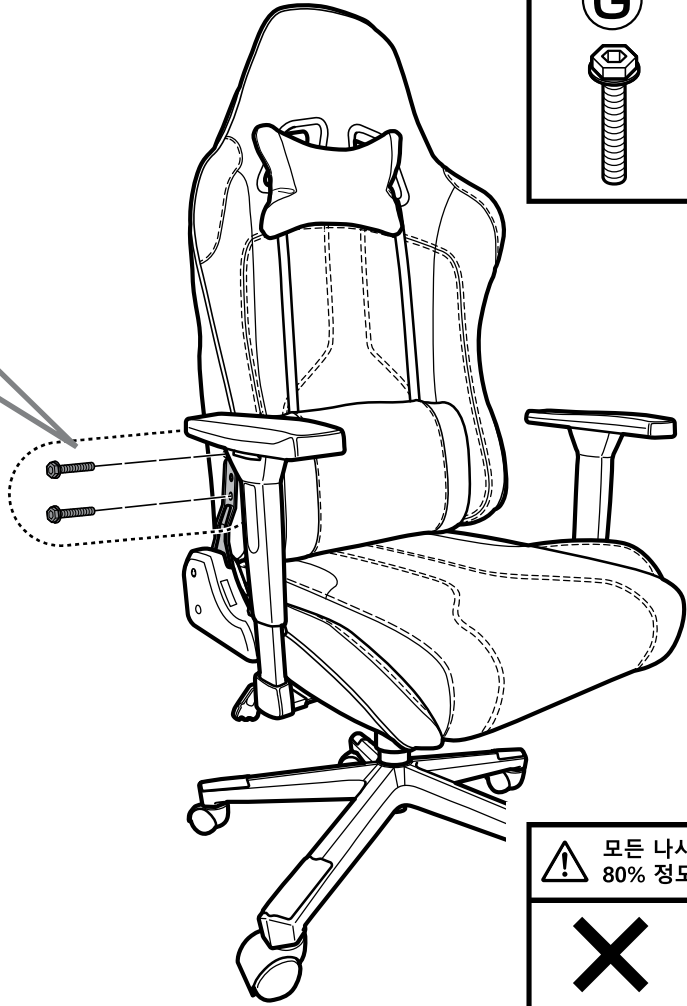
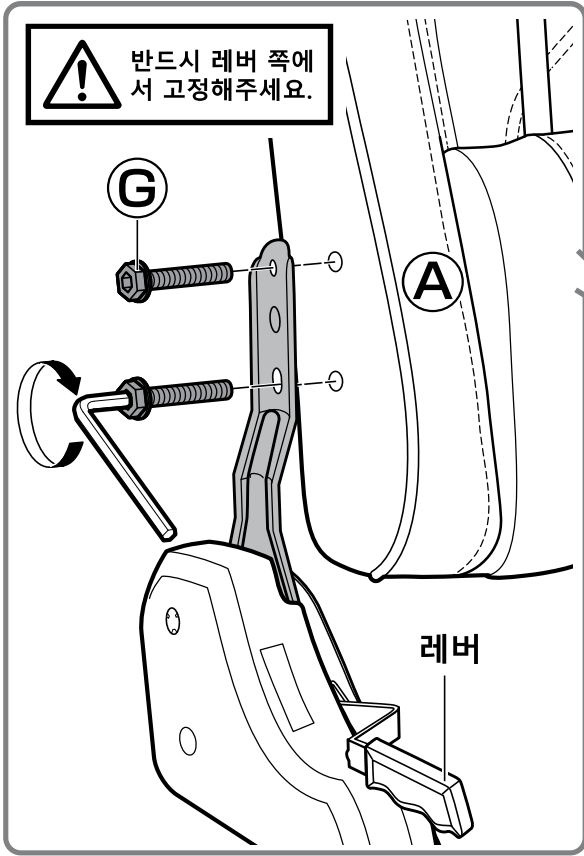

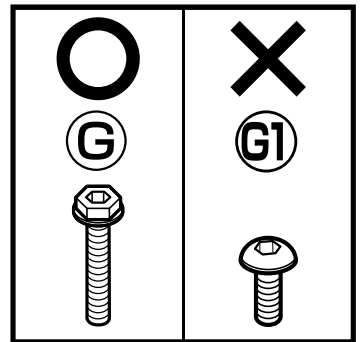
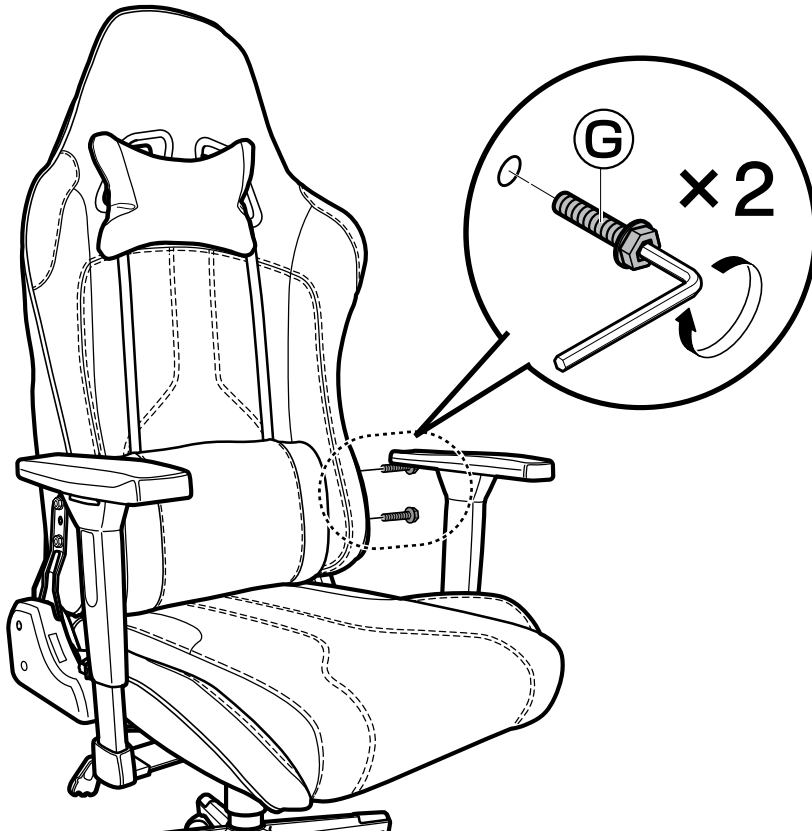

10



11

! 모든 나사를
80% 정도만 조여 주세요

	
---	---

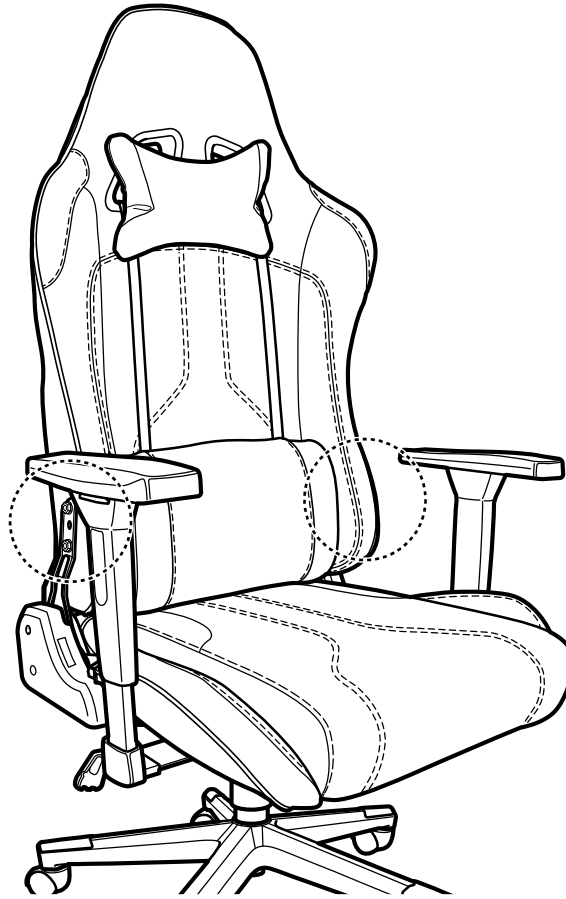

12

! 모든 나사를
완전히 조여 주세요

	
---	---

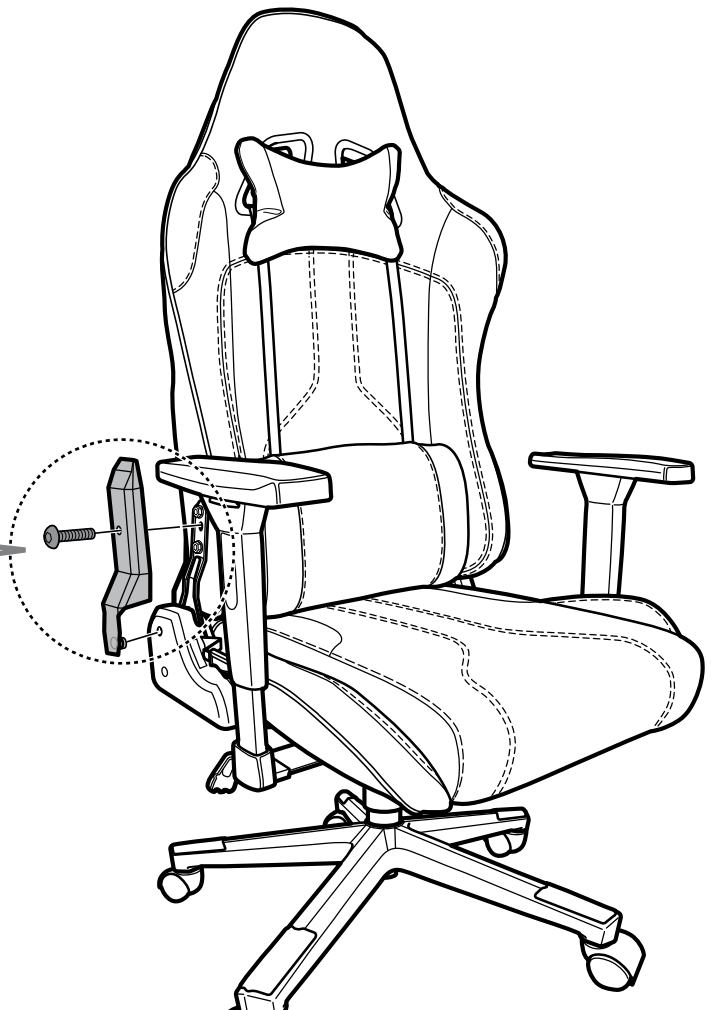
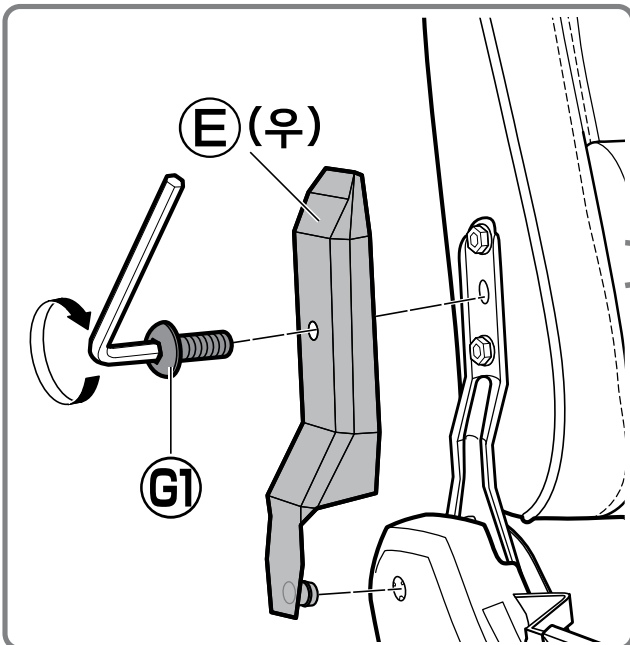

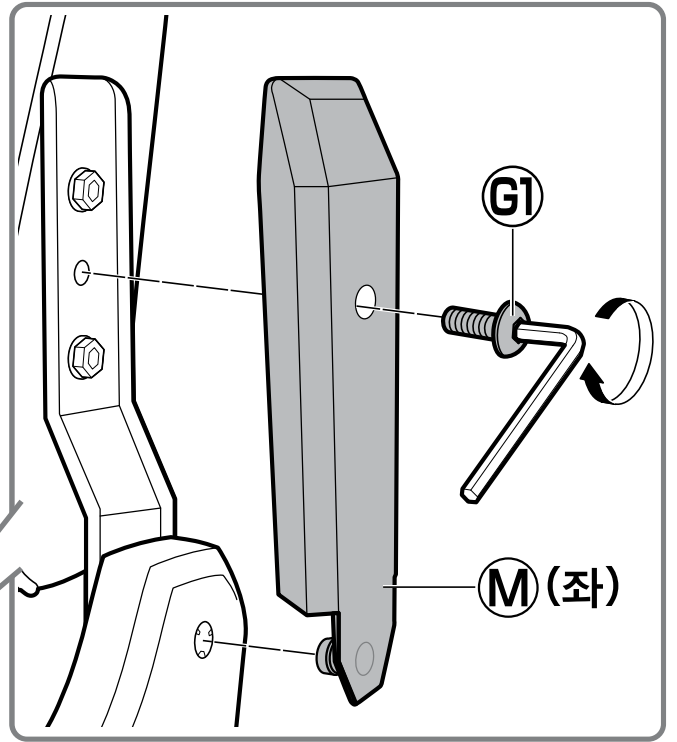
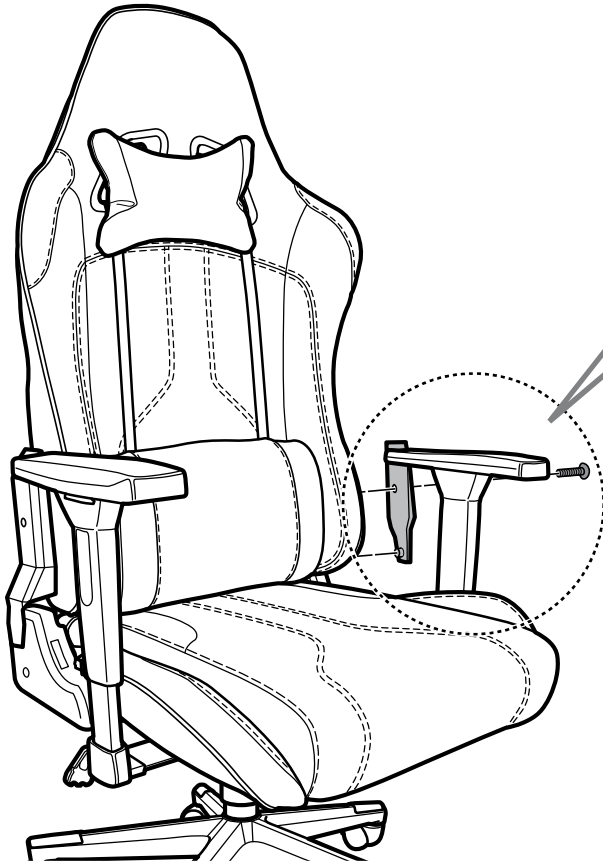
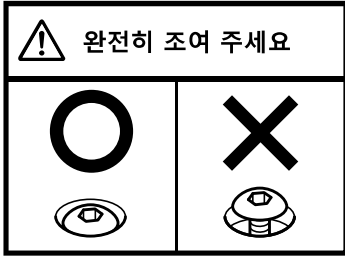

13

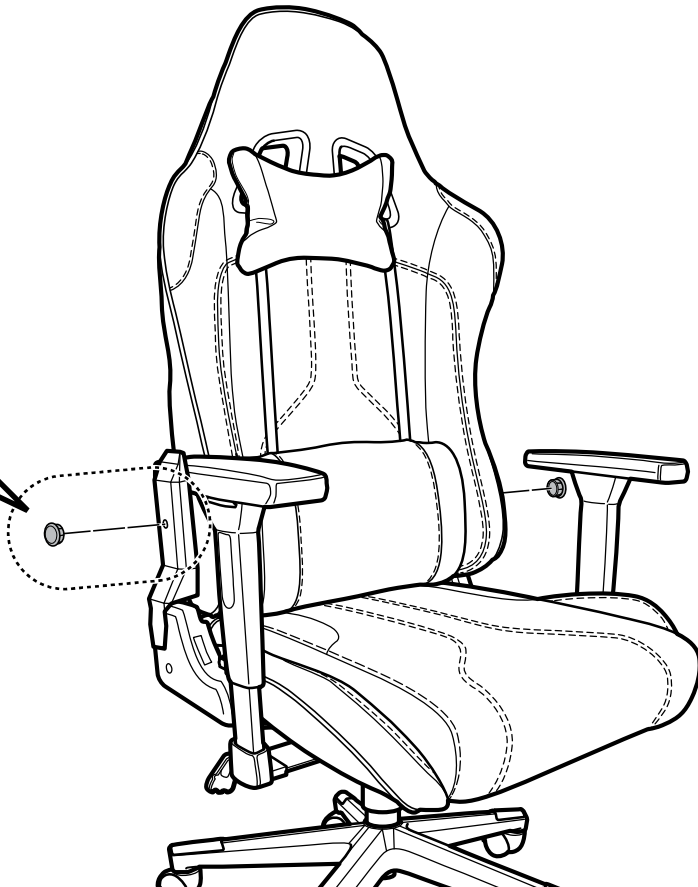
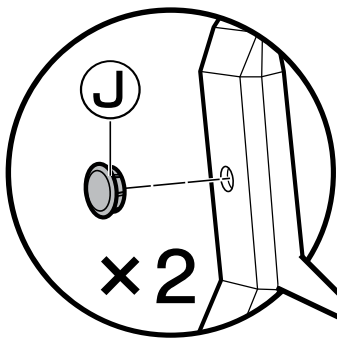

14

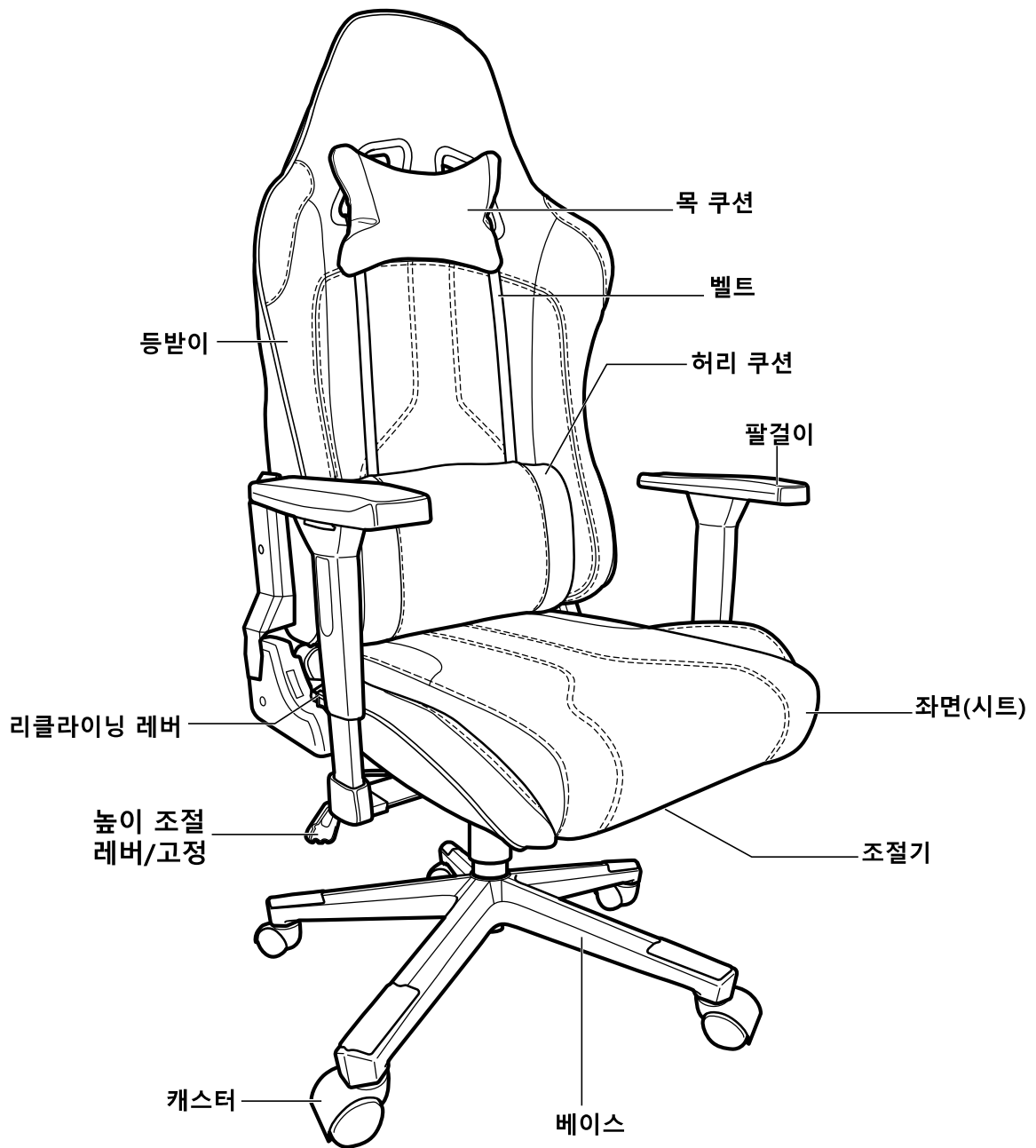



 각 부분의 헐거움이나 덜컹거림이 없는지 확인한 후 사용해 주세요.

높이 조절 방법

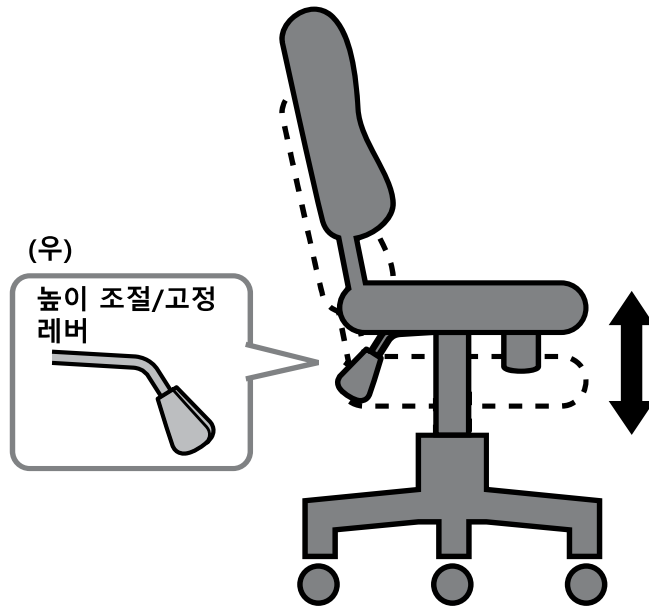

시트를 내리고 싶을 때

앉은 상태에서 레버를 화살표 방향으로 올립니다.

주의사항

- 체중이 가벼운 분은 시트가 내려가기 어려운 경우가 있습니다. 그런 경우, 다시 시트에 앉아 아래로 힘을 가해주세요.

시트를 올리고 싶을 때

허리를 든 상태에서 화살표 방향으로 올립니다.

등받이 각도 조절 방법

● 등받이를 뒤로 젖혀줍니다.

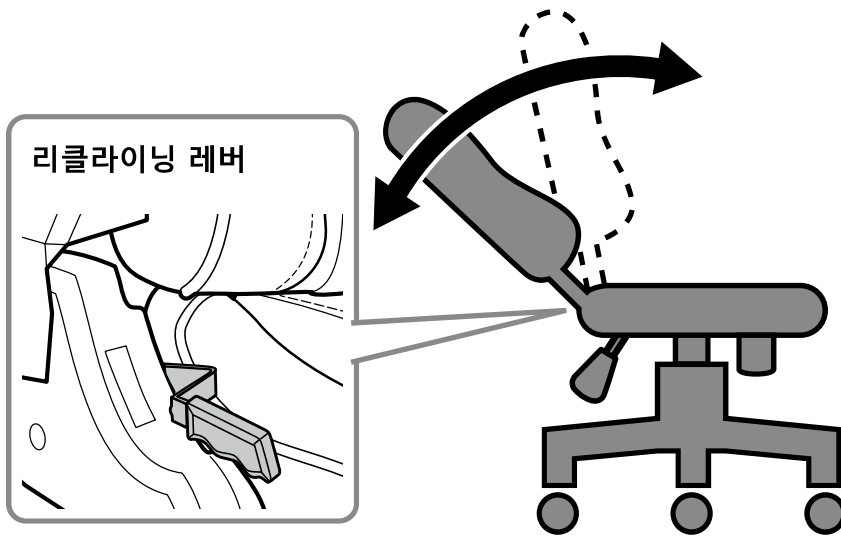

등받이를 취향에 맞는 각도로 고정합니다.

1 레버를 올립니다.

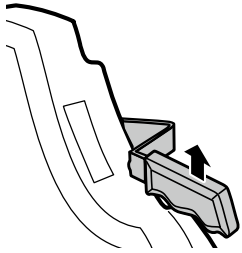

2 원하는 각도를 찾습니다.



3 레버를 놓습니다.

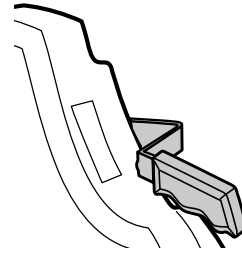

4 고정



등받이를 원래대로 되돌립니다.

1 레버를 올립니다.

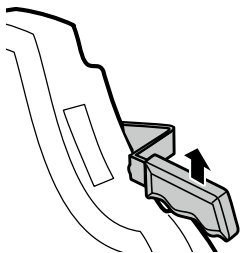

2 등받이에 체중을 실어 되돌립니다.

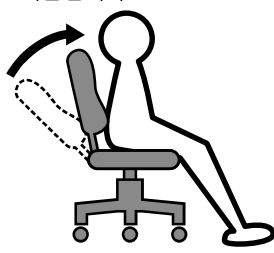

3 레버를 놓습니다.

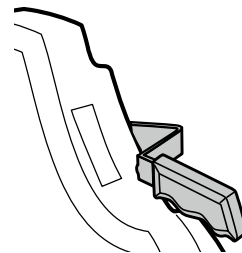

4 고정



등받이 · 좌면 흔들(록킹) 기능

등받이와 좌면(시트)이 일체화 된 상태에서 뒤로 젖혀집니다.

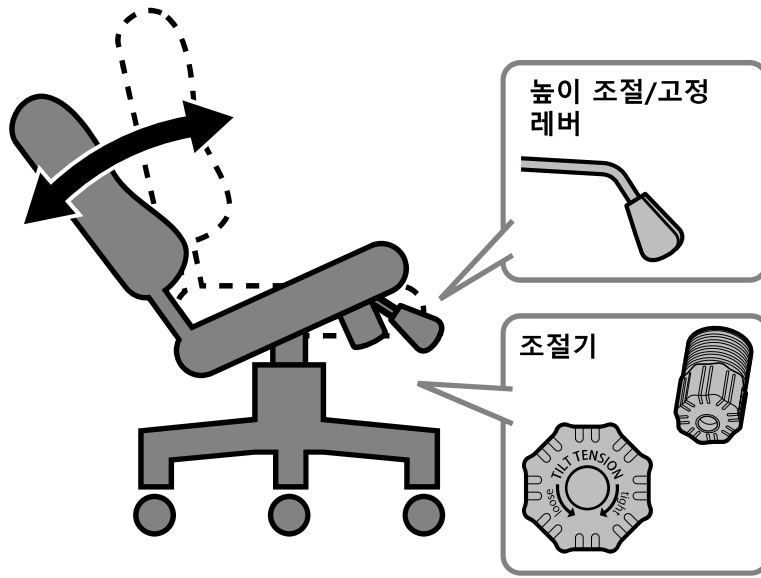

등받이의 고정을 해제합니다.
 ● 등받이에 체중을 실으면 흔들기능을 이용하실 수 있습니다.
 레버를 당긴 상태에서 사용합니다.

등받이를 고정합니다.

1 등받이를 되돌립니다	2 레버를 누릅니다	3 고정

조절기

loose 흔들 기능을 가볍게
tight 흔들 기능을 무겁게

팔걸이 조절 방법

해제

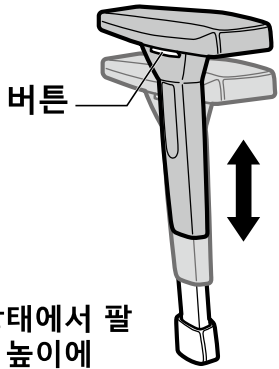

- 버튼을 누른 상태에서 팔걸이를 원하는 높이에 맞춰 조절하세요.

고정

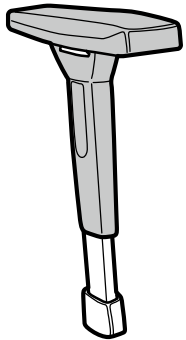

- 원하는 높이에 버튼을 놓아줍니다.



쿠션 조절 방법

- 쿠션을 잡고 움직이면 높이 조절이 가능합니다.

- 쿠션을 분리하여 사용하는 것도 가능합니다.

배면의 버클(목 쿠션 1곳, 허리 쿠션 2곳)을 해제하여 분리시켜 주세요.

