

Study Group

Jennifer L Parroccini Designs



Schematic

Finished

A - Full bust circumference: 31.25 (35, 39.25, 43) [47.25, 51, 55.25] (59, 63.25, 67) in / 78 (87.5, 98, 107.5) [118, 127.5, 138] (147.5, 158, 167.5) cm

B - Hip circumference: 35.75 (37.75, 42.25, 45.75) [50.25, 53.75, 58.25] (64, 68.25, 72.75) in / 89 (94.5, 105.5, 114.5) [125.5, 134.5, 145.5] (160, 171, 182) cm

C - Upper arm circumference: 11 (12, 13, 15) [15.75, 17, 18.5] (20, 21.5, 23) in / 27.5 (30, 32.5, 37.5) [39, 42.5, 46.5] (50, 53.5, 57.5) cm

D - Yoke depth: 7.25 (7.5, 7.75, 8.25) [8.75, 9, 9.25] (9.5, 10, 10.5) in / 18.5 (19, 19.5, 20.5) [22, 22.5, 23] (23.5, 25, 26.5) cm

E - Inner neck to bust apex: 9.5 (10, 10.5, 11.25) [11.75, 12.5, 13.25] (14, 14.75, 15.25) in / 24 (25, 26, 28) [29.5, 31, 33] (35, 37, 38.5) cm



Blocking

Body

A - Back neck width: 5.5 (5.75, 6.25, 6.5) [7, 7, 7.25] (7.75, 8, 8.25) in / 13.5 (14.5, 15.5, 16.5) [17.5, 17.5, 18] (19, 20, 21) cm

B - Full bust width: 16 (17.75, 20, 21.75) [24, 25.75, 28] (29.75, 32, 33.75) in / 40 (44.5, 50, 54.5) [60, 64.5, 70] (74.5, 80, 84.5) cm

C - Hip width: 18.25 (19.25, 21.5, 23.25) [25.5, 27.25, 29.5] (32.25, 34.5, 36.75) in / 45.5 (48, 53.5, 58) [63.5, 68, 73.5] (81, 86.5, 92) cm

D - Back neck depth: 1 in / 2.5 cm

E - Front neck depth: 5 (5, 5, 5) [5, 5, 5] (4.75, 4.75, 4.75) in / 12.5 (12.5, 12.5, 12.5) [12.5, 12.5, 12.5] (12, 12, 12) cm

F - Raglan depth: 6.5 (6.75, 6.75, 7) [7.5, 7.75, 8] (8, 8.5, 9) in / 16 (16.5, 16.5, 17.5) [19, 19.5, 20] (20, 21, 22.5) cm

G - Underarm to hem: 14 (14, 14, 13.5) [13, 12.75, 12.75] (12.75, 12.25, 12) in / 35 (35, 35, 33.5) [32.5, 32, 32] (32, 31, 29.5) cm

H - Hem depth: 2.5 in / 6.5 cm

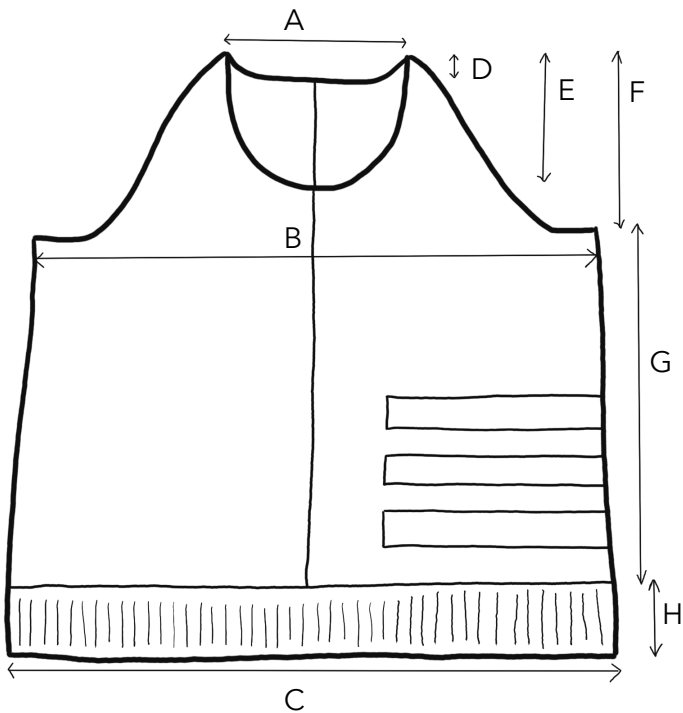

Sleeve

I - Shoulder width: 1.75 (1.75, 2.25, 2.25) [2.5, 2.5, 2.5] (3, 3, 3.25) in / 4.5 (4.5, 5.5, 5.5) [6.5, 6.5, 6.5] (7.5, 7.5, 8) cm

J - Upper arm width: 11.25 (12.25, 13.5, 15.25) [16, 17.5, 19] (20.25, 21.75, 23.25) in / 28 (31, 33.5, 38) [40, 43.5, 47.5] (51, 54.5, 58) cm

K - Wrist width: 8 (8, 8.25, 8.75) [8.75, 9, 9.5] (9.5, 9.75, 10.25) in / 20 (20, 21, 22) [22, 22.5, 23.5] (23.5, 24.5, 25.5) cm

F - Raglan depth: 6.5 (6.75, 6.75, 7) [7.5, 7.75, 8] (8, 8.5, 9) in / 16 (16.5, 16.5, 17.5) [19, 19.5, 20] (20, 21, 22.5) cm

L - Underarm to cuff: 17.75 (17.25, 17.75, 17.25) [17, 16.75, 16.5] (16.75, 16.5, 16) in / 44.5 (43.5, 44.5, 43.5) [42.5, 41.5, 41] (41.5, 41, 40) cm

M - Cuff depth: 2 in / 5 cm

