

Non e permesso consegnare a terzi o riprodurre questo documento, ne utilizzare il contenuto o renderlo comunque noto a terzi senza autorizzazione esplicita. Ogni infrazione costituira un evidente abuso e comportera il risarcimento dei danni subiti. E' fatto riserva di tutti i diritti derivanti da brevetti o modelli.

Copying of this document and giving it to others and the use or communication of the contents thereof, are forbidden without express authority. Controvention of this restriction will constitute an evident abuse and result in a liability to the payment of damages. All rights are reserved in the event of the grant of patent or registration of a utility model or design. This document is the subject of copyright.

Toute communication ou reproduction de ce document, toute exploitation ou communication de son contenu sont interdites, sauf autorisation expresse. Tout manquement a cette regle constitue un abus evident et expose son auteur au versement de dommages et interets. Tous droits de proprieete industrielle reserves, notamment en matiere de brevets et de modesles.

Weitergabe sowie Vervielfaeligung dieser Unterlage, Verwertung und Mitteilung ihres Inhalts nicht gestattet, soweit nicht ausdruecklich zugestanden. Zuwiderhandlungen stellen einen offensichtlichlichen Missbrauch dar und verpflichten zu Schadenersatz. Alle Rechte fuer den Fall der Patenterteilung oder Gebrauchsmuster-Eintragung vorbehalten.

1	2	3	4	5	6	7	8			
A	B	C	D	E	F	G	H	I	J	K
for Tube 12x1,5 new Line <CI>	M22x1,5	9	Hex.28	Ø22,3	27,8	34Nm (40Nm)	(25) Push in length <CI>	2	Ø28,3	with O-ring

G : recommended torque without lubrication (max. torque) respect max torque of counter part

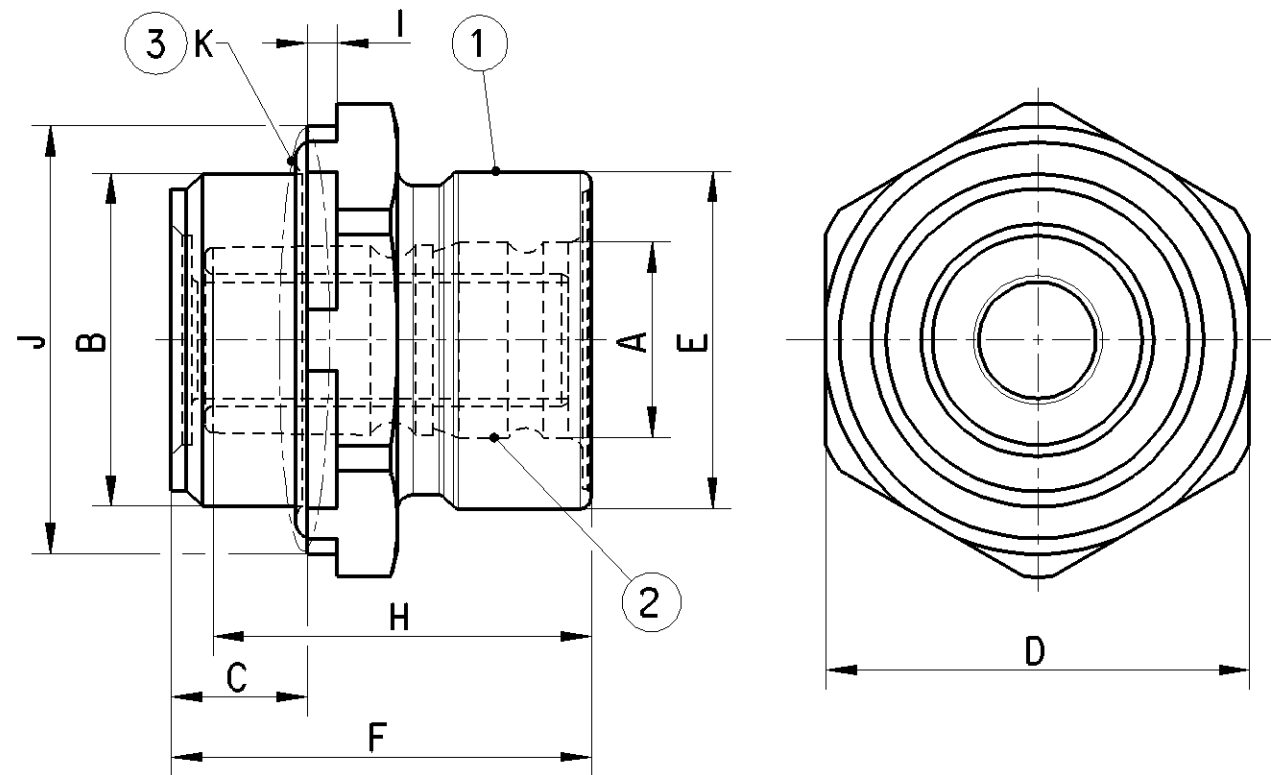

Cleanliness requirement:

Class: K00 according JED-593

Area: for the whole part (Special agreements possible; to be agreed with Product Engineering)

Material:

- ① CuZn
- ② PA (inner components)
- ③ EPDM

General Specification : JED-762 ; JED-622 ; JED-220

Engineering related agreements with Supplier have to be mentioned in the "Release of Supplier"

For use in application in compressed air systems in commercial vehicles :

- with Polyamid or Hytrel tubes acc. ISO7628; DIN74324, DIN73378
- with compressed air acc. JED-848
- at working conditions (consider tube spec.) :
 - -40 °C ... 100 °C
 - max. 12,5 bar

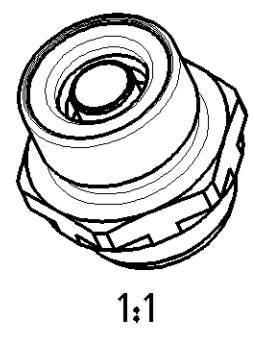

General Specification: JED-334-1, Size ISO 14405 LP				Copyright WABCO®		WABCO			
Further Technical Data:				Date	Signature				
Doc. Code:		Sheet:		To		Screw-in Fitting			
General Tolerances				2019-11-29		Balago			
Range of Nominal Dimensions (± mm)				Checked		2019-12-11			
				Expert		Szczulkowski			
				Szczulkowski					
Class	1)	≤ 50	> 50 ≤ 180	> 180 ≤ 400	> 400	Mass	Scale	Material No.	Date of first issue: 2007-02-06
Fine	X	0.5	1.0	1.5	2.0	0.050	2:1	893 800 008 2	Doc.Code
Medium		1.0	2.0	3.0	4.0	KG	1:1		005
Coarse		2.0	3.5	5.0	6.5	Size	CAD System	EN	Sheet
Tapped Holes acc. -				A 3		CREO		1/1	
1) Tolerance Class Applied Crossmarked				502571		2 x C		5790	

