

**Operatore elettromeccanico per cancelli scorrevoli**

*Istruzioni d'uso ed avvertenze*

**Electromechanical operators for sliding gates**

*Operating instructions and warnings*

**Opérateurs électromécaniques pour portails coulissants**

*Notice d'emploi et avertissements*

**Operador electromecánico para cancelas correderas**

*Instrucciones de uso y advertencias*

**Operador electromecânico para portões de correr**

*Instruções para utilização e advertências*

**DEA<sup>®</sup>**



SCORREVOLI

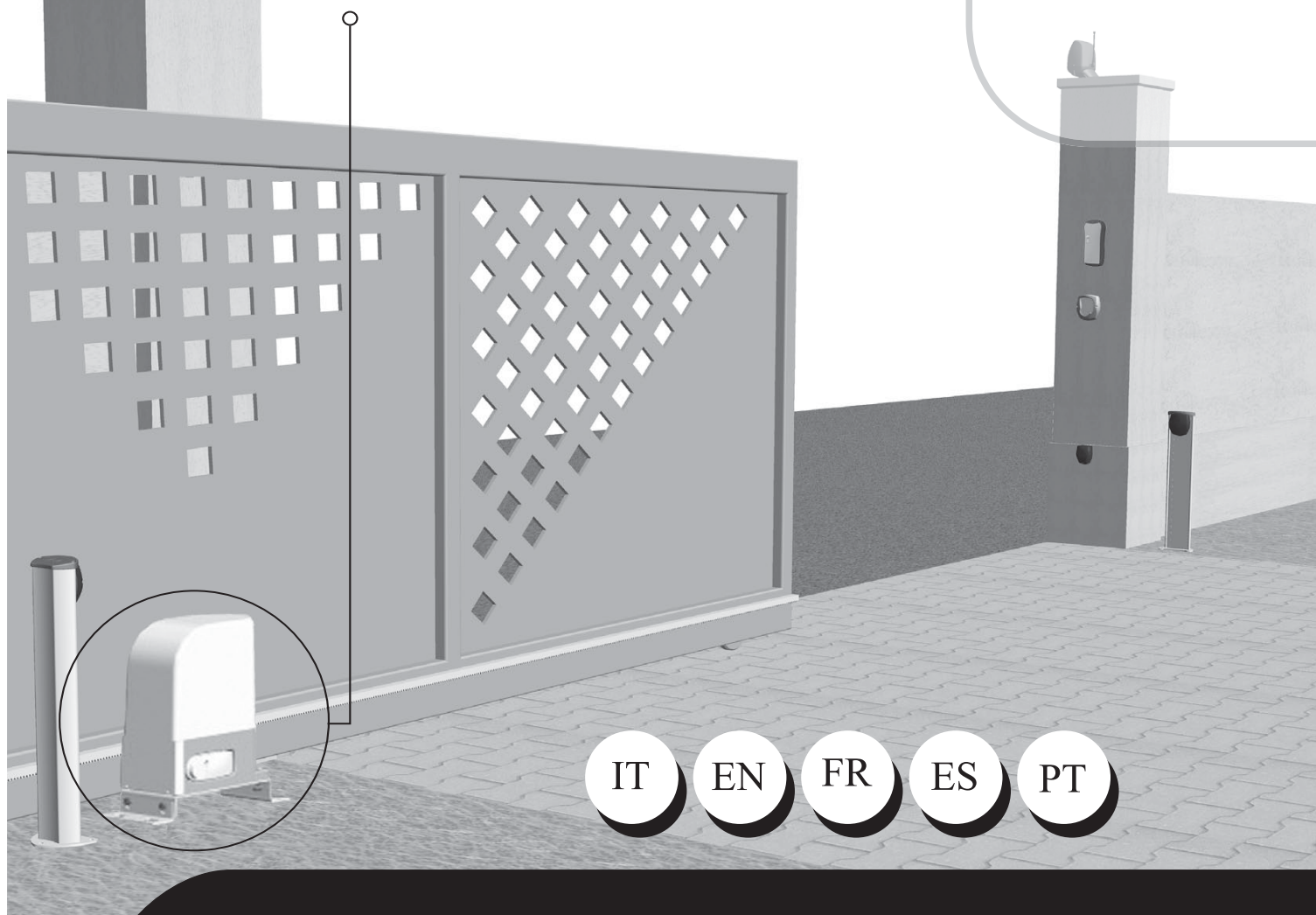

IT

EN

FR

ES

PT

## IT UTILIZZO DEL LIBRETTO

Per facilitare la comunicazione e la rintracciabilità di particolari importanti informazioni all'interno del testo DEA System adotta la simbologia riportata.

## EN USE OF THIS BOOKLET

In order to facilitate communication and the traceability of particularly important parts of the text, DEA System adopts the symbols provided.

## FR UTILISATION DE CE LIVRET







Pour faciliter la communication et le repérage de renseignements spéciaux et importants à l'intérieur du texte, DEA System a adopté la symbolologie indiquée.

## ES UTILIZACIÓN DEL MANUAL

Para facilitar la comunicación y la trazabilidad de informaciones de particular importancia, DEA System adopta, en el interior del texto, la simbología reproducida.

## PT UTILIZAÇÃO DO FOLHETO

Para facilitar a comunicação e localizar pormenores importantes de informações no interior do texto, a DEA System adoptou os símbolos apresentados.

	Avvertimento Warning Avertissement Advertencia Advertência
	Pericolo Danger Danger Peligro Perigo
	Consultazione Consultation Consultation Consultación Consulta
	Osservazione Observation Observation Observación Observação
	Ispezione Inspection Inspection Inspección Inspeção
	Certificazione Certification Certification Certificación Certificado

La Dichiarazione di Incorporazione può essere consultata sul sito  
The Declaration of Incorporation may be consulted by entering  
La Déclaration d'Incorporation peut être vérifié à l'adresse  
La Declaracion de Incorporación puede ser consultada en la dirección de internet  
A Declaração de Incorporação pode ser consultada em  
Deklarację Włączenia można skonsultować wchodząc na stronę

**<http://www.deasystem.com/area-download>**

Nome ed indirizzo della persona autorizzata a costituire la  
Documentazione Tecnica pertinente:

**DEA SYSTEM S.p.A.**  
**Via Della Tecnica, 6**  
**36013 PIOVENE ROCCHETTE (VI) - ITALY**

LIEVORE TIZIANO  
Amministratore



### INDEX

Declaration by manufacturer .....	1
OVERVIEW .....	7
<b>1 PRODUCT CONFORMITY</b> .....	<b>7</b>
<b>2 RESIDUAL RISK WARNINGS</b> .....	<b>7</b>
<b>3 MODELS AND CONTENTS OF THE PACKAGE</b> ...	<b>8</b>
<b>4 OPERATING INSTRUCTIONS</b> .....	<b>8</b>
4.1 Product description .....	8
4.2 Technical data.....	8
4.3 Labelling information.....	8
4.4 Appropriate conditions of use .....	8
4.5 Instructions for risk-free operation .....	9
4.5.1 Transport – 9	
4.5.2 Installation, assembly and disassembly – 9	
4.5.3 Starting – 9	
4.5.4 Use – 9	
4.5.5 Adjustment – 9	
4.5.6 Maintenance and repair – 9	
4.6 Training .....	10
4.7 Inappropriate use.....	10
<b>5 SPARE PARTS LIST</b> .....	<b>10</b>
<b>6 COMPLETE CLOSING ASSEMBLY</b> .....	<b>10</b>
6.1 Minimum level of protection provided by the safety edge.....	10
6.2 Crushing in the opening area .....	10
6.3 Impact in the opening/closing area ....	10
Example of typical installation .....	27

### ANNEXES

- Instructions for the final user
- Terms of warranty

### OVERVIEW

#### SCOPE OF THE INSTRUCTIONS

These instructions were prepared by the manufacturer and are an integral part of the product. The operations described are intended for adequately trained and qualified operators and must be carefully read and conserved for future reference.

Chapters "2 RESIDUAL RISK WARNINGS" and "4 OPERATING INSTRUCTIONS" contain all the information that **DEA** System provides in order for the product to constantly satisfy the Essential Safety Requirements prescribed by the Machinery Directive (European Directive 2006/42/CE). Read these chapters carefully because they contain important instructions for safe installation, use and maintenance and important warnings regarding the residual risks remaining even after all the safety devices and measures described have been applied. The product is designed for installation in complete closing systems subject to specific legislation. Chapter 6 "COMPLETE CLOSING ASSEMBLY" provides useful information for the respect of the Essential Safety Requisites for special types of closing.



#### **1 PRODUCT CONFORMITY**

**DEA** System guarantees the conformity of the product to European Directives 2006/42/CE regarding machinery safety, 2004/108/CE electromagnetic compatibility and 2006/95/CE low voltage electrical equipment. **DEA** System also encloses the

manufacturer's Declaration of Conformity with these instructions (see Directive 2006/42/CE Art. 4, paragraph 2).



### **2 RESIDUAL RISK WARNINGS**

Read these warnings carefully; the failure to respect the following warnings can create risk situations.

**WARNING** The use of the product under unusual conditions not foreseen by the manufacturer can create situations of danger, and for this reason all the conditions prescribed in these instructions must be respected.

**WARNING** Under no circumstances must the product be used in explosive atmospheres or surroundings that may prove corrosive and damage parts of the product.

**WARNING** All installation, maintenance, cleaning or repair operations on any part of the system must be performed exclusively by qualified personnel with the power supply disconnected working in strict compliance with the electrical standards and regulations in force in the nation of installation

**WARNING** All other adjustment/setting operations beyond the adjustment of the limit switch cams and of the mechanical clutch are made by the manufacturer. Tampering with these settings may cause malfunction and/or situations of risk to people, animals and property. Refrain from performing any operations not authorised by **DEA** System.

**WARNING** The use of spare parts not indicated by **DEA** System and/or incorrect re-assembly can create risk to people, animals and property and also damage the product. For this reason, always use only the parts indicated by **DEA** System and scrupulously follow all assembly instructions.

**WARNING** Awareness of the operation of the key-release mechanism (see F9 Page 32) is essential for all users of the automatism because the failure to use the device quickly during emergencies can jeopardise people, animals and property. Enclosure I to these instructions, which the installer is required to deliver to the final user, illustrates operation and can be detached.

**WARNING** **DEA** System reminds all users that the selection, positioning and installation of all materials and devices which make up the complete automation system, must comply with the European Directives 2006/42/CE (Machinery Directive), 2004/108/CE (electromagnetic compatibility), 2006/95/CE (low voltage electrical equipment). In order to ensure a suitable level of safety, besides complying with local regulations, it is advisable to comply also with the above mentioned Directives in all extra European countries.

**WARNING** To ensure an appropriate level of electrical safety always keep the 230V power supply cables apart (minimum 4mm in the open or 1 mm through insulation) from low voltage cables (motors power supply, controls, aerial and auxiliary circuits power supply), and fasten the latter with appropriate clamps near the terminal boards.

**WARNING** Any external safety device installed in order to conform to the limits set for impact forces must comply with EN 12978.



**WARNING** Wrong assessment of impact forces may cause serious damage to people, animal and things. DEA System reminds all personnel that the installer must ascertain that these impact forces, measured according to EN 12445 prescriptions, are actually below the limits indicated by EN14453 regulation.



**WARNING** In line with EU Directive 2002/96/EC for waste electrical and electronic equipment (WEEE), this electrical product must not be disposed of as unsorted municipal waste. Please dispose of this product by returning it to your local municipal collection point for recycling.



### 3 MODELS AND CONTENTS OF THE PACKAGE

The name LIVI identifies a series of electromechanical operators with different features as to motor and control board power supply voltage, range of built-in or external control board and mechanical adjustment of force, electronic clutch and built-in limit switch. DEA System articles in the series are listed in the "AVAILABLE MODELS" table. LIVI is completed by a set of accessories listed in the "PRODUCT ACCESSORIES" table. Inspect the "Contents of the Package" on Page 30 and compare it with your product for useful consultation during assembly.



## 4 OPERATING INSTRUCTIONS

In compliance with Directive 2006/42/CE Enclosure I, Point 1.7.4.

### 4.1 Product description

LIVI is an electro-mechanical operator designed for the automation of sliding gates. LIVI is basically made up of a mechanical gear motor (vedi F1 pag. 30) rotating the draft gear that, in association to a properly installed rack, converts the circular movement of the gear motor into straight-line movement, thus allowing the gate to move in its own slide.





### 4.2 Technical data

See the "TECHNICAL DATA" table.

### 4.3 Labelling information

Part of the summarised data for the CE label are listed in the label applied to the product (see Position F5, Page 30); the data regarding the seller are found in the enclosed Warranty, while "Indispensable Operating Safety Elements" are found under Point "4.2 Technical data".

"PRODUCT ACCESSORIES" table

Article Code	Description
111 619000	 Nylon rack
112 126001	 Zinc plated rack 22x22
113 126000	 Zinc plated rack 30x12
460 619010	 Foundation base to be cemented

### 4.4 Appropriate conditions of use

The LIVI is designed for installation in sliding gates as an actuator for the operational automatism as shown in F3 on Page 31. Brackets for both "horizontal" (standard) and "vertical" (see "PRODUCT ACCESSORIES" table) installation have been arranged for. The LIVI has been designed and tested for operation under "normal" civil gate opening conditions; temperature limits, degrees of protection against dust and water, and other data are provided in Point 4.2 "Technical Data". Satisfactory operation requires the correct positioning of the LIVI operator with respect to the gate; DEA System recommended measurements are shown in F3 page 31. The automatism required must be selected according to the gate to be moved; the attrition on the attachments, the weight, the length/height of the gate wing, and the degree of closing of the surfaces are the elements to be considered.

**WARNING** The use of the product under unusual conditions not foreseen by the manufacturer can create situations of danger, and for this reason all the conditions prescribed in these instructions must be respected.

**WARNING** Under no circumstances must the product be used in explosive atmospheres or surroundings that may prove corrosive and damage parts of the product.

	403E - 6NET	803E - 9NET	5/24NET/F	8/24NET/F
Motor power supply voltage (V)	230 V ~ ±10% (50/60 Hz)		24 V ===	
Absorbed power (W)	320	450	80	110
Max Thrust (N)	340	490	210	260
Work cycle (leaf L=5m)	18 cycles/hour	11 cycles/hour	22 cycles/hour	18 cycles/hour
Max n° of operations in 24 hour (leaf L=5m)	60	40	60	40
Built-in capacitor (µF)	8	12,5	-	
Operating temperature range (°C)	-20 ÷ 40 °C			
Motor thermal protection (°C)	140 °C	160 °C	-	
Opening speed (m/min)	10			
Weight of product with package (Kg)	11	12,5	12	
Protection degree	IPX4			



## 4.5 Instructions for risk-free operation

### 4.5.1 Transport

The LIVI gate operator is always delivered packed in boxes that guarantee the product adequate protection. Carefully read any warnings or instructions for storage and handling provided on the box.

### 4.5.2 Installation, assembly and disassembly

The following operations are essential to the correct laying of the product:

- The careful definition of the entire automatic opening layout (see also paragraph "6 Complete Closing Assembly"); in particular, after carefully assessing the characteristics of the place you have selected, define model and correct positioning of the foundation base (see F3, pages 31);
- screw in the foundation base (see F8 page 32) or put it in concrete with item nr. 460;
- Check carefully the correct positioning of the foundation base;
- Screw LIVI and the foundation base together using appropriate screws (see F7 page 32);

**WARNING** All installation, maintenance, cleaning or repair operations on any part of the system must be performed exclusively by qualified personnel with the power supply disconnected working in strict compliance with the electrical standards and regulations in force in the nation of installation.

### 4.5.3 Starting

The installation of the product requires masonry and/or welding and electrical connection operations using adequate equipment for the job in complete respect of the accident-prevention standards and regulations in force in the nation of installation.

The product must be electrically connected to a gate operator control board which is built-in in some LIVI models; see the instructions provided for such device for further information.

### 4.5.4 Use

The product is destined for incorporation in the assembly of devices that comprise the gate's automatism. **DEA** System assumes that it will always be used in compliance with the standards and regulations in force.

All LIVI models have an unlocking system; the working of this system is the following: after unlocking the lock on the handle (protected by a plastic cover) turn the lever in the direction shown in F9, page 32; the operator is now unlocked and, if no obstructions hinder its movement, the gate can now move freely. The opposite procedure, that is the rotation of the lever up to the limit switch and the locking of the lock (remember to protect

the lock with the appropriate cover) returns LIVI to its normal working conditions.

### 4.5.5 Adjustment

Each LIVI model is equipped with a limit switch whose operation must be adjusted on site. **DEA** System supplies two limit switch cams (see F4 page 30) which must be installed on the gate rack and subsequently adjusted so as to guarantee the gate functionality and safety distance both during opening and closing. Some LIVI models are equipped with mechanical clutch to limit the pressure of the gate against an obstacle obstructing its travel while opening or closing. Follow these instructions to adjust it (see F6 page 31):

- disconnect power supply to the operator;
- hold firmly the motor shaft with a wrench while rotating the grub screw with an Allen wrench (turn clockwise to increase force, and turn counterclockwise to reduce force);

**WARNING** All the other adjustment/setting operations beyond the adjustment of the oil flow are made by the manufacturer. Tampering with these settings may cause malfunction and/or situations of risk to people, animals and property. Refrain from performing any operations not authorised by **DEA** System.

### 4.5.6 Maintenance and repair

Good preventive maintenance and regular inspection ensure long working life (see also "Warranty"). Consult the "TROUBLE-SHOOTING" table (see page 9) whenever anomalies are observed in order to find the solution to the problem and contact **DEA** System directly whenever the solution required is not provided.

The inspection/maintenance operations to be routinely scheduled in the "complete automatism maintenance register" are:

INTERVENTION TYPE	PERIODICITY
cleaning of external surfaces	6 months
checking of screw tightening	6 months
checking of release mechanism operation	6 months

**WARNING** All installation, maintenance, cleaning or repair operations on any part of the system must be performed exclusively by qualified personnel with the power supply disconnected working in strict compliance with the electrical standards and regulations in force in the nation of installation.

**WARNING** The use of spare parts not indicated by **DEA** System and/or incorrect re-assembly can create risk to people, animals and property and also damage the product. For this reason, always use only the parts indicated by **DEA** System and scrupulously follow all assembly instructions.

"TROUBLE-SHOOTING" table

MALFUNCTION	CAUSES / SOLUTIONS
When the opening or closing command is activated the gate leaf fails to move and the operator's electric motor fails to start.	The operator is not receiving correct power supply. Check all connections, fuses, and the power supply cable conditions and replace or repair if necessary. If the gate does not close check the correct functioning of photocells.
When the opening command is activated, the motor starts but the gate leaves fail to move	Check that the unlocking system is closed (see F9, page 32)
	Check the electronic force adjustment device and the mechanical clutch
The gate moves by fits and starts, it is noisy, it stops at half run or it does not start	Make sure that the motor does not push in the opposite direction, the limit switch electrical connections might be reversed
	Make sure that nothing hinders the gate wheels movement and the slide in which they roll;
	There always must be backlash between rack and pinion; make sure the rack is accurately positioned.
	The power of the gearmotor may be insufficient for the characteristics of the gate's wing; check the choice of model whenever required
	If the operator attachment to the gate bends or is badly fastened, repair and/or buttress it.



### 4.6 Training

After installation and setting, the correct operation of the complete automatism must be carefully illustrated to the final user.

The LIVI gate operator requires careful instruction on the release mechanism (see "Enclosures") in particular and the respective maintenance schedule (see Point 4.5.6.).

**WARNING** Awareness of the operation of the LIVI key-release mechanism (see F9 Page 32) is essential for all users of the automatism because the failure to use the device quickly during emergencies can jeopardise people, animals and property. Enclosure I to these instructions, which the installer is required to deliver to the final user, illustrates operation and can be detached.

### 4.7 Inappropriate use

Chapter "4.4 Appropriate conditions of use" describes the conditions for which the product has been designed and tested. The product must never be used for other purposes.

**WARNING** The use of the product under unusual conditions not foreseen by the manufacturer can create situations of danger, and for this reason all the conditions prescribed in these instructions must be respected.

**WARNING** Under no circumstances must the product be used in explosive atmospheres or surroundings that may prove corrosive and damage parts of the product.



## 5 SPARE PARTS LIST

The list of spare parts that can be ordered (Pages 28, 29 and 33) is a detailed list that accompanies the exploded view of the product and must be used to order spare parts.

The following data must always be provided when ordering spare parts:

- the code of the product (seen on the product label; see F5, Page 31),
- the part's position number in the exploded view,
- if available, the product's purchase date may be useful in some cases.



## 6 COMPLETE CLOSING ASSEMBLY

This chapter illustrates the typical installation of a complete automatism for the purpose of informing and assisting the installer in the selection of the various parts to be used in compliance with Machinery Directive (2006/42/CE) and European Safety Standards (EN 14453 - EN 12445) for gate installation.

The data provided in this chapter are neither complete nor exhaustive, and **DEA** System declines all liability for any errors, omissions or inaccuracies that may occur.

### 6.2 Crushing in the opening area

The risk of crushing can also arise in the area between the gate being opened and the wall or other construction behind it. F10 on Page 32 provides the measurements that must be respected whenever measures are not taken to limit the impact force or whenever presence detection systems are not used.

### 6.3 Impact in the opening/closing area

Install a pair of photocells on one or the other side of the gate or on both in order to avoid the risk of impact with the gate in the closing area. (recommended height: 500 mm) in order to detect the presence of the test parallelepiped (height: 700 mm) positioned as shown in F11 on Page 32.

Note. The presence detection test sample is a parallelepiped with 3 sides with light-coloured reflecting surfaces and 3 sides with dark-coloured, opaque surfaces.

Make sure there is no conflict when the photocells are installed on both sides. The system working on the gate side where the test sample is positioned must detect all test objects.

### 6.1 Minimum level of protection provided by the safety edge

The risk of getting crushed between the gate and the fence or wall and/or other fixed parts is among the most serious risks to be considered when automating a sliding gate is. An appropriate type of operating control board must be used according to the gate type and use against such risk, as provided for by the quoted regulations (see "OPERATING CONTROL" table).



“EXAMPLE OF TYPICAL INSTALLATION” picture

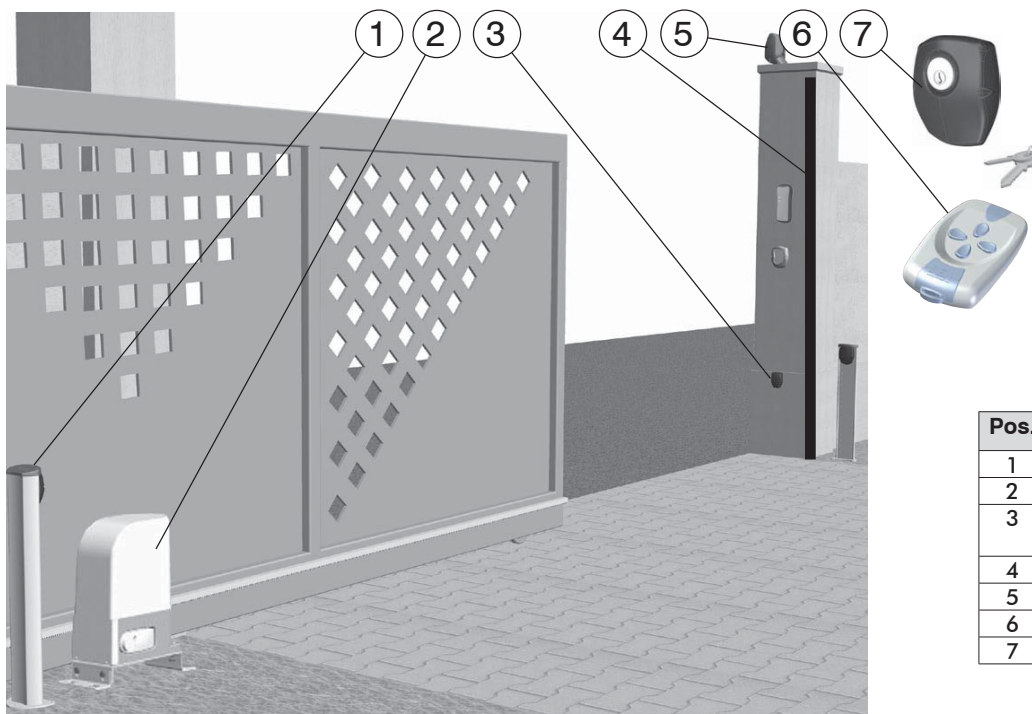

Pos.	Description
1	1Pilly 60 column
2	LIVI
3	104 Lux series photocells
4	Safety edge
5	Lumy flashing light
6	Remote-control
7	102 Lux key selector

“OPERATING CONTROL” table

Type of control	Type of use		
	Informed users (private areas)	Informed users (public areas)	Uninformed users
Person-present control	Pushbutton control	Pushbutton control with key	The person-present control is not possible
Pulse control with the gate in sight	Force limitation or presence detectors	Force limitation or presence detectors	Force limitation and photocells or presence detectors
Pulse control with the gate not in sight	Force limitation or presence detectors	Force limitation and photocells or presence detectors	Force limitation and photocells or presence detectors
Automatic control (i.e. control with timed closing)	Force limitation and photocells or presence detectors	Force limitation and photocells or presence detectors	Force limitation and photocells or presence detectors

#### RESPONSIBILITIES OF THE INSTALLER

Remember that anyone who sells and/or motorises doors/gates becomes the manufacturer of the automatic door/gate machine and must therefore prepare and conserve a **technical folder** that contains the following documents (see Machinery Directive Enclosure V):

- Assembly drawing of the automatic door/gate;
- Electrical connection and control circuit wiring diagram;
- Risk analysis including: a list of the essential safety requirements provided in Machinery Directive Enclosure I; a list of the risks posed by the door/gate and the description of the solutions adopted.
- Keep these operating instructions in a safe place together with the instructions for all the other components;
- Prepare these operating instructions and general safety warnings (for the completion of these operating instructions) and deliver a copy to the final user;
- Fill out the maintenance register and deliver a copy to the final user;
- Fill out the complete CE label or plate and apply it to the door/gate.

Note: The technical folder must be conserved for inspection by the competent national authorities for at least ten years from the date construction of the automatic door/gate.





**Esempio di installazione tipica - Example of typical installation - Exemple d'installation typique**  
**Ejemplo de instalación típica - Exemplo de instalação típica**

**DEA** System fornisce queste indicazioni che si possono ritenere valide per un impianto tipo ma che non possono essere complete. Per ogni automatismo, infatti, l'installatore deve valutare attentamente le reali condizioni del posto ed i requisiti dell'installazione in termini di prestazioni e di sicurezza; sarà in base a queste considerazioni che redigerà l'analisi dei rischi e progetterà nel dettaglio l'automatismo.

**DEA** System provides the following instructions which are valid for a typical system but obviously not complete for every system. For each automatism the installer must carefully evaluate the real conditions existing at the site. The installation requisites in terms of both performance and safety must be based upon such considerations, which will also form the basis for the risk analysis and the detailed design of the automatism.

**DEA** System fournit ces indications que vous pouvez considérer comme valables pour une installation-typique, même si elles ne peuvent pas être complètes. En effet, pour chaque automatisation, l'installateur doit évaluer attentivement les conditions réelles du site et les pré-requis de l'installation au point de vue

performances et sécurité ; c'est sur la base de ces considérations qu'il rédigera l'analyse des risques et qu'il concevra l'automatisation d'une manière détaillée.

**DEA** System facilita estas indicaciones que pueden considerarse válidas para una instalación tipo pero que no pueden considerarse completas. El instalador, en efecto, tiene que evaluar atentamente para cada automatismo las reales condiciones del sitio y los requisitos de la instalación por lo que se refiere a prestaciones y seguridad; en función de estas consideraciones redactará el análisis de riesgos y efectuará el proyecto detallado del automatismo.

**DEA** System fornece estas indicações que podem ser consideradas válidas para o equipamento padrão, mas que podem não ser completas. Para cada automatismo praticamente o técnico de instalação deverá avaliar com atenção as condições reais do sítio e os requisitos da instalação em termos de performance e de segurança; será em função destas considerações que realizará uma análise dos riscos e projectará o

Per un corretto uso ai fini della sicurezza il motore deve essere collegato unicamente ad una centrale di comando Dea System.

To ensure proper and safe use of operators, connect them only to Dea System control panels.

Afin d'assurer un emploi correct au point de vue de la sécurité, le moteur doit être branché à une armoire de commande Dea System.

Para un empleo correcto en cuanto a seguridad, el motor tiene que conectarse exclusivamente a una central de control Dea System.

Para um uso certo em relação à segurança, o motor deve ser ligado unicamente a uma central de comando Dea System.

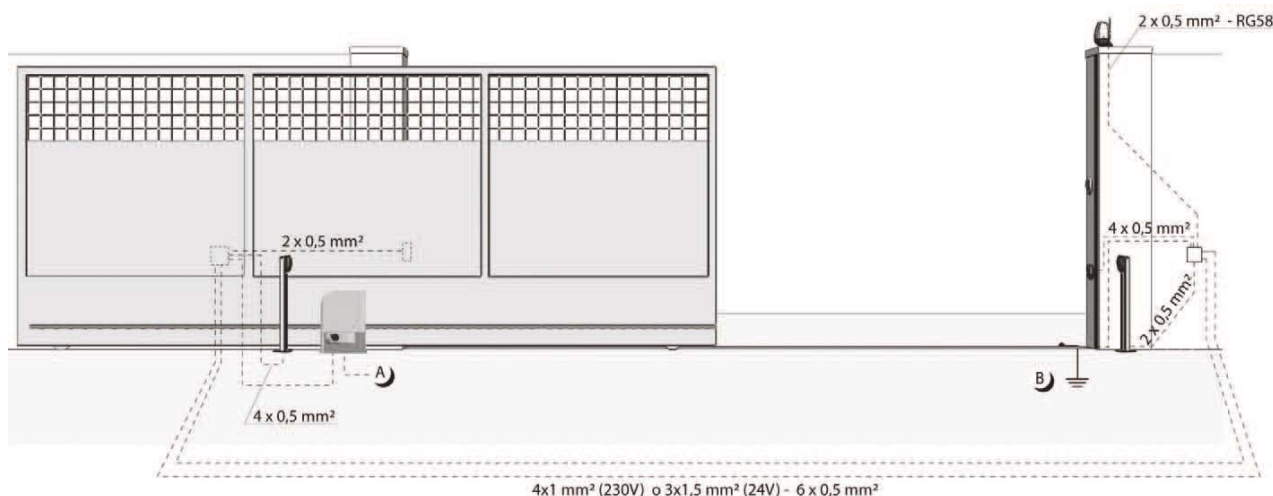

- A)** Collegarsi alla rete 230 V  $\pm$  10% 50-60 Hz tramite un interruttore onnipolare o altro dispositivo che assicuri la onnipolare disinserzione della rete, con una distanza di apertura dei contatti  $\geq$  3 mm  
Make the 230V  $\pm$  10% 50-60 Hz mains connection using an omnipolar switch or any other device that guarantees the omnipolar disconnection of the mains network with a contact opening distance of 3 mm  
Connectez-vous au réseau 230 V  $\pm$  10% 50-60 Hz au moyen d'un interrupteur omnipolaire ou d'un autre dispositif qui assure le débranchement omnipolaire du réseau, avec un écartement des contacts égal à 3 mm.  
Efectuar la conexión a una línea eléctrica 230 V  $\pm$  10% 50-60 Hz a través de un interruptor omnipolar u otro dispositivo que asegure la onnipolar desconexión de la línea, con 3 mm de distancia de apertura de los contactos.  
Ligue na rede de 230 V.  $\pm$  10% 50-60 Hz mediante um interruptor onnipolar ou outro dispositivo que assegure que se desliga de maneira onnipolar da rede, com abertura dos contactos de pelo menos 3 mm. de distância
- B)** Collegare a terra tutte le masse metalliche - All metal parts must be grounded - Connectez toutes les masses métalliques à la terre - Conectar con la tierra todas las masas metálicas - Realize ligação à terra de todas as massas metálicas



Lista parti ordinabili, Spare parts list, Liste pièces ordonnables, Lista partes que pueden encargarse,  
Lista para pedido de peças de reposição

**cod. 914150R** leva sblocco  
release lever  
levier déverrouillage  
palanca de desbloqueo  
alavanca de desbloqueio

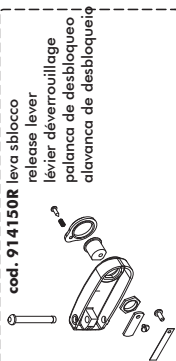

**cod. 914040E** moisetto+piastrella  
terminal board  
bomier  
bomera  
caixa de terminais

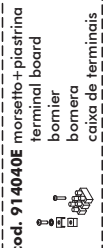

**cod. 360440** ingranaggio - art. non rev.  
gear - art. not rev.  
engrenaje - art. non rev.  
engranaje - art. no rev.  
engrenagem - art. não rev.  
engrenagem - art. rev.  
gear - art. rev.  
engrenaje - art. rev.  
engranaje - art. rev.  
engrenagem - art. rev.

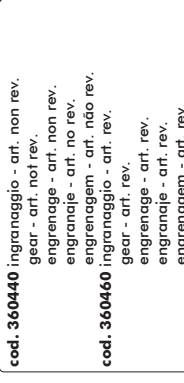

**cod. 914110N** sblocco interno - art. non rev.  
internal unlocking device - art. not rev.  
déverrouillage intérieur - art. non rev.  
desbloqueo interno - art. no rev.  
desbloqueio interno - art. não rev.  
sblocco interno - art. 6/24  
internal unlocking device - art. 6/24  
déverrouillage intérieur - art. 6/24  
desbloqueo interno - art. 6/24  
desbloqueio interno - art. 6/24

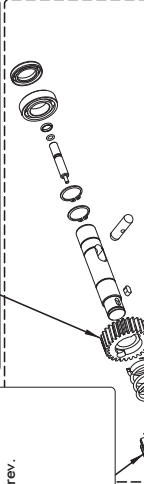

**cod. 915112N** sblocco interno - art. rev.  
internal unlocking device - art. rev.  
déverrouillage intérieur - art. rev.  
desbloqueo interno - art. rev.  
desbloqueio interno - art. rev.

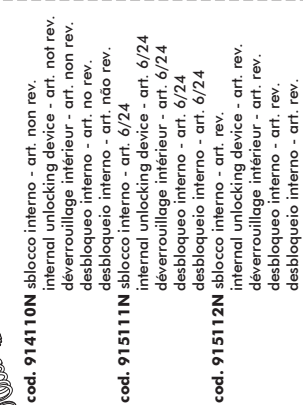

**cod. 310650** cassa riduttore  
gearmotor casing  
caisson reducteur  
caixa do redutor

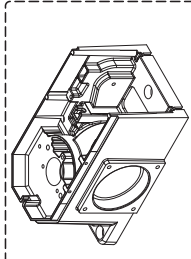

**cod. 121016** cuscinetto  
bearing  
cousinet  
cojinete  
rolamento

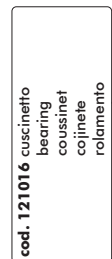

**cod. 157003** anello di tenuta  
choke ring  
anneau d'étanchéité  
anillo aislador  
anel de vedação

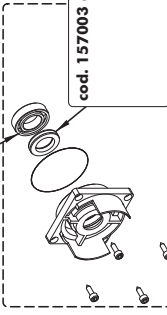

**cod. 9141200** flangia laterale  
side flange  
brida lateral  
brida lateral  
flange lateral

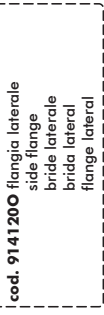

**cod. 360480** ingranaggio Z16 - art. non rev.  
Z16 gear - art. not rev.  
engrenaje Z16 - art. non rev.  
engranaje Z16 - art. no rev.  
engrenagem Z16 - art. não rev.  
ingranagem Z13 - art. rev.  
Z13 gear - art. rev.  
engrenaje Z13 - art. rev.  
engranaje Z13 - art. rev.  
engrenagem Z13 - art. rev.

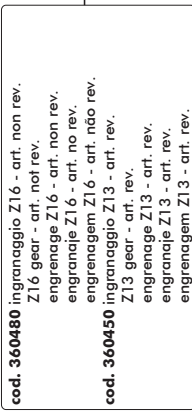

**cod. 679130** cassetta in ABS  
panel box  
boite porte cadre  
caja porta cuadro  
caixa porta quadro

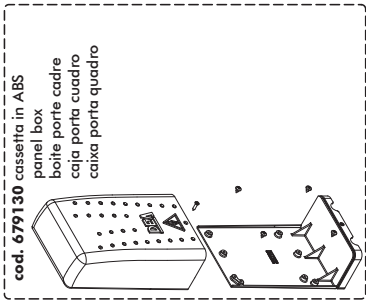

**cod. 914070H** scudi motore - art. 400  
motor barrier - art. 400  
protection moteur - art. 400  
escudo por motor - art. 400  
escudo motor - art. 400  
**cod. 915070H**  
motor barrier - art. 800  
protection moteur - art. 800  
escudo por motor - art. 800  
escudo motor - art. 800

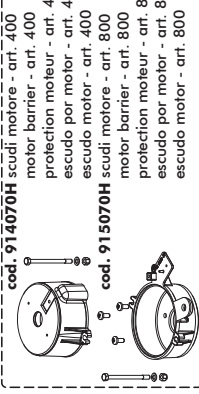

**cod. 393026** statore - art. 400  
stator - art. 400  
stator - art. 400  
estator - art. 400  
**cod. 393042** statore - art. 800 non rev.  
stator - art. 800 not rev.  
stator - art. 800 non rev.  
estator - art. 800 no rev.  
**cod. 393043** statore - art. 800 não rev.  
stator - art. 800 rev.  
stator - art. 800 rev.  
estator - art. 800 rev.  
estator - art. 800 rev.

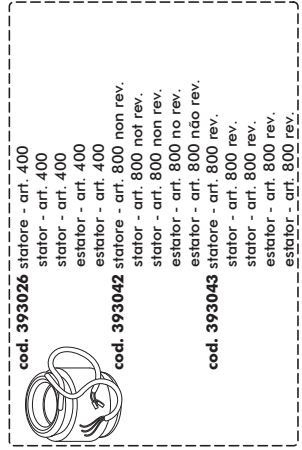

**cod. 914050F** encoder  
encoder  
encoder  
encoder

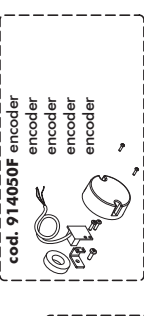

**cod. 914020C** base di fondazione  
foundation plate  
plaque de fondation  
base de cimentados  
base da fundação

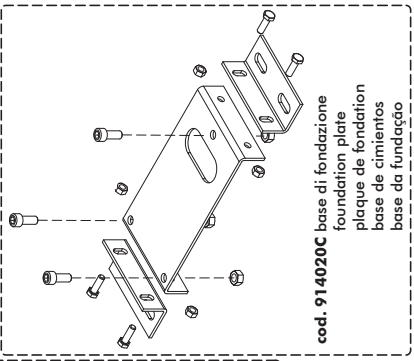

**cod. 914080I** albero motore - art. 6RR  
motor shaft - art. 6RR  
arbre moteur - art. 6RR  
eje motor - art. 6RR  
veio de motor - art. 6RR  
**cod. 915080I** albero motore - art. 9RR - non rev.  
motor shaft - art. 9RR - not rev.  
arbre moteur - art. 9RR - non rev.  
eje motor - art. 9RR - no rev.  
veio de motor - art. 9RR - não rev.  
**cod. 915081I** albero motore - art. 9RR - rev.  
motor shaft - art. 9RR - rev.  
arbre moteur - art. 9RR - rev.  
eje motor - art. 9RR - rev.  
veio de motor - art. 9RR - rev.

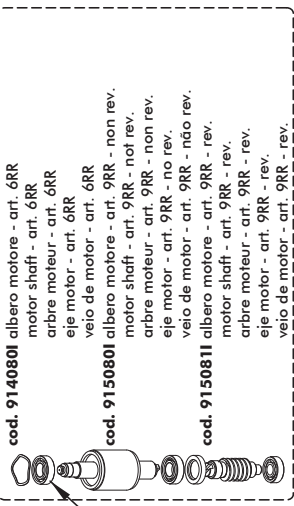

**cod. 914000A** camme finecorsa  
limit switch cam  
camme fin de course  
leva tope del recorrido  
limite do fim de curso

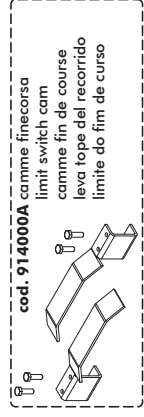

**cod. 914030D** condensatore - art. 400  
capacitor - art. 400  
condensateur - art. 400  
condensador - art. 400  
**cod. 915030D** condensatore - art. 800  
capacitor - art. 800  
condensateur - art. 800  
condensador - art. 800



**cod. 677030** centrale di comando - art. 401/801  
control board - art. 401/801  
armoire de commande - art. 401/801  
central de mando - art. 401/801  
**cod. 677070** centrale di comando - art. 6RR/9RR  
control board - art. 6RR/9RR  
armoire de commande - art. 6RR/9RR  
central de mando - art. 6RR/9RR  
quadro de comando - art. 6RR/9RR  
**cod. 677110** centrale di comando - art. 403E  
control board - art. 403E  
armoire de commande - art. 403E  
central de mando - art. 403E  
**cod. 678090** centrale di comando - art. 3/24RR-6/24RR  
control board - art. 3/24RR-6/24RR  
armoire de commande - art. 3/24RR-6/24RR  
quadro de comando - art. 3/24RR-6/24RR

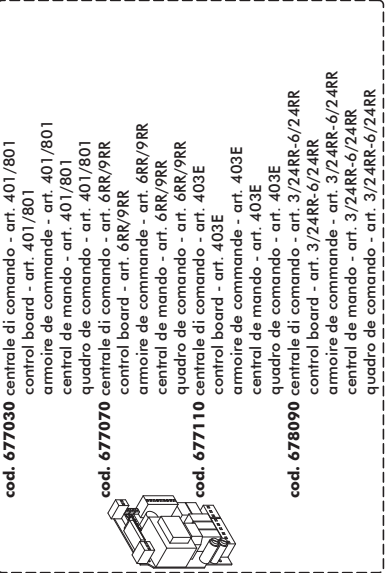

**cod. 914010B** piastra finecorsa  
limit switch bracket  
attache fin de course  
conexión final de carrera  
suporte fim de curso

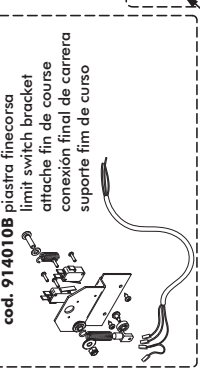

**cod. 121407** cuscinetto  
bearing  
cousinet  
cojinete  
rolamento

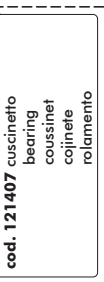



Lista parti ordinabili, Spare parts list, Liste pièces ordonnables, Lista partes que pueden encargarse,  
Lista para pedido de peças de reposição



**cod. 121418** cuscinetto  
bearing  
coussinet  
cojinete  
rolamento

**cod. 9140811** albero motore con frizione mec. - art. 6RR  
motor shaft with mechanical clutch - art. 6RR  
arbre moteur avec embrayage mécanique - art. 6RR  
eje motor con embrague mecánico - art. 6RR  
veio de motor com fricção mecânica - art. 6RR

**cod. 9150821** albero motore con frizione mec. - art. 9RR - non rev.  
motor shaft with mechanical clutch - art. 9RR - not rev.  
arbre moteur avec embrayage mécanique - art. 9RR - non rev.  
eje motor con embrague mecánico - art. 9RR - no rev.  
veio de motor com fricção mecânica - art. 9RR - não rev.

**cod. 9150831** albero motore con frizione mec. - art. 9RR - rev.  
motor shaft with mechanical clutch - art. 9RR - rev.  
arbre moteur avec embrayage mécanique - art. 9RR - rev.  
eje motor con embrague mecánico - art. 9RR - rev.  
veio de motor com fricção mecânica - art. 9RR - rev.

**cod. 175000** batterie  
battery  
batterie  
baterias



**cod. 470420** supporto trasformatore  
transformer support  
support transformeur  
soporte transformador  
suporte transformador

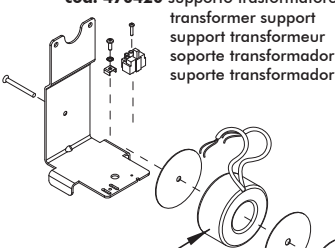

**cod. 914140Q** carter motore  
case  
carter  
carter  
tampa

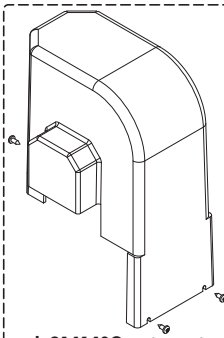

**cod. 162102** trasformatore  
transformer  
transformeur  
transformador  
transformador

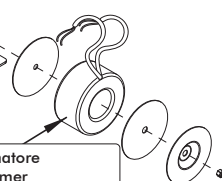

**cod. 914200Z** motore 24V + vite senza fine  
24V motor + worm screw  
moteur 24V + vis sans fin  
motor 24V + tornillo sinfin  
motor de 24V + parafuso sem fim

**cod. 914201Z** motore 24V 100W + vite senza fine  
24V motor 100W + worm screw  
moteur 24V 100W + vis sans fin  
motor 24V 100W + tornillo sinfin  
motor de 24V 100W + parafuso sem fim

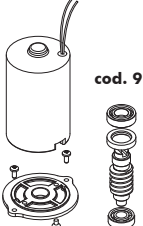



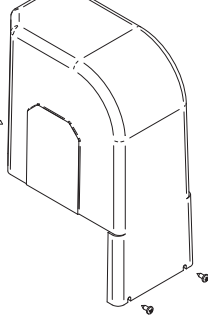

**cod. 914190V** carter motore  
case  
carter  
carter  
tampa



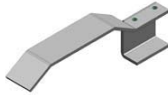

**Contenuto dell'imballo**  
**Contents of the package**  
**Contenu de l'emballage**  
**Contenido del embalaje**  
**Conteúdo da embalagem**

	x1		x1		x1		x1		x4
---	----	---	----	---	----	--	----	---	----

**F1 Elementi del prodotto, Product elements, Eléments du produit, Elementos del producto, Elementos do produto**

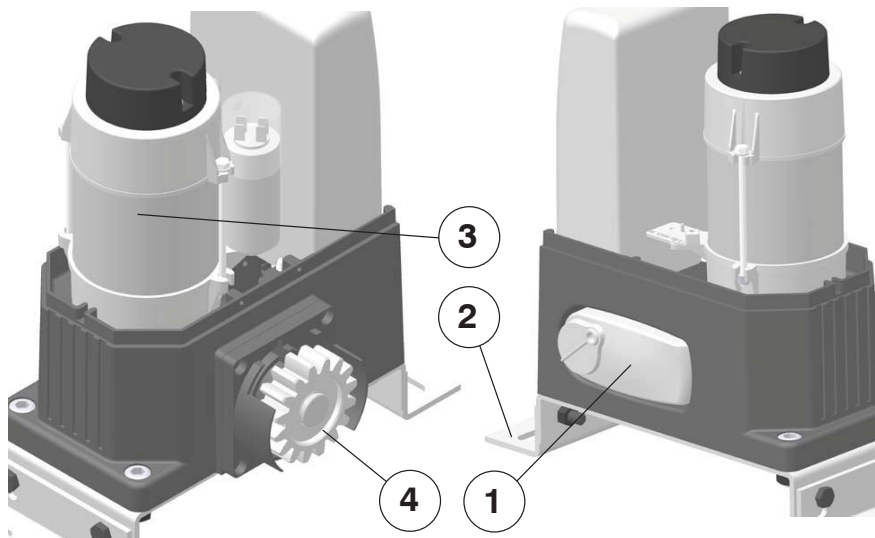

- |   |   |
|---|---|
| 1<br>Maniglia di sblocco<br>Release handle<br>Poigné de déverrouillage<br>Manilla desbloqueo<br>Puxador desbloqueio | 2<br>Base di fondazione<br>Foundation base<br>Base de fondation<br>Base de cimientos<br>Base da fundação      |
| 3<br>Gruppo motore<br>Motor unit<br>Groupe moteur<br>Grupo motor<br>Grupo do motor                                  | 4<br>Ingranaggio traino<br>Draft gear<br>Engrenage de traction<br>Engranaje arrastre<br>Engranagem de arrasto |

**F4 Installazione e regolazione finecorsa, Limit switch installation and adjustment, Installation et réglage fin de course, Instalación y regulación del sensor de tope, Instalação e regulação fim de curso**

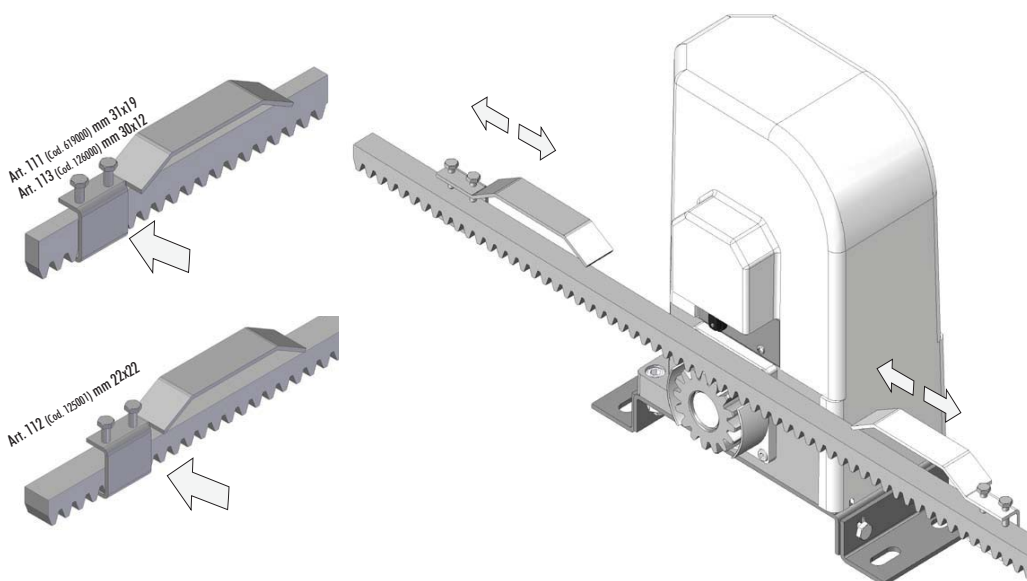



**F2** Ingombri prodotto, Product dimensions, Cotes d'encombrement du produit,  
Espacio ocupado por el producto, Medidas máximas do produto

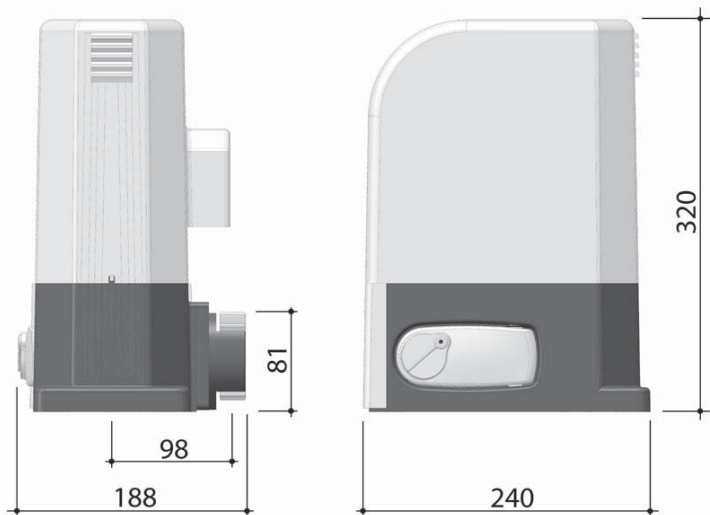

**F3** Misure intallazione, Installation  
measurements, Mesures pour l'installa-  
tion, Medidas instalación, Medidas para  
instalação

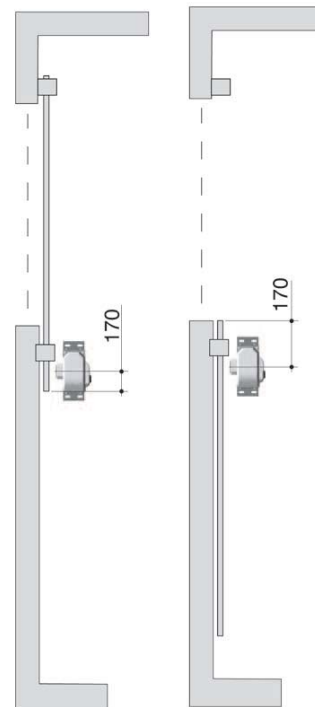

**F5** Posizione etichetta, Label position, Position étiquette,  
Posición etiqueta, Posição da etiqueta

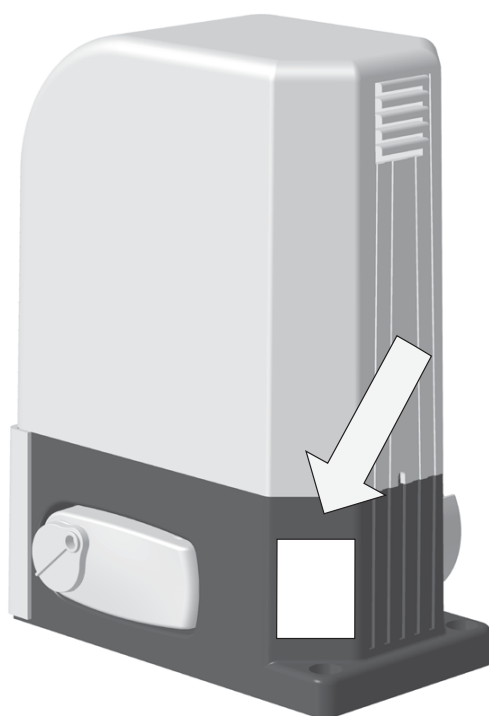

**F6** Regolazione frizione, Mechanical  
clutch adjustment, Réglage de l'em-  
brayage mécanique, Regulación del  
embrague mecánico, Regulação fricção  
mecânica

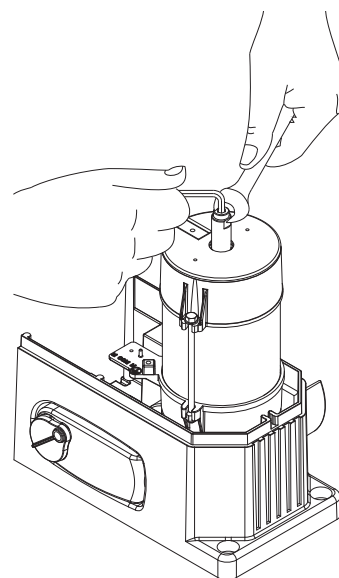



**F7** Assemblaggio riduttore, Gear motor assembly, Assemblage réducteur, Montaje del reductor, Ensamblagem reductor

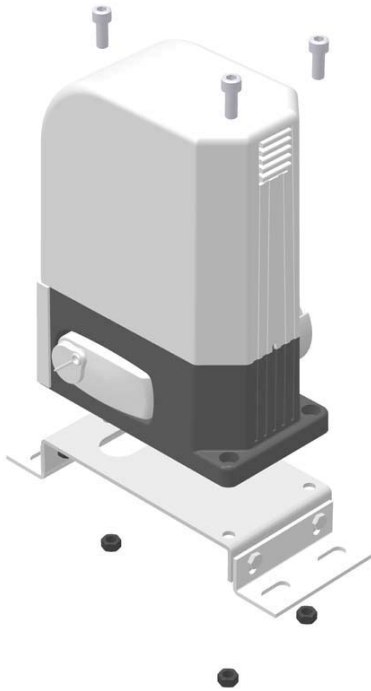

**F8** Installazione base, Basic installation, Installation de base, Instalación básica, Instalação base

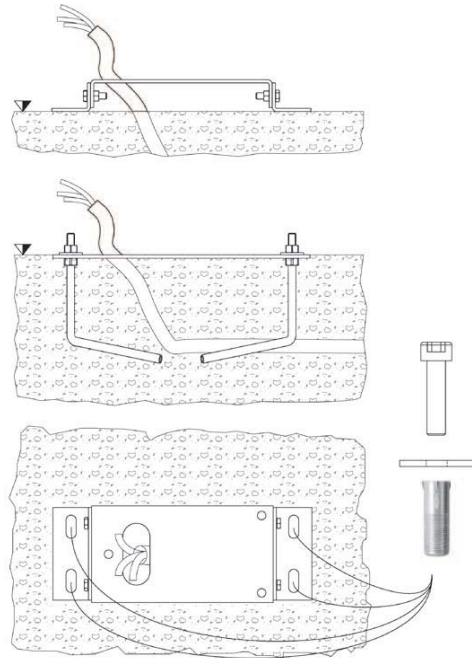

**F9** Sblocco manuale, Manual release, Déverrouillage manuel, Desbloqueo manual, Desbloqueo manual

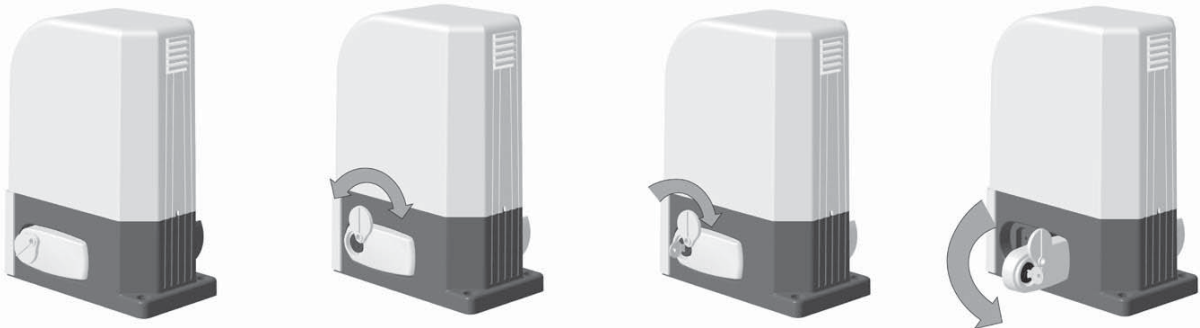

**F10** Distanze antischiacciamento, Crushing prevention safety distances, Distances anti-écrasement, Distancias anti aplastamiento, Distância para evitar esmagamento

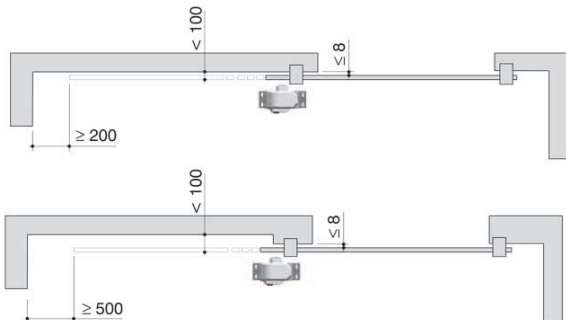

**F11** Verifica funzionamento fotocellule, Check photocells working, Contrôle du fonctionnement des photocellules, Control del funcionamiento de las fotocélulas, Verificação funcionamento fotocélulas

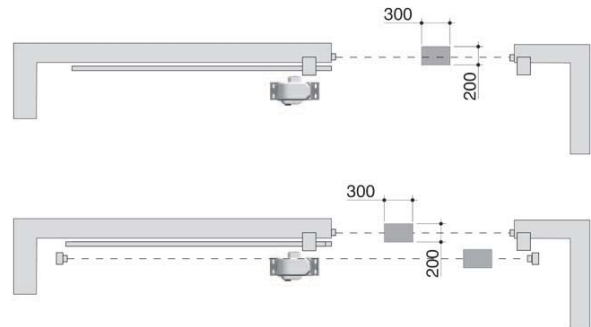

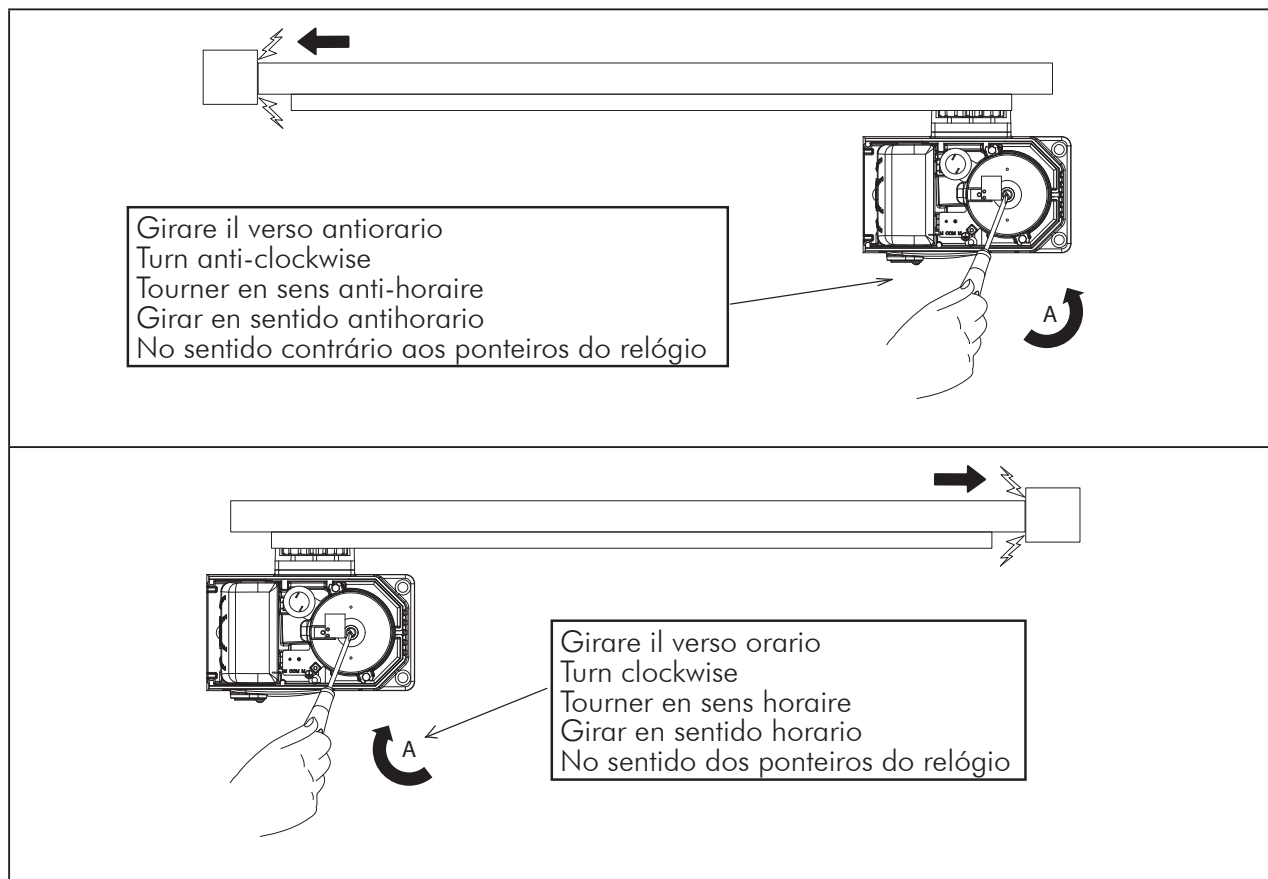

Nel caso in cui il cancello si dovesse bloccare, e non fosse possibile azionare la leva di sblocco, procedere come segue:

- Svitare le viti e togliere il carter del motore;
- Svitare le viti e togliere la copertura encoder;
- Agire con un cacciavite sull'apposito intaglio presente nell'albero motore e girare (A) come in figura.

If the gate stops, and there's no possibility to operate on the unlocking lever, proceed as follows:

- Unscrew the screws and take the operator carter off;
- Unscrew the screws and take the encoder cover;
- By the use of a screwdriver turn (A) the operator shaft notch as shown in the picture.

Si le moteur s'arrête et il n'y a aucune possibilité de déverrouiller, procéder comme il suit:

- dévisser les visses et enlever le capot du moteur;
- dévisser les visses et enlever le capot de l'encodeur;
- tourner la gravure (A) présente sur l'arbre moteur comme montré en figure en utilisant un tournevis.

En el caso en el que la puerta se deba desbloquear, y no fuese posible accionar la leva de desbloqueo proceder como sigue:

- Desenroscar los tornillos o cortar el carter del motor;
- Desenroscar los tornillos o cortar la cobertura del encogor;
- Accionar mediante una llave fija en el eje que sale de la bobina del motor y girar (A) como en el dibujo.

No caso de ser necesario desbloquear a porta e não seja possível activar a alavanca de desbloqueio do motor, proceder do seguinte modo:

- Desapertar os parafusos do carter e retirá-lo;
- Desapertar os parafusos da Tampa do encoder e retirá-lo;
- Com uma chave de fendas, girar (A) o rotor do motor no sentido indicado na figura.

## Art. 460

**“Eseguire** il montaggio dei particolari come fig. 1 e praticare la gettata con cemento assicurando una posizione perfettamente orizzontale della piastra P4. Dopo l’essiccazione svitare P2 e P3 e montare base di fondazione come rappresentato in fig. 2” - **Assemble** the parts as illustrated in Fig. 1 and pour cement while ensuring a perfectly horizontal position of P4 plate. Once dry, unscrew P2 and P3 and install the foundation base as illustrated in Fig. 2. - **Exécutez** le montage des pièces comme illustré dans la Fig. 1 et faites la coulée de ciment en assurant une position absolument horizontale de la plaque P4. Une fois sèche, dévissez P2 et P3 et montez la base de fondation comme il est illustré dans la Fig. 2. - **Realizar** el montaje de las piezas como en la fig. 1 y practicar la colada con cemento asegurando una

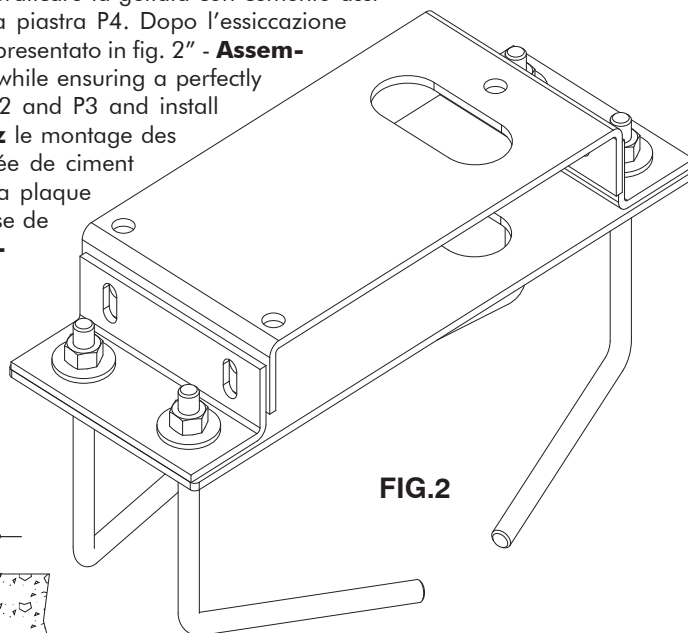
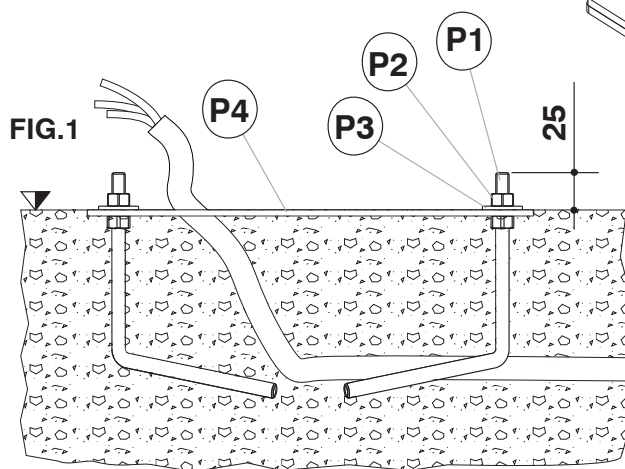

posición perfectamente horizontal de la placa P4. Una vez seco, destornillar P2 y P3 y montar la base de cimientos como representado en la fig. 2” - **Efectue** a montagem das peças como indicado na fig. 1 e deite o cimento de maneira que se assegure à da chapa P4 uma posição perfeitamente horizontal. Depois que tiver enxugado, desatarraxe P2 e P3 e monte a base da fundação da maneira apresentada na fig. 2.”

Questo manuale è stato realizzato utilizzando carta ecologica riciclata certificata Ecolabel per contribuire alla salvaguardia dell’ambiente.

This manual was printed using recycled paper certified Ecolabel to help save the environment.

Ce manuel a été réalisé en utilisant du papier recyclé certifié Ecolabel afin de respecter l’environnement.

El manual ha sido fabricado utilizando papel reciclado certificado Ecolabel para preservar el medio ambiente.

Este manual foi impresso com papel reciclado certificado Ecolabel para ajudar a preservar o meio ambiente.

# DEA<sup>®</sup>

DEA SYSTEM S.p.A. - Via Della Tecnica, 6 - ITALY - 36013 PIOVENE ROCCHETTE (VI)  
tel. +39 0445 550789 - fax +39 0445 550265 - Internet <http://www.deasystem.com> - e-mail: [deasystem@deasystem.com](mailto:deasystem@deasystem.com)