

Owner's Manual & Safety Instructions

BILT HARD

**301CC OHV
HORIZONTAL
SHAFT GAS ENGINE**

TL-EG-301

⚠ DANGER

Using an engine indoors **CAN KILL YOU IN MINUTES.**

Engine exhaust contains carbon monoxide. This is a poison you cannot see or smell.

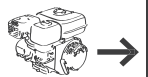

NEVER use inside a home or garage, **EVEN IF** doors and windows are open.

Only use **OUTSIDE** and far away from windows, doors, and vents.

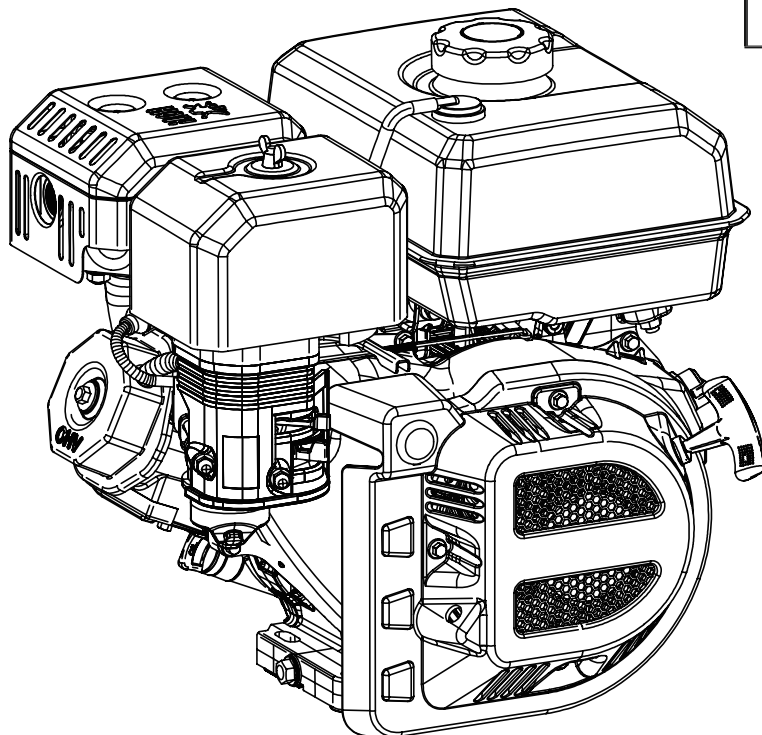

Save This Manual Keep this manual for the safety warnings and precautions, assembly, operating, inspection, maintenance and cleaning procedures. Write the product's serial number in the back of the manual near the assembly diagram (or month and year of purchase if product has no number). Keep this manual and the receipt in a safe and dry place for future reference.

Thank you for ordering our product. If you have any issue, please email it and your order ID to inquiry@bilthardusa.com or call (888)680-2849.

Table of Contents

Specifications	2	Maintenance	12
Safety	3	Troubleshooting	16
Setup	6	Warranties	18
Operation	8	Parts Lists and Diagrams	20





Specifications

Displacement		301cc
Engine Type		Horizontal Single Cylinder 4-stroke OHV
Cooling System		Forced air cooled
Fuel	Type	87+ octane stabilizer treated unleaded gasoline
	Capacity	4.6L/1.2 Gallon
Engine Oil	Type SAE	10W-30 above 32° F 5W30 at 32° F or below
	Capacity	1.16 Quart
Run Time @ 50% Load with full tank		4 hr.
Sound Level		106 dB
Bore x Stroke		80 mm x 60 mm
Compression Ratio		8.2:1
Rotation viewed from PTO (power takeoff - the output shaft)		Counterclockwise
Spark Plug	Type	F6TC
	Gap	0.027" - 0.031"
Valve Clearance	Intake	0.004" - 0.006"
	Exhaust	0.006" - 0.008"
Speed	Idle	1600 ±300 RPM
Shaft	Shaft	Ø1" x 3.48"
	Keyway	0.25"
	End Tapped	7/16" - 20 UNF



The emissions control system for this Engine is warranted for standards set by the U.S. Environmental Protection Agency. For warranty information, refer to the last pages of this manual.



BILT HARD

WARNING SYMBOLS AND DEFINITIONS

	This is the safety alert symbol. It is used to alert you to potential personal injury hazards. Obey all safety messages that follow this symbol to avoid possible injury or death.
	Indicates a hazardous situation which, if not avoided, will result in death or serious injury.
	Indicates a hazardous situation which, if not avoided, could result in death or serious injury.
	Indicates a hazardous situation which, if not avoided, could result in minor or moderate injury.
	Addresses practices not related to personal injury.

Symbol Definitions

Symbol	Property or Statement
RPM	Revolutions Per Minute
HP	Horsepower
	WARNING marking concerning Risk of Eye Injury. Wear ANSI-approved safety goggles with side shields.
	Read the manual before set-up and/or use.
	WARNING marking concerning Risk of Hearing Loss. Wear hearing protection.

Symbol	Property or Statement
	WARNING marking concerning Risk of Respiratory Injury. Operate engine OUTSIDE and far away from windows, doors, and vents.
	WARNING marking concerning Risk of Fire while handling fuel. Do not smoke while handling fuel.
	WARNING marking concerning Risk of Fire. Do not refuel while operating. Keep flammable objects away from engine.

IMPORTANT SAFETY INSTRUCTIONS



WARNING! Read all instructions.

Failure to follow all instructions listed below may result in fire, serious injury and/or DEATH.

The warnings and precautions discussed in this manual cannot cover all possible conditions and situations that may occur. It must be understood by the operator that common sense and caution are factors which cannot be built into this product, but must be supplied by the operator.

SAVE THESE INSTRUCTIONS

Set up Precautions

1. Gasoline fuel and fumes are flammable, and potentially explosive. Use proper fuel storage and handling procedures. Do not store fuel or other flammable materials nearby.
2. Have multiple ABC class fire extinguishers nearby.
3. Operation of this equipment may create sparks that can start fires around dry vegetation. A spark arrestor may be required. The operator should contact local fire agencies for laws or regulations relating to fire prevention requirements.
4. Set up and use only on a flat, level, well-ventilated surface.
5. Wear ANSI-approved safety goggles, heavy-duty work gloves, and dust mask/respirator during set up.
6. Use only lubricants and fuel recommended in the Specifications chart of this manual.

Operating Precautions

1.  **CARBON MONOXIDE HAZARD**
Using an engine indoors
CAN KILL YOU IN MINUTES.
Engine exhaust contains carbon monoxide. This is a poison you cannot see or smell.

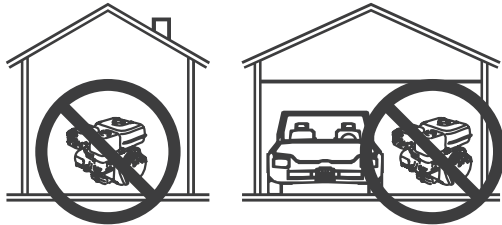

NEVER use inside a home or garage, EVEN IF doors and windows are open.

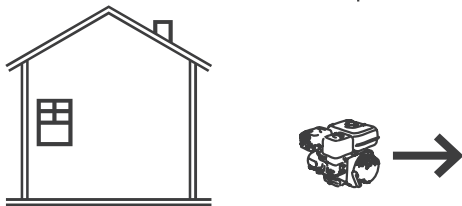

Only use OUTSIDE and far away from windows, doors, and vents.

2. Keep children away from the equipment, especially while it is operating.
3. Keep all spectators at least six feet from the Engine during operation.
4. Fire Hazard! Do not fill gas tank while engine is running. Do not operate if gasoline has been spilled. Clean spilled gasoline before starting engine. Do not operate near pilot light or open flame.
5. Do not touch engine during use. Let engine cool down after use.
6. Never store fuel or other flammable materials near the engine.
7. Only use a suitable means of transport and lifting devices with sufficient weight bearing capacity when transporting the engine.
8. Secure the engine on transport vehicles to prevent it from rolling, slipping, and tilting.
9. Industrial applications must follow OSHA requirements.
10. Do not leave the engine unattended when it is running. Turn off the engine (and remove safety keys, if available) before leaving the work area.
11. The engine can produce high noise levels. Prolonged exposure to noise levels above 85 dBA is hazardous to hearing. Wear ear protection when operating the engine or when working nearby while it is operating.
12. Wear ANSI-approved safety glasses and hearing protection during use.
13. People with pacemakers should consult their physician(s) before use. Electromagnetic fields in close proximity to a heart pacemaker could cause pacemaker interference or pacemaker failure. Caution is necessary when near the engine's magneto or recoil starter.
14. Use only accessories that are recommended by Bilt Hard for your model. Accessories that may be suitable for one piece of equipment may become hazardous when used on another piece of equipment.
15. Do not operate in explosive atmospheres, such as in the presence of flammable liquids, gases, or dust. Gasoline-powered engines may ignite the dust or fumes.
16. Stay alert, watch what you are doing and use common sense when operating this engine. Do not use while tired or under the influence of drugs, alcohol or medication.
17. Dress properly. Do not wear loose clothing or jewelry. Keep hair, clothing and gloves away from moving parts. Loose clothes, jewelry or long hair can be caught in moving parts.
18. Parts, especially exhaust system components, get very hot during use. Stay clear of hot parts.
19. Do not cover the engine during operation.
20. Keep the engine and surrounding area clean at all times.

Operating Precautions (cont.)

21. Use the equipment, accessories, etc., in accordance with these instructions and in the manner intended for the particular type of equipment, taking into account the working conditions and the work to be performed. Use of the equipment for operations different from those intended could result in a hazardous situation.
22. Do not operate the equipment with known leaks in the engine's fuel system.
23. **WARNING:** This product contains or, when used, produces a chemical known to the State of California to cause cancer and birth defects or other reproductive harm. (California Health & Safety Code § 25249.5, *et seq.*)
24. When spills of fuel or oil occur, they must be cleaned up immediately. Dispose of fluids and cleaning materials as per any local, state, or federal codes and regulations. Store oil rags in a bottom-ventilated, covered, metal container.
25. Keep hands and feet away from moving parts. Do not reach over or across equipment while operating.
26. Before use, check for misalignment or binding of moving parts, breakage of parts, and any other condition that may affect the equipment's operation. **If damaged, have the equipment serviced before using.** Many accidents are caused by poorly maintained equipment.
27. Use the correct equipment for the application. Do not modify the equipment and do not use the equipment for a purpose for which it is not intended.

Service Precautions

1. **Before service, maintenance, or cleaning:**
 - a. Turn the engine switch to its "OFF" position.
 - b. Allow the engine to completely cool.
 - c. Then, remove the spark plug cap from the spark plug.
2. Keep all safety guards in place and in proper working order. Safety guards include muffler, air cleaner, mechanical guards, and heat shields, among other guards.
3. **Do not alter or adjust any part of the equipment or its engine that is sealed by the manufacturer or distributor. Only a qualified service technician may adjust parts that may increase or decrease governed engine speed.**
4. Wear ANSI-approved safety goggles, heavy-duty work gloves, and dust mask/respirator during service.
5. Maintain labels and nameplates on the equipment. These carry important information. If unreadable or missing, contact Bilt Hard for a replacement.
6. Have the equipment serviced by a qualified repair person using only identical replacement parts. This will ensure that the safety of the equipment is maintained. Do not attempt any service or maintenance procedures not explained in this manual or any procedures that you are uncertain about your ability to perform safely or correctly.
7. Store equipment out of the reach of children.
8. Follow scheduled engine and equipment maintenance.

Refueling:

1. Do not smoke, or allow sparks, flames, or other sources of ignition around the equipment, especially when refuelling.
2. Do not refill the fuel tank while the engine is running or hot.
3. **Do not fill fuel tank to the top.** Leave a little room for the fuel to expand as needed. Refuel in a well-ventilated area only.
4. Wipe up any spilled fuel and allow excess to evaporate before starting engine. **To prevent FIRE, do not start the engine while the smell of fuel hangs in the air.**



SAVE THESE INSTRUCTIONS.

Set Up



Read the **ENTIRE IMPORTANT SAFETY INFORMATION** section at the beginning of this manual including all text under subheadings therein before set up or use of this product.

WARNING

TO PREVENT SERIOUS INJURY:

Operate only with proper spark arrestor installed.



Operation of this equipment may create sparks that can start fires around dry vegetation. A spark arrestor may be required.

The operator should contact local fire agencies for laws or regulations relating to fire prevention requirements.

WARNING! DO NOT INSTALL THIS ENGINE ON A VEHICLE.

NOT FOR HIGHWAY USE. FOLLOW ALL APPLICABLE LAWS FOR INSTALLATION AND USE.

WARNING! INSTALL THIS ENGINE ACCORDING TO EQUIPMENT INSTRUCTIONS BEFORE USE.

Components and Controls

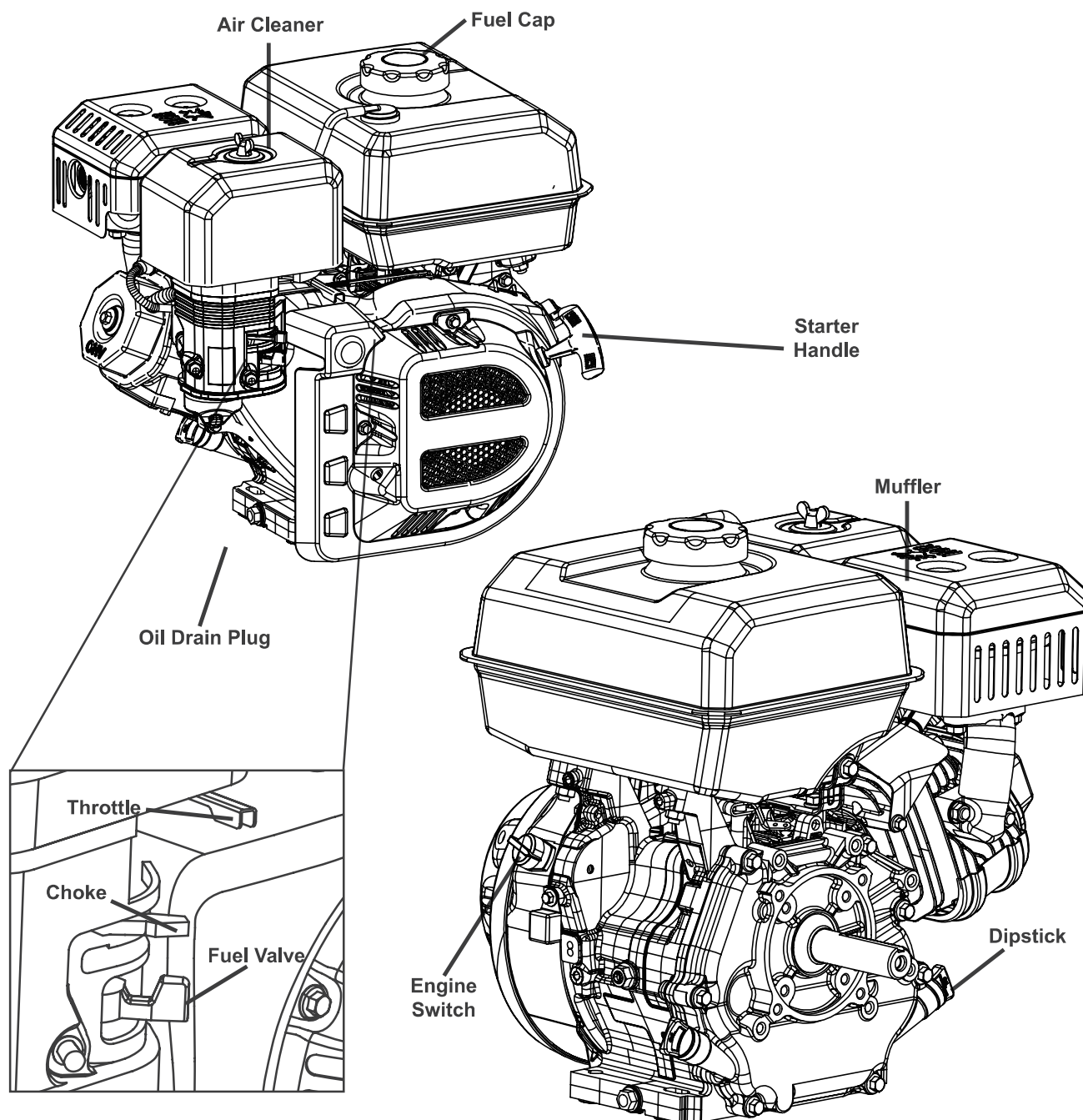

High Altitude Operation Above 3000 feet

⚠WARNING! TO PREVENT SERIOUS INJURY FROM FIRE:

Follow instructions in a well-ventilated area away from ignition sources.

If the engine is hot from use, shut the engine off and wait for it to cool before proceeding. Do not smoke.

At high altitudes, the engine's carburetor, governor (if so equipped), and any other parts that control the fuel-air ratio will need to be adjusted by a qualified mechanic to allow efficient high-altitude use and to prevent damage to the engine and any other devices used with this product. The fuel system on this engine may be influenced by operation at higher altitudes. Proper operation can be ensured by installing an altitude kit at altitudes higher than 3000 ft. above sea level. At elevations above 8000 ft, the engine may experience decreased performance, even with the proper main jet. Operating this engine without the proper altitude kit installed may increase the engine's emissions and decrease fuel economy and performance. The kit should be installed by a qualified mechanic.

1. Turn off the engine.
2. Close the fuel valve.
3. Place a bowl under the fuel cup to catch any spilled fuel.

CAUTION! Carburetor bowl may have gas in it which will leak upon removing the bolt.

4. Unthread the bolt holding the fuel cup.
5. Remove the bolt, Bolt Seal, fuel cup, Fuel Cup Seal and Main Jet from the body of the carburetor assembly.

A carburetor screwdriver (not included) is needed to remove and install the Main Jet.

Note: The mixing tube is held in place by the Main Jet and might fall out when it is removed. If it falls out, replace it in the same orientation before replacing the Main Jet.

NOTICE Warranty void if necessary adjustments are not made for high altitude use.

6. Replace the Main Jet with the replacement Main Jet needed for your altitude range (part 1a or 2a).

Note: The Fuel Cup Seal and Bolt Seal may be damaged during removal and should be replaced with the new ones from the kit.

7. Replace the Fuel Cup Seal (4a), fuel cup, Bolt Seal (3a), and bolt. Tighten in place.

NOTICE: Do not cross thread bolt when tightening. Finger tighten first and then use a wrench to make sure the bolt is properly threaded.

8. Wipe up any spilled fuel and allow excess to evaporate before starting engine. To prevent FIRE, do not start the engine while the smell of fuel hangs in the air.

High Altitude Kit Parts List - A

Part	Description	Qty
1a	Main Jet 3000-6000 ft.	1
2a	Main Jet 6000-8000 ft.	1
3a	Bolt Seal	1

Part	Description	Qty
4a	Fuel Cup Seal	1

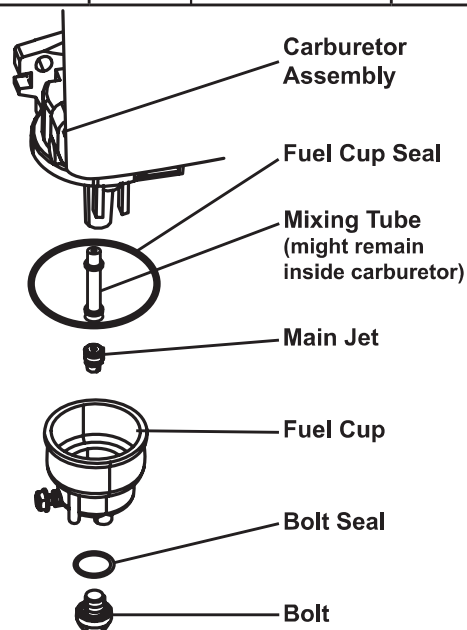



Read the **ENTIRE IMPORTANT SAFETY INFORMATION** section at the beginning of this manual including all text under subheadings therein before set up or use of this product.

Pre-Start Checks

Inspect engine and equipment looking for damaged, loose, and missing parts before set up and starting. If any problems are found, do not use equipment until fixed properly.

Checking and Filling Engine Oil

NOTICE: Your Warranty is VOID if the engine's crankcase is not properly filled with oil before each use. Before each use, check the oil level. Do not run the engine with low or no engine oil. Running the engine with no or low engine oil WILL permanently damage the engine.

1. Make sure the engine is stopped and is level.
2. Close the Fuel Valve.
3. Clean the top of the Dipstick and the area around it. Remove the Dipstick by threading it counterclockwise, and wipe it off with a clean, lint free rag.

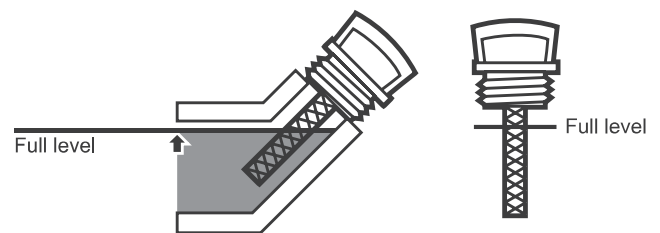

4. Reinsert the Dipstick without threading it in and remove it to check the oil level. The oil level should be up to the full level as shown above.
5. If the oil level is at or below the low mark add the appropriate type of oil until the oil level is at the proper level. SAE 10W-30 oil is recommended for general use. (The SAE Viscosity Grades chart on page 13 in the Service section shows other viscosities to use in different average temperatures.)
6. Thread the dipstick back in clockwise.

NOTICE: Do not run the engine with too little oil. The engine will be permanently damaged.

BILT HARD

Checking and Filling Fuel



⚠ WARNING! TO PREVENT SERIOUS INJURY FROM FIRE:

Fill the fuel tank in a well-ventilated area away from ignition sources. If the engine is hot from use, shut the engine off and wait for it to cool before adding fuel.

Do not smoke.

1. Clean the Fuel Cap and the area around it.
2. Unscrew and remove the Fuel Cap.
3. If needed, fill the Fuel Tank to about 1 inch under the fill neck with 87 octane or higher unleaded gasoline that has been treated with a fuel stabilizer additive. Follow fuel stabilizer manufacturer's recommendations for use.

Note: Do not use gasoline containing more than 10% ethanol (E10). Do not use E85 ethanol.

Note: Do not use gasoline that has been stored in a metal fuel container or a dirty fuel container. It can cause particles to enter the carburetor, affecting engine performance and/or causing damage.

4. Then replace the Fuel Cap.
5. Wipe up any spilled fuel and allow excess to evaporate before starting engine. To prevent FIRE, do not start the engine while the smell of fuel hangs in the air.

Starting the Engine

Before Starting the Engine



Before starting the engine:

- a. Follow the Set Up Instructions in the equipment manual to prepare the equipment.
- b. Inspect the equipment and engine.
- c. Fill the engine with the proper amount and type of both unleaded gasoline and oil.
- d. Read the Equipment Operation section in the equipment manual.

BILT HARD

Manual Start

1. To start a cold engine, move the Choke to the START position.
To restart a warm engine, leave the Choke in the RUN position.

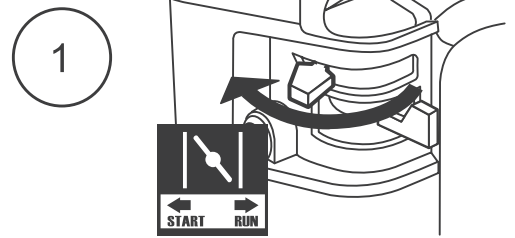

2. Open the Fuel Valve.

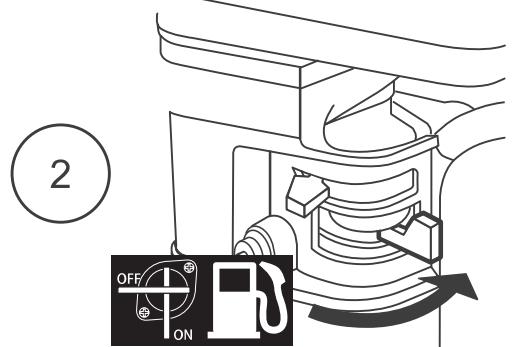

3. Slide the Throttle or Speed Control Lever to 1/3 away from the SLOW position (the "turtle").

Note: Some tools have a Speed Control Lever located elsewhere on the tool which functions the same as the Throttle. Use the Speed Control Lever in place of the Throttle when the tool is so equipped.



4. Turn the Engine Switch on.

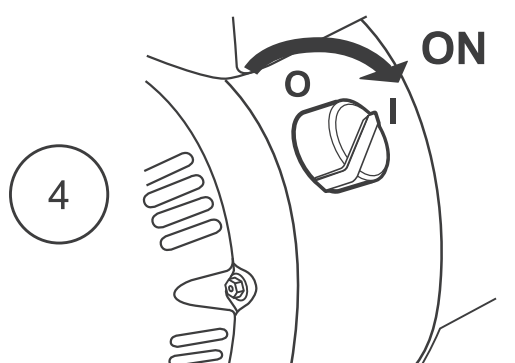
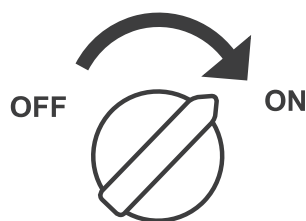

5. Grip the Starter Handle of the Engine loosely and pull it slowly several times to allow the gasoline to flow into the Engine's carburetor. Then pull the Starter Handle gently until resistance is felt. Allow Cable to retract fully and then pull it quickly. Repeat until the engine starts.

Note: Do not let the Starter Handle snap back against the engine. Hold it as it recoils so it doesn't hit the engine.

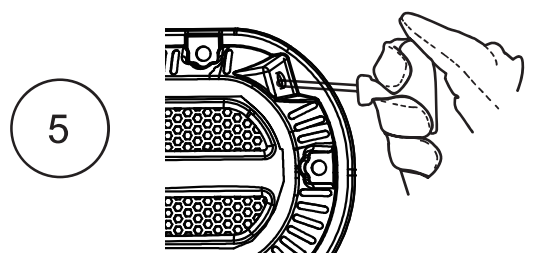

6. Allow the Engine to run for several seconds. Then, if the Choke lever is in the START position, move the Choke Lever very slowly to its RUN position.

Note: Moving the Choke Lever too fast could stall the engine.

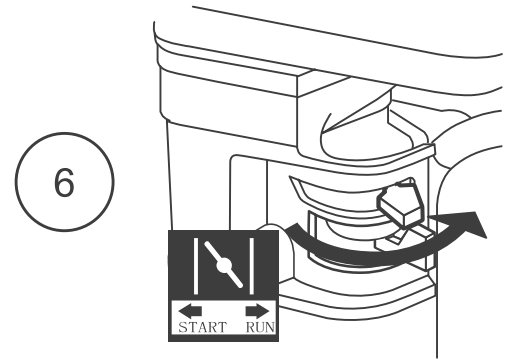

IMPORTANT: Allow the engine to run at no load for five minutes with no load after each start-up so that the engine can stabilize.

7. Adjust the Throttle as needed.

Break-in Period:

- a. Breaking-in the engine will help to ensure proper equipment and engine operation.
- b. The operational break-in period will last about 3 hours of use. During this period:
 - Do not apply a heavy load to the equipment.
 - Do not operate the engine at its maximum speed.
- c. The maintenance break-in period will last about 20 hours of use.
 - Change the engine oil after this period.

Under normal operating conditions subsequent maintenance follows the schedule explained in the MAINTENANCE section.

Stopping the Engine

1. To stop the engine in an emergency, turn the Engine Switch off.
2. Under normal conditions, use the following procedure:
 - a. Slide the Throttle to SLOW (the “turtle”).
 - b. Turn the Engine Switch off.
 - c. Close the Fuel Valve.

NOTICE

Drain fuel at end of season or warranty is void.

See Storage on page 15 for complete storage instructions.

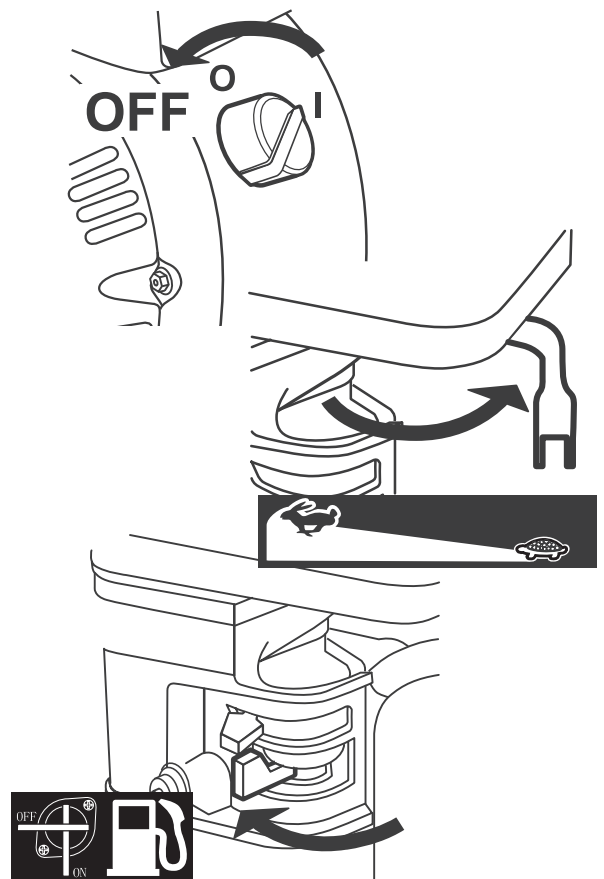

⚠️ WARNING

TO PREVENT SERIOUS INJURY FROM ACCIDENTAL STARTING:

Turn the Power Switch of the equipment to its “OFF” position, wait for the engine to cool, and disconnect the spark plug cap before performing any inspection, maintenance, or cleaning procedures.

TO PREVENT SERIOUS INJURY FROM EQUIPMENT FAILURE:

Do not use damaged equipment. If abnormal noise, vibration, or excess smoking occurs, have the problem corrected before further use.

Follow all service instructions in this manual. The engine may fail critically if not serviced properly.



Many maintenance procedures, including any not detailed in this manual, will need to be performed by a qualified technician for safety. If you have any doubts about your ability to safely service the equipment or engine, have a qualified technician service the equipment instead.

Cleaning, Maintenance, and Lubrication Schedule

Note: This maintenance schedule is intended solely as a general guide. If performance decreases or if equipment operates unusually, check systems immediately. The maintenance needs of each piece of equipment will differ depending on factors such as duty cycle, temperature, air quality, fuel quality, and other factors.

Note: The following procedures are in addition to the regular checks and maintenance explained as part of the regular operation of the engine and equipment.

Procedure	Before Each Use	Monthly or every 20 hr. of use	Every 3 mo. or 50 hr. of use	Every 6 mo. or 100 hr. of use	Yearly or every 300 hr. of use	Every 2 Years
Brush off outside of engine	✓	✓	✓	✓	✓	✓
Check engine oil level	✓	✓	✓	✓	✓	✓
Check air filter			✓	✓	✓	✓
Check deposit cup				✓	✓	✓
Change engine oil		✓		✓	✓	✓
Clean/replace air filter			✓*	✓	✓	✓
Check and clean spark plug				✓	✓	✓
1. Check/adjust idle speed 2. Check/adjust valve clearance 3. Clean fuel tank, strainer and carburetor 4. Clean carbon build-up from combustion chamber					✓**	✓**
Replace fuel line if necessary						✓**

*Service more frequently when used in dusty areas.

**These items should be serviced by a qualified technician.

BILT HARD

Checking and Filling Fuel



⚠️ WARNING! TO PREVENT SERIOUS INJURY FROM FIRE:

Fill the fuel tank in a well-ventilated area away from ignition sources. If the engine is hot from use, shut the engine off and wait for it to cool before adding fuel.

Do not smoke.

1. Clean the Fuel Cap and the area around it.
2. Unscrew and remove the Fuel Cap.
3. If needed, fill the Fuel Tank to about 1 inch under the fill neck with 87 octane or higher unleaded gasoline that has been treated with a fuel stabilizer additive. Follow fuel stabilizer manufacturer's recommendations for use.

Note: Do not use gasoline containing more than 10% ethanol (E10). Do not use E85 ethanol.

Note: Do not use gasoline that has been stored in a metal fuel container or a dirty fuel container. It can cause particles to enter the carburetor, affecting engine performance and/or causing damage.

4. Then replace the Fuel Cap.
5. Wipe up any spilled fuel and allow excess to evaporate before starting engine. To prevent FIRE, do not start the engine while the smell of fuel hangs in the air.

Engine Oil Change

⚠️ CAUTION! Oil is very hot during operation and can cause burns. Wait for engine to cool before changing oil.

1. Make sure the engine is stopped and is level.
2. Close the Fuel Valve.
3. Place a drain pan (not included) underneath the crankcase's drain plug.
4. Remove the drain plug and, if possible, tilt the crankcase slightly to help drain the oil out. Recycle used oil.
5. Replace the drain plug and tighten it.
6. Clean the top of the Dipstick and the area around it. Remove the Dipstick by threading it counterclockwise, and wipe it off with a clean, lint free rag.

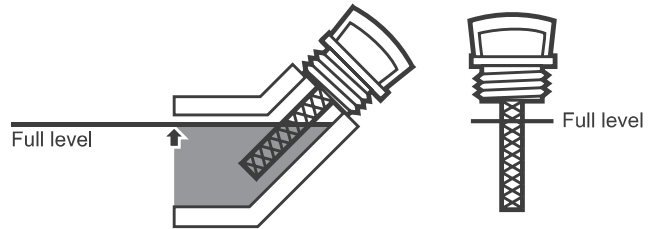

7. Add the appropriate type of oil until the oil level is at the full level. SAE 10W-30 oil is recommended for general use. The SAE Viscosity Grade chart shows other viscosities to use in different average temperatures.

SAE Viscosity Grades

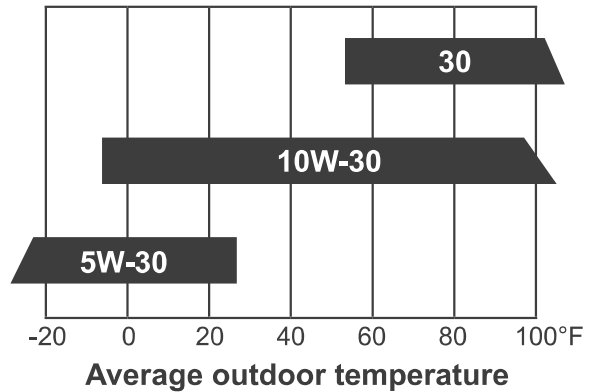

8. Thread the dipstick back in clockwise.

NOTICE: Do not run the engine with too little oil. The engine will be permanently damaged.

Air Filter Element Maintenance

1. Remove the air cleaner cover and the air filter element(s) and check for dirt. Clean as described below.
2. **Cleaning:**
 - For “paper” filter elements:
To prevent injury from dust and debris, wear ANSI-approved safety goggles, NIOSH-approved dust mask/respirator, and heavy-duty work gloves. In a well-ventilated area away from bystanders, use pressurized air to blow dust out of the air filter.
 - For foam filter elements:
Wash the element in warm water and mild detergent several times. Rinse. Squeeze out excess water and allow it to dry completely. Soak the filter in lightweight oil briefly, then squeeze out the excess oil.
3. Install the cleaned filter. Secure the Air Cleaner Cover before use.

Spark Plug Maintenance

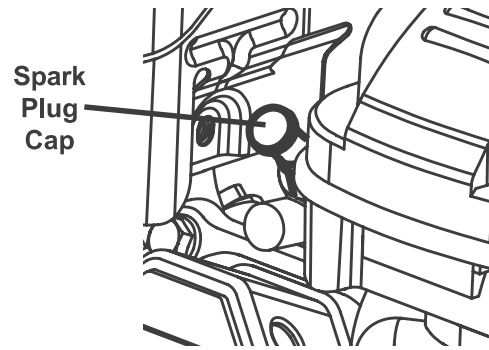

1. Disconnect spark plug cap from end of plug. Clean out debris from around spark plug.
2. Using a spark plug wrench, remove the spark plug.
3. Inspect the spark plug:
If the electrode is oily, clean it using a clean, dry rag. If the electrode has deposits on it, polish it using emery paper. If the white insulator is cracked or chipped, the spark plug needs to be replaced.

Recommended Spark Plugs	
TORCH®	F6TC

NOTICE: Using an incorrect spark plug may damage the engine.

4. When installing a new spark plug, adjust the plug's gap to the specification on the Specifications chart. Do not pry against the electrode, the spark plug can be damaged.
5. Install the new spark plug or the cleaned spark plug into the engine.
 - **Gasket-style:**
Finger-tighten until the gasket contacts the cylinder head, then tighten about 1/2-2/3 turn more.
 - **Non-gasket-style:**
Finger-tighten until the plug contacts the cylinder head, then tighten about 1/16 turn more.

NOTICE: Tighten the spark plug properly. **If loose**, the spark plug will cause the engine to overheat.

If overtightened, the threads in the engine block will be damaged.

6. Apply dielectric spark plug boot protector (not included) to the end of the spark plug and reattach the wire securely.

Storage

When the equipment is to remain idle for longer than 20 days, prepare the Engine for storage as follows:

1. **CLEANING:**

Wait for Engine to cool, then clean Engine with dry cloth. **NOTICE: Do not clean using water.** The water will gradually enter the Engine and cause rust damage. Apply a thin coat of rust preventive oil to all metal parts.

2. **FUEL:**

To protect the fuel tank during storage, fill the tank with gasoline that has been treated with a fuel stabilizer additive. Follow fuel stabilizer manufacturer's recommendations for use. Refer to Checking and Filling Fuel on page 9.



⚠ WARNING! TO PREVENT SERIOUS INJURY FROM FIRE:

Fill tank in a well-ventilated area away from ignition sources. If the engine is hot from use, shut the engine off and wait for it to cool before adding fuel. Do not smoke.

3. **LUBRICATION:**

- a. Change engine oil.
- b. Clean out area around spark plug.
Remove spark plug and pour one tablespoon of engine oil into cylinder through spark plug hole.

- c. Replace spark plug, but leave spark plug cap disconnected.
- d. Pull Starter Handle to distribute oil in cylinder. Stop after one or two revolutions when you feel the piston start the compression stroke (when you start to feel resistance).

4. **STORAGE AREA:**

Cover and store in a dry, level, well-ventilated area out of reach of children. Storage area should also be away from ignition sources, such as water heaters, clothes dryers, and furnaces.

NOTICE: During extended storage periods the Engine must be started every 3 months and allowed to run for 15–20 minutes or the Warranty is VOID.

5. **AFTER STORAGE:**

Before starting the Engine during or after storage, keep in mind that untreated gasoline will deteriorate quickly. Drain the fuel tank and change to fresh fuel if untreated gasoline has been sitting for a month, if treated gasoline has been sitting beyond the fuel stabilizer's recommended time period, or if the Engine does not start.

BILT HARD

Troubleshooting

Problem	Possible Causes	Probable Solutions
Engine will not start	<p>FUEL RELATED:</p> <ol style="list-style-type: none"> No fuel in tank or fuel valve closed. Choke not in START position, cold engine. Gasoline with more than 10% ethanol used. (E15, E20, E85, etc.) Low quality or deteriorated, old gasoline. Carburetor not primed. Dirty fuel passageways. Carburetor needle stuck. Fuel can be smelled in the air. Too much fuel in chamber. This can be caused by the carburetor needle sticking. Clogged Fuel Filter. 	<p>FUEL RELATED:</p> <ol style="list-style-type: none"> Fill fuel tank with fresh 87+ octane stabilizer-treated unleaded gasoline and open fuel valve. Do not use gasoline with more than 10% ethanol (E15, E20, E85, etc.). Move Choke to START position. Clean out ethanol rich gasoline from fuel system. Replace components damaged by ethanol. Use fresh 87+ octane stabilizer-treated unleaded gasoline only. Do not use gasoline with more than 10% ethanol (E15, E20, E85, etc.). Use fresh 87+ octane stabilizer-treated unleaded gasoline. Do not use gasoline with more than 10% ethanol (E15, E20, E85, etc.). Pull on Starter Handle to prime. Clean out passageways using fuel additive. Heavy deposits may require further cleaning. Gently tap side of carburetor float chamber with screwdriver handle. Turn Choke to RUN position. Remove spark plug and pull the Start Handle several times to air out the chamber. Reinstall spark plug and set Choke to START position. Replace Fuel Filter.
	<p>IGNITION (SPARK) RELATED:</p> <ol style="list-style-type: none"> Spark plug cap not connected securely. Spark plug electrode wet or dirty. Incorrect spark plug gap. Spark plug cap broken. Incorrect spark timing or faulty ignition system. 	<p>IGNITION (SPARK) RELATED:</p> <ol style="list-style-type: none"> Connect spark plug cap properly. Clean spark plug. Correct spark plug gap. Replace spark plug cap. Have qualified technician diagnose/repair ignition system.
	<p>COMPRESSION RELATED:</p> <ol style="list-style-type: none"> Cylinder not lubricated. Problem after long storage periods. Loose or broken spark plug. (Hissing noise will occur when trying to start.) Loose cylinder head or damaged head gasket. (Hissing noise will occur when trying to start.) Engine valves or tappets mis-adjusted or stuck. 	<p>COMPRESSION RELATED:</p> <ol style="list-style-type: none"> Pour tablespoon of oil into spark plug hole. Crank engine a few times and try to start again. Tighten spark plug. If that does not work, replace spark plug. If problem persists, may have head gasket problem, see #3. Tighten head. If that does not remedy problem, replace head gasket. Have qualified technician adjust/repair valves and tappets.



Follow all safety precautions whenever diagnosing or servicing the equipment or engine.

Problem	Possible Causes	Probable Solutions
Engine misfires	<ol style="list-style-type: none"> 1. Spark plug cap loose. 2. Incorrect spark plug gap or damaged spark plug. 3. Defective spark plug cap. 4. Old or low quality gasoline. 5. Incorrect compression. 	<ol style="list-style-type: none"> 1. Check wire connections. 2. Re-gap or replace spark plug. 3. Replace spark plug cap. 4. Use only fresh 87+ octane stabilizer-treated unleaded gasoline. Do not use gasoline with more than 10% ethanol (E15, E20, E85, etc.). 5. Diagnose and repair compression. (Use Engine will not start: COMPRESSION RELATED section.)
Engine stops suddenly	<ol style="list-style-type: none"> 1. Fuel tank empty or full of impure or low quality gasoline. 2. Low oil shutdown. 3. Defective fuel tank cap creating vacuum, preventing proper fuel flow. 4. Faulty magneto. 5. Disconnected or improperly connected spark plug cap. 	<ol style="list-style-type: none"> 1. Fill fuel tank with fresh 87+ octane stabilizer-treated unleaded gasoline. Do not use gasoline with more than 10% ethanol (E15, E20, E85, etc.). 2. Fill engine oil to proper level. Check engine oil before EVERY use. 3. Test/replace fuel tank cap. 4. Have qualified technician service magneto. 5. Secure spark plug cap.
Engine stops when under heavy load	<ol style="list-style-type: none"> 1. Dirty air filter 2. Engine running cold. 	<ol style="list-style-type: none"> 1. Clean or replace element. 2. Allow engine to warm up prior to operating equipment.
Engine knocks	<ol style="list-style-type: none"> 1. Old or low quality gasoline. 2. Engine overloaded. 3. Incorrect spark timing, deposit buildup, worn engine, or other mechanical problems. 	<ol style="list-style-type: none"> 1. Fill fuel tank with fresh 87+ octane stabilizer-treated unleaded gasoline. Do not use gasoline with more than 10% ethanol (E15, E20, E85, etc.). 2. Do not exceed equipment's load rating. 3. Have qualified technician diagnose and service engine.
Engine backfires	<ol style="list-style-type: none"> 1. Impure or low quality gasoline. 2. Engine too cold. 3. Intake valve stuck or overheated engine. 4. Incorrect timing. 	<ol style="list-style-type: none"> 1. Fill fuel tank with fresh 87+ octane stabilizer-treated unleaded gasoline. Do not use gasoline with more than 10% ethanol (E15, E20, E85, etc.). 2. Use cold weather fuel and oil additives to prevent backfiring. 3. Have qualified technician diagnose and service engine. 4. Check engine timing.



Follow all safety precautions whenever diagnosing or servicing the equipment or engine.

(c) Warranty Parts for Exhaust Emission.

- (1) Fuel System
- (2) Air Induction System
- (3) Ignition System

The following parts are also considered emission related components for exhaust emissions, if applicable

- (1) Exhaust Gas Recirculation (EGR) System
- (2) Aftertreatment devices.
- (3) Crankcase ventilation valves.
- (4) Sensors.
- (5) Electronic control units.

(d) Warranty Parts for Evaporative Emission include fuel tank, fuel cap, fuel line and fittings, carbon canister, vapor hoses. They may also include, if applicable, liquid/vapor separator, clamps, pressure relief valves, etc.

Du Du will furnish with each new engine/equipment written instructions for the maintenance and use of the engine/equipment by the owner.

PLEASE READ THE FOLLOWING CAREFULLY

THE MANUFACTURER AND/OR DISTRIBUTOR HAS PROVIDED THE PARTS LIST AND ASSEMBLY DIAGRAM IN THIS MANUAL AS A REFERENCE TOOL ONLY. NEITHER THE MANUFACTURER OR DISTRIBUTOR MAKES ANY REPRESENTATION OR WARRANTY OF ANY KIND TO THE BUYER THAT HE OR SHE IS QUALIFIED TO MAKE ANY REPAIRS TO THE PRODUCT, OR THAT HE OR SHE IS QUALIFIED TO REPLACE ANY PARTS OF THE PRODUCT. IN FACT, THE MANUFACTURER AND/OR DISTRIBUTOR EXPRESSLY STATES THAT ALL REPAIRS AND PARTS REPLACEMENTS SHOULD BE UNDERTAKEN BY CERTIFIED AND LICENSED TECHNICIANS, AND NOT BY THE BUYER. THE BUYER ASSUMES ALL RISK AND LIABILITY ARISING OUT OF HIS OR HER REPAIRS TO THE ORIGINAL PRODUCT OR REPLACEMENT PARTS THERETO, OR ARISING OUT OF HIS OR HER INSTALLATION OF REPLACEMENT PARTS THERETO.

BILT HARD

FIG.1 CRANKCASE. / GEAR ASSY, GOVERNOR. (E01)

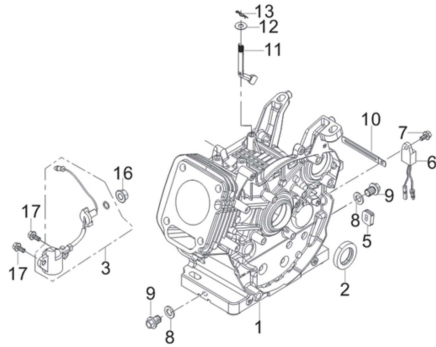

REF.NO.	PART NO	DESCRIPTION	Q'TY
E01-1	11310-Z730110-0BA0	CRANKCASE SUBASSEMBLY.	1
E01-2	90682-Z080110-00A0	SEAL, OIL	1
E01-3	37060-Z080120-0000	SENSOR, ENGINE OIL	1
E01-5	28101-Z080110-0000	PLUG, RUBBER	1
E01-6	37050-Z010210-0000	PROTECTOR, OIL	1
E01-7	90001-0612-01A0	BOLT	1
E01-8	90412-Z080110-00A0	FLAT WASHER	2
E01-9	11007-Z080110-00A0	BOLT, DRAIN PLUG	2
E01-10	90684-Z030120-0000	WIRE CLIP	1
E01-11	16061-Z080110-0000	ARM, GOVERNOR	1
E01-12	90412-Z080210-00A0	FLAT WASHER	1
E01-13	90501-Z010110-0000	COTTER PIN	1
E01-16	90305-Z010210-01A0	HEXAGON NUT WITH FLANGE	1
E01-17	90001-0616-01A0	BOLT	2

FIG.2 COVER SUBASSEMBLY, CRANKCASE (E02)

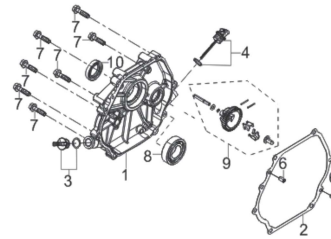

REF.NO.	PART NO	DESCRIPTION	Q'TY
E02-1	11411-Z580710-0BA0	COVER, CRANKCASE	1
E02-2	11001-Z580120-0000	GASKET, CRANKCASE	1
E02-3	15030-Z080130-Q500	PLUG SUBASSEMBLY, ENGINE OIL	1
E02-4	15010-Z080130-Q500	DIPSTICK SUBASSEMBLY, OIL	1
E02-6	90502-0912-00A0	POSITION PIN - TYPE A	2
E02-7	90001-0835-01A0	BOLT	7
E02-8	90547-0206-CLA0	DEEP GROOVE BALL BEARING	1
E02-9	16400-Z080110-00A0	GEAR ASSY, GOVERNOR	1
E02-10	90682-Z080110-00A0	SEAL, OIL	1

FIG.3 HEAD SUBASSEMBLY, CYLINDER / PLUG, SPARK (E03)

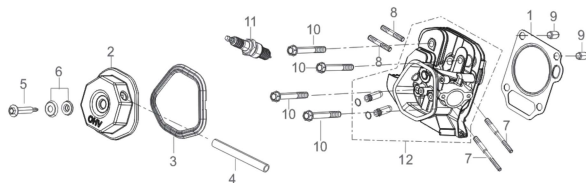

REF.NO.	PART NO	DESCRIPTION	Q'TY
E03-1	12131-Z730210-0000	GASKET, CYLINDER HEAD	1
E03-2	12410-Z580110-0199	COVER SUBASSEMBLY, CYLINDER HEAD	1
E03-3	12004-Z580110-0099	CYLINDER HEAD COVER GASKET	1
E03-4	17004-Z730110-00A0	TUBE, BREATHER	1
E03-5	12032-Z080110-01A0	CYLINDER HEAD COVER BOLT	1
E03-6	12034-Z080110-0099	GASKETS	1
E03-7	90204-Z080320-0000	STUD BOLT	2
E03-8	90204-Z100320-0000	STUD BOLT	2
E03-9	90502-1220-00A0	POSITION PIN - TYPE A	2
E03-10	12003-Z080110-00A0	CYLINDER HEAD BOLT	4
E03-11	30010-Z010210-00A0	PLUG, SPARK	1
E03-12	12140-Z730210-0BA9	HEAD SUBASSEMBLY, CYLINDER	1

FIG.4 ROD, CRANKSHAFT CONNETING (E04)

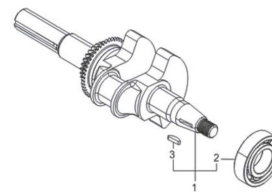

REF.NO.	PART NO	DESCRIPTION	Q'TY
E04-1	13300-Z730210-00A0	CRANKSHAFT ASSY.	1

FIG.5 RING SET,OIL / ROD,CRANKSHAFT CONNETING (E05)

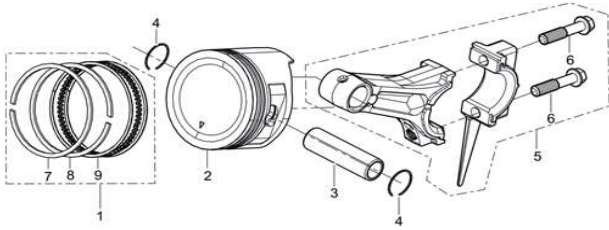

REF.NO.	PART NO	DESCRIPTION	Q'TY
E05-1	13200-Z730110-0099	RING ASSY, PISTON	1
E05-2	13111-Z730120-00A9	PISTON	1
E05-3	13121-Z730110-0000	PIN, PISTON	1
E05-4	13122-Z730110-00A9	CLIP, PISTON PIN	2
E05-5	13010-Z730120-00A9	ROD, CONNECTING	1

FIG.6 TRAIN,VALVE / CAMSHAFT SUBASSEMBLY E06)

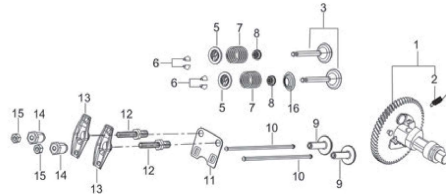

REF.NO.	PART NO	DESCRIPTION	Q'TY
E06-1	14200-Z730120-00A9	CAMSHAFT ASSY.	1
E06-3	12110-Z730110-00A9	VALVES SET	1
E06-5	12112-Z730110-00A0	SEAT, VALVE SPRING	2
E06-6	12109-Z730110-00A0	CLAMP, VALVE LOCK	4
E06-7	12103-Z730110-00A9	SPRING, VALVE	2
E06-8	12101-Z020110-00A0	GUIDE, SEAL	2
E06-9	14081-Z580110-00A0	TAPPET, VALVE	2
E06-10	14070-Z730110-00A0	LIFTER, VALVE	2
E06-11	14090-Z080110-00A0	PLATE SUBASSEMBLY, LIFTER STOPPER	1
E06-12	14313-Z010110-00A0	ROCKSHAFT BOLT	2
E06-13	14311-Z080110-00A0	ROCKER, VALVE	2
E06-14	14314-Z010110-00A0	NUT, VALVE ADJUSTING	2
E06-15	14312-Z010110-00A0	NUT, VALVE LOCK	2
E06-16	12105-Z080110-00A0	RETAINER, VALVE SPRING	1

FIG.7 STARTER,RECOIL (E07)

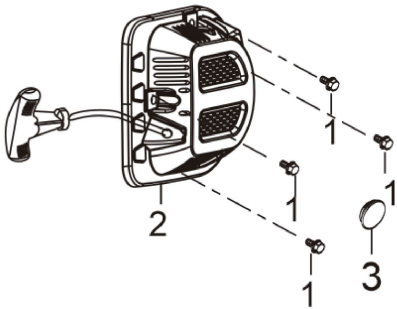

REF.NO.	PART NO	DESCRIPTION	Q'TY
E07-1	90001-0612-01A0	HEXAGON SOCKET FLANGE FACE BOLT - SMALL SERIES	4
E07-2	28200-Z080220-Q200	STARTER ASSY, RECOIL	1
E07-3	28102-Z010110-0000	CAP, RECOIL STARTER REEL END	1

FIG.8 SHROUD / SHIELD,LOWER (E08)

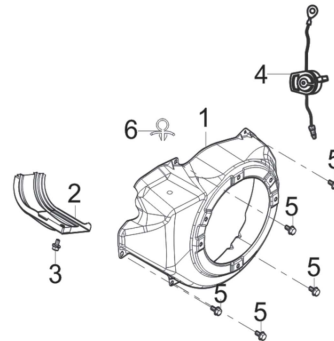

REF.NO.	PART NO	DESCRIPTION	Q'TY
E14-1	28110-Z080410-BK00	SHROUD	1
E14-2	19304-Z080110-0000	SHROUD, CYLINDER BODY	1
E14-3	90001-0612-01A0	BOLT	1
E14-4	35540-Z060140-QG00	SWITCH SUBASSEMBLY, STOP ENGINE	1
E14-5	90001-0612-01A0	BOLT	5
E14-6	90684-Z080110-0000	WIRE CLIP	1

FIG.9 CARBURETOR ASSY. (E09)

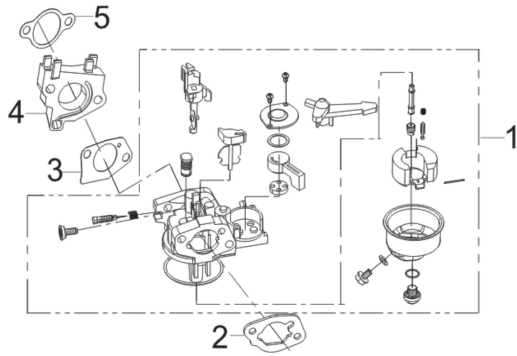

REF.NO.	PART NO	DESCRIPTION	Q'TY
E09-1	16100-Z730310-00A9	CARBURETOR ASSY.	1
E09-2	17001-Z080210-0000	AIR CLEANER SEAL GASKET	1
E09-3	16001-Z080110-0000	CARBURETOR SEAL GASKET	1
E09-4	16003-Z730110-0000	PLATE, CARBURETOR INSULATOR	1
E09-5	17002-Z080110-0000	GASKET, INLET	1

FIG.10 FLYWHEEL / IMPELLER / STARTER PULLEY / IGNITION COIL (E10)

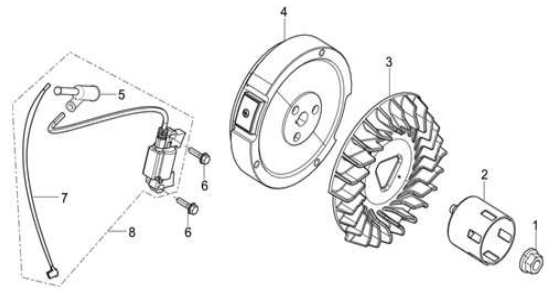

REF.NO.	PART NO	DESCRIPTION	Q'TY
E10-1	13501-Z080110-00A0	NUT, FLYWHEEL	1
E10-2	28002-Z080310-0000	PULLEY,STARTER	1
E10-3	19352-Z080110-00A0	IMPELLER	1
E10-4	13510-Z080110-00A0	FLYWHEEL SUBASSEMBLY	1
E10-6	90001-0628-01A0	HEXAGON SOCKET FLANGE FACE BOLT - SMALL SERIES	2
E10-8	30400-Z080310-0100	COIL, IGNITION	1

FIG.11 CONTROL ASSY, THROTTLE (E11)

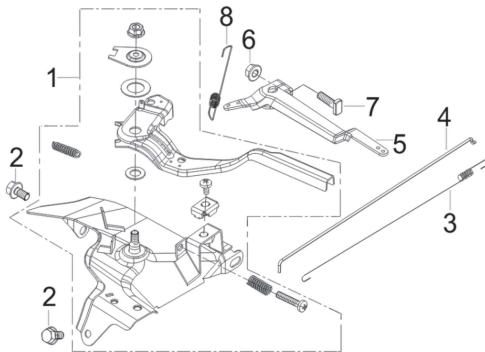

REF.NO.	PART NO	DESCRIPTION	Q'TY
E11-1	16520-Z080430-00A0	CONTROL ASSY, THROTTLE	1
E11-2	90001-0612-01A0	BOLT	2
E11-3	16012-Z080110-0000	SPRING, THROTTLE VALVE RETURNING	1
E11-4	16062-Z080110-0000	ROD, GOVERNEOR	1
E11-5	16070-Z080110-0000	GOVERNOR BRACKET SUBASSEMBLY	1
E11-6	90305-0600-31A0	HEXAGON NUT WITH FLANGE	1
E11-7	16072-Z010110-00A0	BOLT, GOVERNOR SUPPORT	1
E11-8	16063-Z080310-0000	SPRING, GOVERNOR	1

FIG.12 CLEANER, AIR (F01)

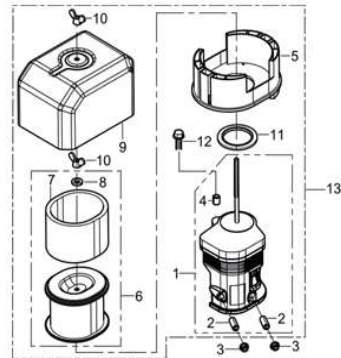

REF.NO.	PART NO	DESCRIPTION	Q'TY
F01-3	90305-0600-31A0	HEXAGON NUT WITH FLANGE	2
F01-12	90007-0620-A1A0	BOLT	1
F01-13	17100-Z080610-0000	AIR CLEANER	1

FIG.13 MUFFLER ASSY. (F02)

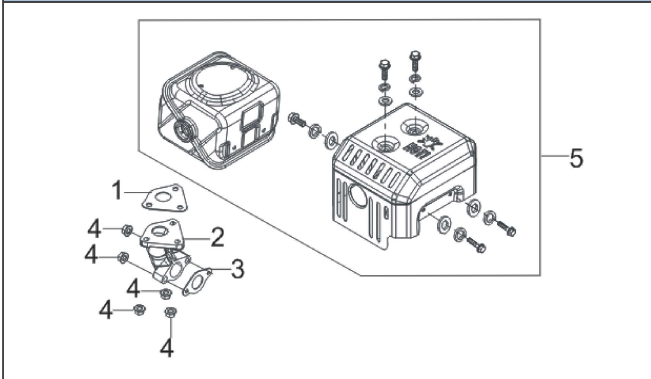

REF.NO.	PART NO	DESCRIPTION	Q'TY
F02-1	18101-Z080110-0000	GASKET, MUFFLER	1
F02-2	18150-Z080210-00A0	PIPE, EXHAUST	1
F02-3	18001-Z080110-00A0	GASKET, EXHAUST OUTLET	1
F02-4	90305-0800-31A0	HEXAGON NUT WITH FLANGE	5
F02-5	18100-Z080110-00A0	MUFFLER ASSY.	1

FIG.14 TANK ASSY, FUEL (F03)

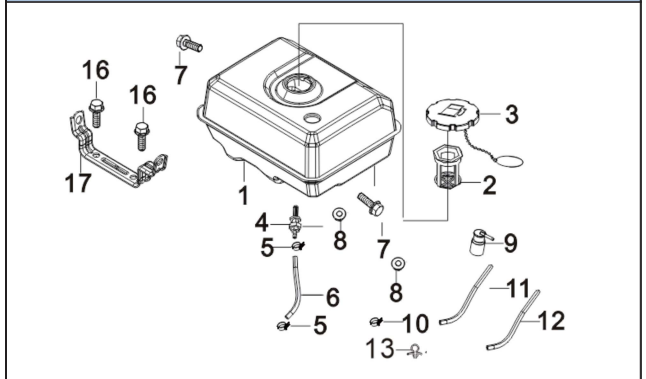

REF.NO.	PART NO	DESCRIPTION	Q'TY
F03-1	16620-Z080910-A0	FUEL TANK	1
F03-2	16652-Z010710-00A0	STRAINER, FUEL	1
F03-3	16730-Z010430-0000	COVER, FUEL TANK	1
F03-4	16680-Z010110-0000	OUTLET SUBASSEMBLY, FUEL TANK OIL	1
F03-5	90685-D080-0EA0	PIPE CLAMP	2
F03-6	90686-Z080510-00M0	TUBE, FUEL	1
F03-7	90001-0820-01A0	HEXAGON SOCKET FLANGE FACE BOLT - SMALL SERIES	2
F03-8	90305-0800-31A0	HEXAGON NUT WITH FLANGE	2
F03-9	15150-Z010510-0000	VALVE, ONE WAY	1
F03-10	90685-D090-0EA0	PIPE CLAMP	1
F03-11	16805-Z310110-0000	HOSE, AIR CLEANER RUBBER	1
F03-12	16807-Z310110-0000	FUEL STEAM RUBBER HOSE BUSH	1
F03-13	90684-Z080110-0000	WIRE CLIP	1
F03-16	90001-0816-01A0	HEXAGON SOCKET FLANGE FACE BOLT - SMALL SERIES	2
F03-17	16612-Z080120-H700	FRAME, FUEL TANK INSTALLTION	1

Mounting Hole Diagram

Note: Not to scale.

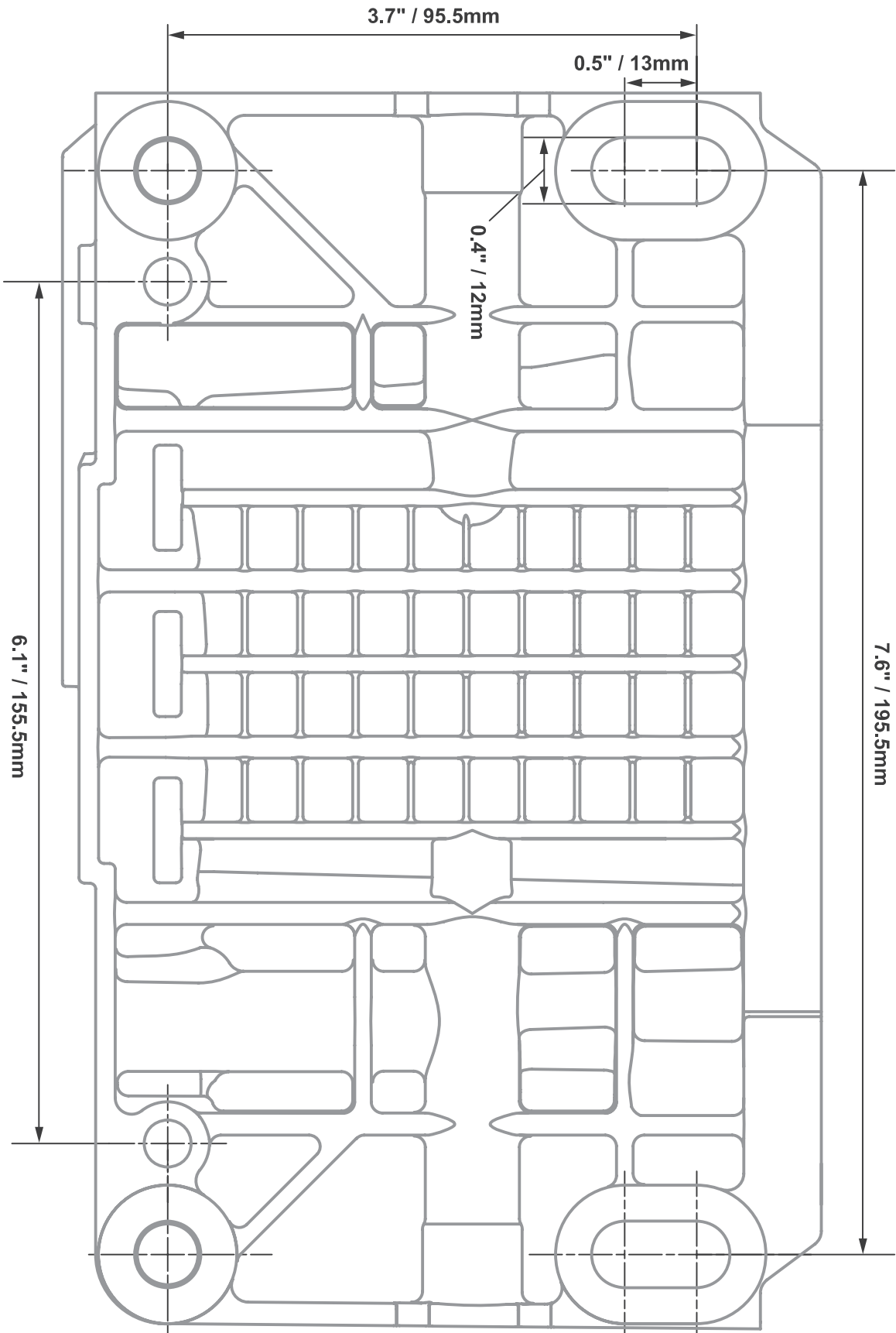

Power Take-Off Diagram

Note: Not to scale.

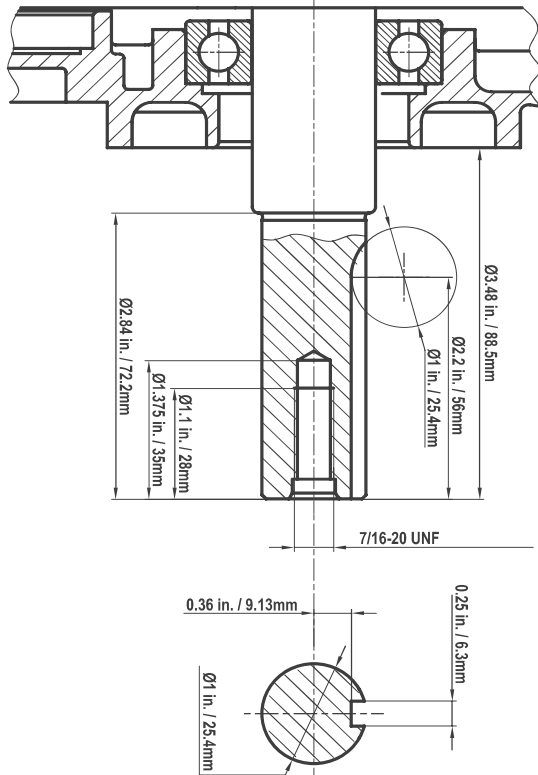
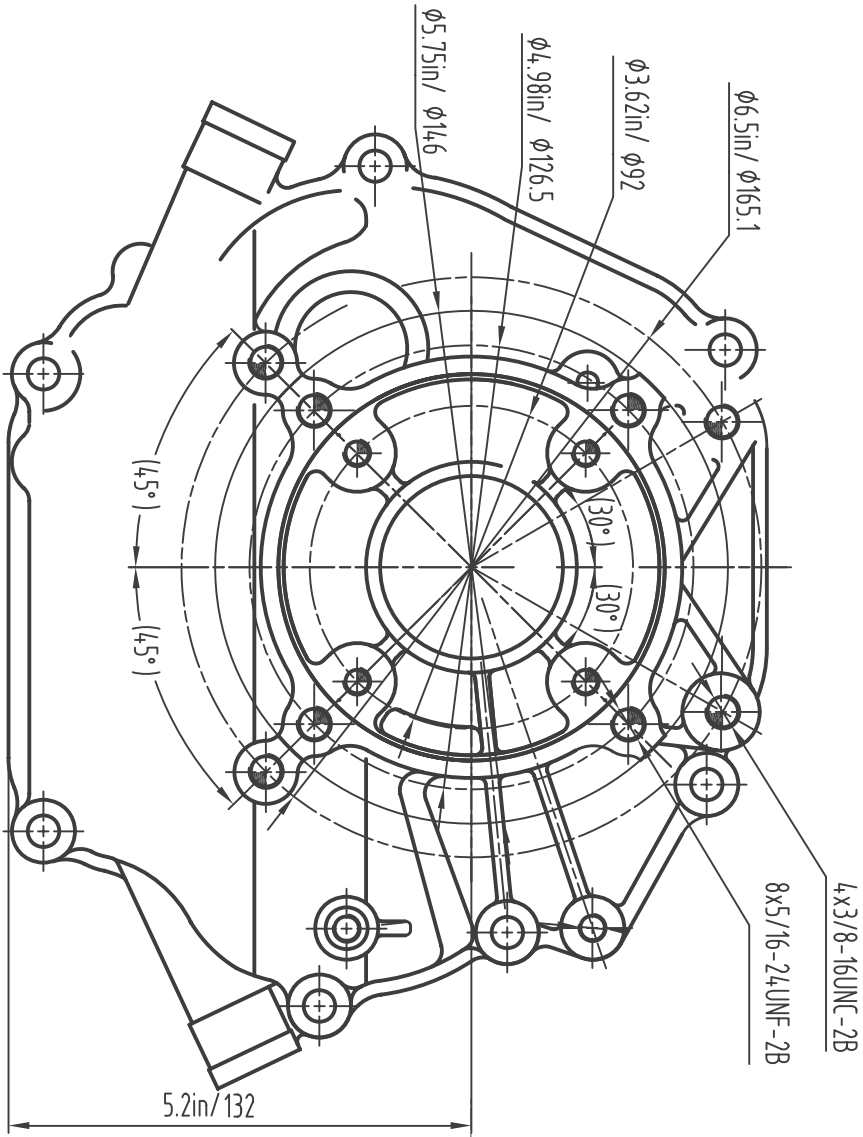

BILT HARD