

BILT HARD

CHAINSAW 18 inch

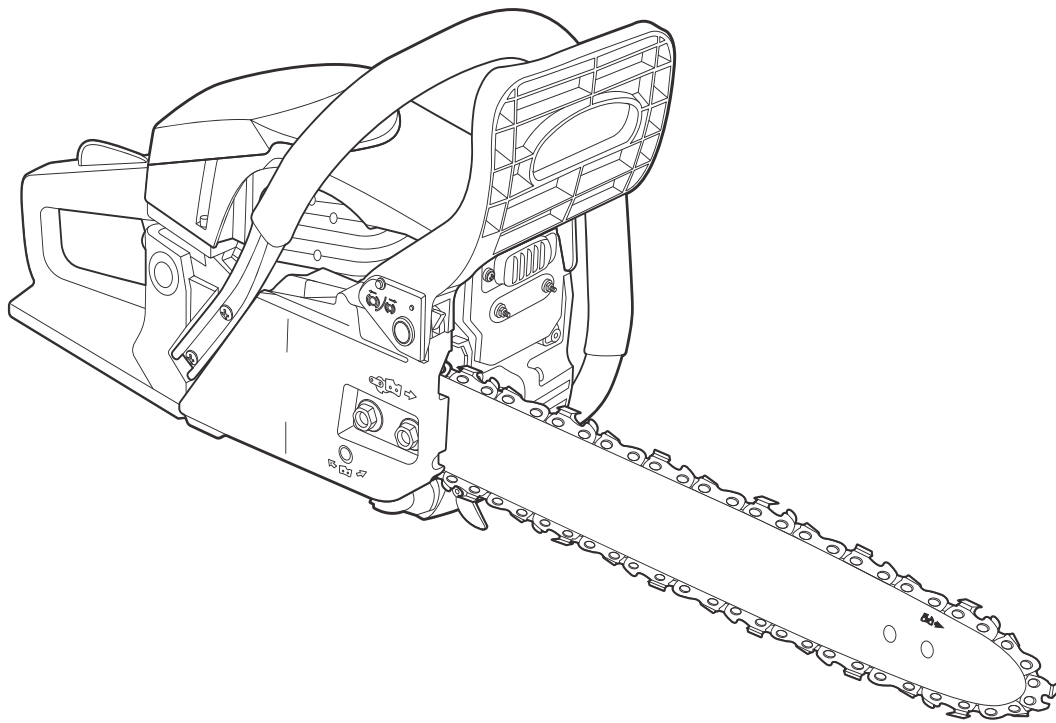

TNA-0005

Thank you for ordering our product.
If you have any issue,
please email it and your order ID to
inquiry@bilthardusa.com or call (888)680-2849

Using tips:
Video on Youtube



WARNING: Read the instructions before using the product!

TABLE OF CONTENTS

Service2
Safety2
Know Your Unit7
Essential Terms and Definitions8
Specifications9
Assembly10
Oil and Fuel11
Starting and Stopping12
Operation13
Maintenance19
Cleaning and Storage27
Troubleshooting28
Warranty29

All information, illustrations, and specifications in this manual are based on the latest product information available at the time of printing. We reserve the right to make changes at any time without notice.

The product may vary slightly from the illustrations contained in this manual.

NOTE: This operator's manual covers multiple models. Features may vary by model. Not all features in this manual are applicable to all models. The model depicted may differ from yours.

SERVICE

DO NOT RETURN THIS UNIT TO THE RETAILER. PROOF OF PURCHASE WILL BE REQUIRED FOR WARRANTY SERVICE.

For assistance regarding the assembly, operation or maintenance of the unit, please call (888)680-2849 .

SAFETY

The purpose of safety symbols is to attract your attention to possible dangers. The safety symbols, and their explanations, deserve your careful attention and understanding. The safety warnings do not by themselves eliminate any danger. The instructions or warnings they give are not substitutes for proper accident prevention measures.

SYMBOL	MEANING
--------	---------



DANGER: Signals an EXTREME hazard.
Failure to obey a safety **DANGER** symbol **WILL** result in serious injury or death to yourself or to others.



WARNING: Signals a SERIOUS hazard.
Failure to obey a safety **WARNING** symbol **CAN** result in serious injury to yourself or to others.



CAUTION: Signals a MODERATE hazard.
Failure to obey a safety **CAUTION** symbol **MAY** result in property damage or injury to yourself or to others.

NOTE: Advises you of information or instructions vital to the operation or maintenance of the equipment.

• IMPORTANT SAFETY INSTRUCTIONS •

READ ALL INSTRUCTIONS BEFORE OPERATING



WARNING: When using the unit, all safety instructions must be followed. Please read these instructions before operating the unit in order to ensure the safety of the operator and any bystanders. Please keep these instructions for later use.

- Read the instructions carefully. Be familiar with the controls and proper use of the unit. Know how to stop the unit and disengage the controls quickly.
- Stay alert. Do not operate this unit when tired, ill or under the influence of alcohol, drugs or medication.
- Never allow children to operate the unit. Never allow adults to operate the unit without proper instruction.
- All guards and safety attachments must be installed properly before operating the unit.
- Inspect the unit before use. Check for damaged parts. Check for fuel leaks. Make sure all parts operate properly. Make sure all fasteners are in place and secure. Make sure all moving parts are properly aligned and are not bound. Replace parts that are cracked, chipped, or damaged in any way. Have all damaged or improperly working parts repaired or replaced by an authorized service center. Do not operate the unit with loose or damaged parts.
- Be aware of risk of injury to the head, hands and feet.
- Carefully inspect the area before starting the unit. Remove rocks, broken glass, nails, wire, string and other objects that may be thrown or become entangled with the unit.
- Clear the area of children, bystanders and pets; keep them outside a 50-foot (15 m) radius, at a minimum. Even then, they are still at risk from thrown objects. Encourage bystanders to wear eye protection. If you are approached, stop the unit immediately.
- Squeeze the throttle control and check that it returns automatically to the idle position. Make all adjustments or repairs before using the unit.
- This unit is intended for occasional, household use only.

SAFETY WARNINGS FOR GAS UNITS



WARNING: Use caution when handling fuel. Gasoline is highly flammable and its vapors can explode if ignited. Take the following precautions:

- Store fuel only in containers specifically designed and approved for the storage of such materials.
- Always stop the engine and allow it to cool before filling the tank. Never remove the fuel tank cap or add fuel when the engine is hot. Always loosen the fuel tank cap slowly to relieve any pressure in the tank before fueling.
- Always mix and add fuel in a clean, well-ventilated outdoor area where there are no sparks or flames. DO NOT smoke.
- Never operate the unit without the fuel cap securely in place.
- Avoid creating a source of ignition for spilled fuel. Wipe up any spilled fuel from the unit immediately, before starting the unit. Move the unit at least 30 ft. (9.1 m) from the fueling source and site before starting the engine. DO NOT smoke.
- Never start or run the unit inside a closed room or building. Breathing exhaust fumes can kill. Operate this unit only in a well-ventilated outdoor area.

WHILE OPERATING

- Wear safety glasses or goggles that meet current ANSI / ISEA Z87.1 standards and are marked as such. Wear ear/hearing protection when operating this unit. Wear a face mask or dust mask if the operation is dusty. Use a hard hat or other type of safety helmet.
- Wear safety boots and protective gloves. Wear heavy, snug-fitting clothes, including long pants and a long-sleeve shirt. Do not wear loose clothing, jewelry, short pants, sandals or go barefoot. Secure hair above shoulder level.
- Make sure the saw chain is not in contact with anything before starting the unit.
- Use the unit only in daylight or good artificial light.
- Avoid accidental starting. Be in the starting position whenever pulling the starter rope. The operator and unit must be in a stable position while starting. Refer to *Starting and Stopping*.
- Use the right tool. Only use this tool for its intended purpose: to cut wood. Do not use the unit for cutting plastic, masonry or other non-wood building materials. Only use the unit as described in this manual.
- Keep hair, face, hands, feet and all other body parts away from the saw chain when the unit is running. Do not touch or try to stop moving parts.
- Do not touch the engine or muffler. These parts get extremely hot from operation, even after the unit is turned off.
- Do not operate the unit faster than the speed needed to do the job. Do not run the unit at high speed when not in use.
- Do not force the unit, especially near the end of a cut. It will do a better, safer job when used at the intended rate.
- Always turn the unit off when operation is delayed or when carrying the unit from one location to another. Make sure all moving parts come to a complete stop.
- Before setting the unit down, always make sure the engine is off and all moving parts have stopped.
- Turn the engine off and disconnect the spark plug for maintenance or repair.
- Carry the unit by the front handle with the muffler positioned away from the body and the guide bar positioned to the rear. Cover the guide bar and saw chain with the scabbard when carrying the unit.
- If the unit strikes or becomes entangled with a foreign object, stop the unit immediately. Check for damage. If damaged, do not restart or operate the unit until it is repaired. Do not operate the unit with loose or damaged parts.
- Use only original equipment manufacturer (OEM) replacement parts and accessories for this unit. These are available from your authorized service dealer. Use of any other parts or accessories could lead to serious injury to the user, or damage to the unit, and void the warranty.
- Keep the unit clean. Carefully remove vegetation and other debris that could block moving parts.
- To reduce fire hazard, replace a faulty muffler and spark arrestor. Keep the engine and muffler free from grass, leaves, excessive grease or carbon build up.
- If the unit starts to vibrate abnormally, stop the unit immediately. Inspect the unit for the cause of the vibration. Vibration is generally an indicator of trouble.
- Keep the work area clean. Cluttered areas invite injuries. Do not start cutting until the work area is clear and free from obstructions. Make sure there is secure footing and a planned retreat path from falling trees or branches.
- Do not cut near electrical cables or power lines. Keep at least 50 feet (15 m) away from all power lines.

- For safer, more effective performance, make sure the guide bar and chain are properly cleaned, lubricated, tightened and sharpened. Check the guide bar and chain at frequent intervals for proper adjustment.
- When cutting a limb that is under tension, the limb could spring back and strike the operator, causing severe injury or death.
- Use extreme caution when cutting small-sized brush and saplings, as slender material may catch the saw chain and be whipped toward the operator or pull the operator off balance.
- This saw is classified by UL as a Class 1C saw in accordance with CSA Z62.1-03. It is intended for infrequent use by homeowners, cottagers and campers, and for general applications such as clearing, pruning, cutting firewood, etc. It is not intended for prolonged use. If the intended use involves prolonged periods of operation, this may cause circulatory problems in the user's hands due to vibration.
- Never remove, modify or make inoperative any safety device furnished with the unit.
- Do not use the unit in the presence of flammable liquids or gases.
- Do not attempt operations beyond the operator's capacity or experience.
- Do not operate a unit that is damaged, improperly adjusted or not completely and securely assembled. Make sure moving parts stop when the unit is turned off. Do not use the unit if it does not turn on and off properly. Have defective parts replaced by an authorized service dealer.

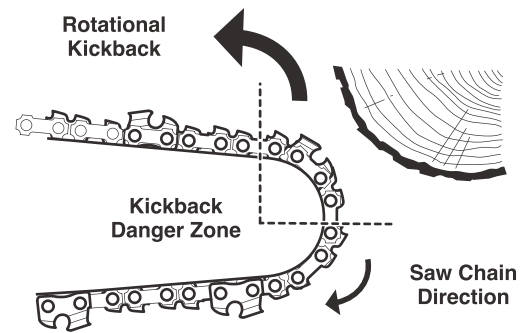

Fig. A

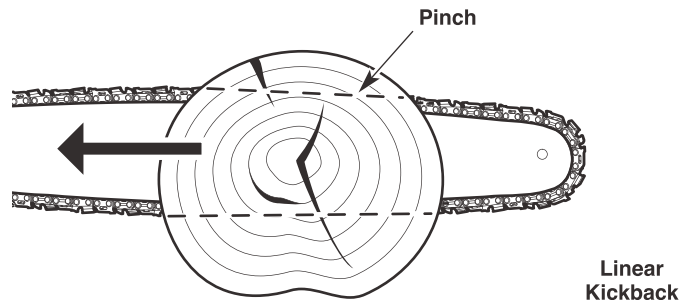

Fig. B

KICKBACK SAFETY

	<p>WARNING: Kickback may occur when the nose or tip of the guide bar touches an object, or when the wood closes in and pinches the saw chain in the cut. In some cases, tip contact may cause a lightning-fast reverse action, kicking the guide bar rapidly back towards the operator. Pinching the saw chain along the top of the guide bar may push the guide bar rapidly back towards the operator. Either of these reactions may cause a loss of control over the saw, which could result in serious injury to the user. Contact with foreign objects within the wood can also induce a loss of chain saw control.</p>
--	--

Understanding Kickback

A basic understanding of kickback can help reduce or eliminate the element of surprise and the chance of kickback-related injury. Sudden surprise contributes to accidents.

- **Rotational Kickback** can happen when the upper tip of the guide bar contacts an object while the chain is moving (Fig. A). This can cause the chain to dig into the object and momentarily stop moving. The guide bar is then kicked up and back toward the operator in a lightning-fast reverse reaction.
- **Linear Kickback** can happen when the wood on either side of a cut closes in and pinches the moving saw chain along the top of the guide bar (Fig. B). This can cause the chain to instantly stop. The chain force is then reversed, causing the saw to move in the opposite direction, sending the saw straight back toward the operator.
- **Pull-In** can happen when the moving chain on the bottom of the guide bar hits a foreign object inside the wood. This can cause the chain to suddenly stop. The saw is then pulled forward and away from the operator, which could potentially result in the loss of control of the saw.

Kickback Safety Precautions

Take the following steps to reduce the chance of accident or injury:

- Do not rely exclusively upon the safety devices built into the unit.
- Do not cut above shoulder height.
- Do not overreach. Always keep proper footing and balance. Take extra care when working on steep slopes or inclines. Do not operate the unit in a tree or on a ladder unless specifically trained to do so.
- Do not make cuts with the tip of the guide bar.
- Make sure the area of operation is free from obstructions. Do not let the tip of the guide bar contact any object, such as a log, branch, the ground or other obstruction.
- Always inspect the wood before cutting. Foreign objects could damage the unit or cause serious personal injury. Never cut through nails, metal rods, railroad ties or pallets.
- Do not operate the unit with one hand! Serious injury to the operator, helpers or bystanders may result from one-handed operation. This unit is intended for two-handed use. Always grip the unit firmly with both hands when the unit is running. Hold the front handle with the left hand and the rear handle with the right hand. Firmly encircle the handles with the thumbs and fingers. Do not let go. A firm grip will help maintain control of the unit and reduce the chance of kickback.
- Stand slightly to the left of the unit to avoid being in the direct line of the saw chain.
- Never start the saw when the guide bar is inside an existing cut. Be extremely careful when re-entering a cut.
- Always begin a cut with the unit running at full speed. Fully squeeze the throttle control and maintain a steady cutting speed. Slower speeds increase the chance of kickback.
- Keep the saw housing pressed firmly against the wood.
- Do not cut more than one log or branch at a time.

- Do not twist the unit when removing the guide bar from a cut.
- Watch out for shifting objects (logs, branches, etc.) that might pinch or fall onto the saw chain during operation.
- Only use wedges made of wood or plastic. Do not use metal to hold a cut open.
- Follow the manufacturer's sharpening and maintenance instructions for the saw chain.
- Only use replacement bars and chains specified by the manufacturer or the equivalent. These are available from authorized service dealers. Use of any unauthorized parts or accessories could lead to serious injury to the operator or damage to the unit and will void the warranty.
- Use devices that reduce the risks associated with kickback, such as low-kickback chains, guide bar nose guards, chain brakes and low-kickback guide bars. There are no other replacement components for achieving kickback protection in accordance with CSA Z62.3.
- A low-kickback saw chain is a chain that has met the kickback performance requirements of ANSI/OPEI B175.1-2012 when tested according to the provisions specified in ANSI/OPEI B175.1-2012. A low-kickback saw chain is a chain that is also in accordance with CSA Z62.3. Do not use a replacement saw chain unless it has met these requirements for this specific model or has been designated as a low-kickback replacement saw chain in accordance with ANSI/OPEI B175.1-2012. As saw chains are sharpened, some of the low-kickback qualities are lost and extra caution should be used.
- Do not install a bow guide on this unit. Bow guides have larger kickback zones, which increase the chance of kickback and serious injury. This increase is not significantly reduced by using a low-kickback saw chain. Using a bow guide on this unit is extremely dangerous.





OTHER SAFETY WARNINGS











- Maintain the unit with care. Follow all maintenance instructions in this manual.
- Do not perform maintenance procedures other than those described in this manual. All service, other than the maintenance procedures described in this manual, should be performed by an authorized service dealer.
- Do not use the unit if it is not working correctly, has been dropped, damaged, left outdoors or dropped into water. Have the unit serviced by an authorized service dealer.
- Never remove, modify or make inoperative any safety device furnished with the unit.
- Before inspecting, maintaining, cleaning, storing, transporting or replacing any parts on the unit:
 1. Stop the unit. Refer to *Starting and Stopping*.
 2. Make sure all moving parts have stopped.
 3. Allow the unit to cool.
 4. Disconnect the spark plug wire.
- Secure the unit while transporting.
- Always use the scabbard on the guide bar and saw chain during transportation and storage.
- Always store the unit and fuel in a cool, dry and well-ventilated space. Do not store fuel, or a unit with fuel in the tank, indoors where fumes may reach open flames (pilot lights, etc.) or sparks (switches, electrical motors, etc.).
- Store the unit in a dry place, secured or at a height to prevent unauthorized use or damage. Keep the unit out of the reach of children.
- Never douse or squirt the unit with water or any other liquid. Keep handles dry, clean and free from debris, oil, fuel and grease. Clean the unit after each use. Refer to *Cleaning and Storage*. Do not use solvents or strong detergents.
- Keep these instructions. Refer to them often and use them to instruct other users. If you loan this unit to others, also loan them these instructions.

SAVE THESE INSTRUCTIONS

• SAFETY & INTERNATIONAL SYMBOLS •

This operator's manual describes safety and international symbols and pictographs that may appear on this product. Read the operator's manual for complete safety, assembly, operating and maintenance and repair information.

SYMBOL	MEANING
	<ul style="list-style-type: none"> • SAFETY ALERT SYMBOL Indicates danger, warning or caution. May be used in conjunction with other symbols or pictographs.
	<ul style="list-style-type: none"> • READ OPERATOR'S MANUAL WARNING: Read the operator's manual(s) and follow all warnings and safety instructions. Failure to do so can result in serious injury to the operator and/or bystanders.
	<ul style="list-style-type: none"> • WEAR HEAD, EYE AND HEARING PROTECTION WARNING: Thrown objects and loud noise can cause severe eye injury and hearing loss. Wear eye protection meeting current ANSI Z87.1 standards and ear protection when operating this unit. Wear head protection when operating this unit; falling objects can cause severe head injury. Use a full face shield when needed.
	<ul style="list-style-type: none"> • UNLEADED FUEL Always use clean, fresh unleaded fuel. • OIL Refer to operator's manual for the proper type of oil.
	<ul style="list-style-type: none"> • DO NOT USE E85 FUEL IN THIS UNIT WARNING: It has been proven that fuel containing greater than 10% ethanol will likely damage this engine and void the warranty.

SYMBOL	MEANING
	<ul style="list-style-type: none"> • ON/OFF STOP CONTROL ON / START / RUN
	<ul style="list-style-type: none"> • ON/OFF STOP CONTROL OFF or STOP
	<ul style="list-style-type: none"> • PRIMER BULB Push primer bulb, fully and slowly, 10 times.
	<ul style="list-style-type: none"> • CHOKE CONTROL <ul style="list-style-type: none"> • Pulled Out - FULL choke position • Pushed In - RUN position
 Min. 50 ft (15m)	<ul style="list-style-type: none"> • KEEP BYSTANDERS AWAY WARNING: Keep all bystanders, especially children and pets, at least 50 feet (15 m) from the operating area.
	<ul style="list-style-type: none"> • USE BOTH HANDS WARNING: Always use both hands while operating the unit. Never use only one hand to operate the unit.
	<ul style="list-style-type: none"> • KICKBACK WARNING: Contact of the guide bar tip with any object should be avoided. Tip contact may cause the guide bar to move suddenly upward and backward, which may cause serious injury.
	<ul style="list-style-type: none"> • CHAIN OIL ADJUSTMENT INDICATOR The chain must be continuously coated with oil to function properly. Make sure to set the oil adjustment screw to allow a sufficient amount of oil to flow continuously onto the chain.
	<ul style="list-style-type: none"> • CHAIN BRAKE The chain brake immediately stops the moving saw chain in emergency situations. To manually engage the chain brake, push the chain brake lever forward completely. To disengage the chain brake, pull the chain brake lever back completely.
	<ul style="list-style-type: none"> • CHAIN DIRECTION Make sure the saw chain faces the direction shown when installed on the guide bar. Refer to <i>Installing the Guide Bar and Saw Chain</i> in the <i>Maintenance</i> section.
	<ul style="list-style-type: none"> • CHAIN TENSIONING Always keep the saw chain properly tensioned. Turn the chain-tensioning screw clockwise to tighten the saw chain. Turn the chain-tensioning screw counterclockwise to loosen the saw chain.

KNOW YOUR UNIT

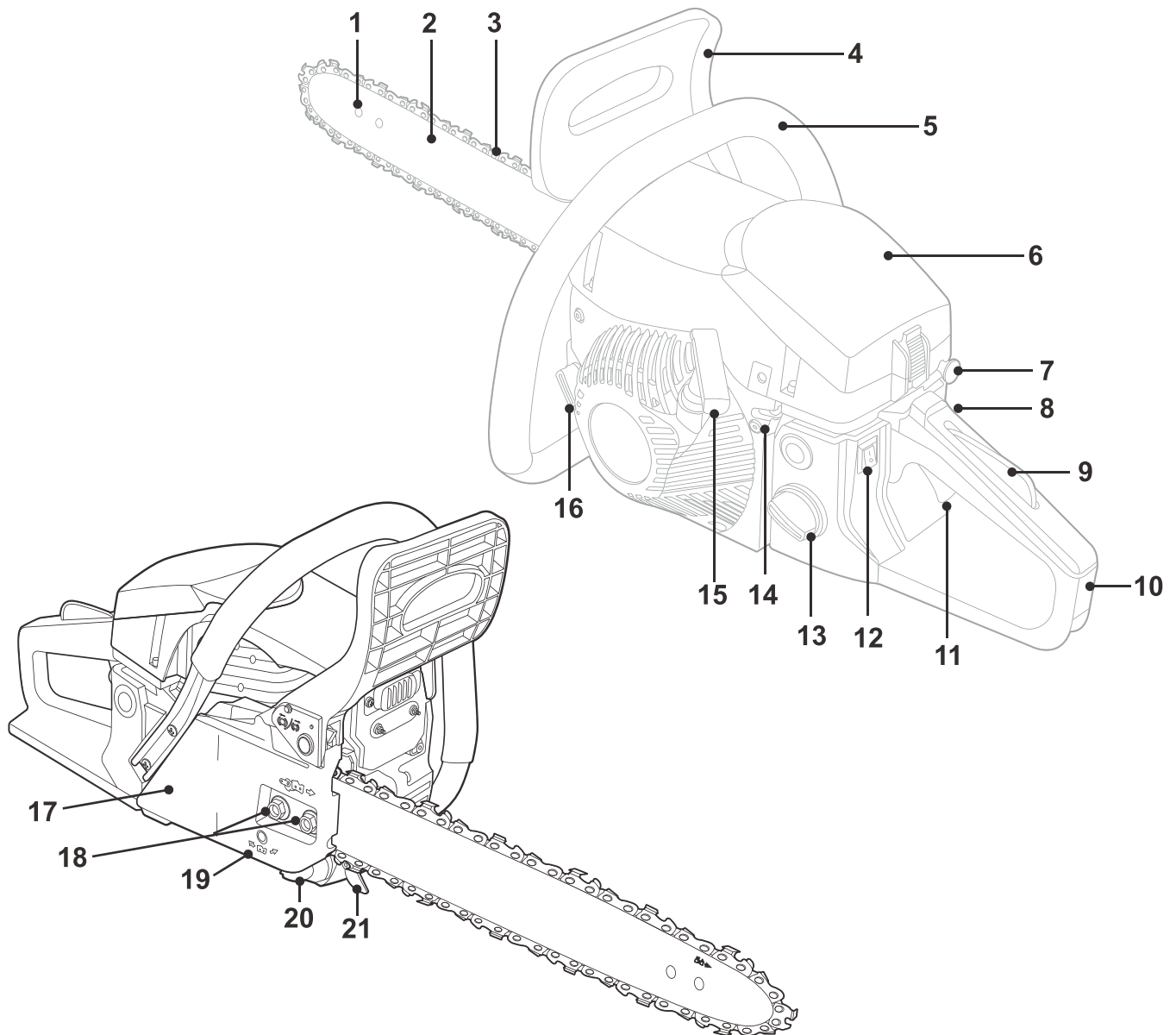

- | | |
|--|-------------------------------------|
| 1. Lubrication holes (on both sides) | 12. Stop switch |
| 2. Guide bar | 13. Fuel tank cap |
| 3. Saw chain | 14. Adjusting screws for carburetor |
| 4. Front hand guard (with chain brake) | 15. Recoil starter handle |
| 5. Front handle (for left hand) | 16. Oil tank cap |
| 6. Back cover | 17. Clutch cover |
| 7. Choke knob | 18. Fixing nuts |
| 8. Primer | 19. Chain tension adjuster |
| 9. Throttle trigger lock-out | 20. Chain catcher |
| 10. Rear handle (for right hand) | 21. Spiked bumper |
| 11. Throttle trigger | |

ESSENTIAL TERMS AND DEFINITIONS

- CHAIN SAW - A tool designed to cut wood with a saw chain. A chain saw is an integrated unit comprised of a power source, saw chain, guide bar, and handles that are designed to be held by two hands during operation.
- CHAIN SAW POWERHEAD - A chain saw without the saw chain and guide bar.
- DRIVE SPROCKET - A toothed wheel that drives the saw chain.
- FRONT HANDLE - A support handle located toward the front of the chain saw.
- REAR HANDLE - A support handle located toward the rear of the chain saw.
- CHAIN BRAKE LEVER / FRONT HAND GUARD - A structural barrier between the front handle and the guide bar. The front hand guard helps protect the operator's left hand if it slips off the front handle while the unit is running. The chain brake lever is also used to manually engage the chain brake.
- CHAIN BRAKE - A device that reduces the chance of injury if kickback occurs, by stopping the saw chain in milliseconds. The chain brake is designed to engage automatically in response to kickback. The chain brake can also be activated by pushing the chain brake lever forward, either intentionally or if the operator's hand strikes the lever during kickback.
- REAR HAND GUARD - A structural barrier below the rear handle. The rear hand guard helps protect the operator's right hand if the saw chain breaks or disengages from the guide bar during operation.
- GUIDE BAR - A solid railed structure that supports and guides the saw chain.
- GUIDE BAR TIP - The tip or end of the guide bar.
- REDUCED-KICKBACK GUIDE BAR - A guide bar that has been demonstrated to reduce kickback significantly.
- SAW CHAIN - A loop of chain with teeth designed to cut wood, which is driven by the engine and is supported by the guide bar. The saw chain is composed of drive links, cutters and side links, held together by rivets.
- LOW-KICKBACK SAW CHAIN - A saw chain that complies with the kickback performance requirements of ANSI/OPEI B175.1-2012 when tested on a representative sample of chain saws. Low-kickback saw chain significantly reduces the chance of kickback and the intensity of kickback, due to specially designed depth gauges and guard links.
- REPLACEMENT SAW CHAIN - A saw chain that complies with the kickback performance requirements of ANSI/OPEI B175.1-2012 when tested with specific chain saws. It may not meet the ANSI/OPEI performance standards when used with other chain saws.
- SPIKED BUMPER - The pointed tooth (or teeth), at the front of the chain saw, used during felling and bucking to help pivot the saw and maintain a stable position while cutting.
- CHAIN CATCHER - A device designed to intercept a whipping chain. The chain catcher reduces the chance of injury if the saw chain breaks or disengages from the guide bar during operation.
- OILER CONTROL - A system for oiling the saw chain and guide bar.
- ON/OFF SWITCH - A device that immediately stops the engine when moved to the OFF position. The saw chain will then coast to a stop. The On/Off switch must be moved to the On position to start the engine.
- THROTTLE CONTROL - A device used in conjunction with the throttle lockout to accelerate the engine. Releasing the throttle control returns the engine to idle.
- THROTTLE LOCKOUT - A device that prevents accidental acceleration of the engine. The throttle control cannot be squeezed unless the throttle lockout is engaged.
- SPARK ARRESTER SCREEN - A device that retains carbon and other flammable particles over 0.023 inches (0.6mm) in size from the engine exhaust flow. Compliance with local, state and federal laws and/or regulations governing the use of a spark arrester screen is the user's responsibility. Refer to *Spark Arrester Note* in the *Safety* section for additional information.
- KICKBACK - A sudden backward and/or upward motion of the guide bar and saw chain. Kickback can occur if the upper portion of the guide bar tip touches an object while the saw chain is spinning (rotational kickback). Kickback can also occur if the wood closes in and pinches the saw chain inside the cut (linear kickback).
- ROTATIONAL KICKBACK - A sudden backward and upward motion of the guide bar and saw chain. Rotational kickback can occur if the upper portion of the guide bar tip touches an object while the saw chain is spinning. The guide bar and saw chain are then kicked up and back toward the operator in a lightning-fast reverse reaction.
- LINEAR KICKBACK (PINCH KICKBACK) - A sudden backward motion of the guide bar and saw chain. Linear (pinch) kickback can occur if the wood closes in and pinches the saw chain inside a cut. The saw is then sent straight back toward the operator.
- NORMAL CUTTING POSITION - The positions assumed while making bucking and felling cuts.
- FELLING - The process of cutting down a tree.
- NOTCHED UNDERCUT - The first cutting procedure in the tree felling process. A notch is cut on one side of the tree to direct its fall.
- FELLING BACK CUT - The final cut in the tree felling process. The felling back cut is made on the opposite side of the tree from the notched undercut.
- BUCKING - The process of cutting a felled tree or log into lengths.
- LIMBING - The process of removing branches from a fallen tree.
- PRUNING - The process of cutting limbs from a living tree.

SPECIFICATIONS*

Engine Type	Air-Cooled, 2-Cycle
Displacement	46 cc (2.8 cu. in.)
Spark Plug Gap	0.025 in. (0.635 mm)
Spark Plug	Torch® L8RTF or equivalent plug
Lubrication	Bar and Chain Oil
Fuel/Oil Ratio	40:1
Fuel Tank Capacity	18.25 oz. (540 mL)
Chain Oil Reservoir Capacity	8.45 oz. (250 mL)
Approximate Unit Weight (without fuel or chain oil)	14 - 15 lbs. (6.3 - 6.8 kg)
Guide Bar Length	18 in. (45.7 cm)
Saw Chain Pitch	0.325 in. (8.3 mm)
Saw Chain Gauge	0.050 in. (1.3 mm)

* All specifications are based on the latest product information available at the time of printing. We reserve the right to make changes at any time without notice.

ADDING BAR AND CHAIN OIL: INITIAL USE

This unit comes from the factory with the chain oil reservoir empty. Fill the chain oil reservoir with bar and chain oil before starting or using the unit. Refer to *Adding Bar and Chain Oil* instructions in the *Maintenance* section.

ADJUSTING THE CHAIN TENSION: INITIAL USE

The saw chain must be properly tensioned before attempting to start or operate the unit. The saw chain may also require additional tensioning as the saw chain heats up during operation. Refer to *Adjusting the Chain Tension* instructions in the *Maintenance* section.

TESTING THE CHAIN BRAKE

WARNING: Always activate the chain brake slowly and deliberately. Keep the saw chain from touching anything. Do not let the chain saw tip forward.

Always test the chain brake before using the unit.

1. **Set the unit on a flat, level surface.**
 2. Make sure the chain brake lever is pulled back in the disengaged position (Fig. 1).
 3. Start the unit. Refer to *Starting Instructions* in the *Starting and Stopping* section. Maintain a proper grip. Refer to *Holding the Unit* in the *Operation* section.
 4. While the unit is running, squeeze the throttle control to 1/3 throttle and then engage the chain brake by pushing the chain brake lever forward with the left hand (Fig. 1). The chain should stop moving abruptly.
- IF..** If the chain stops moving, the chain brake is working correctly.
- IF..** If the chain does not stop moving, have the unit serviced by an authorized service dealer.
5. Stop the engine and return the chain brake to the disengaged position. Refer to *Stopping Instructions* in the *Starting and Stopping* section.

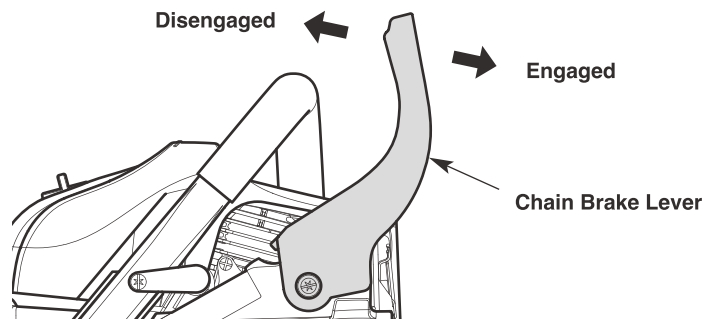

Fig. 1

OIL AND FUEL

OIL AND FUEL MIXING INSTRUCTIONS

The use of old and/or improperly mixed fuel is the most common cause of performance problems. Use only fresh, clean unleaded gasoline. Follow the instructions carefully for the proper gasoline/oil mixture.

Definition of Blended Fuels

Today's fuels are often a blend of gasoline and oxygenates such as ethanol, methanol or MTBE (ether). Alcohol-blended fuel absorbs water. As little as 1% water in the fuel can make fuel and oil separate, forming acids when stored. ALWAYS use fresh fuel (less than 30 days old).

NOTE: Dispose of old fuel according to federal, state and local regulations.

Using Blended Fuels

If using a blended fuel:

- Always use the fresh fuel mix explained in this operator's manual
- Use a fuel additive
- Always agitate the fuel mix before fueling the unit

CAUTION: DO NOT USE E85 FUEL IN THIS UNIT. It has been proven that fuel containing greater than 10% ethanol will likely damage this engine and void the warranty.

Using Fuel Additives

The container of 2-cycle oil provided with this unit includes a fuel additive to help inhibit corrosion and minimize gum deposits. Always use 2-cycle oil that came with this unit. If this is unavailable, use a 2-cycle oil designed for air-cooled engines and mix it with a fuel additive. Add 0.8 oz. (23 ml) of fuel additive per gallon of fuel, according to the instructions on the container. NEVER add fuel additives directly to the unit's fuel tank.

Mixing the Fuel

CAUTION: For proper engine operation and maximum reliability, pay strict attention to the gasoline and oil mixing instructions on the 2-cycle oil container. Using improperly mixed fuel can severely damage the engine.

Thoroughly mix the proper ratio of unleaded gasoline with 2-cycle engine oil. Do not mix them directly in the unit's fuel tank. Use a separate fuel can. Use a 40:1 gasoline/oil ratio. See the table below for specific gasoline and oil mixing ratios.

Unleaded gasoline	2-cycle oil
1 gallon U.S. (3.8 liters)	3.2 fl. oz. (95 ml)
1 liter	25 ml

MIXING RATIO - 40:1

FUELING THE UNIT

WARNING: Gasoline is extremely flammable. Ignited vapors may explode. Always stop the engine and allow it to cool before filling the fuel tank. Do not smoke while filling the tank. Keep sparks and open flames at a distance from the area.

WARNING: Remove the fuel cap slowly to avoid injury from fuel spray. Never operate the unit without the fuel cap securely in place.

WARNING: Add fuel in a clean, well-ventilated outdoor area. Wipe up any spilled fuel immediately. Avoid creating a source of ignition for spilled fuel. Do not start the engine until fuel vapors dissipate.

1. Position the unit with the fuel cap facing up.
2. Slowly remove the fuel cap (Fig. 2).
3. Place the fuel container spout into the fuel tank fill hole and fill the tank.

NOTE: Do not overfill the tank.

4. Wipe up any fuel that may have spilled.
5. Reinstall the fuel cap.
6. Move the unit at least 30 ft. (9.1 m) from the fuel container and the fueling site before starting the engine.

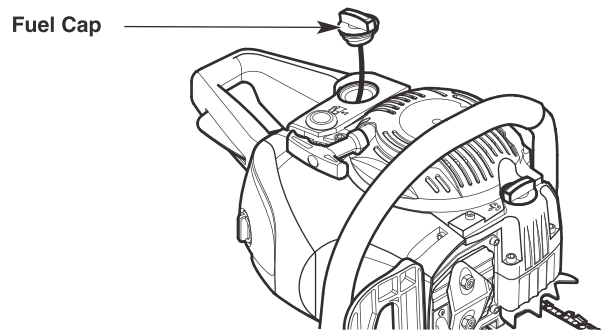

Fig. 2

STARTING AND STOPPING



WARNING: Operate this unit only in a well-ventilated outdoor area. Carbon monoxide exhaust fumes can be lethal in a confined area.



WARNING: Avoid accidentally starting the unit. To avoid serious injury, the operator and the unit must be in a stable position when pulling the starter rope (Fig. 5).



WARNING: Never operate the unit without the guide bar and saw chain properly installed. Make sure the bar-retaining nuts are tight and the guide bar cover is securely assembled. Make sure the saw chain is properly tensioned. Refer to *Adjusting the Chain Tension* instructions in the *Maintenance* section.



WARNING: The saw chain will spin after the engine starts. Keep hands and feet clear of the saw chain and do not allow the saw chain to contact any object(s).

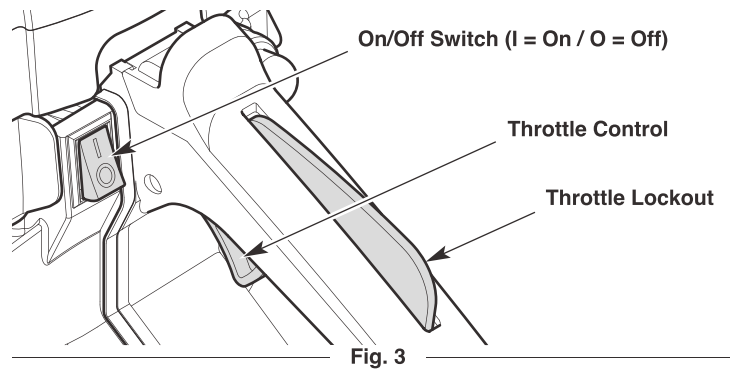

STARTING INSTRUCTIONS

Before Starting the Unit

1. Mix gasoline with oil. Refer to *Oil and Fuel Mixing Instructions*.
2. Fill the fuel tank. Refer to *Fueling the Unit*.
3. Fill the chain oil reservoir with bar and chain oil. Refer to *Adding Bar and Chain Oil* in the *Maintenance* section.
4. Make sure the chain brake is engaged. Refer to *Testing the Chain Brake* in the *Assembly* section.

Starting the Unit

1. Move the On/Off switch to the **On** position (Fig. 3).
2. Slowly press and release the primer bulb **10 times** (Fig. 4). If fuel cannot be seen in the primer bulb, press and release the primer bulb until fuel is visible.
3. Pull the choke knob out to **Position 1** (Fig. 4).

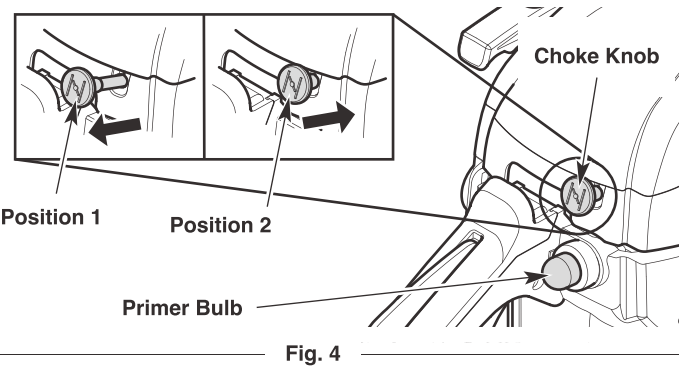

NOTE: DO NOT touch the throttle control (Fig. 3) until step 10.

4. Set the unit on a flat, level surface. Clear the area of any objects that could contact the saw chain.
5. Crouch in the starting position (Fig. 5). Hold the front handle with the left hand. Hold the starter rope grip with the right hand. Insert the right foot into the boot loop to help hold the unit firmly in place.
6. Pull the starter rope with a controlled and steady motion **5 times** (Fig. 5).
7. Push the choke knob in to **Position 2** (Fig. 4).
8. Pull the starter rope with a controlled and steady motion **3 to 5 times** to start the engine.
9. Allow the engine to warm up for 30 to 60 seconds.
10. Press and hold the throttle lockout. Lightly squeeze and release the throttle control to idle the engine.



WARNING: The saw chain should not move when the engine runs at idle. If it does move, refer to *Adjusting the Idle Speed* in the *Maintenance* section.

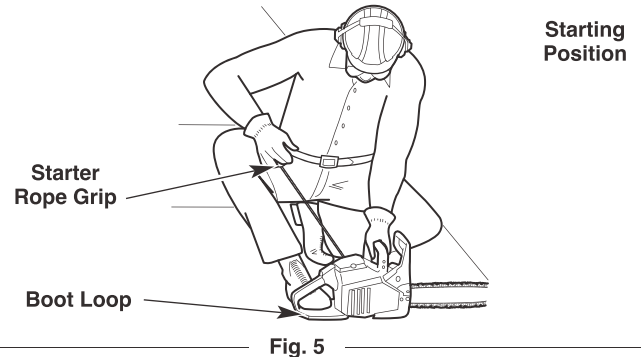

11. To reduce the chance of injury, engage the chain brake until you are ready to begin operation. When ready, disengage the chain brake. Then press the throttle lockout and squeeze the throttle control to accelerate the engine, as needed.

NOTE: The engine is properly warmed up when it accelerates without hesitation.

IF... the engine hesitates, continue the warm-up.

IF... the engine does not start, repeat the starting procedure.

IF... the engine fails to start after a few attempts, move the choke knob to **Position 2**, press the throttle lockout and squeeze the throttle control. Pull the starter rope with a controlled and steady motion until the unit starts.

IF... the engine is already warm, make sure the On/Off switch is in the **On** position, crouch in the starting position, pull the choke knob out to **Position 1** and then push the choke knob back in to **Position 2**. Begin the starting procedure with step 8.

STOPPING INSTRUCTIONS

1. Release the throttle control and allow the engine to idle.
2. Move the On/Off switch to the **Off (O)** position (Fig. 3). Wait for the engine and saw chain to come to a complete stop.

Emergency Stopping

1. Push the chain brake lever forward to engage the chain brake. Refer to *Testing the Chain Brake* in the *Assembly* section.
2. Move the On/Off switch to the **Off (O)** position. Wait for the engine and saw chain to come to a complete stop.

OPERATION



WARNING: Always check the chain tension and adjust as necessary before beginning operation. Refer to *Adjusting the Chain Tension* in the *Maintenance* section.



WARNING: Make sure the chain oil reservoir is full before operation. Check the oil level constantly so that it does not drop below half full. Make sure the chain oil adjustment screw is set appropriately. Refer to *Setting the Chain Oil Adjustment Screw* in the *Maintenance* section. The saw chain must be continuously coated with oil to function properly.



WARNING: Always wear appropriate eye, hearing, hand, foot and body protection to reduce the risk of injury when operating this unit. Wear head protection. Use a full face shield when needed. Refer to the *Safety* section for appropriate safety equipment information.

TIPS FOR BEST RESULTS

- Follow all safety instructions. Refer to the *Safety* section.
- Only cut wood and materials made of wood. Do not attempt to cut sheet metal, plastics, masonry or any other non-wood materials.
- Practice cutting a few small logs before beginning a major cutting operation. First-time users should practice cutting logs on a sawhorse or cradle before undertaking other operations.
- Do not attempt to cut trees or logs with diameters larger than:
 - 12 in. / 30.5 cm (TB4216H XP)
 - 14 in. / 35.6 cm (TB4218H XP)

PREPARING THE WORK AREA

- Clear the area of children, bystanders and pets; keep them outside a 50-foot (15 m) radius, at a minimum. Even then, they are still at risk from thrown objects. Encourage bystanders to wear eye protection. If you are approached, stop the unit immediately. When felling, the safe distance is at least twice the height of the tallest tree in the work area. When bucking, keep workers at least 15 feet (4.6 m) apart.
- Keep the work area clean. Cluttered areas invite injuries. Do not start cutting until the work area is clear and free from obstructions. Make sure there is secure footing and a planned retreat path from falling trees or branches.
- Do not cut near electrical cables or power lines. Keep at least 50 feet (15 m) away from all power lines.
- Use the unit only in daylight or good artificial light.

HOLDING THE UNIT

	<p>WARNING: Always use the hand placements specified below whether the operator is left-handed or right-handed. This will help keep the operator slightly to the left of the unit and out of the direct line of the saw chain if kickback occurs (Fig. 8 and Fig. 9). Always keep all body parts to the left of the chain line.</p>
--	--

- Firmly encircle the handles with the thumbs and fingers (Fig. 6). This will help reduce the chance of losing control of the unit if kickback occurs. Any grip with thumbs and fingers on the same side of the handles is dangerous (Fig. 7).
- Always grip the unit firmly with both hands when the unit is running.
- Hold the front handle with the left hand. Keep the left arm straight to help withstand potential kickback.
- Hold the rear handle with the right hand. Keep the right arm slightly bent.
- Use these hand placements whether the operator is left-handed or right-handed. This will help keep the operator slightly to the left of the unit and out of the direct line of the chain saw if kickback occurs (Fig. 8 and Fig. 9).
- Stand in a stable position with feet apart and firmly planted.
- Do not cut above shoulder height. Do not overreach.

CUTTING PROCEDURE BASICS

1. Start the unit. Refer to *Starting Instructions* in the *Starting and Stopping* section.
2. Keep your fingers off the throttle control until you are ready to make a cut.
3. Accelerate the unit to full speed before cutting.
4. Make sure that oil is flowing onto the guide bar and saw chain. A small spray should be visible. When using the unit for the first time, allow 30-60 seconds for the oil to begin flowing.
5. Press the unit against the wood and maintain a firm, steady pressure through most of the cut. Do not put pressure on the unit at the end of the cut.
6. Maintain a steady speed throughout the cut. Keep the unit running through the entire cut.
7. Do not try to force the saw through the wood. Allow the saw chain to do the cutting. Exert only light pressure. Forcing the cut could result in damage to the unit or personal injury.
8. Release the throttle control as soon as the cut is completed. Allow the saw chain to come to a complete stop. The saw chain, guide bar and engine may experience unnecessary wear if the unit is run without a cutting load.

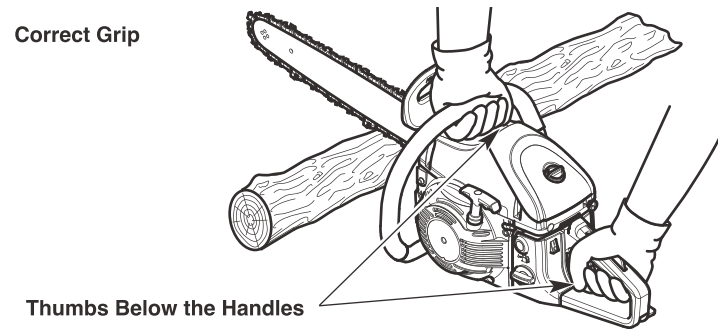

Fig. 6

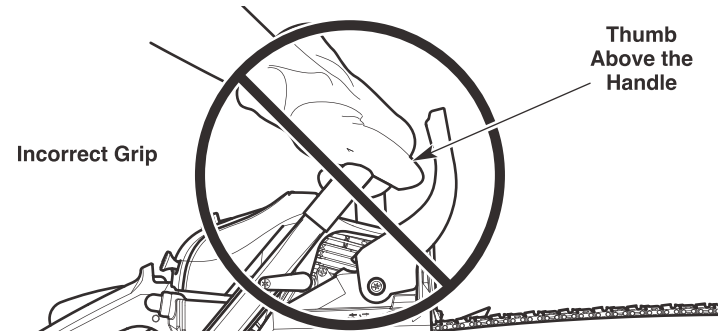

Fig. 7

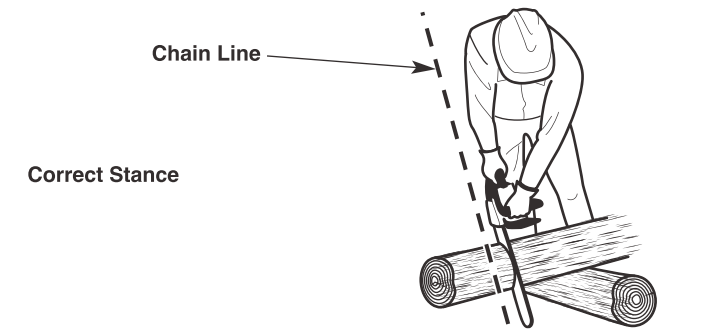

Fig. 8

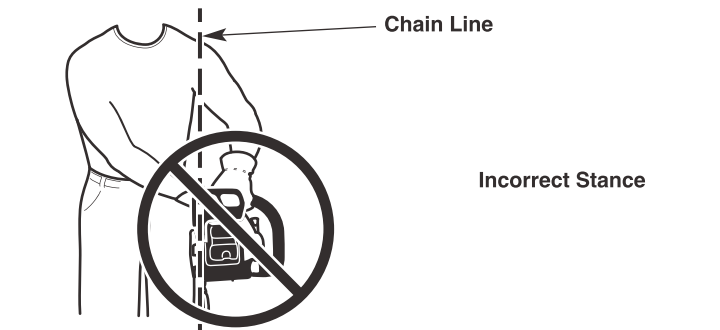

Fig. 9

FELLING: SAFETY

Felling is the process of cutting down a tree. Follow these safety precautions to reduce the risk of serious injury, property damage and damage to electrical lines:

- Do not fell trees with an extreme lean. Do not fell trees with rotten limbs, loose bark or hollow trunks. Have these trees pushed or dragged down with heavy equipment.
- Do not cut trees near buildings or electrical lines. Leave these operations for professionals. If a felled tree does contact an electrical line, notify the utility company immediately.
- Check the tree for damaged or dead branches that could fall and cause serious injury.
- Remove dirt, stones, loose bark, nails, wire and other obstructions from the portion of the tree that will be cut.
- When bucking and felling operations are performed by two or more persons in the same general area, they should be separated from each other by a distance of at least twice the height of the tree to be felled.
- Consider the force and direction of the wind. Consider the lean and balance of the tree. Consider the location of large branches. All of these factors influence the direction that the tree will fall. Do not try to fell a tree in a direction other than its natural fall line.
- Do not fell trees during periods of precipitation or high winds.
- Determine a safe and expedient escape route. Clear the area around the tree and make sure there are no obstructions blocking the escape route. Establish a 90° corridor of escape, approximately 135° from the line of fall (Fig. 10).
- Stay uphill from the tree; it will most likely roll or slide after it falls.

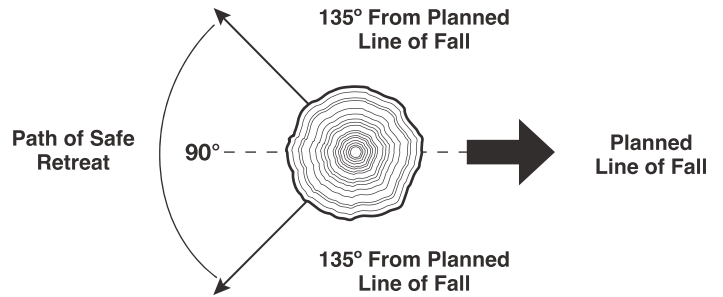

Fig. 10

FELLING: PROCEDURE

Small trees, up to 6 - 7 inches (15 - 18 cm) in diameter, are usually felled in a single cut. Larger trees require a sequence of two cutting operations: a notched undercut followed by a felling back cut. It may also be necessary to remove buttress roots.

Step 1: Removing Buttress Roots

Buttress roots are large roots that extend above the ground and help support the tree. If the tree has large buttress roots that might impede the felling process, follow these steps to remove them:

1. Make a horizontal cut into the buttress root (Fig. 11). To prevent the guide bar from being pinched by the weight of the wood, always make this cut first.
2. Make a vertical cut into the buttress root (Fig. 11).
3. Remove the loose section from the work area.

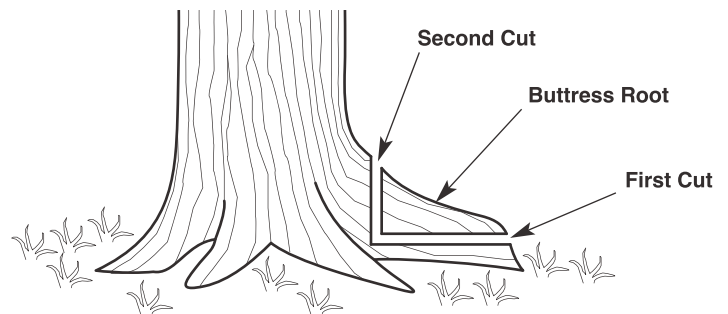
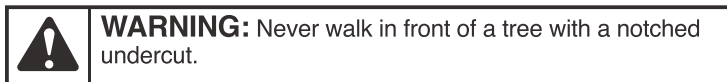

Fig. 11

Step 2: Making the Notched Undercut



This cut determines which direction the tree will fall. Always make this cut on the side of the tree facing the direction where the tree should fall. Make the cut at 90° to the line of fall.

1. Make a horizontal cut into the trunk of the tree (Fig. 12). The cut should be about 1/3 the diameter of the tree and close to the ground. To prevent the guide bar from being pinched by the weight of the wood, always make this cut first.
2. Make a 45° cut into the trunk of the tree, above the first cut (Fig. 12). Continue cutting until the two cuts meet.
3. Remove the loose section from the work area.

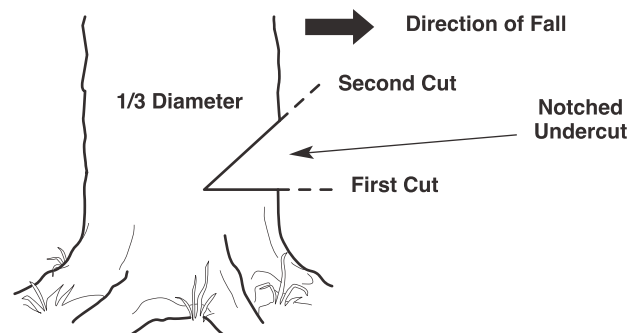

Fig. 12

Step 3: Making the Felling Back Cut



WARNING: Always recheck the area for bystanders, animals and obstacles before making the felling back cut.

This cut fells the tree.

1. Make a horizontal cut into the opposite side of the tree from the notched undercut (Fig. 13). Make the cut approximately 2 inches (5 cm) above the bottom of the notched undercut (Fig. 13).
2. As the cut gets close to the notched undercut, only a thin band of wood will support the tree. This band of wood is referred to as the hinge (Fig. 13). The hinge helps control the fall of the tree. Leave approximately 2 inches (5 cm) of hinge in place. Do not cut through the hinge. Cutting through the hinge could cause the tree to fall in any direction.
3. Periodically glance up during the felling back cut to see if the tree is going to fall in the correct direction. If there is a chance that the tree might not fall in the desired direction, or if the tree might rock back and bind the chain saw, remove the guide bar from the cut, stop the unit and use wedges to open the cut and direct the fall (Fig. 14). Only use soft plastic or wooden wedges. Drive the wedges into the cut slowly. Once the wedges are in place and the cut is held open, either carefully reinsert the guide bar and continue the cut or slowly drive the wedges in further to push the tree over.
4. As the hinge gets smaller, the tree should begin to fall. When the tree begins to fall, remove the chain saw from the cut, stop the engine and set the unit down immediately. Promptly exit the area along the retreat path, but keep watching the tree as it falls.

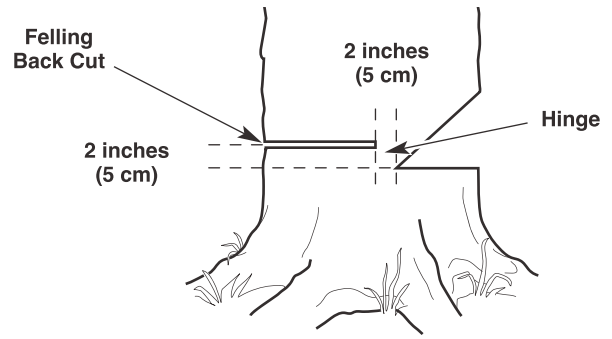

Fig. 13



Fig. 14



DANGER: If the tree starts to fall in the wrong direction and binds the chain saw, leave the unit and evacuate the area immediately! Do not try to save the chain saw!



WARNING: Stay clear of spring poles when operating the unit. Spring poles are branches, logs, roots or saplings that are bent under tension by other wood (Fig. 15). When the tension is released, spring poles can strike the operator, causing serious injury and potentially knocking the chain saw into the operator's body. Use extreme caution when cutting spring poles or when releasing the cause of tension.

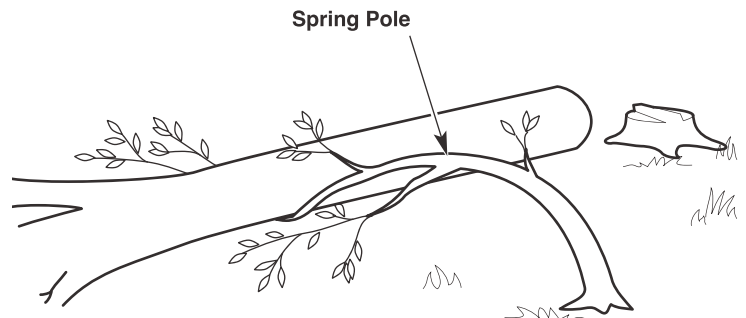

Fig. 15

LIMBING

Limbing is the process of removing branches from a fallen tree.

1. Leave the larger support limbs under the tree for last (Fig. 16). These will keep the tree off the ground during the limbing process.
2. Cut one limb at a time. Stand on the opposite side of the tree from the limb (Fig. 16). Keep the trunk between the operator and the chain saw. To avoid binding the chain saw, branches under tension should be cut from the bottom up.
3. Remove the cut limbs from the work area.

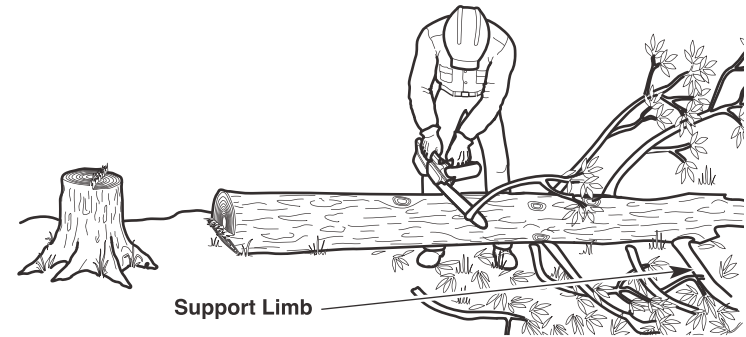

Fig. 16

BUCKING: SAFETY

Bucking is the process of cutting a fallen tree into logs of desired lengths. Follow these safety precautions to reduce the risk of serious injury:

- Clear the area of objects or obstructions that could contact the guide bar and result in kickback.
- When bucking on a slope, always stand on the uphill side of the fallen tree.
- If possible, the end of the tree to be cut should be raised off of the ground. A saw horse is ideal for this purpose. If a saw horse is not available, use other logs or any remaining limb stumps. Make sure the tree is firmly supported.
- Do not let the saw chain contact the ground or saw horse.
- Cut one log at a time. Release the throttle control and allow the saw chain to come to a complete stop before moving on to the next log.
- Keep feet and all other body parts clear of falling logs.



DANGER: Use extreme caution when cutting a fallen tree that is still attached to the root structure. When the trunk is separated from the roots, the stump has a high potential for rocking back into the hole created by the roots. This can result in serious injury or death. Never stand in the hole left by the roots. Never allow others to stand near the root structure.

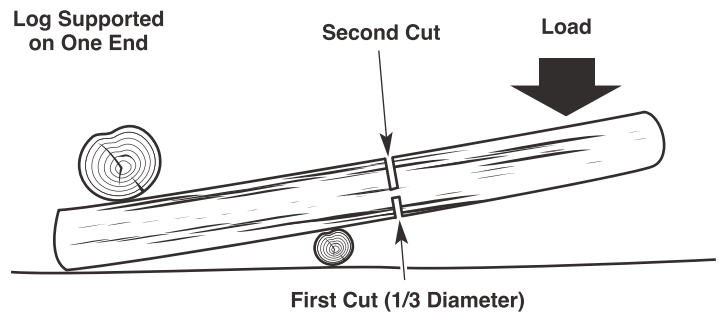

Fig. 17

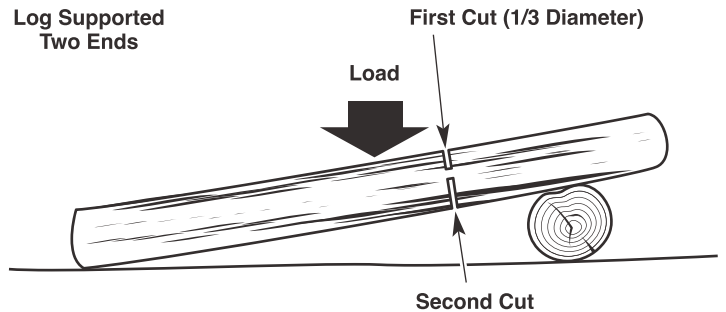

Fig. 18

BUCKING: PROCEDURE

Cutting Logs Under Stress

When logs are supported on one or both ends, the wood tends to bend during the cutting process. This can cause the chain saw to become pinched between the two sides. Pay extra attention.

1. Make the first cut approximately 1/3 the diameter of the log. Do not cut deeper than 1/3.
 - If the log is supported on one end (Fig. 17), make the first cut from below (underbucking). Refer to *Underbucking*.
 - If the log is supported on two ends (Fig. 18), make the first cut from above (overbucking). Refer to *Overbucking*.
2. Make the second cut from the opposite side until the two cuts meet. If the diameter of the wood is large enough, insert soft plastic or wooden wedges to hold the cut open and prevent pinching (Fig. 21). Take care not to touch the wedges with the saw chain.

Cutting Fully-Supported Logs

When logs are supported along the entire length, extra care should be taken to make sure the saw chain does not contact the ground or other support structure (Fig. 19).

1. Cut through the log as much as possible, without cutting into the ground or support structure. Cut from above (overbucking). Refer to *Overbucking*.
2. Roll the log over and finish cutting through the log from above (overbucking).

Overbucking

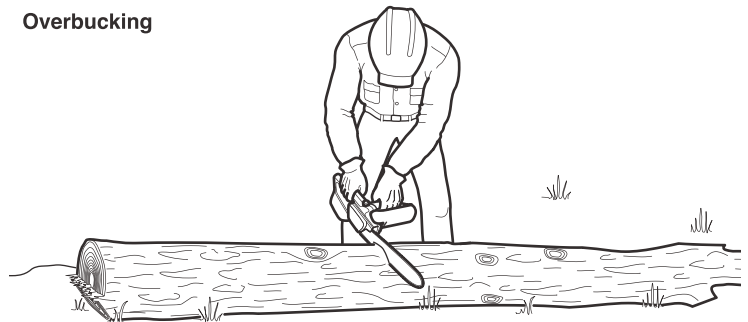

Fig. 19

Underbucking

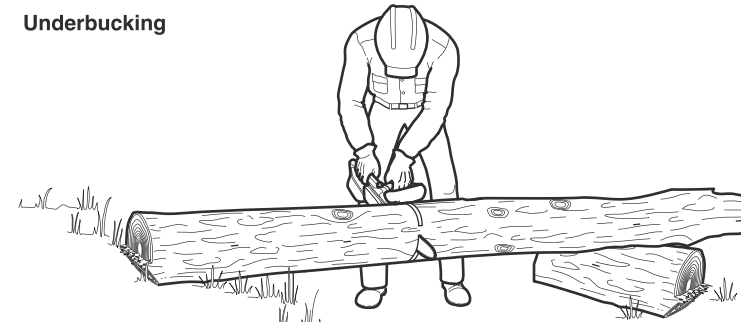

Fig. 20

Overbucking

1. Begin cutting from above, with the bottom of the saw chain against the top of the log (Fig. 19).
2. Exert light, downward pressure. The saw will tend to pull away from the operator. Be prepared and hold the saw firmly to maintain control.

Underbucking

1. Begin cutting from below, with the top of the saw chain against the bottom of the log (Fig. 20).
2. Exert light, upward pressure. The saw will tend to push toward the operator. Be prepared and hold the saw firmly to maintain control.



Fig. 21

PRUNING



WARNING: Do not cut above shoulder height with a chain saw. Use a pole saw to cut limbs above shoulder height or hire a professional. Do not operate the unit in a tree or on a ladder unless specifically trained to do so.



WARNING: Falling branches can cause serious injury. Always wear appropriate head protection. Plan an escape route away from falling limbs. Do not position any body parts directly below the limb when cutting.

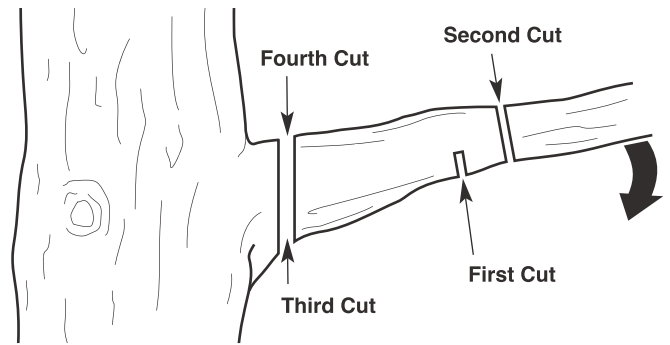

Fig. 22

Pruning is the process of cutting limbs from a living tree.

1. Make the first cut approximately 6 inches (15 cm) from the tree trunk. Cut upward, from the underside of the limb. Use the top of the guide bar to make this cut. Cut a third of the way through the diameter of the limb (Fig. 22).
2. Make the second cut 2 - 4 inches (5 - 10 cm) farther out on the limb. Cut downward, from the top of the limb. Use the bottom of the guide bar to make this cut. Cut completely through the limb (Fig. 22).
3. Make the third cut as close to the tree trunk as possible. Cut upward, from the underside of the limb stub. Use the top of the guide bar to make this cut. Cut a third of the way through the diameter of the limb (Fig. 22).
4. Make the fourth cut directly above the third cut. Cut downward, from the top of the limb stub. Use the bottom of the guide bar to make this cut. Cut completely through the limb stub to meet the third cut (Fig. 22). This will remove the limb stub.

MAINTENANCE



WARNING: To avoid serious personal injury, always stop the engine and allow it to cool before cleaning or maintaining the unit. Never perform cleaning or maintenance while the unit is running. Disconnect the spark plug wire to prevent the unit from starting accidentally.



WARNING: Wear protective clothing and observe all safety instructions to prevent serious personal injury.

MAINTENANCE SCHEDULE

Perform these required maintenance procedures at the frequency stated in the table. These procedures should also be a part of any seasonal tune-up.

All service, other than the maintenance procedures described in this manual, should be performed by an authorized service dealer.

NOTE: Some maintenance procedures may require special tools or skills. If you are unsure about these procedures, take the unit to an BILT HARD authorized service dealer.

NOTE: Maintenance, replacement, or repair of the emission control devices and system may be performed by an BILT HARD authorized service dealer.

CUSTOMER RESPONSIBILITY

FREQUENCY	MAINTENANCE REQUIRED
Before each use	<ul style="list-style-type: none"> • Check for loose screws, nuts or bolts (tighten as needed) • Check for damaged or worn parts* • Check the saw chain sharpness. Refer to <i>Sharpening the Saw Chain</i>. • Test the chain brake*. Refer to <i>Testing the Chain Brake</i>. • Check the chain tension (adjust as needed). Refer to <i>Adjusting the Chain Tension</i>. • Fill the chain oil reservoir (refill frequently). Refer to <i>Adding Bar and Chain Oil</i>. • Fill the fuel tank with fresh, properly mixed fuel. Refer to the <i>Oil and Fuel</i> section. • Clean the air filter. Refer to <i>Maintaining the Air Filter</i>.
After each use	<ul style="list-style-type: none"> • Clean the unit and inspect decals. Refer to <i>Cleaning</i> in the <i>Cleaning and Storage</i> section.
Every 10 hours	<ul style="list-style-type: none"> • Check the spark plug condition and gap. Refer to <i>Maintaining the Spark Plug</i>. • Clean the guide bar groove and oil passages. Lubricate the sprocket tip. Refer to <i>Maintaining the Guide Bar</i>. • Clean the cylinder fins. Refer to <i>Cleaning</i> in the <i>Cleaning and Storage</i> section.

* If maintenance or replacement is required, have the unit serviced by an BILT HARD authorized service dealer.

ADDING BAR AND CHAIN OIL

DANGER: Failure to fill the chain oil reservoir will cause irreparable damage to the unit. Make sure the chain oil reservoir is always filled. Always use bar and chain oil.

WARNING: Oil constantly flows from the chain oil reservoir to oil the saw chain. Check the chain oil level frequently so that it does not drop below half full.

The guide bar and saw chain require lubrication to minimize friction. Never starve the guide bar and chain of lubricating oil. Running the unit without enough oil will decrease cutting efficiency, shorten the life of the saw chain, cause rapid dulling of the saw chain and excessive wear to the guide bar from overheating. An insufficient amount of lubricating oil is evidenced by smoke, guide bar discoloration or pitch build-up.

Only use bar and chain oil that is formulated to perform over a wide range of temperatures with no diluting required in the chain oil reservoir. Do not use motor oil or any other petroleum-based oil. Do not use dirty, used or contaminated oil. Damage may occur to the guide bar or saw chain. Dispose of old oil according to federal, state and local regulations.

1. **Set the unit on a flat, level surface.**
2. To prevent debris from entering the chain oil reservoir, use a damp cloth to clean the chain oil cap and surrounding area.
3. Unscrew the chain oil cap (Fig. 23).
4. Carefully pour the oil into the chain oil reservoir. **DO NOT** overfill.
5. Reinstall the chain oil cap. Tighten the cap firmly.
6. Wipe up any oil that may have spilled.

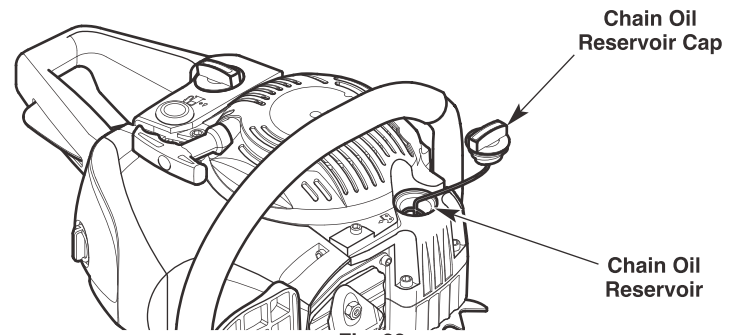

Fig. 23

ADJUSTING THE BAR AND CHAIN OIL FLOW

Bar and chain oil will slowly flow from the chain oil reservoir onto the chain. Approximately one tank of bar and chain oil is used for every tank of fuel.

1. To increase the oil flow, turn the automatic oiler adjustment screw counterclockwise with a flat-head screwdriver (Fig. 24).
2. To decrease the oil flow, turn the automatic oiler adjustment screw clockwise with a flat-head screwdriver (Fig. 24).

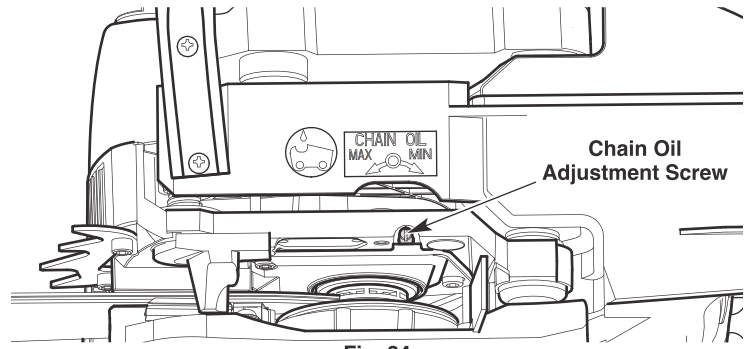

Fig. 24

ADJUSTING THE CHAIN TENSION



CAUTION: The guide bar, saw chain, and saw bearings will wear more rapidly if the saw chain is not properly tensioned. Maintaining proper chain tension will improve cutting performance and prolong the life of the saw chain.



WARNING: To prevent serious injury, never touch the saw chain or adjust the chain tension while the unit is running. Disconnect the spark plug wire to prevent the unit from starting accidentally.



WARNING: The saw chain is very sharp. Always wear heavy-duty protective gloves when handling or performing maintenance on the saw chain.

Check the chain tension before and during operation. The saw chain will expand as it heats up during operation. Adjust the chain tension whenever the flats on the saw chain hang out of the bar groove (Fig. 25 and Fig. 26).

NOTE: A new saw chain tends to stretch and will need readjustment after as few as five (5) cuts. This is normal during the break-in period. The interval between future adjustments will lengthen quickly.

1. Make sure the chain brake is disengaged. Refer to *Testing the Chain Brake* in the *Assembly* section.
2. Use the srench or a 1/2 inch (13 mm) wrench to slightly loosen the bar-retaining nuts (Fig. 27). **DO NOT** remove the bar cover.
3. Hold the guide bar tip up and use a flat-head screwdriver to turn the chain-tensioning screw (Fig. 27).
 - Turn the chain-tensioning screw clockwise to tighten the saw chain.
 - Turn the chain-tensioning screw counterclockwise to loosen the saw chain.

The saw chain should fit snugly against the underside of the guide bar. There should be no sag (Fig. 26).

4. Continue to hold the guide bar tip up and move the saw chain back and forth along the guide bar (Fig. 28). Make sure the saw chain moves freely and is in proper mesh with the sprocket. If the saw chain does not move easily, slowly turn the chain-tensioning screw counterclockwise to loosen the saw chain.

NOTE: The saw chain will not move if the chain brake is engaged.

5. Continue to hold the guide bar tip up and securely tighten the bar-retaining nuts.



CAUTION: If the saw chain was tensioned while warm, it may become too tight when cooled. Loosen the chain tension after operation and check the chain tension before the next use.

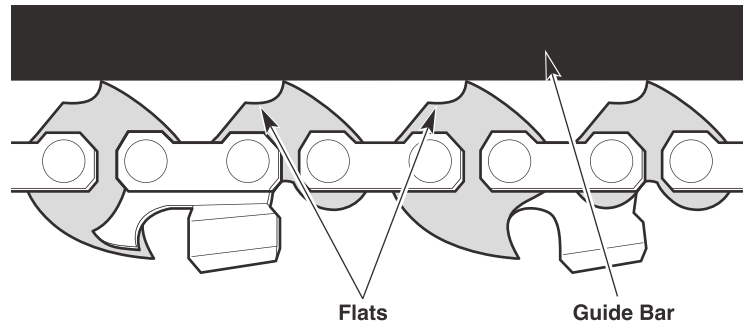

Fig. 25

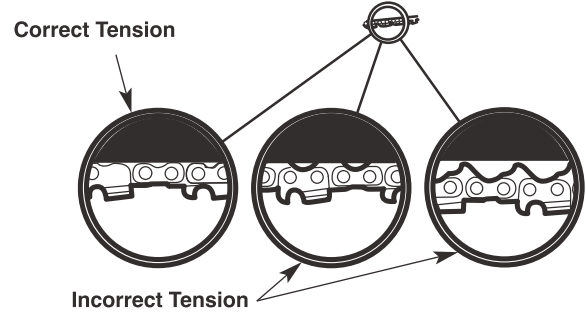

Fig. 26

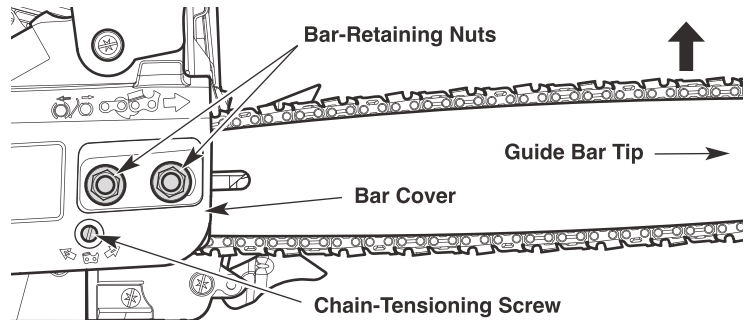

Fig. 27

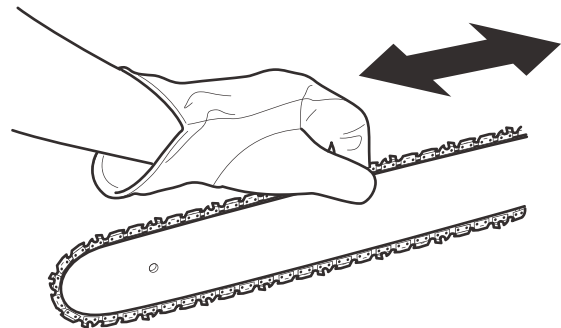

Fig. 28

REMOVING AND INSTALLING THE GUIDE BAR AND SAW CHAIN



WARNING: The saw chain is very sharp. Always wear heavy-duty protective gloves when handling or performing maintenance on the saw chain.

The guide bar and saw chain need to be removed when certain maintenance procedures are performed, such as when rotating the guide bar. When replacing old guide bars and saw chains with new parts, always use the manufacturer's specified replacement parts. Refer to *Replacing the Guide Bar and Saw Chain*.

Removing the Guide Bar and Saw Chain

1. Make sure the chain brake is disengaged. Refer to *Testing the Chain Brake* in the *Assembly* section.
2. Use the screwdriver or a 1/2 inch (13 mm) wrench to loosen the bar-retaining nuts (Fig. 29).
3. Remove the bar-retaining nuts and bar cover (Fig. 29).
4. Loosen the saw chain. Refer to *Adjusting the Chain Tension*.
5. Remove the guide bar and saw chain from the guide bar bolts (Fig. 31).
6. Remove the saw chain from the guide bar.

Installing the Guide Bar and Saw Chain

1. Set the saw chain on a clean, flat surface and straighten out any kinks.
2. Fit the saw chain into the guide bar groove (Fig. 30). Make sure the cutters point in the correct direction of rotation (Fig. 30). Keep a loop of saw chain at the back end of the guide bar (Fig. 30).
3. Hold the saw chain and guide bar together in position over the unit. Loop the saw chain around the drive sprocket and install the guide bar onto the guide bar bolts (Fig. 31). Make sure the guide bar is flush against the mounting surface. Make sure the flats on the saw chain are in the grooves on the drive sprocket.
4. Install the bar cover. Make sure the chain-tensioning pin is in the pin hole on the guide bar (Fig. 32).
5. Place the bar-retaining nuts onto the guide bar bolts and tighten them hand tight. **DO NOT** tighten the bar-retaining nuts completely.
6. Make sure the saw chain is still in the guide bar groove. Adjust the chain tension. Refer to *Adjusting the Chain Tension*.
7. Hold the guide bar tip up and securely tighten the bar-retaining nuts.

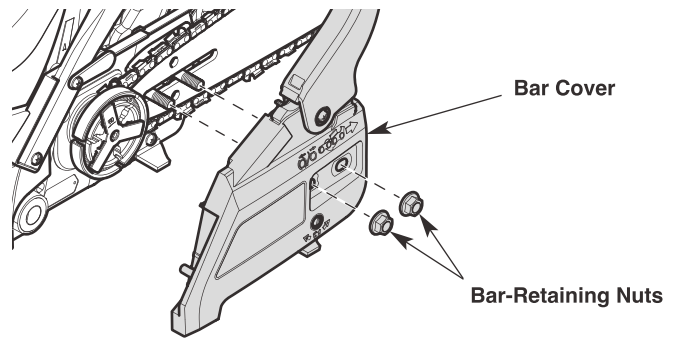

Fig. 29

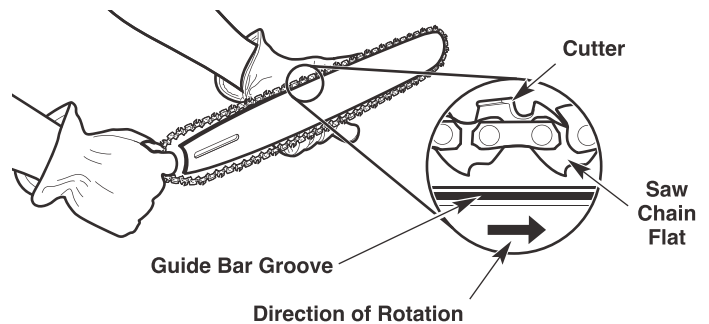

Fig. 30

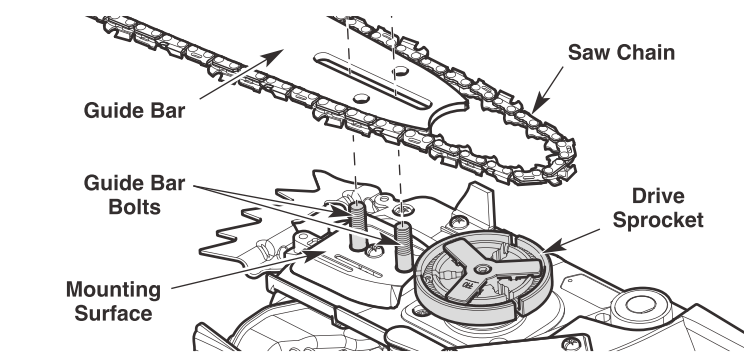

Fig. 31

MAINTAINING THE SAW CHAIN

For safe, efficient operation, the saw chain must be maintained properly. The saw chain will wear with use, causing the chain to stretch. This is normal. When it is no longer possible to obtain a correct chain-tension adjustment, the saw chain will need to be repaired by an authorized service dealer or replaced. Refer to *Replacing the Guide Bar and Saw Chain*.

Always keep the saw chain sharp. During operation, look for the following indicators of a dull saw chain:

- Wood chips are small and powdery.
- The saw chain must be forced through the wood.
- The saw chain cuts to one side.

If any of these conditions exist, sharpen or replace the saw chain. Refer to *Sharpening the Saw Chain* or *Replacing the Guide Bar and Saw Chain*.

NOTE: If you do not fully understand the process for properly sharpening a saw chain after reading the instructions, have the saw chain sharpened by an authorized service center or replace the saw chain.

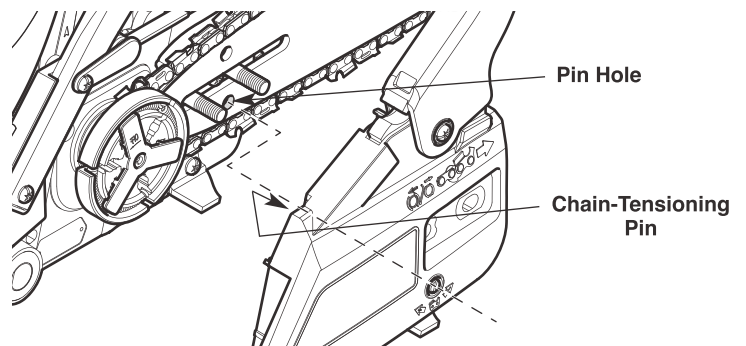

Fig. 32

SHARPENING THE SAW CHAIN



WARNING: The saw chain is very sharp. Always wear heavy-duty protective gloves when handling or performing maintenance on the saw chain.



WARNING: An improperly sharpened saw chain increases the chance of kickback. Failure to replace or properly maintain the saw chain can cause serious injury.



CAUTION: A dull or improperly sharpened saw chain can cause excessive engine speed during operation, which can result in severe engine damage.

If the saw chain was damaged by contacting hard objects, such as nails or stones, or was abraded by mud or sand on the wood, have an authorized service dealer sharpen the saw chain.

When sharpening the saw chain, file all cutters to the specified angles and measurements. Other angles or measurements can cause excessive wear to the guide bar and saw chain, cause the chain to dull quickly and increase the chance of kickback. Fast cutting can be obtained only when all cutters are uniform.

1. Tighten the chain tension so that the saw chain is taut and does not wobble. Refer to *Adjusting the Chain Tension*.
 - Always file the saw chain at the midpoint of the guide bar.
2. Use a round file and file holder (tools not included) to sharpen the top plate and side plate of each cutter.
 - Use a 5/32 inch (4 mm) diameter file.
 - Keep the file level with the top plate of the cutter (Fig. 33). Do not let the file dip or rock. Use light, but firm pressure.
 - File toward the front corner of the cutter (Fig. 34). Lift the file away from the cutter at the end of the forward stroke. Only file on the forward stroke.
 - Apply a few firm strokes to each tooth. When filed correctly, the top plate will be at a 30° angle and the side plate will be at an 80° angle (Fig. 35). Using the correct file and file holder will automatically produce the correct angles.
 - File all the left-hand cutters in one direction (Fig. 34). Then move to the other side of the saw chain and file all of the right-hand cutters in the opposite direction (Fig. 34).
 - Occasionally remove filings with a wire brush.
3. Use a depth gauge tool (not included) to measure the depth gauge clearance (Fig. 36) of each cutter. The depth gauge clearance must be maintained at 1/32 inch (0.6 mm). The depth gauge clearance determines the depth at which the cutter enters the wood during operation and the size of the wood chips produced. Too much clearance increases the chance of kickback. Too little clearance decreases the size of the wood chips, thus decreasing the ability to cut.
 - Use a 1/32 inch (0.6 mm) depth gauge jointer and a flat file (tools not included) to lower the depth gauge to the correct clearance (Fig. 36).
 - After lowering the depth gauge, use the flat file to restore the original rounded shape to the depth gauge (Fig. 37). Take care not to damage the cutting edges or nearby links.

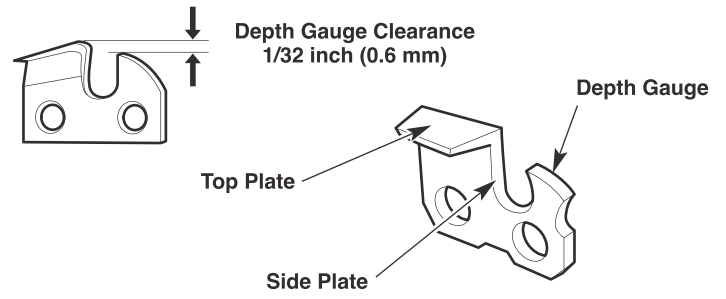

Fig. 33

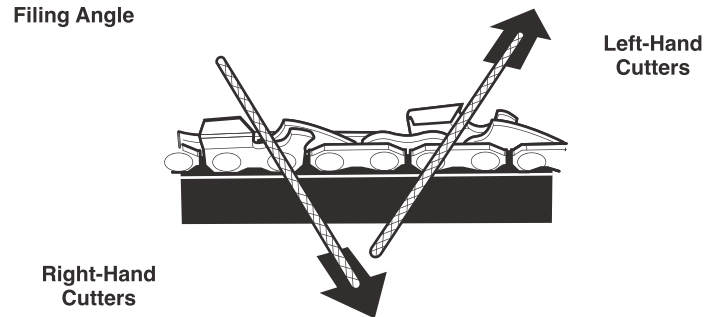

Fig. 34

Correct Filing Angles

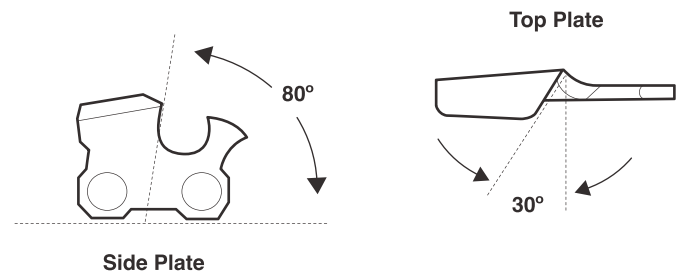

Fig. 35

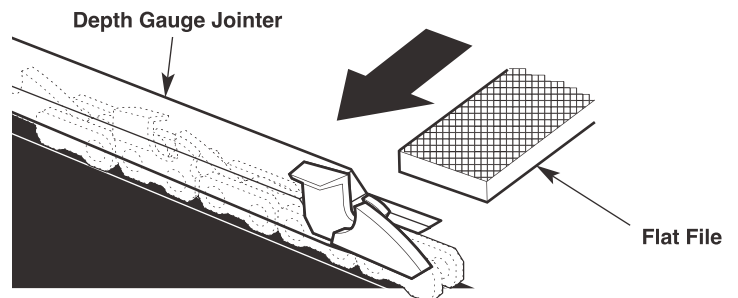

Fig. 36

Restore original rounded shape

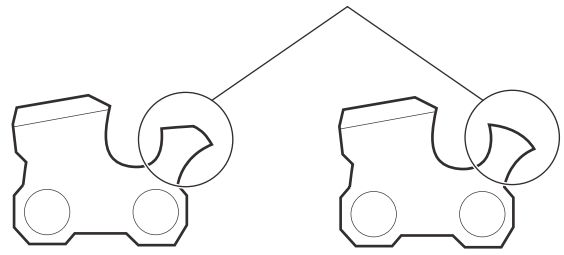

Fig. 37

MAINTAINING THE GUIDE BAR

1. Rotate the guide bar frequently, at regular intervals (for example, after every 5 hours of operation), to ensure even wear on the top and bottom of the guide bar. Refer to *Removing and Installing the Guide Bar and Saw Chain*.
2. Clean the guide bar groove and oil passages whenever the saw chain is removed, when the unit has been used heavily or when the saw chain appears dirty. Use a screwdriver, putty knife, wire brush or similar instrument to remove debris from the guide bar groove (Fig. 38). Use a small, soft wire to remove any debris from the chain oil discharge hole (Fig. 39).

NOTE: If the oil passages are clear, the saw chain will give off a spray of oil shortly after it begins to rotate during operation.

3. Frequently check the guide bar for damage (Fig. 40). Feathering and burring of the guide bar rails (the ridges on either side of the bar groove) is a normal process of guide bar wear. Such faults should be smoothed with a file as soon as they occur (Fig. 40). A guide bar with the following faults should be replaced:
 - Wear inside the guide bar rails that permits the chain to lay sideways
 - Bent guide bar
 - Cracked or broken rails
 - Spread rails

Refer to *Replacing the Guide Bar and Saw Chain*.

Lubricating the Guide Bar Sprocket Tip

The guide bar sprocket tip was lubricated at the factory, but requires regular lubrication. Failure to lubricate the guide bar sprocket tip will result in poor performance, damage to the unit and will VOID the warranty.

NOTE: This procedure can be performed while the guide bar and saw chain are still assembled on the unit.

1. Clean the guide bar sprocket tip thoroughly with a damp cloth (Fig. 41).
2. Use a guide bar tip lube gun (not included) to inject grease into the lubrication hole (Fig. 41). Inject grease until it appears on the outer edge of the guide bar sprocket tip.
3. Rotate the saw chain by hand. Always wear heavy-duty protective gloves. Make sure the chain brake is disengaged.
4. Repeat the lubrication process until the entire guide bar sprocket tip is lubricated.

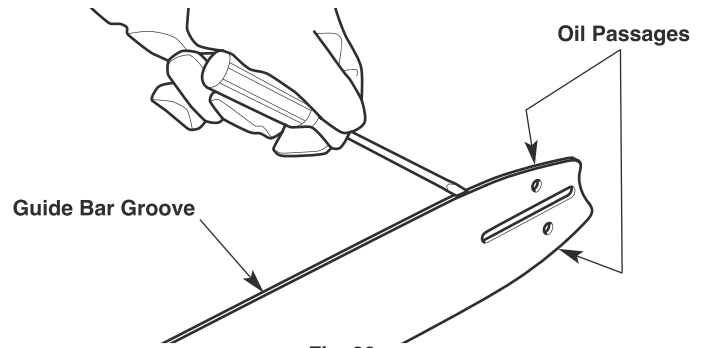

Fig. 38

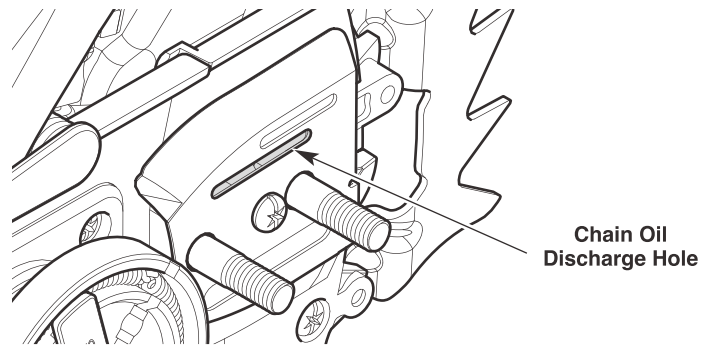

Fig. 39

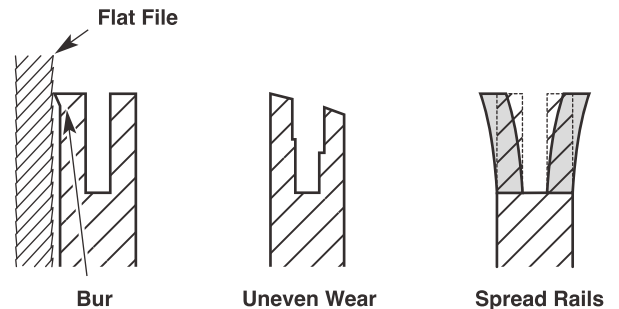

Fig. 40

REPLACING THE GUIDE BAR AND SAW CHAIN



WARNING: Always use a low-kickback saw chain, which significantly reduces the danger of kickback. Low-kickback saw chain does not completely eliminate kickback. A low-kickback or “safety chain,” should never be regarded as total protection against injury.

When replacing the guide bar and saw chain, only use the replacement parts specified by the manufacturer or their equivalents. Refer to *Replacement Parts*. Use of any unauthorized parts or accessories could lead to serious injury to the operator or damage to the unit and will VOID the warranty.

Always use a replacement saw chain designated as “low-kickback” or a saw chain that meets the low-kickback performance requirements. A standard saw chain (a chain that does not have the kickback-reducing guard links) should only be used by an experienced professional chain saw operator.

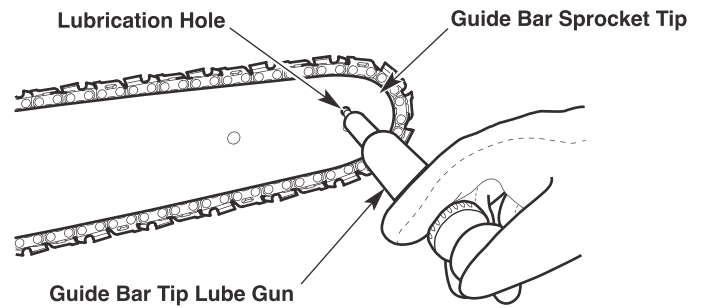

Fig. 41

MAINTAINING THE AIR FILTER



WARNING: To avoid serious personal injury, always stop the engine and allow it to cool before cleaning or maintaining the unit.

Failure to maintain the air filter can result in poor performance or can cause permanent damage to the engine. Engine failure due to improper air filter maintenance is not covered by the product warranty.

Cleaning the Air Filter

1. Turn the knob on the air filter cover counterclockwise to loosen the air filter cover (Fig. 42).
2. Remove the air filter cover (Fig. 42).
3. Remove the air filter (Fig. 43).
4. Wash the air filter in mild detergent and water. Rinse the air filter thoroughly and allow it to dry.
5. Reinstall the air filter onto the mounting post (Fig. 43). Make sure the opening in the air filter sits securely in the air intake (Fig. 43).

NOTE: Operating the unit without the air filter and air filter cover will VOID the warranty. Keep a supply of spare air filters.

6. Place the air filter cover back onto the unit. Insert the two tabs on the air filter cover into the two slots on the chain saw housing (Fig. 42).
7. Turn the knob clockwise to tighten the air filter cover securely.

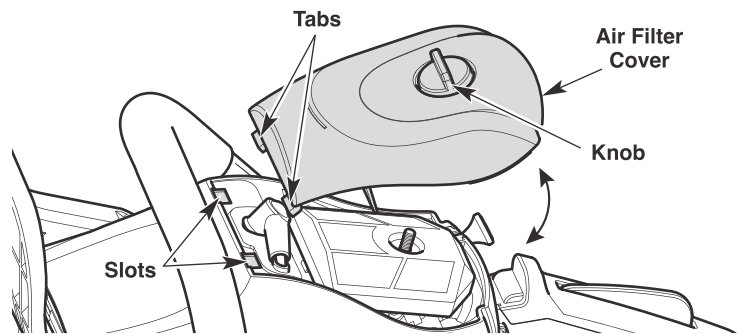

Fig. 42

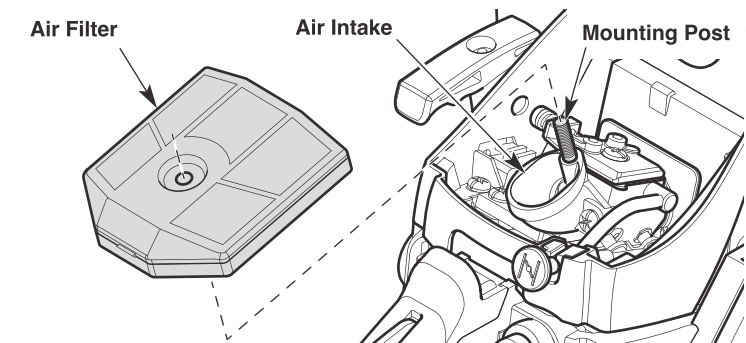

Fig. 43

ADJUSTING THE IDLE SPEED



WARNING: The saw chain may spin during idle speed adjustments. Wear protective clothing and observe all safety instructions to prevent serious personal injury.

If the engine will not idle properly:

1. Start the engine. Refer to *Starting and Stopping*.
2. Release the throttle control and let the engine idle.
 - If the engine stops, increase the idle speed. Use a small Phillips screwdriver to turn the idle speed screw clockwise, 1/8 of a turn at a time, until the engine idles smoothly (Fig. 44).
 - If the saw chain spins when the engine idles, reduce the idle speed. Turn the idle speed screw counterclockwise, 1/8 of a turn at a time, until the saw chain stops moving (Fig. 44).

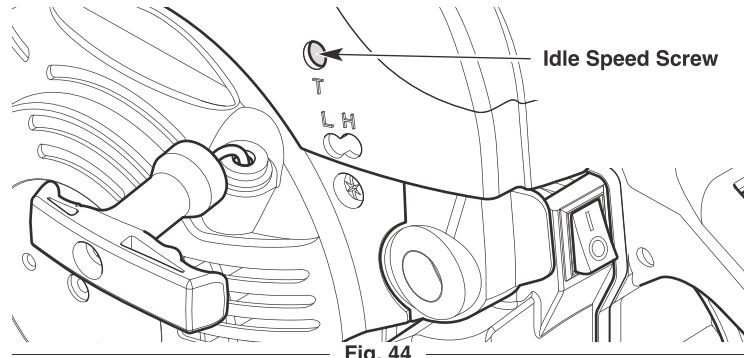

Fig. 44

MAINTAINING THE SPARK PLUG

1. Stop the engine and allow it to cool.
2. Turn the knob on the air filter cover counterclockwise to loosen the air filter cover (Fig. 42).
3. Remove the air filter cover (Fig. 42).
4. Grasp the spark plug boot firmly and pull it from the spark plug (Fig. 45).
5. Clean around the spark plug. Remove the spark plug from the cylinder head with the srench or a 5/8-inch socket wrench, turning counterclockwise.



WARNING: Do not sand blast, scrape or clean spark plug electrodes. Grit in the engine could damage the cylinder.

6. Inspect the spark plug. If the spark plug is cracked, fouled or dirty, replace it with replacement part #794-00204, a **Torch CMR7H** or an equivalent spark plug.
7. Use a feeler gauge to set the air gap at **0.025 in. (0.635 mm)** (Fig. 46).
8. Install the spark plug in the cylinder head. Tighten the spark plug with the srench or a 5/8-inch socket wrench, turning it clockwise until snug.

NOTE: If using a torque wrench, torque to:

110-120 in.·lb. (12.3-13.5 N·m). Do not over tighten.

9. Reattach the spark plug boot.
10. Place the air filter cover back onto the unit. Insert the two tabs on the air filter cover into the two slots on the chain saw housing (Fig. 42).
11. Turn the knob clockwise to tighten the air filter cover securely.

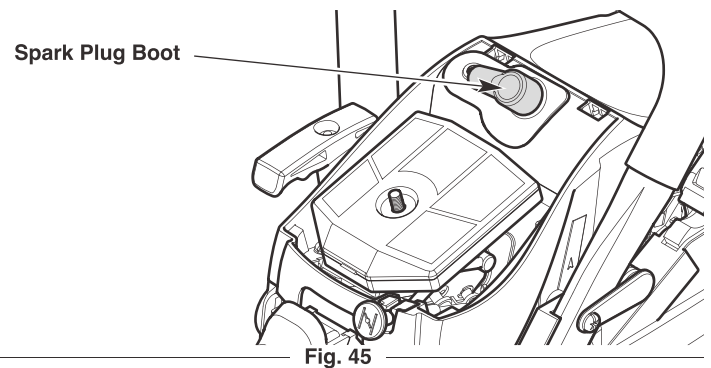

Fig. 45

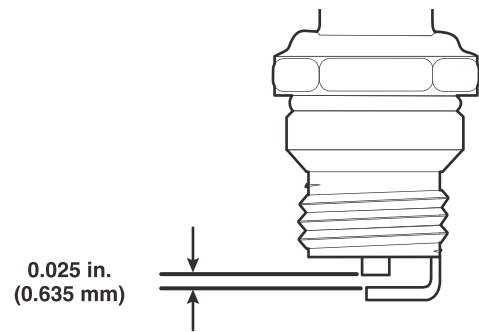

Fig. 46

CLEANING AND STORAGE

CLEANING



WARNING: To avoid serious personal injury, always stop the engine and allow it to cool before cleaning or maintaining the unit.

1. Loosen the saw chain if the chain tension was adjusted during operation. The saw chain will contract as the unit cools, which could damage the unit if the chain is too tight.
2. Clean the unit with a damp cloth. Do not douse the unit with water. Do not use strong detergents. Household cleaners that contain aromatic oils such as pine and lemon, and solvents such as kerosene, can damage plastic.

NOTE: When preparing the unit for long-term storage (30 days or more), remove the guide bar and saw chain. Carefully clean the guide bar cover, guide bar mounting surface and sprocket. Use a firm non-wire brush to clean the guide bar groove. Reassemble the unit.

3. Wipe off any moisture with a soft cloth.
4. Use compressed air, up to 40 PSI, to blow debris from the cylinder fins (Fig. 47). The cylinder fins must be cleaned on a regular basis to reduce the risk of personal injury or damage to the unit as a result of fire. Always use safety goggles/glasses when using compressed air. Do not use water or other liquids to clean the cylinder fins. Use a small wire brush to remove stubborn debris. If a significant amount of debris remains, have the unit cleaned by an authorized service dealer.
5. Lightly coat the guide bar and saw chain with a corrosion-inhibiting oil.

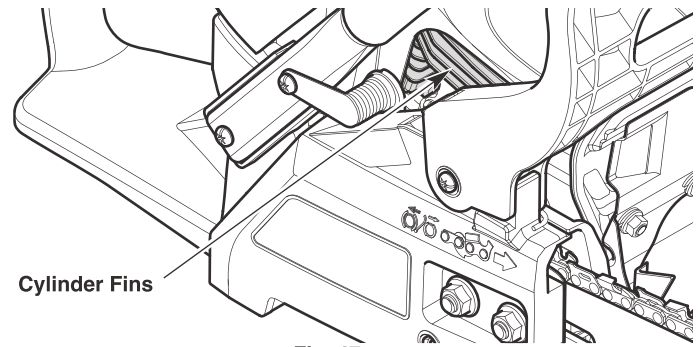

Fig. 47

STORAGE

- Loosen the saw chain if the chain tension was adjusted during operation. The saw chain will contract as the unit cools, which could damage the unit if the chain is too tight.
- Allow the engine to cool before storing.
- Thoroughly clean the unit and inspect it for any loose or damaged parts. Repair or replace damaged parts and tighten loose screws, nuts or bolts.
- Cover the guide bar and saw chain with the scabbard.
- Never store a fueled unit where fumes may reach an open flame or spark.
- Lock up the unit to prevent unauthorized use or damage.
- Store the unit in a dry, well-ventilated area.
- Store the unit out of the reach of children.

NOTE: It is normal for bar and chain oil to seep from the unit when not in use. Please take this into consideration when storing the unit.

Long-term Storage (30 days or more)

1. Remove the fuel cap, tip the unit and drain the fuel into an approved container. Reinstall the fuel cap.
2. Start the engine and allow it to run until it stalls. This ensures that all fuel has been drained from the carburetor.
3. Allow the engine to cool. Remove the spark plug and put 5 drops of any high-quality motor oil or 2-cycle oil into the cylinder. Pull the starter rope slowly to distribute the oil. Reinstall the spark plug.

Preparing the Unit for Use after Long-term Storage

1. Remove the spark plug. Tip the unit and drain all of the oil from the cylinder into an approved container. Reinstall the spark plug.

NOTE: Do not use fuel that has been stored for more than 30 days. Dispose of old fuel and oil according to federal, state and local regulations.

TROUBLESHOOTING

THE ENGINE WILL NOT START

The fuel tank is empty	Fill the fuel tank with properly-mixed fuel
The primer bulb was not pressed enough	Press the primer bulb 10 times or until fuel is visible
The engine is flooded	Turn off the switch, move the choke knob to Position 2, press the throttle lockout, squeeze the throttle control and pull the starter rope
The fuel is old (over 30 days) and/or improperly mixed	Drain the fuel tank and add fresh, properly-mixed fuel
The spark plug is not working properly	Refer to <i>Maintaining the Spark Plug</i>
The On/Off switch is in the Off (O) position	Move the On/Off switch to the On (I) position

THE ENGINE WILL NOT IDLE

The air filter is dirty	Clean or replace the air filter
The fuel is old (over 30 days) and/or improperly mixed	Drain the fuel tank and add fresh, properly-mixed fuel
The idle speed is incorrect	Adjust the idle speed

THE ENGINE WILL NOT ACCELERATE

The fuel is old (over 30 days) and/or improperly mixed	Drain the fuel tank and add fresh, properly-mixed fuel
The air filter is dirty	Clean or replace the air filter

THE ENGINE LACKS POWER OR STALLS

The fuel is old (over 30 days) and/or improperly mixed	Drain the fuel tank and add fresh, properly-mixed fuel
The air filter is dirty	Clean or replace the air filter
The spark plug is not working properly	Refer to <i>Maintaining the Spark Plug</i>

THE SAW CHAIN COMES OFF THE GUIDE BAR

The saw chain tension is too loose	Adjust the saw chain tension
The guide bar and saw chain are assembled incorrectly	Refer to <i>Removing and Installing the Guide Bar and Saw Chain</i>

THE GUIDE BAR AND SAW CHAIN ARE RUNNING HOT, SMOKING OR STUCK

The saw chain tension is too tight	Adjust the saw chain tension
The chain oil reservoir is empty	Refill the chain oil reservoir
The guide bar groove and oil passages are dirty	Clean the guide bar and oil passages
The automatic oiler flow is too low	Increase the oil flow
If it is smoke from the exhaust port	It is possible that there is too much oil in the engine. (Need to mix gasoline and oil in the ratio of 40:1)
If the smoke is coming from the clutch	It is possible that the chain oil is flowing into the clutch because the guide plate is not installed properly.
If the brake is not released	It will also lead to heat and smoke when starting

THE SAW CHAIN DOES NOT ROTATE

The saw chain tension is too tight	Adjust the saw chain tension
The guide bar and saw chain are assembled incorrectly	Refer to <i>Removing and Installing the Guide Bar and Saw Chain</i>
The guide bar and saw chain are damaged	Inspect the guide bar and saw chain for damage. Replace them if necessary
The drive assembly is damaged	Refer to <i>Service</i> information
The chain brake is engaged	Disengage the chain brake

THE SAW CHAIN ROTATES, BUT DOES NOT CUT

The saw chain is dull	Sharpen or replace the saw chain
The saw chain is on backwards	Check and correct the saw chain direction

If further assistance is required, contact an authorized service center.

WARRANTY

MANUFACTURER'S LIMITED WARRANTY FOR:

BILT HARD

The limited warranty set forth below is given by BILT HARD with respect to new merchandise purchased and used in the United States, its possessions and territories.

BILT HARD warrants this product against defects in material and workmanship for a period of three (3) years commencing on the date of original purchase and will, at its option, repair or replace, free of charge, any part found to be defective in material or workmanship. This limited warranty shall only apply if this product has been operated and maintained in accordance with the Operator's Manual furnished with the product, and has not been subject to misuse, abuse, commercial use, neglect, accident, improper maintenance, alteration, vandalism, theft, fire, water or damage because of other peril or natural disaster. Damage resulting from the installation or use of any accessory or attachment not approved by BILT HARD for use with the product(s) covered by this manual will void your warranty as to any resulting damage. This warranty is limited to ninety (90) days from the date of original retail purchase for any BILT HARD product that is used for rental or commercial purposes, or any other income-producing purpose.

HOW TO OBTAIN SERVICE: Warranty service is available, call (888)680-2849.

This limited warranty does not provide coverage in the following cases:

- A. Tune-ups - Spark Plugs, Carburetor Adjustments, Filters
- B. Wear items - Bump Knobs, Outer Spools, Cutting Line, Inner Reels, Starter Pulley, Starter Ropes, Drive Belts, Saw Chains, Guide Bars, Cultivator Tines, Blades.

BILT HARD reserves the right to change or improve the design of any BILT HARD Product without assuming any obligation to modify any product previously manufactured.

No implied warranty, including any implied warranty of merchantability or fitness for a particular purpose, applies after the applicable period of express written warranty above as to the parts as identified. No other express warranty or guaranty, whether written or oral, except as mentioned above, given by any person or entity, including a dealer or retailer, with respect to any product shall bind BILT HARD. During the period of the Warranty, the exclusive remedy is repair or replacement of the product as set forth above. (Some states do not allow limitations on how long an implied warranty lasts, so the above limitation may not apply to you.)

The provisions as set forth in this Warranty provide the sole and exclusive remedy arising from the sales. BILT HARD shall not be liable for incidental or consequential loss or damages including, without limitation, expenses incurred for substitute or replacement lawn care services, for transportation or for related expenses, or for rental expenses to temporarily replace a warranted product. (Some states do not allow limitations on how long an implied warranty lasts, so the above limitation may not apply to you.)

In no event shall recovery of any kind be greater than the amount of the purchase price of the product sold. Alteration of the safety features of the product shall void this Warranty. You assume the risk and liability for loss, damage, or injury to you and your property and/or to others and their property arising out of the use or misuse or inability to use the product.

This limited warranty shall not extend to anyone other than the original purchaser, original lessee or the person for whom it was purchased as a gift.

How State Law Relates to this Warranty: This warranty gives you specific legal rights, and you may also have other rights which vary from state to state.