

MINI EXCAVATOR **SWE 35UF**

Engine Power: **24.4HP/18.2 kW**

Machine Weight: **8489 lbs/3 850 kg**





# OUR STANDARD FEATURES

## Presenting the SWE 35UF

I take great pride in introducing the SWE 35UF zero-tail mini excavator, which has been specifically designed and certified for European market requirements. This 3.85t mini excavator can do it all, either in professional hands or by occasional users. The machine's modern styling visualizes its durability and efficacy and indicates how easy the machine is to transport, operate and maintain.

This top-of-the-line mini excavator offers excellent performance, comfortable and safe operation, and convenient maintenance. The SWE 35UF is the perfect size for a variety of agricultural, civil engineering, construction, or landscaping projects. Our SWE 35UF is one of the preferred machines of contractors and municipalities. At the same time, the SWE 35UF's power, efficiency, versatility and great design make it one of our best sellers in Europe.

A product of our company's innovative DNA, the SWE 35UF creates value for our customers and improves the quality of life. In just 20 years, Sunward has grown to become one of the world's top 50 construction machinery manufacturers and top 20 excavator companies. Today, our products are exported to more than 100 countries worldwide.

Thank you for sharing our pride!

*Professor He*  
Professor He

## Main features

### RELIABLE, POWERFUL AND DURABLE

We never compromise on reliability. And the SWE 35UF zero-tail (3.85t) is no exception – we know it will be used by professional companies as well as rented to occasional users.

So, just like our other machines, all key components come from the world's top premium brands. From the Kubota Stage V engine to the Japanese travelling motor, all is set for reliability, durability and enhanced performance. Sunward's unique hydraulic system enhances this 3.85t machine's performance by providing the most powerful bucket break-out on the market.

### VERSATILE AND OPTIMIZED

Because a +3.5t machine is essentially a multiple job site machine, it must be fit for all kinds of jobs and users' needs. The SWE 35UF has 3 separate functional lines – which means that Sunward provides the highest flexibility on the market as standard – to accommodate any working requirement and tool, including a tilt rotator.

### SAFE AND COMFORTABLE

Because we know that safety and comfort should go hand-in-hand, the SWE 35UF keeps you safe and provides every comfort in all working conditions. The fully EU-certified cab features FOPS and TOPS, from the reinforced undercarriage, the boom and arm reinforced frames, to the all-steel panels and cast-iron wrap around. And thanks to the full visibility provided by 4 perfectly positioned LED work lights as a standard feature, you stay safe, day and night.

### EASY TO MAINTAIN AND SERVICE

All Sunward machines are designed, prototyped and then disassembled – in the spirit of reverse engineering – simply to test how easy they are to be serviced and maintained. And they are! From ground-level access to service components, to the availability of parts – maintaining the SWE 35UF zero-tail is easy and simple. So, it's no surprise that an operator only needs to try out our machines to be thoroughly convinced!



# ARE OPTIONS FOR OTHERS





# Reliable, Powerful and Durable

## All key components are carefully selected

We chose the powerful Kubota D1703 engine for several good reasons. This engine is a vertical, water-cooled, 4-cycle diesel engine with a capacity of 24.4HP at 2 200 rpm. Featuring a built-in solenoid, low fan position and single side serviceability, the Kubota D1703 offers powerful performance, exceptional reliability and a long service life to meet a wide range of applications. The perfect fit for our reliable and versatile SWE 35UF.

Moreover, because the hydraulics are often regarded as the heart of the machine, Sunward sources exclusively from the highest references in the market. For the SWE 35UF, we selected HENGLI to be our main supplier for the hydraulic pump, and KYB for the traveling and swing motors. All these pumps and components for construction machinery are efficient, reliable, and space-saving. So, it's no coincidence that Sunward selected them to contribute to the SWE 35UF's reliability.



## Premium brand critical components

### KUBOTA

Stage V engine



### HENGLI

Cartridge  
Valves and joystick



### HENGLI

Main pump



### KYB

Traveling motor



### KYB

Swing motor





Max. 4085.4 lbs

Max. 17'8"

## Best digging forces and long-reach capacity on the market

The SWE 35UF has exceptional digging forces – 7148.6 lbf (bucket) and 5064.7 lbf (arm) – easily rivaling all 3.5t excavator competitors on the market. And when it comes to its long-reach capacity, the SWE 35UF's boom cylinder design provides a ground reach of over 5.2 meters (17'3") and a digging reach that's over 5.3 meters (17'8") long – making this mini excavator the benchmark of its range.



## Protection plates for boom and dozer cylinders

When working in the field, an excavator's boom cylinders are particularly at risk of damage caused by flying stones. We've taken special care to protect the boom and dozer cylinders with covering plates, so that the operator can focus fully on his job and not worry about the machine's components. And when you rent your machine, you know it will come back in good shape, ready for many more hours on the job.

## SMOOTH OPERATIONS THANKS TO

### Safety valves

Safety valves prevent uncontrolled cylinder movements, especially during the load lifting work. And because reliability and performance are part of the package, the SWE 35UF is equipped with safety valves as a standard feature.

### Pilot traveling control

To continually enhance precise and controlled operations, all of our mini excavators provide pilot traveling control as a standard feature.



### Auto gear shifting during traveling

The SWE 35UF features auto high & low speed gear shifting for when the machine encounters an obstacle during high-speed traveling. To increase traction to get over the obstacle, the SWE 35UF shifts from high speed to low speed automatically. And then, after getting over the obstacle, the machine automatically returns to high-speed mode. This automatic gear shifting frees the operator from having to frequently flip the 2-speed switch.



# Versatile and Optimized

## Engineering and design produce optimal, versatile machines

In the spirit of Sunward's motto – 'Innovation Leads to Value' – all engineering and design are focused on generating optimal value for the machine's owner. So, our machines can be used in a large variety of working conditions and applications – exactly what you're looking for in a 3.85t mini excavator, especially with its zero-tail design.

## Well-equipped from the outset

This slightly over 3.5t machine has it all from the day it leaves the factory:

- Auto idle engine to save fuel and limit the engine's consumption.
- While other manufacturers usually use a flow throttle (because it's cheaper), we at Sunward opt for a Load Sensing (hydraulic) system, which provides better energy-saving possibilities.
- Safety valves for the boom cylinder for safer operations.
- Auto-shifting traveling motor for smooth operations and operator ease.
- TOPS & FOPS cab.
- Battery cut-off switch for safer operations and prolonged battery lifetime and power – which is especially appreciated in the cold weather of Scandinavian countries.
- 4 LED work lights as standard: 2 on the front of the cab, 1 on the left side of the boom, 1 on the back of the cab.



## A true zero-tail machine

All kinds of jobs can be executed with the true zero-tail SWE 35UF. The machine hugs the wall to deliver a precise and optimized job.

Ready to face any situation from Day 1 on the job site



## Full auxiliary lines as standard

Thanks to the full set of auxiliary hydraulic lines as standard, the SWE 35UF zero tail swing provides pressure control and flow for all types of attachment on any job site.

This results in no less than 3 separate auxiliary lines as standard (while the market provides 1 to 2 lines as standard), which are distributed as follows:

- 1 line at the front end of the arm (AUX1), which is used primarily for the hydraulic quick-hitch
- 1 line for greater flow to fulfill the requirements of a flow-demanding attachment, such as a breaker (AUX2)
- 1 line with lesser flow as an extra line for attachments that are equipped with 2 actuators (AUX3)

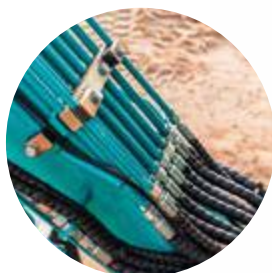

Extra protection for hoses /  
/ AUX 2 lines

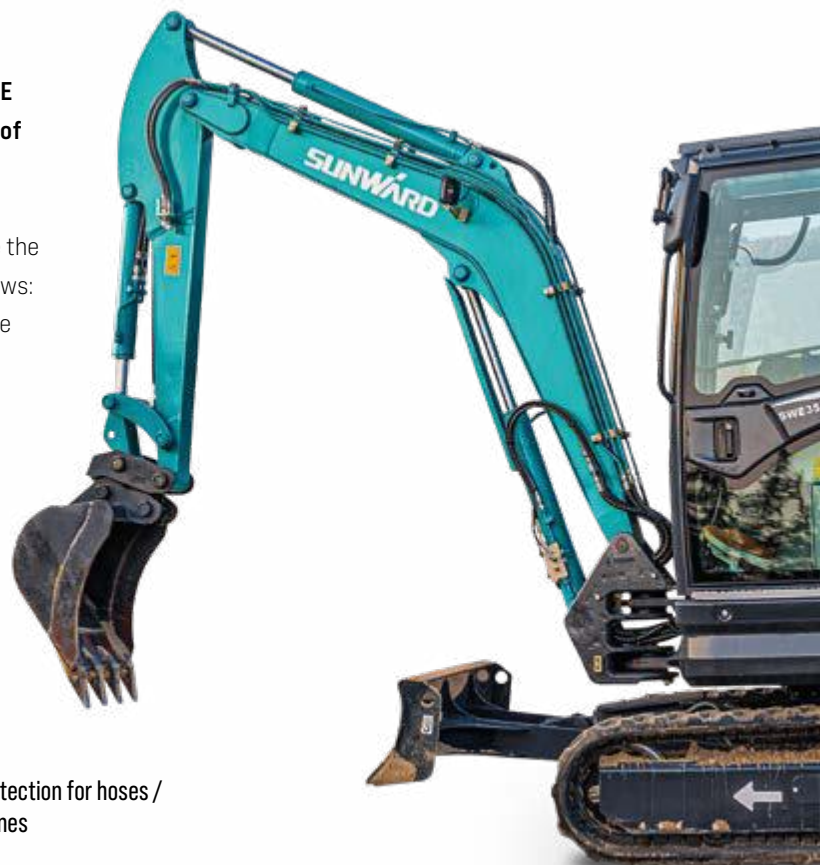



# Safe and Comfortable

On top of their EU certification, all Sunward machines on the European market are designed to meet European customer needs. Without compromising between comfort and safety.



## Safe & Comfy Cab

FOPS and TOPS cab tops are standard and among the first features to ensure a safe and comfortable job in all application environments.

The well-organized cab is clearly designed to keep operators comfortable and productive. The large entrance to the roomy cab welcomes operators of all sizes from everywhere in Europe. From the suspension seat and heating, to the adjustable arm rest and the radio with USB ports, the cab's features promote efficiency. The superior visibility through the large windows, and the clear layout of the controls, add to the great ease of operation. Finally, the safety pack – including fire extinguisher, safety hammer, safety belt and standard travelling alarm – contributes to overall peace of mind.



Suspension seat

Simple interface

**Large windows**  
for full visibility and thus safe work





Simple  
operation



### All-around visibility on bright and grey days

The cab's wide windows and slender frame, enhanced by mirrors on both sides, make it easy to operate with all-around awareness of the machine's environment. Plus, to keep working conditions safe in all kinds of weather, 24 hours a day, these mini excavators are equipped with 4 LED work lights as standard: 2 on the front of the cab, 1 on the left side of the boom, 1 on the back of the cab.

Extra top visibility  
and safety as standard



### Color monitoring touch screen

The easy-to-read 5.7" color monitoring touch screen – with centralized functions and simple interface for easy operation – makes all key information readily accessible: machine status, engine rpm and temperature, fuel level, machine hours, oil indicators and charging indications.



# Easy to Maintain and Service

## All service points are centralized and easy to access

To reduce maintenance time and cost for the SWE 35UF, the covers at the rear and on the side provide direct access to the service points. The standard service points – for fuel, oil and air filters – are directly accessed via the cover at the rear.

### 01 FUEL FILTER



### 02 ENGINE OIL FILTER



### 03 ELECTRIC FUEL FEED PUMP



### 04 FUEL-WATER SEPARATOR



### 05 ENGINE OIL TANK CAP

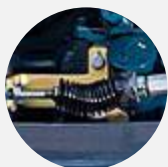

## Did you know?

Operators and maintenance teams can enjoy a machine that has been designed, prototyped and then disassembled – in the spirit of **reverse engineering** – to facilitate all service and maintenance operations.



So, with very easy access to the fuel tank and centralized grease fittings, these mini excavators are as easy to maintain as they are to operate.

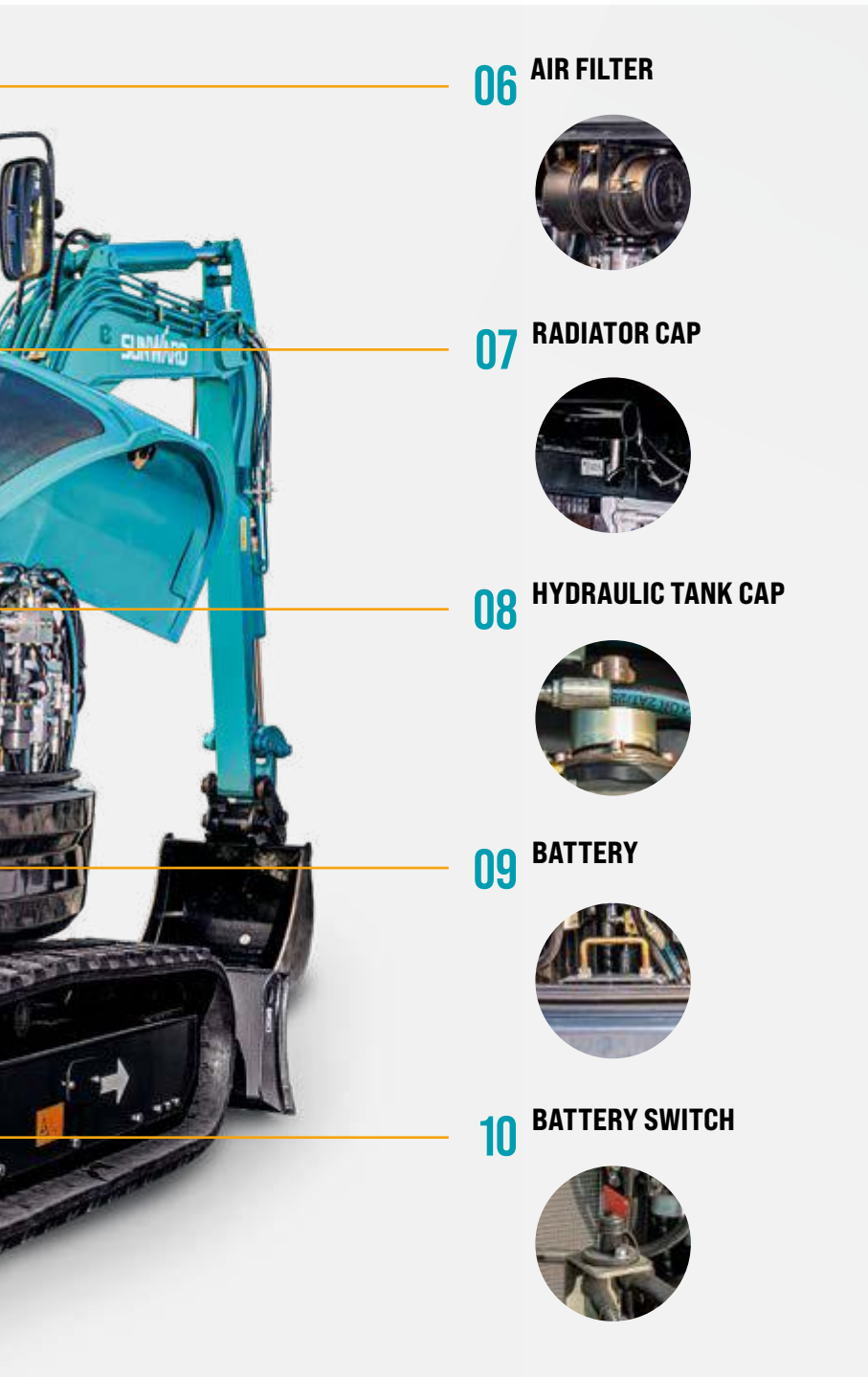

## 06 AIR FILTER



## 07 RADIATOR CAP

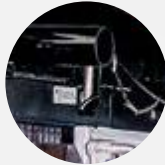

## 08 HYDRAULIC TANK CAP



## 09 BATTERY



## 10 BATTERY SWITCH

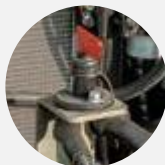

UP TO  
**3 YEARS**  
OF WARRANTY  
STANDARD FOR ALL  
SUNWARD PRODUCTS

## Best Value for Money from A to Z

The expert design of the SWE 35UF includes a well-thought-out selection of components that streamline operation and maintenance. Our design choices result in machines that provide so many standard features, premium-brand key components, and capabilities at a good price.

Furthermore, Sunward's own genuine spare parts are economical as well. And all this best value for money is offered with flexible, low-rate finance packages and crowned by a 3-year standard manufacturer's warranty.



# Direct Support within Canada



## Readily available machines & parts

Readily available machines & parts  
From its Dallas headquarters, Sunward Canada can ensure rapid delivery of machines and spare parts everywhere in Canada. Machines can be delivered within a few weeks from local dealers, and Sunward machine operators benefit from quick and easy access to the large Dealers' Parts Warehouse (DPW) distribution center in Dallas.



**SUNWARD GENUINE PARTS ARE BUILT, TESTED, AND PRODUCED TO PROVIDE OPTIMUM PERFORMANCE, DURABILITY, AND SAFETY.**

## Dealers all over Canada

Dealers are at the heart of Sunward's passion for continuous improvement. Our dealers' knowledge is a real asset – and because they serve local market needs, their feedback enhances our engineering and design innovations. Sunward's innovations create value – for machine operators and, ultimately, for our dealers.





## EQUIPMENT

The standard and optional equipment varies from country to country. For more information, please contact us.

		STANDARD EQUIPMENT	OPTIONAL EQUIPMENT
CAB	Digital touchscreen monitor	•	
	AM/FM radio with USB port	•	
	Cup holder	•	
	Seat with shock absorber	•	
	Air conditioning	•	
	Engine safety start system	•	
	Safety belt	•	
	TOPS/FOPS cab or canopy	•	
	Windscreen washer and wiper	•	
	Left & right rearview mirrors	•	
	Cigarette lighter	•	
	Keypad anti-theft system		•
	Right proportional joystick	•	
	Dual proportional Joystick		•
FRONT WORKING DEVICES	300 mm bucket		•
	520 mm bucket		•
	1200 mm bucket		•
	1550 mm arm	•	
	Breaker		•
	Boom cylinder protection plate	•	
	Blade protection plate	•	
	Kit safety valve (protections + arm + overload box + Ring on bucket link)		•
	Boom safety valve	•	
	Kit safety valve Blade		•
TRACKS	300 mm rubber track	•	
	300 mm steel track		•
ENGINE	Oil filter	•	
	Fuel filter	•	
	Fuel-water separator	•	
	Air filter	•	
	Radiator	•	
	Alternator	•	
	Battery cut-off switch	•	
	Engine Auto idle system	•	
	Coolant expansion tank	•	
	Electronic fuel pump	•	
HYDRAULIC SYSTEM	Muffler	•	
	Hydraulic pilot control	•	
	Parking-upon-swing brake	•	
	Parking-upon-traveling brake	•	
	Dual-speed traveling system	•	
	Auto-shift travel system	•	
	1st Auxiliary hydraulic breaker circuit line to arm end (2 pipes)	•	
	2nd Auxiliary hydraulic circuit line to arm end (2 pipes)	•	
	3rd hydraulic quick hitch line to arm end (2 pipes)	•	
	Oil return pipe (1 pipe)	•	
	Auto-lubrication system		•
Hydraulic QH line Safety kit (only available with all hydraulic QH)		•	
LIGHTS	1 Boom LED working light	•	
	2 Front cab LED working lights	•	
	Beacon light with magnetic base	•	
	Warning beacon light for canopy version	•	
	Rear LED working light	•	
OTHER	Additional counter weight		•
	Smart fleet system		•



## TECHNICAL PARAMETERS

TYPE OF CAB			Cab/canopy
BUCKET CAPACITY		0.14 yd <sup>3</sup>	0.11 m <sup>3</sup>
BUCKET WIDTH, STD.		1'8.5"	520 mm
MACHINE WEIGHT		8269 - 8489 lbs	3 750 – 3 850 kg
DIMENSIONS	Overall dimension (L × W × H)	16' × 5'7" × 8'5"	4 890 × 1700 × 2 555 mm
	Ground clearance	10.5"	270 mm
ENGINE	Brand		KUBOTA
	Model		D1703-E4B-SWD-1
	Emission rating		EU Stage V
	Displacement	0.43 gal	1.647 L
	Output	24.4/2200 HP/rpm	18.2/2 200 kW/rpm
TRACK	Type		Rubber crawler
	Rubber shoe width	11.7"	300 mm
UNDERCARRIAGE	Track length	7'1"	2 163 mm
	Length to center of rollers	5'6"	1 670 mm
	Length to center of track	4'7"	1 400 mm
	Traveling speed (High/Low)	2.6/1.4 mph	4.2/2.3 km/h
	Gradeability		30 deg
SWING SPEED			9.5 rpm
GROUND PRESSURE		4.7 psi	32.3 kpa
DOZER SIZE	Width	5'7"	1700 mm
	Height	1'2"	366 mm
	Lifting capacity (Height/Depth)	1'1.2"/1'2.8"	337/376 mm
HYDRAULIC PUMPS	Type		1 variable piston pump
	Flow rate	23.2 gal/min	88 L/min
	Hydraulic pressure	3553.5 psi	24.5 MPa
SWING MOTOR			Piston motor
TRAVEL MOTOR			2-speed piston motor
FUEL TANK CAPACITY		10.6 gal	40 L
HYDRAULIC OIL TANK CAPACITY		10.8 gal	41 L

## DIMENSIONS

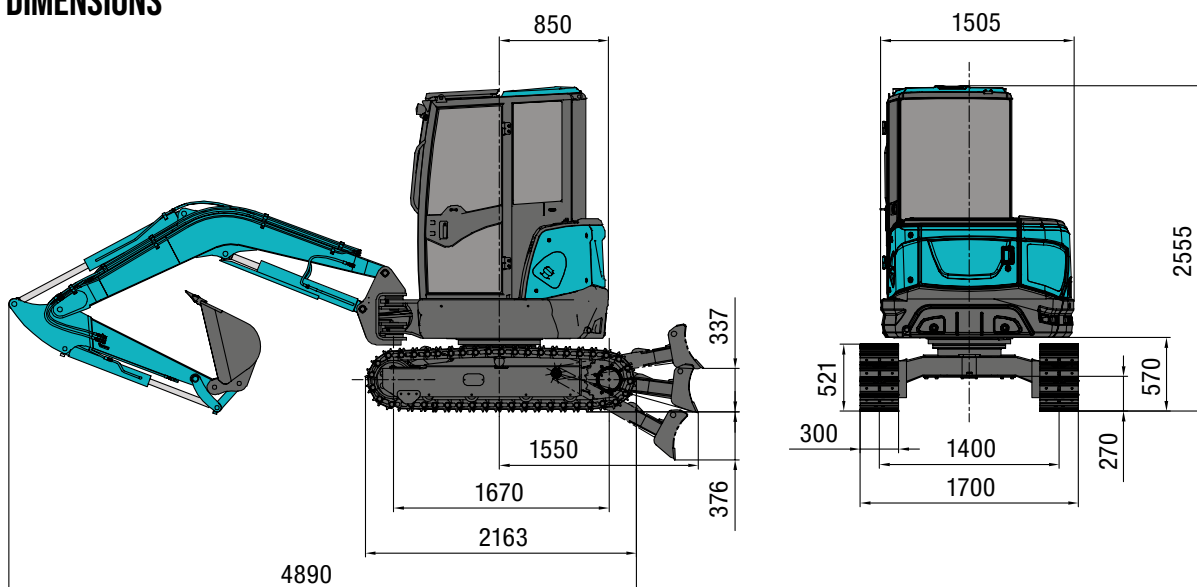

## WORKING RANGE

WORKING RANGES	Max. cutting height	16'2"	4 925 mm
	Max loading height	11'2"	3 400 mm
	Max digging depth	10'3"	3 120 mm
	Max reach on the ground	17'3"	5 260 mm
	Max digging reach	17'8"	5 390 mm
	Boom swing angle (Left/Right)	72/44°	
	Front swing radius	7'5"	2 265 mm
	Tail swing radius	2'9"	850 mm
	Max digging force (Arm)	4451 lbf	19.8 Kn
	Max digging force (Bucket)	7148.6 lbf	31.8 kN

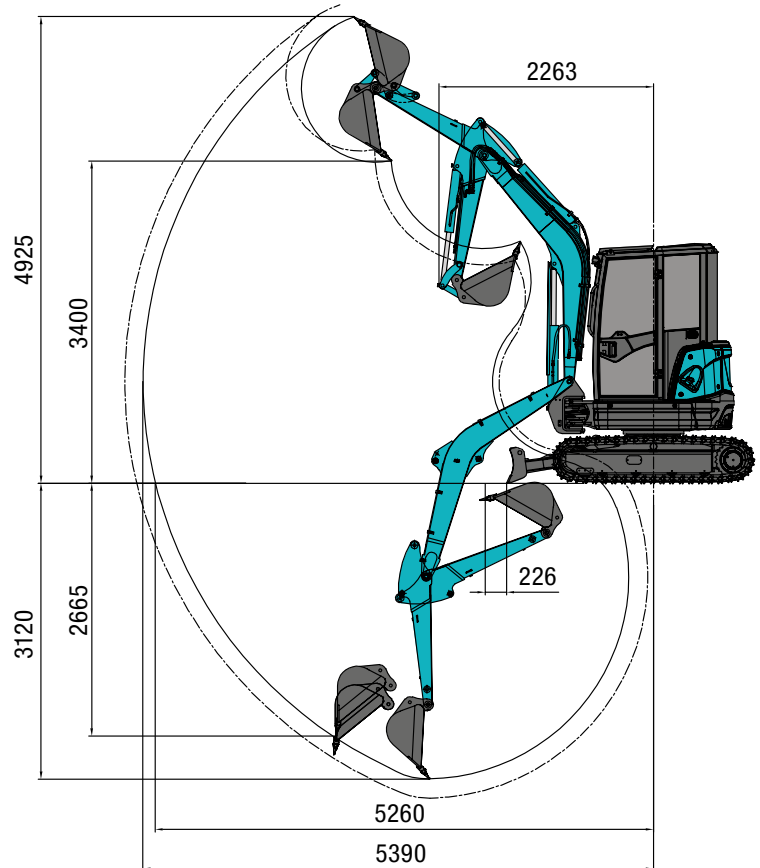

## LIFTING CAPACITY

Lift Point Height (ft/m)	Lift Point radius (MAX)		Lift Point radius (13ft/4.0 m)		Lift Point radius (11.5ft/3.5 m)		Lift Point Radius(9.8ft/3.0m)		Lift Point Radius(8.2ft/2.5m)	
	Over-front (lbs/kg)	Over-side (lbs/kg)	Over-front (lbs/kg)	Over-side (lbs/kg)	Over-front (lbs/kg)	Over-side (lbs/kg)	Over-front (lbs/kg)	Over-side (lbs/kg)	Over-front (lbs/kg)	Over-side (lbs/kg)
4.0	-	-	-	-	-	-	-	-	-	-
9.8	3.0	1515.5* 687.3*	843.4 382.5	-	-	-	-	-	-	-
6.5	2.0	1707.3* 774.3*	645 292.5	1803.2* 817.8*	843.4 382.5	1937.5* 878.7*	1041.9 472.5	2244.5* 1017.9*	1422.2 645.0	2704.9 1226.7* 1868.7 847.5
3.3	1.0	1784* 809.1*	578.8 262.5	2110.2* 957*	744.2 337.5	2378.8* 1078.8*	942.6 427.5	2992.6* 1357.2*	1223.8 555.0	4086.1* 1853.1* 1670.3 757.5
0	-	-	-	-	-	-	-	-	-	-

Notes:

1. Load with \* is limited by hydraulic capacity and based on ISO 10567. Rated loads do not exceed 87% of hydraulic capacity.
2. Load without \* is limited by tipping load and based on ISO 10567. Rated loads do not exceed 75% of tipping capacity.
3. The excavator bucket, hook, sling and other lifting accessories are not included in this table.

