

MINI EXCAVATORS

# SWE 25UF & SWE 25F

Engine Power: **19.6HP/14.6kw**

Machine Weight: **2650kg/5843.3lbs** (SWE 25UF)

| **5821lbs/2640kg** (SWE 25F)



# OUR STANDARD FEATURES

## Presenting the SWE 25UF and SWE 25F

I take great pride in introducing two jewels – the **SWE 25F** and its zero-tail version the **SWE 25UF mini excavators**. Both have been specifically designed and certified for European market requirements. These 2.64t & 2.65t mini-excavators can do it all, either in professional hands or by occasional users. Both machines are designed to be durable and efficient and indicate how easy they are to transport, operate and maintain.

These top-of-the-line mini-excavators offer excellent performance, comfortable and safe operation, and convenient maintenance. The SWE 25F is the perfect size for a variety of commercial and residential construction projects, such as trenching, minor landscaping or building pads and foundations. At the same time, the SWE 25UF's power, efficiency, versatility and great zero-tail design is perfect for work on sideways or urban jobsites, or more generally in confined spaces, making it one of our bestsellers in Europe.

Products of our company's innovative DNA, the SWE 25F and SWE 25UF create value for our customers and improve the quality of life. In just 20 years, Sunward has grown to become one of the world's top 50 construction machinery manufacturers and top 20 excavator companies. Today, our products are exported to more than 100 countries worldwide.

Thank you for sharing our pride!

*Professor He*

Professor He

## Main features

### RELIABLE, POWERFUL AND DURABLE

We never compromise on reliability. And the SWE 25F (2.64t) and its zero-tail version SWE 25UF (2.65t) are no exception – we know they will be used by professional companies as well as rented to occasional users. So, just like our other machines, all key components come from the world's top premium brands. From the Yanmar Stage V engine to the Japanese-made hydraulic system, all is set for reliability, durability and enhanced performance. Sunward's unique hydraulic system enhances these 2.64t/2.65t machines' performance by providing one of the more powerful bucket break-outs on the market.

### VERSATILE AND OPTIMIZED

Because a +2.5 t machine is essentially a multiple job site machine, it must be fit for all kinds of jobs and users' needs. The SWE 25F & SWE 25UF have 3 separate functional lines – which means that Sunward provides the highest flexibility on the market as standard – to accommodate any working requirement and tool, including a tiltrotator.

### SAFE AND COMFORTABLE

Because we know that safety and comfort should go hand-in-hand, the SWE 25F & SWE 25UF keep you safe and provide every comfort in all working conditions. The fully EU-certified cab features FOPS and TOPS, from the reinforced undercarriage and the boom and arm reinforced frames, to the all-steel panels and cast-iron wrap around. And thanks to the full visibility provided by 3 perfectly positioned LED work lights (+1 extra at the back for the SWE 25F) as a standard feature, you stay safe, day and night.

### EASY TO MAINTAIN AND SERVICE

All Sunward machines are designed, prototyped and then disassembled – in the spirit of reverse engineering – simply to test how easy they are to be serviced and maintained. And they are! From ground-level access, to service components, to the availability of parts – maintaining the SWE 25F and its zero-tail sister the SWE 25UF is easy and simple. So, it's no surprise that an operator only needs to try out our machines to be thoroughly convinced!

# ARE OPTIONS FOR OTHERS



# Reliable, Powerful and Durable

## All key components are carefully selected

We chose the powerful Yanmar 3 TNV 80F engine for a number of good reasons. This engine uses indirect injection and it features low fuel consumption, low noise and vibration levels, and high-altitude performance control. This 19 hp (19.6HP) industrial diesel engine is both EPA Final Tier 4 and EU Stage V compliant, and its compact design means it can fulfill a variety of roles. The perfect fit for our reliable and versatile SWE 25F and SWE 25UF.

Because the hydraulics are often regarded as the heart of the machine, Sunward sources exclusively from the highest references in the market. For our 2 new mini excavators, we selected Japanese premium brands to be our main suppliers for the hydraulic pump, traveling and swing motor. NACHI and Kayaba pumps and components are efficient, reliable, and space-saving. So, it's no coincidence that Sunward selected them to contribute to the SWE 25F and 25UF's reliability.

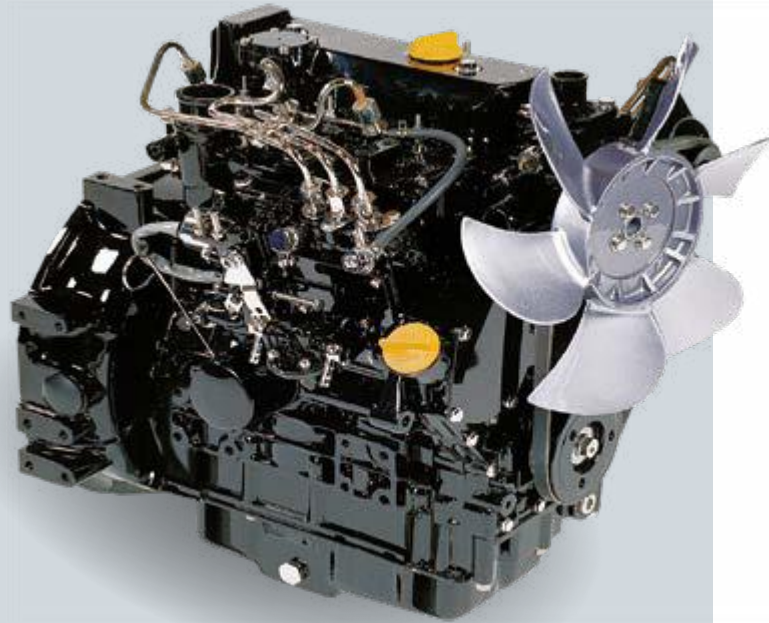

## Premium brand critical components

25F	<p><b>YANMAR</b></p> <p>Stage V engine</p> 	<p><b>HENGLI</b></p> <p>Cartridge Valves and joystick</p> 	<p><b>HENGLI</b></p> <p>Main pump</p> 	<p><b>KYB/EATON</b></p> <p>Traveling motor</p> 	<p><b>KYB</b></p> <p>Swing motor</p> 
25UF	<p><b>YANMAR</b></p> <p>Stage V engine</p> 	<p><b>KYB/HENGLI</b></p> <p>Cartridge Valves and joystick</p> 	<p><b>NACHI/HENGLI</b></p> <p>Main pump</p> 	<p><b>KYB/EATON</b></p> <p>Traveling motor</p> 	<p><b>NACHI</b></p> <p>Swing motor</p> 



25F - Max. 15' 10"



25UF - Max. 15' 8"

## Best digging forces and long-reach capacity on the market

The SWE 25F and SWE 25UF have exceptional digging forces – 24 kN (bucket) and 14 kN (arm) – easily rivaling any 2.5t excavator competitors on the market. And when it comes to their long-reach capacity, the SWE 25F's boom cylinder design provides a maximum reach of over 4.6 meters (15' 10"), and the zero-tail SWE 25UF's boom cylinder provides a digging reach that's over 4.7 meters (15' 8") long – making these 2 mini excavators the benchmark of their range.

## Protection plates for boom and dozer cylinders

When working in the field, an excavator's boom cylinders are particularly at risk of damage caused by flying stones. We've taken special care to protect the boom and dozer cylinders with covering plates, so that the operator can focus fully on his job and not worry about the machine's components. And when you rent your machine, you know it will come back in good shape, ready for many more hours on the job.



## SMOOTH OPERATIONS THANKS TO

### Auto gear shifting during traveling

If the SWE 25F or SWE 25UF encounters an obstacle during high-speed traveling, the machines feature auto high & low speed gear shifting. To increase traction to get over the obstacle, the SWE 25F and SWE 25UF shift from high speed to low speed automatically. And then, after getting over the obstacle, the machines automatically return to high-speed mode. This automatic gear shifting frees the operator from having to frequently flip the 2-speed switch.

### Pilot traveling control

To continually enhance precise and controlled operations, all of our 2.5t mini excavators provide pilot traveling control as a standard feature.

# Versatile and Optimized

## Engineering and design produce optimal, versatile machines

In the spirit of Sunward's motto – 'Innovation Leads to Value' – all engineering and design are focused on generating optimal value for the machine's owner. So, our machines can be used in a large variety of working conditions and applications – exactly what you're looking for in a 2.5t mini excavator.

### Well-equipped from the outset

This slightly over 2.5t machine is very well equipped from the day it leaves the factory:

- Double Acting Hydraulic Circuit
- Factory-fitted Hydraulic Quick Hitch
- LinesFactory-fitted Hammer & Rotation Line
- Factory-fitted Case Drain Line
- Factory-fitted One hydraulic pilot control with double contact switch
- Factory-fitted Tiltrotator Configured Joystick Controls (tiltrotator of your choice – Engcon, Steelwrist or Rototilt)



Ready to face any situation from Day 1 on the job site



### Full auxiliary lines as standard

Thanks to the complete auxiliary settings built in as standard, the SWE 25F and the zero-tail SWE 25UF provide fully adjustable pressure and flow monitoring for all types of attachments on any job site.

This results in no less than 3 separate auxiliary lines as standard (while the market provides 1 to 2 lines as standard), which are distributed as follows:

- 1 line at the bottom of the arm (AUX1), which is used primarily for the hydraulic quick-hitch
- 1 line for greater flow to fulfill the requirements of a flow-demanding attachment, such as a breaker (AUX2)
- 1 line with lesser flow as an extra line for attachments that are equipped with 2 actuators (AUX3)

Extra protection for hoses/AUX 2 lines





## Ready for all kinds of jobs

The SWE 25F and SWE 25UF enjoy full factory fitted equipment from Day 1, including all the features to welcome the most demanding attachment, i.e. the tiltrotator.



## Compact for easy transport

A 2.5t mini excavator's versatility starts with how well it is designed for transportation. The SWE 25F and SWE 25UF do more than simply align with the EU's transportation regulations – truly compact (4' 11" width) and lightweight (5821.2–5843.3lbs), these machines allow easy, safe and secure transport. With automatic slew lock and 4 easily accessed tie-down points on the upper frame, the machines can be safely transported on a small trailer with up to 3 buckets and a hydraulic breaker.



Compact and neat – easy to transport to any job site

# Safe and Comfortable

On top of their EU certification, all Sunward machines on the European market are designed to meet European customer needs. Without compromising between comfort and safety.



Suspension seat

Simple interface

## Safe & Comfy Cab

FOPS and TOPS cab tops are standard and among the first features to ensure a safe and comfortable job in all application environments.

The well-organized cab is clearly designed to keep operators comfortable and productive. The large entrance to the roomy cab welcomes operators of all sizes from everywhere in Europe. From the suspension seat and heating, to the adjustable arm rest and the radio with USB ports, the cab's features promote efficiency. The superior visibility through the large windows, and the clear layout of the controls, add to the great ease of operation. Finally, the safety pack – including fire extinguisher, safety hammer, and safety belt – contributes to overall peace of mind.



Large windows  
for full visibility and thus safe work





Simple  
operation

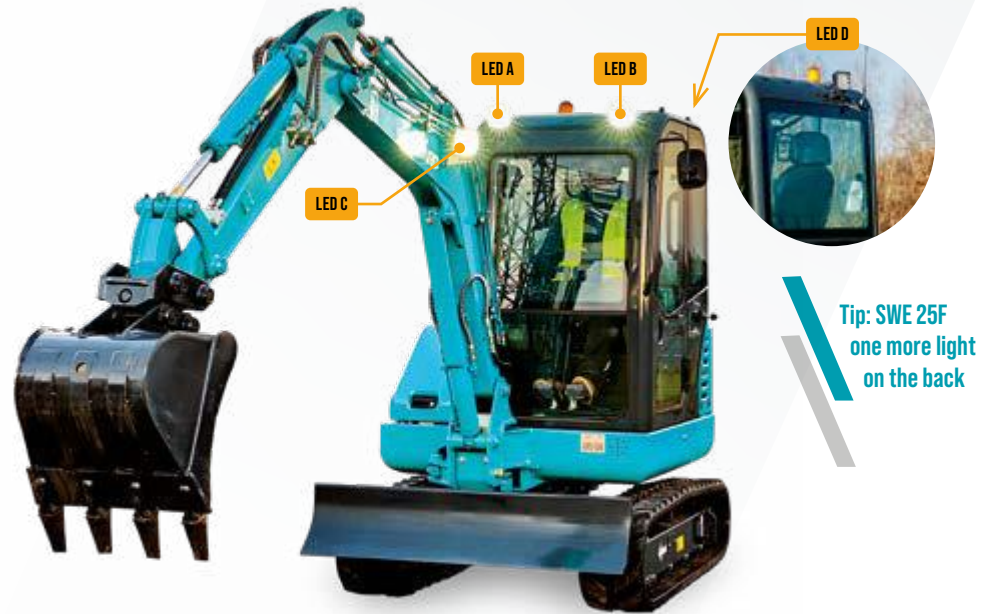

Tip: SWE 25F  
one more light  
on the back



Extra rear visibility and safety as standard

## All-around visibility on bright and grey days

The cab's wide windows and slender frame, enhanced by mirrors on both sides, make it easy to operate with all-around awareness of the machine's environment. Plus, to keep working conditions safe in all kinds of weather, 24 hours a day, these mini excavators are equipped with up to 4 LED work lights as standard: 2 on the front of the cab, 1 on the left side of the boom, and 1 on the back (SWE 25F only).



## Color monitoring digital and analogue combined display

The easy-to-read 5.7" color monitoring digital and analogue combined display – with centralized functions and simple interface for easy operation – makes all key information readily accessible: machine status, engine rpm and temperature, fuel level, machine hours, oil indicators and charging indications.

# Easy to Maintain and Service

# 25F

## Large space for all service points

The covers at the rear and on the side provide direct access to the service points – giving the technician very easy access to the fuel tank and centralized grease fittings and lots of room in which to work. The result: faster maintenance and lower cost.



**01** FUEL & HYDRAULIC TANK AND BATTERY



**03** EXPANSION TANK



**05** PRIMARY FUEL FILTER



**07** MAIN CONTROL VALVE



### Did you know?

Operators and maintenance teams can enjoy a machine that has been designed, prototyped and then disassembled – in the spirit of reverse engineering – to facilitate all service and maintenance operations.

UP TO  
**3 YEARS**  
OF WARRANTY  
STANDARD FOR ALL  
SUNWARD PRODUCTS

# 25UF

## Centralized service points

To reduce maintenance time and cost, the cover at the rear provides direct access to the service points. With very easy access to the fuel tank and centralized grease fittings, the SWE 25UF is as easy to maintain as it is to operate.



**02** AIR FILTER



**04** PILOT FILTER



**06** INTERFACE FOR MEASUREMENT



**Best Value for Money from A to Z** The expert design of the SWE 25F and SWE 25UF includes a well-thought-out selection of components that streamline operation and maintenance. Our design choices result in machines that provide so many standard features, premium-brand key components, and capabilities... at a good price. And furthermore, Sunward's own genuine spare parts are economical as well. And all of this best value for money is offered with flexible, low-rate finance packages and crowned by a 3-year standard manufacturer's warranty.

# Direct Support within Canada



## Readily available machines & parts

Readily available machines & parts  
From its Dallas headquarters, Sunward Canada can ensure rapid delivery of machines and spare parts everywhere in Canada. Machines can be delivered within a few weeks from local dealers, and Sunward machine operators benefit from quick and easy access to the large Dealers' Parts Warehouse (DPW) distribution center in Dallas.



**SUNWARD GENUINE PARTS ARE BUILT, TESTED, AND PRODUCED TO PROVIDE OPTIMUM PERFORMANCE, DURABILITY, AND SAFETY.**

## Dealers all over Canada

Dealers are at the heart of Sunward's passion for continuous improvement. Our dealers' knowledge is a real asset – and because they serve local market needs, their feedback enhances our engineering and design innovations. Sunward's innovations create value – for machine operators and, ultimately, for our dealers.



## EQUIPMENT

The standard and optional equipment varies from country to country. For more information, please contact us.

		SWE 25F STANDARD EQUIPMENT	SWE 25F OPTIONAL EQUIPMENT	SWE 25UF STANDARD EQUIPMENT	SWE 25UF OPTIONAL EQUIPMENT
CAB	Digital and analogue combined display	●		●	
	AM/FM radio with usb port	●		●	
	Cup holder	●		●	
	Seat with shock absorber	●		●	
	Engine meso-position start system	●		●	
	Heater	●		●	
	Retractable harness	●		●	
	TOPS	●		●	
	FOPS	●		●	
	Windscreen washer and wiper	●		●	
	Rearview mirror	●		●	
	Cigarette lighter	●		●	
	Travel alarm	●		●	
	Right proportional joystick		●		●
	Dual proportional Joystick		●		●
FRONT WORKING DEVICES	300 mm bucket		●		●
	550 mm bucket		●		●
	1200 mm bucket		●		●
	1350 mm arm	●		●	
	Blade & Boom cylinder protection plate	●		●	
	Kit safety valve (Protections+Boom & Arm safety valve+Overload box+Ring on bucket link)		●		●
	Kit safety valve Blade		●		●
TRACKS	Breaker piping	●		●	
	300 mm rubber track 300 mm steel track	●	●	●	●
ENGINE	Oil filter	●		●	
	Fuel filter	●		●	
	Fuel-water separator	●		●	
	Air filter	●		●	
	Radiator	●		●	
	Alternator	●		●	
	Battery cut-off switch	●		●	
	Expansion tank	●		●	
	Electronic fuel pump	●		●	
	Muffler	●		●	
HYDRAULIC SYSTEM	Hydraulic pilot control	●		●	
	Parking-upon-swing brake	●		●	
	Parking-upon-traveling brake	●		●	
	Dual-speed traveling system	●		●	
	Auto-shift travel system	●		●	
	1st Auxiliary hydraulic breaker circuit line to arm end (2 pipes)	●		●	
	2nd Auxiliary hydraulic circuit line to arm end (2 pipes)	●		●	
	3rd hydraulic quick hitch line to arm end (2 pipes)	●		●	
	Oil return pipe (1 pipe)	●		●	
	Auto-lubrication system		●		●
	Hydraulic QH line Safety kit		●		●
LIGHTS	1 Boom LED working light	●		●	
	2 Front cab LED working lights	●		●	
	Warning beacon light for closed cab version	●		●	
	Warning beacon light for canopy version		●		●
	Rear LED working light	●		●	●
OTHERS	Additional counter weight				●
	Smart fleet system		●		●

# TECHNICAL PARAMETERS

		SWE 25F		SWE 25UF	
TYPE OF CAB		Cab/canopy		Cab/canopy	
BUCKET CAPACITY		0.104 yd <sup>3</sup>	0.08 m <sup>3</sup>	0.105 yd <sup>3</sup>	0.08 m <sup>3</sup>
BUCKET WIDTH, STD.		1'11"	580 mm	1'11"	580 mm
MACHINE WEIGHT		5821.2 lbs	2 640 kg	5843.3/5622.8 lbs	2 650/2 550 kg
DIMENSIONS	Overall dimension (L × W × H)	13'11"	4 262 × 1 500 × 2 400 mm	13'7"×4'11"×8'1"	4 140 × 1 500 × 2 455 mm
	Minimum ground clearance	11"	280 mm	12.09"	310 mm
ENGINE	Brand	YANMAR		YANMAR	
	Model	3TNV80F-SPSU		3TNV80F-SPSU	
	Emission rating	EU Stage V		EPA T4F	
	Displacement	0.334 gal	1.267 L	0.33 gal	1.267 L
	Output	19.5/2200 HP/rpm	14.6/2400 kW/rpm	19.6 /2400 HP/rpm	14.6/2400 kW/rpm
TRACK	Type	Rubber track/steel track		Rubber track/steel track	
	Rubber shoe width	11"	300 mm	11.7"	300 mm
UNDERCARRIAGE	Track length	6'6"	1990 mm	6' 6"	1990 mm
	Length to center of rollers	5'1"	1560 mm	5' 1"	1560 mm
	Length to center of track	3'11"	1200 mm	3' 11"	1200 mm
	Traveling speed (High/Low)	2.7/1.6 mph	4.4/2.6 km/h	2.55/1.43 mph	4.6/2.4 km/h
	Gradeability	30 deg		30 deg	
SWING SPEED		9(rpm)	9 rpm	9(rpm)	10 rpm
GROUND PRESSURE		3.62 psi	25 kpa	3.64 psi	25.1 kpa
DOZER SIZE	Width	4'11"	1500 mm	4' 11"	1500 mm
	Height	1'0.8"	325 mm	12.7"	325 mm
	Lifting capacity (Height/Depth)	4'0.9"/4'0.5"	330/320 mm	12'9"/12'5"=]]]]	330/320 mm
HYDRAULIC PUMPS	Type	1 variable piston pump		2 variable plunger pumps, 1 gear pump	
	Displacement	20.3 gal/min	1*77 L/min	2*7.6+5.1+1.7 gal/min	2*28.8+19.2+6.5 L/min
	Hydraulic pressure	3553.5 psi	24.5 Mpa	2*3408.44+2755.76psi	2*21.5+18 MPa
SWING MOTOR		piston motor		piston motor	
TRAVEL MOTOR		2-speed piston motor		piston motor	
FUEL TANK CAPACITY		7.9 gal	42.5 L	6.87 gal	26 L
HYDRAULIC OIL TANK CAPACITY		6.3 gal	30 L	6.34 gal	24 L

## DIMENSIONS

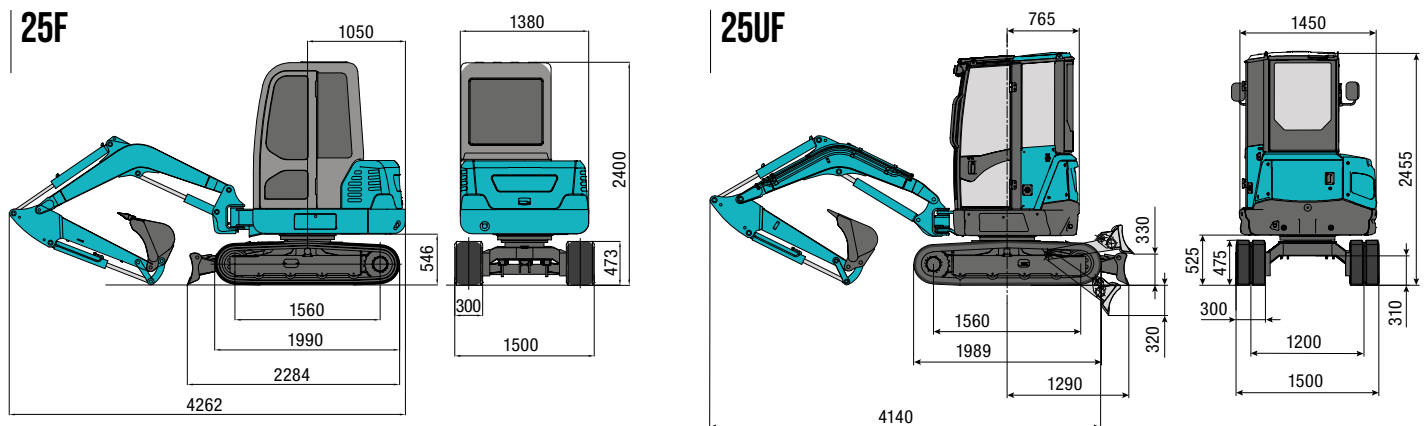

## WORKING RANGE

WORKING RANGES	SWE 25F			SWE 25UF	
	Max. cutting height	0.334 gal	4 445 mm	14' 3"	4 355 mm
	Max loading height	19.5/2200 HP/rpm	3 110 mm	9' 10"	3 010 mm
	Max digging depth	8'10"	2 705 mm	9' 4"	2 840 mm
	Max vertical wall digging depth	5'03"	2 475 mm	8' 6"	2 580 mm
	Max digging reach	15'10"	4 845 mm	15' 8"	4 775 mm
	Boom swing angle (Left/Right)	66/54 deg	66/54°	65/50 deg	65/50°
	Front swing radius	7'	2 143 mm	6' 6"	1 980 mm
	Tail swing radius	3'5"	1 050 mm	2'6"	765 mm
	Max digging force (Arm)	3147 lbf	14 kN	3147.2 lbf	14 kN
	Max digging force (Bucket)	5395 lbf	24 kN	5395.2 lbf	24 kN

### 25F

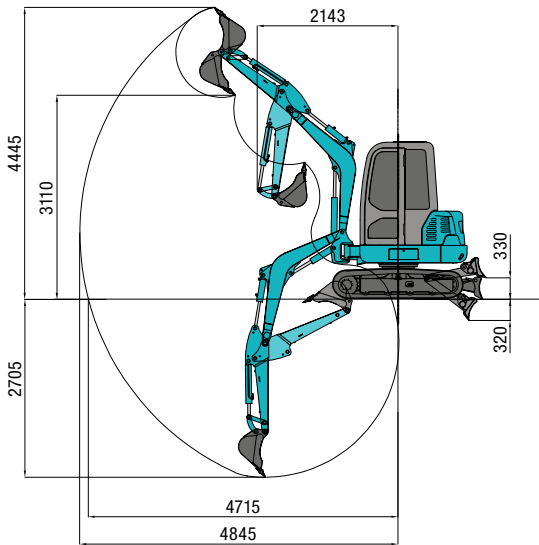

### 25UF

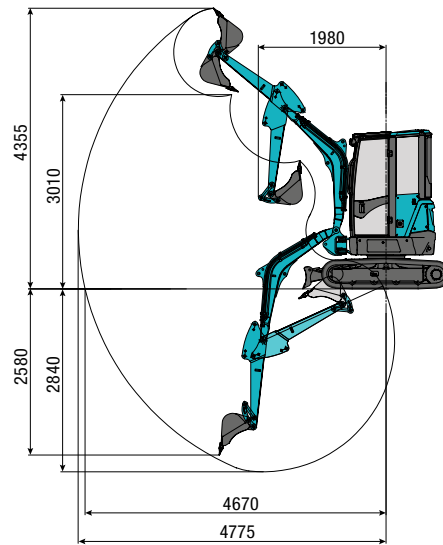

## LIFTING CAPACITY

Lift Point Height (ft/m)	SWE 25F						SWE 25UF						
	Lift Point radius (MAX)		Lift Point radius (9.8ft/3.0 m)		Lift Point radius (6.6ft/2.0 m)		Lift Point radius (MAX)		Lift Point radius (9'10"/3.0 m)		Lift Point radius (6'7"/2.0 m)		
	Over-front (lbs/kg)	Over-side (lbs/kg)	Over-front (lbs/kg)	Over-side (lbs/kg)	Over-front (lbs/kg)	Over-side (lbs/kg)	Over-front (lbs/kg)	Over-side (lbs/kg)	Over-front (lbs/kg)	Over-side (lbs/kg)	Over-front (lbs/kg)	Over-side (lbs/kg)	
8.2ft/2.5	959.2*/435.00*	736.5/334.00	853.3*/387.00*	815.9*/370.00*	-	-	9'10"/3.0	1266*/574.00*	878/398.00	-	-	-	-
3.3ft/1.0	1073.8*/487.00*	586.5/266.00	1342.8*/609.00*	983.4/446.00	-	-	4'11"/1.5	1314*/596.00*	562/255.00	1429*/648.00*	917/416.00	-	-
0ft/0	1159.8*/526.00*	586.5/266.00	1600.8*/726.00*	851.1/386.00	2849.3*/1292.20*	1413.4/641.00	0/0	1343*/609.00*	538/244.00	1899*/861.00*	761/345.00	2800*/1270.00*	1314/596.00
-3.3ft/-1.0	1256.9*/570.00*	694.6/315.00	1583.2*/718.00*	811.4/368.00	2216.0*/1005.00*	1265.7/574.00	-3'3"/-1.0	1391*/631.00*	646/293.00	1707*/774.00*	736/334.00	2428*/1101.00*	1091/495.00

Notes:

1. Load with \* is limited by hydraulic capacity and based on ISO 10567. Rated loads do not exceed 87% of hydraulic capacity.
2. Load without \* is limited by tipping load and based on ISO 10567. Rated loads do not exceed 75% of tipping capacity.
3. A: distance from center of rotation to perpendicular of weight; B: distance between bucket hinge pin and ground level.

### 25F

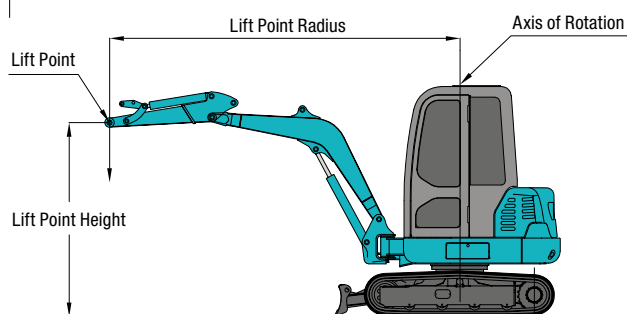

### 25UF

