



12v/24v 5.9 Cummins to 99-07 Super Duty, DIY Conversion Mount Kit

Kit Contents:



Note: The upper gussets and bushing mounts are interchangeable.

What you will need:

(2) 5/8" bolts, 3.75" length with lock nuts and washers

(2) Atrio Polyurethane Peterbilt 379 w/ CAT C15 & C11 Motor Mount Kit MM75-62370, or comparable bushings of your choice.

Step 1:

Grind a 3/16" chamfer into the shown locations.

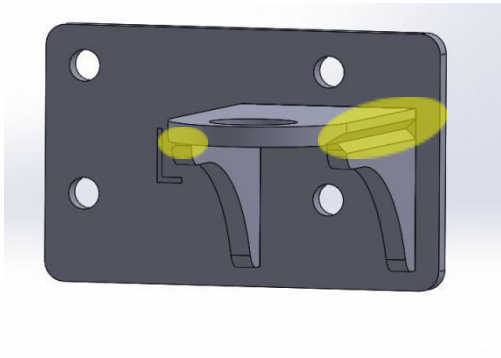

Step 2:

Place tabbed parts into the holes in the block plates, make sure everything is square, tack weld in place, then finish weld.



Step 3:

Test fit mounts and make any needed adjustments.

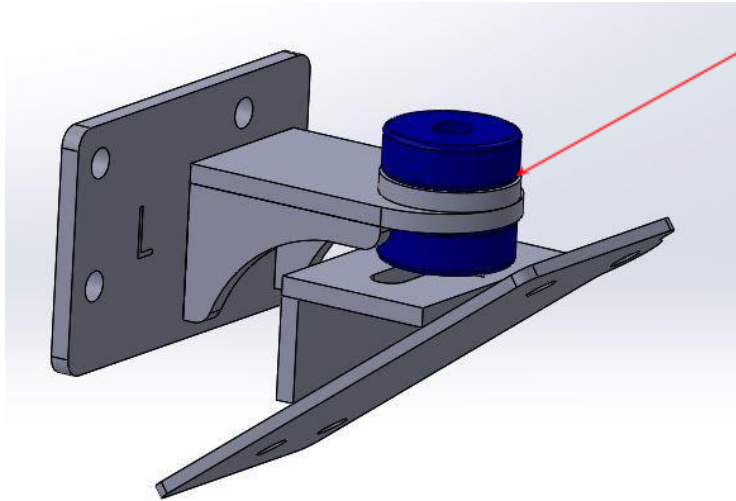

Note: Install bushing spacer on top of upper mount. If more clearance is desired between the oil pan and cross-member it can be placed underneath.

Step 4:

Finish Welding, Paint, and complete install.

