

CHALLENGER SERIES

BY PROFORMX™

REAR SEAT KIT

Fits Yamaha® G29 - Drive®

INSTALLATION INSTRUCTIONS FOR CHALLENGER SE AND CHALLENGER HD

SE Part

50-300-01 Stone

50-300-02 Black

HD Part

50-310-01 Stone

50-310-02 Black



All Steps and Illustrations showing Challenger HD. Follow same exact procedures for Challenger SE.



Seat Main Frame



Seat Back Brackets



Rear Cushion Set



Footrest



Footrest Brackets



Armrests



Bagwell Bracket

TOOLS NEEDED

- 17mm socket
- 13mm socket
- 12mm socket
- 10mm socket
- 17mm wrench
- 13mm wrench
- 10mm wrench
- #2 Phillips Tip Screwdriver
- 6mm Allen Wrench
- 5mm Allen Wrench
- 4mm Allen Wrench
- Cordless Drill (optional)

PARTS LIST

- Seat Main Frame
- Armrests
- Bagwell Bracket
- Seat Back Brackets
- Footrest
- Footrest Brackets
- Rear Cushion Set
- Hardware Packs 1-5
(not pictured)

Bolt Length Gauge

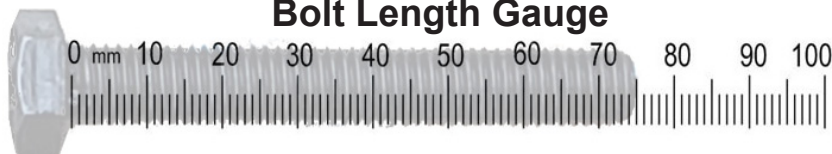

March 2020

STEP 1

Switch key to the OFF position and engage the Parking brake.

Place TOW/RUN switch to TOW.



DEM PARTS REMOVAL

STEP 2

Remove front and rear canopy hardware using a 13mm wrench and 5mm Allen head wrench.

Remove factory gutter hardware using a 4mm Allen head wrench.

Retain hardware, canopy, gutters, & gutter seals.

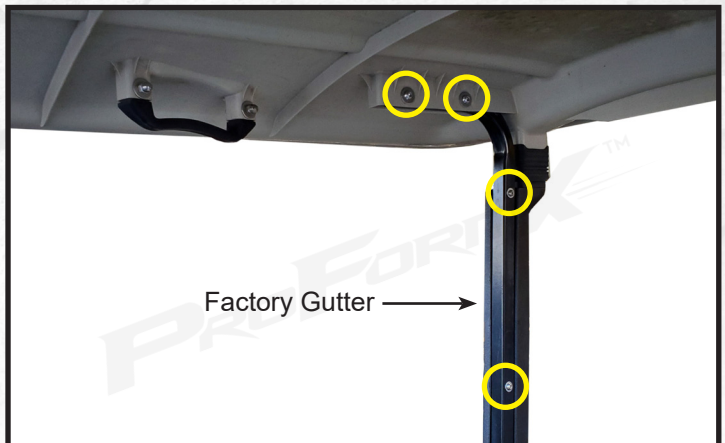

STEP 3

1) Using a 13mm socket remove rear struts from lean back as shown.

2) Then remove front seat cushion from sweater basket using a 10mm socket.

Retain all hardware for later steps.



STEP 4

Using a flat head screwdriver, remove factory rivets and motor cover, retain all for later steps.



STEP 5

Locate the two bolts on each side that hold the sweater basket to the frame and remove them using a 12mm socket.

Retain hardware, discard basket.



SEAT KIT INSTALL

STEP 6

Install new Seat Back Supports using the retained hardware from previous step. Do not fully tighten hardware until after next step.

Note: Mounting tabs should be facing to the outside and rear of cart.



STEP 7

Using hardware retained from STEP 3, attach front seat lean back cushion to Seat Back Supports with a 10mm socket.

You can now fully tighten the Seat Back Support hardware from STEP 6 to frame and reinstall motor cover.



STEP 8

Using a 10mm socket, remove and discard the two factory bagwell bolts shown.



STEP 9

Using the 6mm x 30mm bolts, washers, and lock washers from Pack 1, attach the Bagwell Bracket to the factory holes as shown. Do not fully tighten bolts yet.



STEP 10

Using two of the 10mm x 25mm bolts and washers from Pack 1, attach the Seat Frame to the Seat Back Supports as shown.

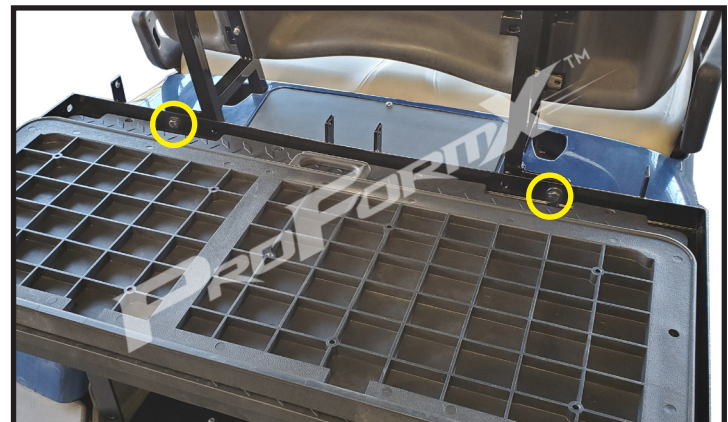

NOTE: Do NOT tighten any hardware until after STEP 13.

STEP 11

Use the remaining 10mm x 25mm bolts and washers from Pack 1 to secure the Bagwell Bracket to the Seat Frame cross bar as shown.

Note: The Bagwell Bracket uprights should be behind the cross bar (towards front).

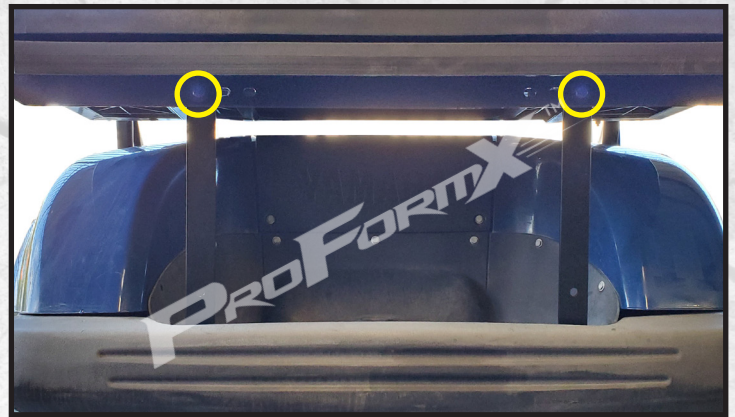

STEP 12

Using the 10mm x 50mm bolts and washers from Pack 2, secure Armrests to front of Seat Frame.

Attach Armrests to the rear of the Seat Frame using the 10mm x 50mm Pan Head bolts for the Challenger HD, use 10mm x 45mm Pan Head bolts for Challenger SE with washers and acorn nuts from Pack 2.

Note: The acorn nut must be on the outside of the seat frame as shown.

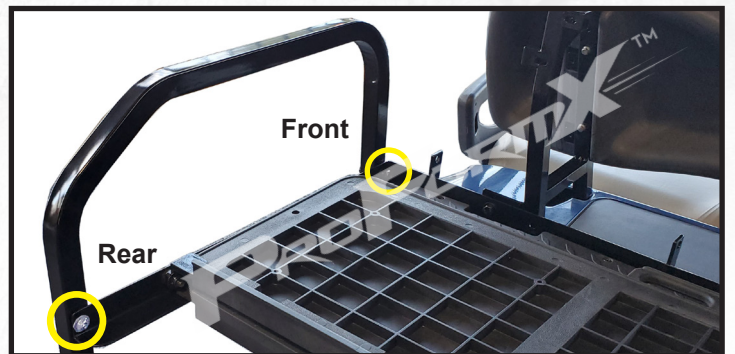

STEP 13

1) Using the 10mm x 25mm bolts and washers from Pack 3 secure the Footrest to the Bagwell Bracket as shown.

2) Attach the Footrest to each Armrest using the Footrest Brackets and 10mm x 85mm bolts and washers from Pack 3 as shown.

Note: Now tighten all hardware from previous steps using a 17mm wrench, 17 socket, 10mm socket, 5mm Allen wrench.

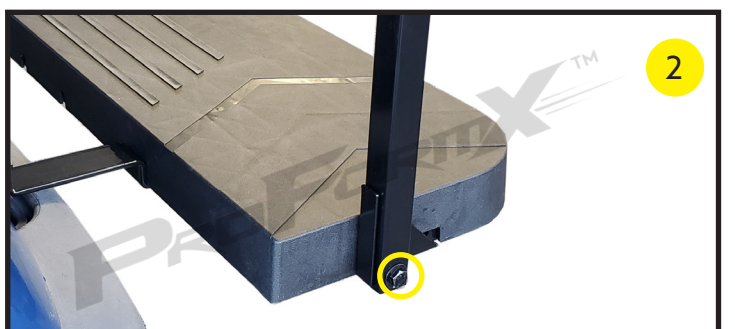

STEP 14

Attach the rear struts to the Seat Back Supports using the retained bolts from STEP 3.

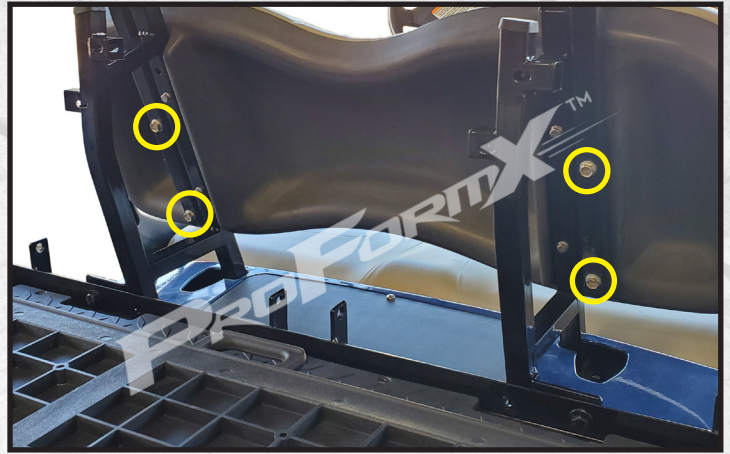

STEP 15

Reattach gutters to rear struts using bolts retained from STEP 2.



STEP 16

Using retained hardware from STEP 2, reattach canopy and rear gutter seals as shown.



STEP 17

Use a 10mm socket to attach the Lean Back Cushion to the Seat Back Support tabs with the 6mm x 50mm bolts and washers from Pack 4.

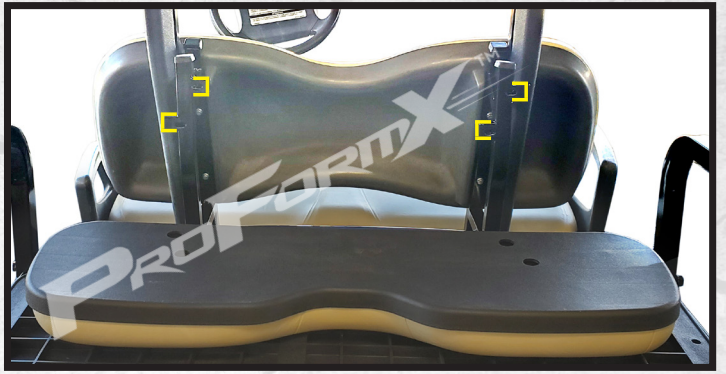

STEP 18

Using the 6mm x 40mm countersunk bolts from Pack 5 and a #2 Phillips tip screwdriver, attach the Seat Bottom to the flip frame as shown.

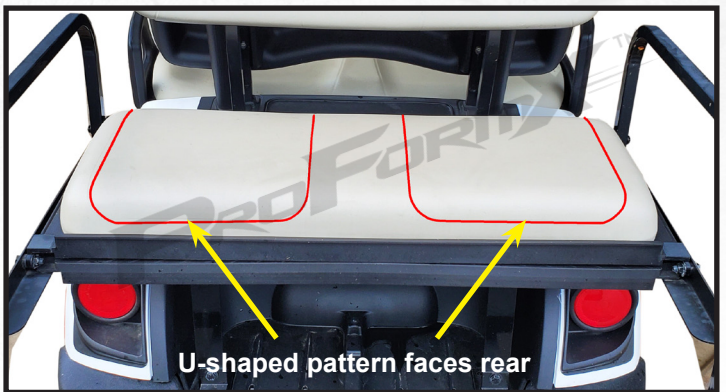

***Note:** Once ALL 8 bolts are started, then tighten.

PROFORMIX
TM

HARDWARE LIST

YAMAHA® DRIVE®

Pack 1: (Frame and Bagwell Bracket)

- 10mm x 25mm Shoulder Hex Bolts - 4
- 10mm x 25mm Flat Washers - 8
- 10mm Anti Slip Nuts - 4
- 6mm x 30mm Shoulder Hex Bolts - 2
- 6mm x 18mm Flat Washers - 2
- 6mm Lock Washers - 2

Pack 2: (Armrests)

- 10mm x 50mm Shoulder Hex Bolts - 2
- 10mm x 50mm Pan Head Bolts - 2 Challenger HD
- 10mm x 45mm Pan Head Bolts - 2 Challenger SE
- 10mm x 25mm Flat Washers - 8
- 10mm Anti Slip Nuts - 2
- 10mm Acorn Nuts - 2

Pack 3: (Footrest)

- 10mm x 85mm Shoulder Hex Bolts - 2
- 10mm x 25mm Shoulder Hex Bolts - 2
- 10mm x 25mm Flat Washers - 8
- 10mm Anti Slip Nuts - 4

Pack 4: (Lean Back Seat Brackets)

- 6mm x 50mm Shoulder Hex Bolts - 4
- 6mm x 18mm Flat Washers - 4
- 6mm Lock Washers - 4

Pack 5: (Seat Bottom)

- 6mm x 40mm Countersunk Bolts - 8



Club Car®, Precedent®, and DS® are registered trademarks of Ingersoll Rand, Inc. E-Z-GO®, TXT®, and RXV® are registered trademarks of Textron Innovations, Inc. ("Textron"). Yamaha®, G-14®, G-19®, G-22®, G-29®, and Drive2® are registered trademarks of Yamaha Golf-Car Company and Yamaha Motor Corporation ("Yamaha"). Reference to Club Car®, E-Z-GO®, or Yamaha® or their associated trademarks and products is only for purposes of identifying golf carts with which this ProFormX™ product is compatible. ProFormX™ products are aftermarket parts and are not original equipment parts. ProFormX™ is not connected or affiliated with or sponsored by Club Car®, E-Z-GO®, or Yamaha® or endorsed by Ingersoll Rand Inc®, Textron Innovation Inc®, or Yamaha Golf Cart Company®.

Bolt Length Gauge

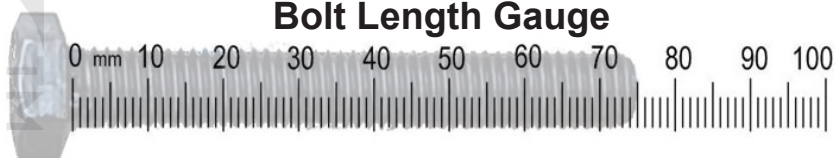

MYPROFORMX.COM