



# 6" SUPER HEAVY DUTY LIFT KIT

## INSTALLATION INSTRUCTIONS

Fits E-Z-GO® RXV® 2008-2015

PART# 60-202-KP



Front Suspension



Upper A-Arms



Rear Shock Plates



Warning Label



Front Spindles



Front Shocks



Rear Lift Blocks



Rear U-Bolts



Front U-Bolts

### TOOLS NEEDED

- 15/16" socket
- 19mm socket
- 17mm socket
- 15mm socket
- 13mm socket
- 17mm wrench
- 15mm wrench
- 13mm wrench
- 12mm wrench
- 3/4" wrench
- Cordless Drill (optional)

### PARTS LIST

- Front Suspension
- Front Spindles
- Upper A-Arms
- Rear Lift Blocks
- Rear Shock Plates
- Rear U-Bolts
- Hardware Pack
- Thread Locking Adhesive
- Front U-Bolts
- Front Shocks
- Warning Label

### Bolt Length Gauge

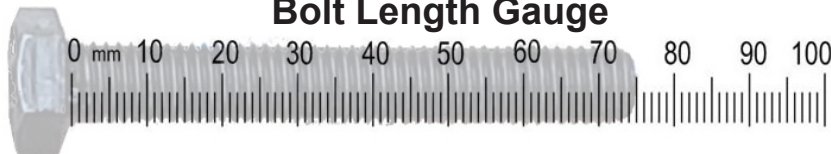



The Front Components of this Lift Kit will work on all RXV Models 2008-Current. The Rear Components of this Lift Kit will work on 2008-2015 electric models. For 2008-2015 Gas models use 60-204. For 2016 & Newer Gas Models use 60-205. For 2016-Newer electric models use 60-206.

## STEP 1

Switch key to the OFF position.

Place TOW/RUN switch to TOW.



## DEM PARTS REMOVAL

## STEP 2

Lift front of cart up with a floor jack and place jack stands under front frame.

Remove front wheels



## STEP 3

You will need to remove the front bumper to access the front suspension.

Using a 15mm socket and wrench remove and retain the front bumper nuts highlighted (1 on each side).





# STEP 4

Remove and retain front wheel hubs with a 15/16" socket and retain.

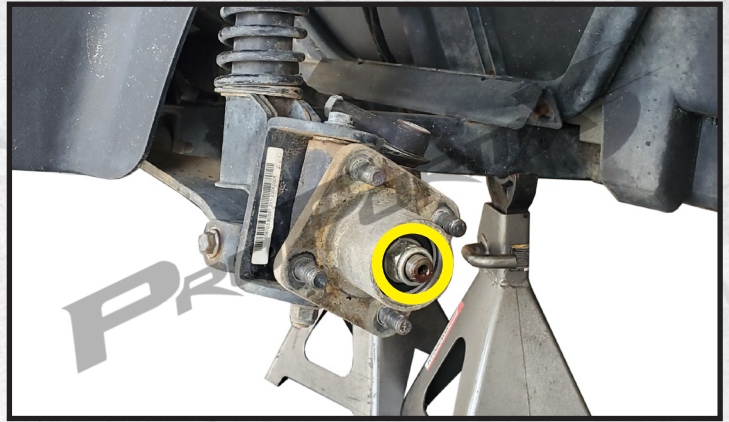

# STEP 5

Remove the cotter pin on the steering rack tie rod with needle nose pliers. Then remove the steering rack tie rod from the spindle with a 17mm socket.

Retain all hardware.



# STEP 6

*Note: If the tie rod will not easily release from the spindle flip the castle nut upside down and thread it on until it's flush with the bottom threads. This will help protect the threads.*

Tap the bottom of the tie rod with a hammer to release.





# STEP 7

Remove and Retain the upper shock nuts with a 15mm socket and wrench.

**Leave the shock bolts in place for now.**



# STEP 8

Using a 15mm socket and wrench remove and retain the lower control arm bolts from the frame at four locations.

*Note: At this point the only thing keeping the front suspension on is the upper bolts of the shocks.*

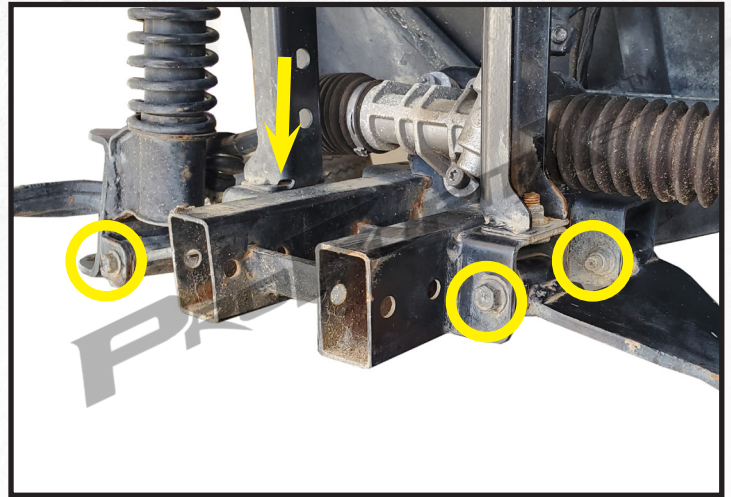

# STEP 9

Remove the upper shock bolts to release the front shocks, control arms, and spindles from each side.





# FRONT LIFT INSTALL

## STEP 10

Place the small U-bolts included with your kit over the frame behind the control arm mounts as shown.

Place the new Front Suspension under the frame and secure with the supplied nuts and washers.

Do **NOT** tighten hardware

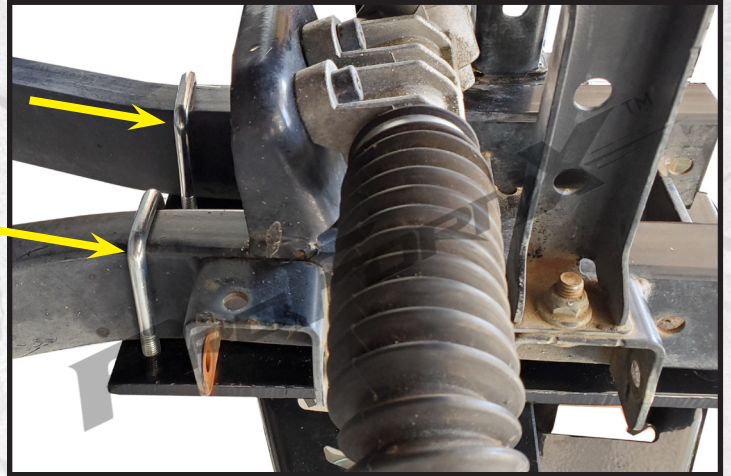

## STEP 11

Secure the front of the Front Suspension to the frame as shown with the supplied 16 x 50mm bolt using a 24mm or 15/16" socket.

Tighten all Front Suspension hardware.

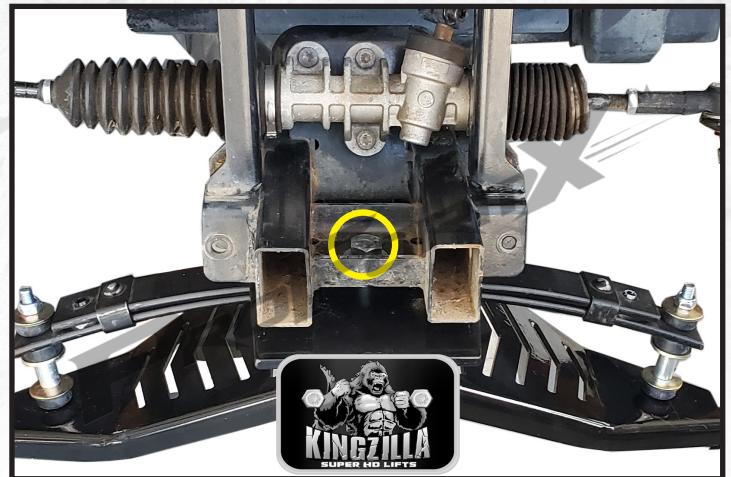

## STEP 12

**Before installing upper A-Arms grease zerk fittings.**

Install A-Arms using the bolts and nuts from **step 8**.

**Note:** Angled tube of A-Arm goes towards rear of cart as shown.

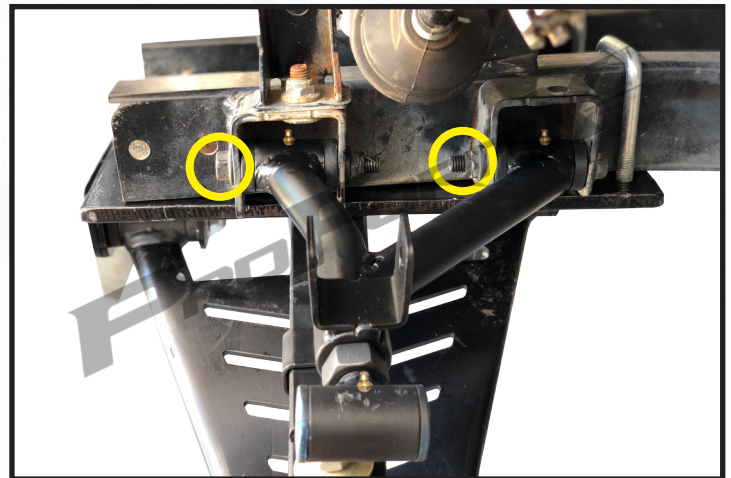

## STEP 13

Attach the new Shocks to the A-Arms with piston at top using 10x55mm bolts and hardware.

Do **NOT** tighten until after next step.

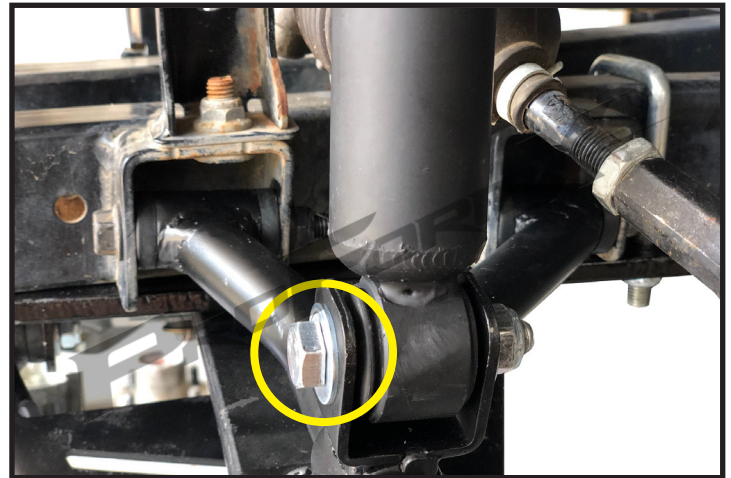



# STEP 14

Using the hardware from **step 7**, secure the top of the new Shocks.

**Note: Shock bolt inserts from rear and nut attaches on the front.**

You can now tighten all Shock hardware using a 16mm socket and 17mm wrench.



# STEP 15

**A)** Attach Spindle to the lower A-Arm using the supplied 10x100mm bolt using a 16mm socket and 17mm wrench.

**B)** Attach the Spindle to the upper A-Arm using the supplied 10mm x 75mm bolt and hardware. Tighten both bolts with a 16mm socket and 17mm wrench.

**C)** Attach steering rack tie rod using retained hardware and cotter pin from STEP 5.

Repeat on passenger side.

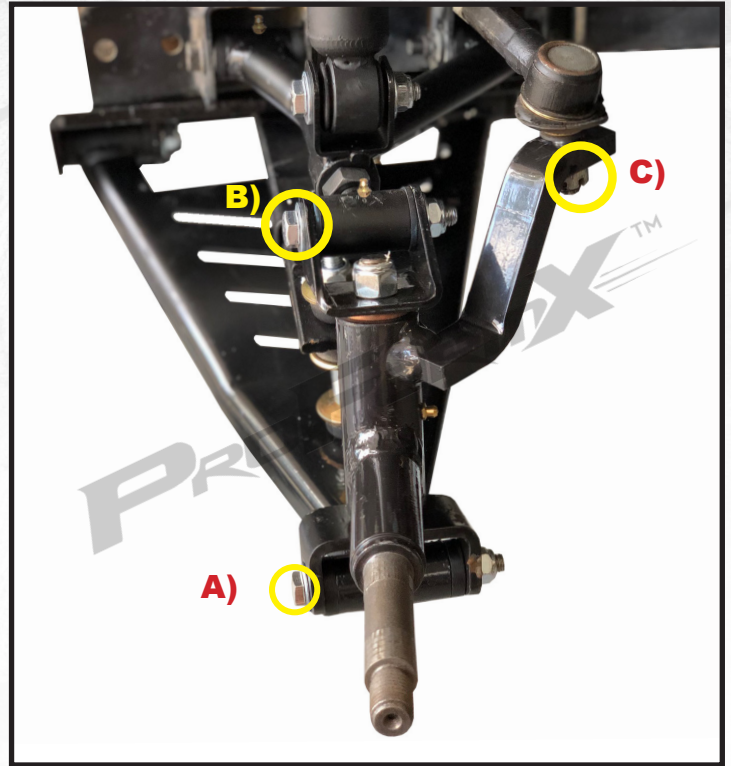

# STEP 16

Attach wheel hubs and dust caps from step 4 with a 15/16" socket. Tighten all the way, then back nut off quarter to half a turn so hub spins freely.





# STEP 17

Front lift kit is assembled, reattach the front bumper using nuts from step 3.

You can now install your new front tires/wheels using 1/2" Lug Nuts and remove jack stands.

**NOTE: We recommend 22-23" tires and 12" or 14" x 7" wheels for proper clearance.**



# REAR LIFT INSTALL

**The Following steps are for the 2008-2015 Electric Models. The Rear Components of this Lift Kit will work on 2008-2015 electric models. For 2008-2015 Gas models use 60-204. For 2016 & Newer Gas Models use 60-205. For 2016-Newer electric models us 60-206.**

# STEP 18

Disengage parking brake and chock front wheels. Use a floor jack under rear end to lift rear of cart up and place jack stands under frame.

Remove rear wheels.

**Note: Leave floor jack under rear end to support weight during install.**





# STEP 19

Loosen the Passenger side rear U-bolt from spring plate with a 15mm socket but **do NOT** fully remove nuts.

Remove the shock bolt from the shock mount.

*Important: This side needs to be loosened first before installing Driver's side lift blocks.*

*\*Now move to opposite side until after STEP 24.*

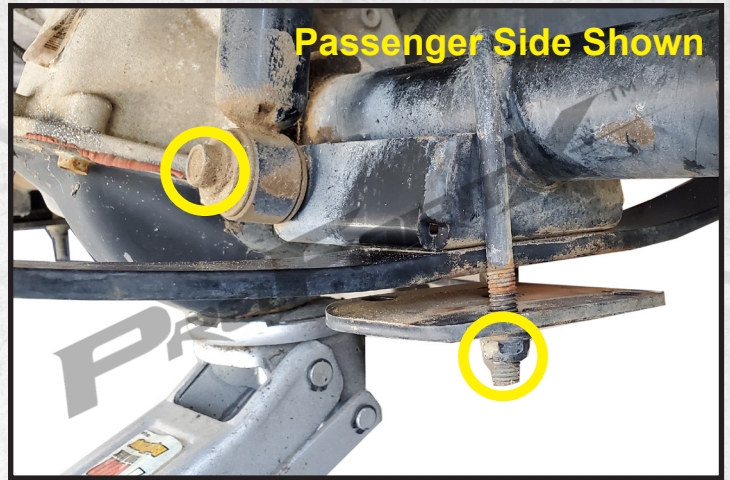

# STEP 20

1) Moving to the Driver's side, remove the factory U-bolt from the spring plate with a 15mm socket. Do NOT keep U-bolt or hardware.

2) Using a 15mm socket, remove and retain the shock nut and bushings from the rear axle.

3) Temporarily remove the front and rear leaf spring bolts highlighted with a 15mm socket.

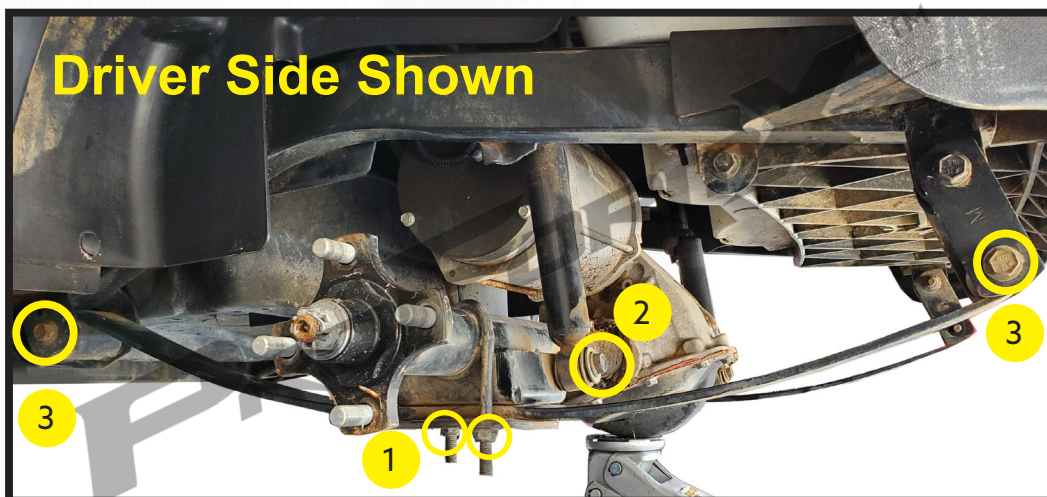

**Note: Leave floor jack under rear end to support weight during install.**



# STEP 21

The Driver's side axle is now free, make sure floor jack is still under motor/axle to support weight.

Carefully lower floor jack to allow enough room to install rear lift block. Reinstall leaf spring **ABOVE** axle using hardware from STEP 20.



Thin leg of lift block goes towards back of cart

# STEP 22

Place the new Rear Shock Plate on top of the leaf spring as shown.

Attach shock using the supplied 10mm x 55mm bolts and hardware. **Do NOT** tighten yet.

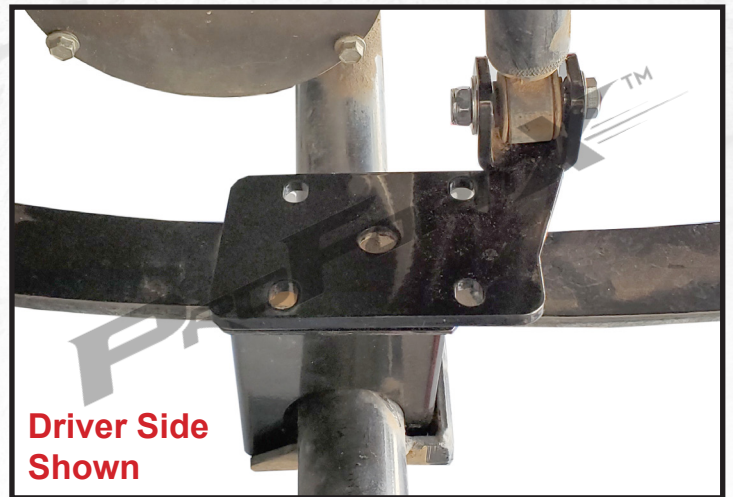

# STEP 23

Attach the supplied 8mm x 20mm hex head bolt, washer, and nut to the factory spring plate as shown using a 13mm socket and 13mm wrench.

Note: This bolts purpose is to keep the spring plate in line with the alignment hole located in the bottom of the axle.

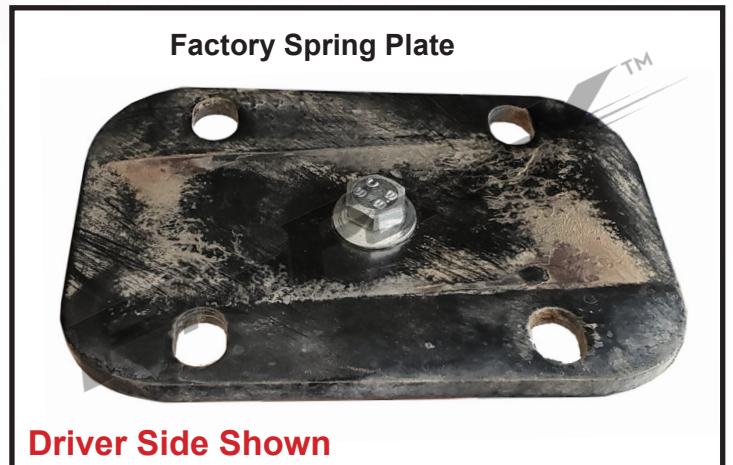



# STEP 24

Using the supplied U-Bolt and hardware, route the U-Bolt through the Shock Mount and down through the factory spring mount as shown. You may need to adjust the floor jack to make this step easier.

Once both ends of the U-bolt are in place, tighten hardware equally.

**Note:** Make sure the leaf spring nut is properly sitting inside the new Shock Plate hole and the Hex head bolt from STEP 23 is recessed in rear axle plate while tightening hardware. All components should be tight together with no gaps between. A rubber mallet can be used to help align components.



# STEP 25

Repeat STEPS 19-24 on Passenger's side.

Then install new wheels and tires using 1/2" x 20 Lug Nuts, lower cart, and proceed to alignment steps.





# STEP 26

## ALIGNMENT INSTRUCTIONS

### WARNING

After installing this lift, the front wheels must be properly aligned. Failure to properly align the front wheels may result in decreased ability to control the golf cart which may result in a rollover or crash.

**IMPORTANT:** Camber and toe must be adjusted for proper operation.

### CAMBER ADJUSTMENT

**IMPORTANT:** Both camber and toe must be adjusted on this model.

To adjust for proper camber, use a framing square, level, or some other means of verifying that the tire is at a 90 degree angle to the ground.

**A)** Using a 19mm socket, temporarily remove kingpin nut to adjust camber.

**B)** To achieve proper 90 degree camber, adjust upper A-Arm shackle in or out as needed.

**IMPORTANT:** Be sure to retighten the Kingpin Nut and Jam Nut on A-arm when finished.

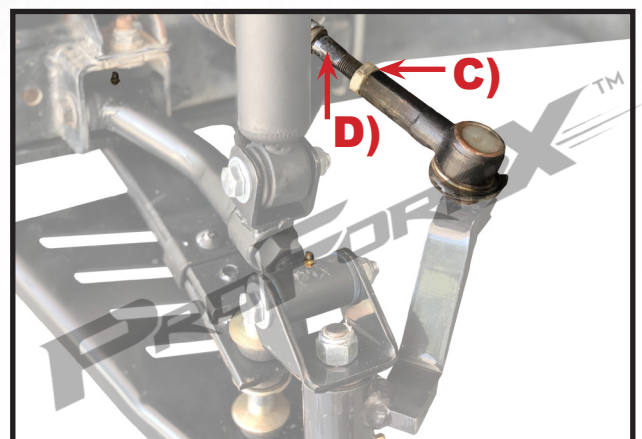
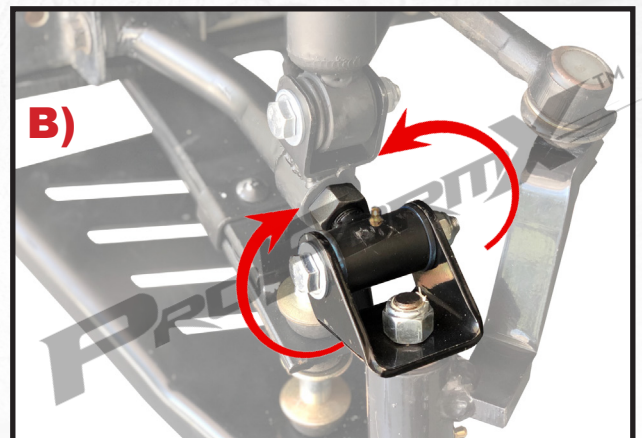

### TOE ADJUSTMENT

Ensure the wheels are pointing straight forward. To adjust toe, find a common point to measure from the inside front and inside rear of the front tires. Adjust until the front measurement is 1/4" greater than the rear measurement.

Loosen nut on tie rod end (**C**) and adjust steering rack (**D**) in or out as needed for proper alignment. Tighten nut on rod end when complete.

**IMPORTANT:** Ensure that after this adjustment, both wheels toe out from the cart's centerline equally.

Once tightened, test drive and re-check tow and camber measurements again.





# STEP 27



Warning label included with this kit must be installed and displayed in plain view of vehicle operator.

**WARNING**  
THIS VEHICLE CAN BE HAZARDOUS TO OPERATE

This vehicle has been modified for more ground clearance and has a higher center of gravity. If you fail to take proper precautions, a rollover or collision can occur quickly even during routine maneuvers such as turning, driving on hills, or over obstacles.

**SEVERE INJURY OR DEATH** can result if you do not follow these instructions.

This multipurpose vehicle has equipment features for off-road use. As a result, it handles differently than many other vehicles.

Sharp and abrupt maneuvers while turning along hillsides can cause loss of control possibly leading to rollover or accidents causing severe injury or death.

- **NEVER OPERATE THIS VEHICLE ON PUBLIC ROADS.** You can collide with another vehicle if you operate this vehicle on a public road.
- **ALWAYS WEAR AN APPROVED HELMET,** and protective clothing.
- **NEVER CONSUME ALCOHOL OR DRUGS** before or while operating this vehicle.
- **NEVER OPERATE THIS VEHICLE AT EXCESSIVE SPEEDS.** You increase your risk of losing control if you operate this vehicle at speeds too fast for the terrain, visibility conditions, or your experience.

**WARNING**

## HARDWARE LIST

## RXV®

### Hardware Pack

- 16mm x 50mm Hex Head Bolts - 1 (*Main Suspension*)
- 16mm Flat Washers - 2
- 16mm Nylock Nut - 1
- **10mm x 89mm x 120.5mm Square U-Bolts - 2 (Rear)**
- 10mm x 43mm x 105 Square U-Bolts - 2 (*Main Suspension*)
- 10mm x 100mm Hex Head Bolts - 2 (*Lower Spindle*)
- 10mm x 75mm Hex Head Bolts - 2 (*Upper Spindle*)
- 10mm x 55mm Hex Head Bolts - 2 (*Shocks*)
- 10mm x 55mm Hex Head Bolts - 2 (*Rear Shocks*)
- 10mm Flat Washers - 24
- 10mm Nylock Nuts - 16
- 8mm x 20mm Hex Head Bolts - 2 (*Spring Plate*)
- 8mm Flat Washers - 4
- 8mm Nylock Nuts - 2

Club Car®, Precedent®, and DS® are registered trademarks of Ingersoll Rand, Inc. E-Z-GO®, TXT®, and RXV® are registered trademarks of Textron Innovations, Inc. ("Textron"). Yamaha®, G-14®, G-19®, G-22®, G-29®, and Drive2® are registered trademarks of Yamaha Golf-Car Company and Yamaha Motor Corporation ("Yamaha"). Reference to Club Car®, E-Z-GO®, or Yamaha® or their associated trademarks and products is only for purposes of identifying golf carts with which this ProFormX™ product is compatible. ProFormX™ products are aftermarket parts and are not original equipment parts. ProFormX™ is not connected or affiliated with or sponsored by Club Car®, E-Z-GO®, or Yamaha® or endorsed by Ingersoll Rand Inc®, Textron Innovation Inc®, or Yamaha Golf Cart Company®.

### Bolt Length Gauge

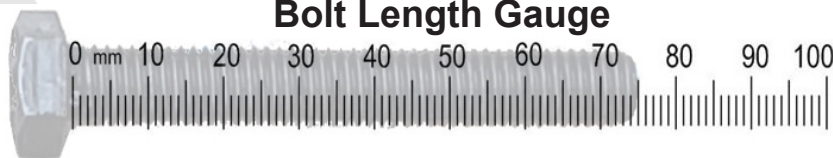

MYPROFORMX.COM