

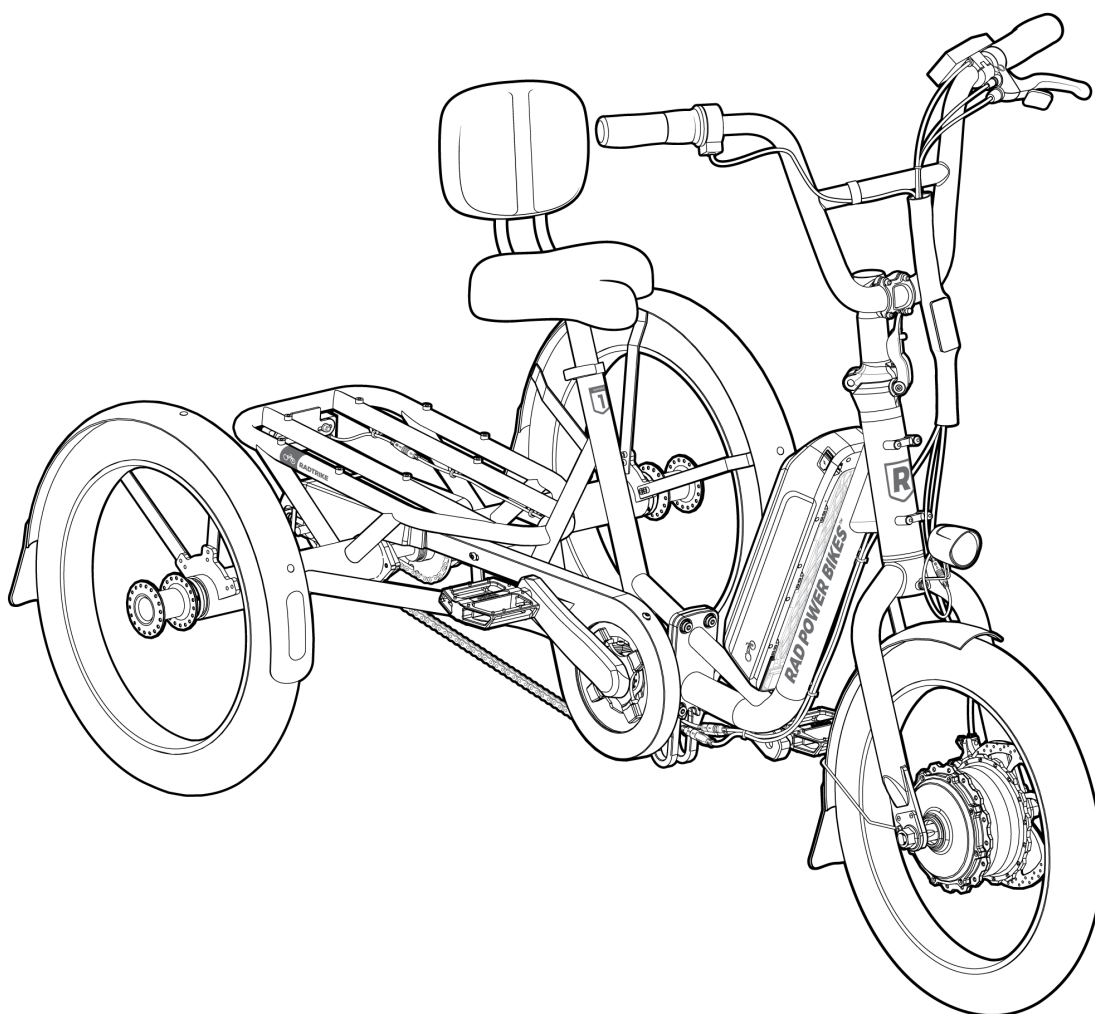



RadTrike™

OWNER'S MANUAL



Everyone at Rad Power Bikes cares about your safety and the safety of those around you. We want you to thoroughly enjoy your amazing trike safely and reliably for many years to come.

 **WARNING:** DO NOT alter or modify anything in your trike's electrical system, battery, digital controls, physical components, or drive train. Doing so may void your warranty. Any such modifications may result in damage to your trike, other property, or injury or death to you or others.

 **WARNING:** This trike is not to be operated by anyone under the age of 16. Children under the age of 16 may lack the necessary judgment and skill to safely operate the trike, potentially resulting in damage to the trike, damage to other property, serious injury, and/or death. Please also check your local laws, which may require a higher age. It is your responsibility to know and obey local regulations regarding rider age and other qualifications.



MINIMUM
OPERATOR AGE

 **DANGER:** Riding any bike, trike, or similar vehicle without a helmet puts you at **VERY HIGH RISK** of serious head injury or death. Always wear a properly fitted helmet that covers the forehead. Many locations require specific safety devices. It is your responsibility to familiarize yourself and comply with the laws, rules, and regulations where you ride.



WEAR A HELMET

 **WARNING:** Any bike, trike, or similar vehicle is subject to wear and tear, and certain components and fasteners can stretch or loosen with the vibrations and stress of normal operation. **You must check your trike before each ride** and according to the other checklists in this manual. Failure to do so could result in property damage, serious injury, or death.



PRE-RIDE CHECK
rad-go.com/safety

Please read, understand, and follow all safety notices, cautions, and warnings in this manual and for any accessories or attachments you add to make your trike perfect for you. **Stay safe! Ride Rad!**

Welcome to the Radventure!

Thank you for purchasing the RadTrike™ from Rad Power Bikes™!

We take pride in bringing you a quality product that will offer years of enjoyment. Please read and understand this manual fully before assembling and riding your trike. The latest version of your manual, your assembly video, and other helpful content is available at the QR code and URL at right.

Be sure to check all hardware for correct torque (see [“Tools and torque specifications” on page 11](#)) during assembly. Before each ride, follow the recommendations in the [“Safety checklists” on page 31](#). Finally, take care of your new RadTrike by following the guidelines in [“Recommended service intervals” on page 34](#). If you're not sure you have the skills, experience, and special tools required for assembly and maintenance, get help from a local, professional, and reputable bike mechanic.



rad-go.com/trike

WE ARE HERE TO HELP! If you have questions after reading this manual and watching the assembly video, please consult the Rad Power Bikes Help Center by using the QR code above or going to rad-go.com/trike.

Thanks for riding Rad!

Contents

Welcome to the Radventure!	1
Using this manual	3
Assembly instructions	4
Tools you need before you start	4
Assembly steps	4
Tools and torque specifications	11
Adjusting for comfort and safety	13
Adjusting the seat angle and back position	13
Adjusting the handlebar angle	13
Adjust the angle of the Rad UI Remote	13
Fine-tune the brake-lever positioning	14
Fine-tune brake lever feel	14
Ensure all hardware is tightened properly	14
Battery information	15
Battery features	15
Safe operating temperatures	15
Removing and installing the battery	16
Before you charge	16
Charging procedure	17
Estimated charging times	18
Estimated range per full charge	18
Best practices for extending range and battery life	19
Battery storage	19
Summary: Battery recommended temperatures	19
Additional critical battery safety information	20
Operation	21
How the electrical system works	21
Handlebar features	22
Rad UI functions and electrical controls	22
Brake features	23
Brake light	24
Start-up procedure	24
Turning and maneuvering	25
Riding on hills	25
Folding and unfolding your RadTrike's stem riser	26
Parking, storage, and transport	27
Carrying cargo	29

Weight limits	29
Carrying loads (cargo) safely	29
Carrying pets	30
Safety checklists	31
Maintenance	34
Check and service your trike regularly	34
Recommended service intervals	34
Checking brakes & motor cutoff switches	35
Tire and wheel care	36
Handlebar twist and push tests	37
Guard against rust, corrosion, and water damage	38
Troubleshooting	39
Error detection	40
Ride as safely as possible	41
Age and ability requirements	41
Know and obey all relevant local laws	41
Ride appropriately for conditions	41
Wear a helmet and appropriate safety gear	43
Limited warranty and other terms	44
Claims process	45

Using this manual

This manual contains critical details about how to safely operate and maintain your RadTrike. Read it carefully and familiarize yourself with your trike before riding it. Pay special attention to the safety messages shown here.

 **NOTICE:** A “notice” is important information that can help you avoid trike/property damage or extend the life of parts and the trike.



CAUTION: A “caution” statement indicates a hazardous situation that, if not avoided, could result in minor or moderate injury or property damage.



WARNING: A “warning” statement indicates a hazardous situation that, if not avoided, could result in death, serious injury, or property damage.



DANGER: A “danger” statement indicates a hazard that, if not avoided, has a very high risk of death, serious injury, or property damage.

Operating any bike, trike, or other vehicle always involves some risk of serious injury or death. Your safety depends on many factors including your skill, your trike’s maintenance, and riding conditions. There are also factors you cannot control or anticipate. This manual makes no representations about the safe use of this product under all possible conditions. If you have any questions you should contact Rad Power Bikes immediately.

Assembly and first adjustment of your trike from Rad Power Bikes requires special tools and skills. We recommend that you have this done by a professional, reputable bike mechanic. Keep this manual and any other documents that came with your RadTrike. All content in this manual is subject to change or withdrawal without notice. Visit radpowerbikes.com/manual to view and download the latest version. Rad Power Bikes makes every effort to ensure the accuracy of its documentation and assumes no responsibility or liability if any errors or inaccuracies appear within.

Assembly instructions

The following steps provide an overview of how to assemble your RadTrike from Rad Power Bikes. Please also see the assembly video available at rad-go.com/trike. Neither the assembly video, assembly steps, nor the rest of the manual cover all potential aspects of trike configuration, maintenance, and repair, which can require specialized tools and skills. We recommend you consult a professional, reputable bike mechanic to assist in the assembly, repair, and maintenance of your RadTrike.

Tools you need before you start

Your RadTrike comes with many but not all of the tools you will need for assembly. In addition to the provided tools, you will need the following:

- **Flat-side cutters.** These are useful for snipping zip ties and much safer than tools like box cutters.
- **Torque wrench or wrenches with Allen bits.** For assembly and maintenance, you will need to torque hardware across a range of torque values (0 Nm to 60 Nm) to ensure your trike is safe to ride.
- **15 mm pedal wrench or crowfoot bit.** Regular wrenches are too wide to fit between pedal and crank, and may make it impossible for you to properly secure your pedals without damaging them or your cranks. A 15 mm pedal wrench will fit properly, and an experienced mechanic can use such a tool to correctly tighten pedals to 35 Nm. If you do not have that skill level, you'll need a crowfoot bit (shaped like the end of a pedal wrench) to use with your torque wrench to secure your pedals to 35 Nm.
- **Bicycle grease.** Necessary to lubricate and/or prevent corrosion on certain parts.
- **Bike pump with Schrader valve and pressure gauge.** Properly inflated tires are a must for safety, comfort, and performance.
- **A strong friend.**

What is “torque”? Torque is rotational force. In the bike industry, torque is typically measured in units of Newton meters (Nm). Applying the right amount of torque to your fasteners (bolts, nuts, etc.) is critical for your safety. To “torque” accurately, use a high-quality torque wrench. Torque wrench accuracy depends on your technique (e.g., wrench angle and grip location), so be sure to read the instructions that came with your torque wrench.

If you plan to do your own tune-ups, repairs, and other maintenance, please refer to [“Tools and torque specifications” on page 11](#) for information on other tools needed for maintenance of certain components on your RadTrike. If you do not wish to acquire these tools for assembly and maintenance, we strongly recommend that you seek professional help to assemble and maintain your trike.

Assembly steps



WARNING: Incorrect assembly, maintenance, or use of your trike can cause component or performance failure, loss of control, serious injury, or death. Even if you're an experienced bike rider, **you must read and understand the entire manual and any documentation provided for subcomponents or accessories before riding.** If you are not sure you have the experience, skills, and/or tools to correctly perform all assembly steps in the manual and the assembly video at rad-go.com/trike, have a local, professional, reputable bike mechanic assemble your trike.

Please note that your trike may include components that look different from those in this manual's illustrations. Such changes help ensure uninterrupted production and shipping. Our engineers rigorously test each component to guarantee quality and compatibility.

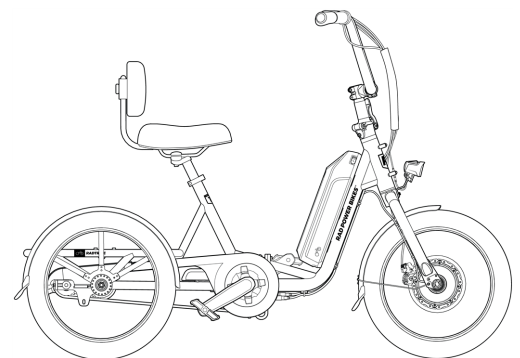

Fully assembled RadTrike

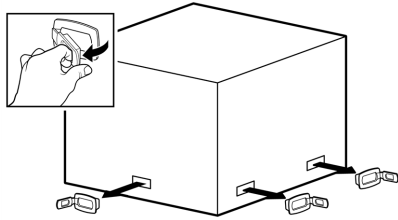

Remove the plastic handles.

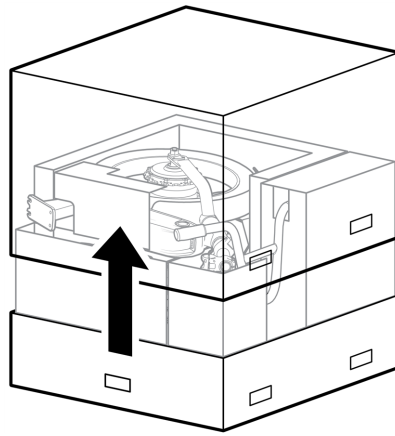

Lift the lid.

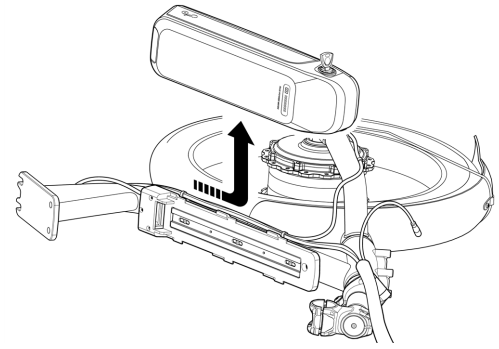

Before you remove the trike from the box, take the battery off to keep it safe.

1. **Unpack the trike.** The RadTrike is shipped in two large pieces (front and back). We recommend having a friend assist you with assembly.
 - a. **Remove the six (6) plastic handle tabs from the box,** and then lift off the top of the box.
 - b. **Remove the keys from the handlebar.** Use the key to unlock and remove the battery from the frame (see [“Start-up procedure” on page 24](#)). You will re-install the battery at the end of the assembly.
 - c. **Have a friend help you remove the front of the trike and the handlebar.** Carefully set them aside on a clean surface. Be careful not to twist the cables during removal. You will reorient the front wheel during assembly.
 - d. **Remove the seat and set aside.**
 - e. **Locate the accessory box and set aside.** This box contains various small parts and tools you will need for assembly.
 - f. **Remove all of the packaging except the lower cardboard tray.** Recycle all packaging as local rules allow.
 - g. **Flatten the sides of the lower tray.** Ensure the corrugated cardboard pieces securing the rear wheels and frame connection point were not dislodged during shipping. These help support and align the trike during assembly.
2. **Verify that all accessories are included.** Open the accessory box and verify all of the following items are included. If there are any missing parts, please contact Rad Power Bikes.

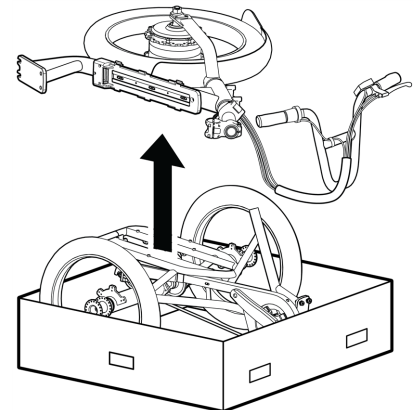

Have a friend help you remove the front wheel and handlebar.

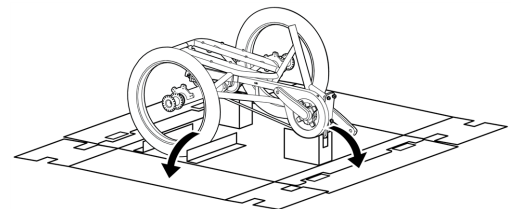

Lay the sides of the box flat.

- Handlebar stem faceplate and mounting bolts (4)
- Pedals
- Fenders (2) with attaching mounting arms
- Reflector kit
- Fender mounting hardware kit
- Assembly Toolkit
- Headlight
- Battery Charger

3. **Connect the front and rear of the trike.**

- a. **Use the 6 mm Allen wrench to unthread the four bolts on the frame connection point on the rear of the trike.** Remove the top two bolts and washers and set aside.

Unthread the longer bottom two bolts until the bolt end is flush with the back of the opening. Position the washers directly against the bolt heads.

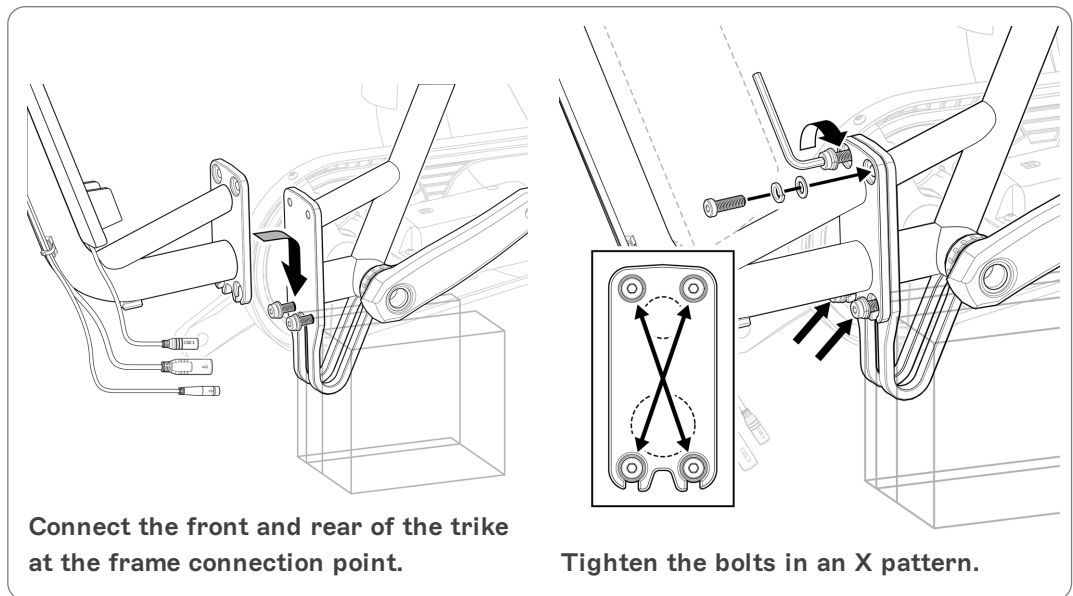

- b. **Carefully position the front of the trike over the bottom two bolts and washers on the frame connection point.**
- c. **Re-install the top two bolts and washers, and then partially tighten all four bolts in an X pattern.**
- d. **Use a torque wrench to evenly torque the four bolts** (see [“Tools and torque specifications” on page 11](#)).
- e. **Set aside the cardboard frame block.**

4. **Orient the front of the trike.** The front wheel was rotated for shipping and needs to be reoriented for assembly.

- a. **Ensure the wheel is in the correct position.** Set the bolts and faceplate aside near the handlebar.
- b. **Orient the handlebar.** Hold the handlebar up on the stem with the brake lever on the rider’s left side facing forward, and the throttle on the right.
- c. **Ensure the wiring harness is not twisted around the headset and the brake cable runs straight down to the front brake.**
- d. **Engage the parking brake to ensure the front wheel does not roll forward during the rest of the assembly.** See [“Brake features” on page 23](#) for more information about the parking brake.

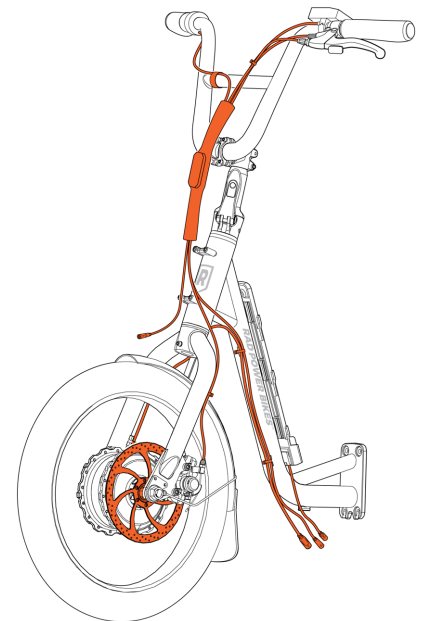

Front of trike with handlebar installed. Note the position of the brake rotor and the cables.

5. **Install the handlebar onto the stem.**

- a. **Verify that the lever on the stem riser’s locking mechanism is secured.** (The stem riser is the vertical part of the bike or trike that holds the stem and handlebar.) The stem riser is shipped in its locked position, but can be folded for storage when the lever is unlocked.
- b. **Locate the handlebar stem faceplate and mounting bolts** from the accessory box.
- c. **Center the handlebar on the stem.** Place the handlebar into position on the stem so it’s centered and the handlebar is approximately parallel with the front fork when viewed from the side.
- d. **Install the stem faceplate.** Place the stem faceplate over the handlebar and use a 5 mm Allen wrench to partially tighten the mounting bolts in an X pattern.
- e. **Use a torque wrench to evenly torque the four bolts** (see [“Tools and torque specifications” on](#)

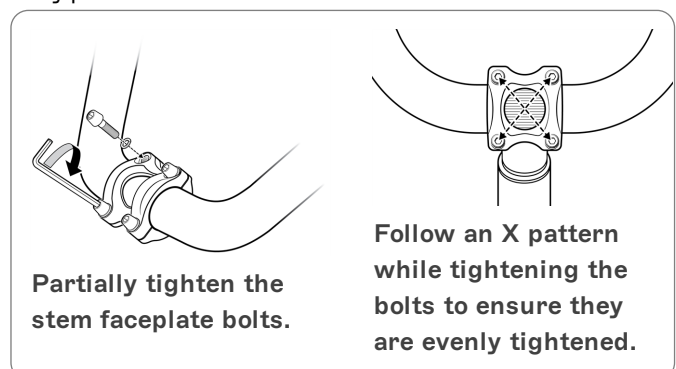

[page 11](#)). If you decide to adjust the angle of the handlebar later (e.g., to bring it slightly closer to the seat), be sure to follow the same procedures listed here to ensure the handlebar is properly secured.

6. **Connect the three cables at the center bottom of the frame.** These cables connect the motor and battery on the front of the trike to the controller on the rear of the trike.
 - a. **Route the rear halves of the three cables.** Push the rear cables up into the bracket opening beneath the frame connection point.
 - b. **Connect the three connector cables under the downtube.** The cables are color-coded to help you match them, but we recommend paying attention to the internal pin configuration to make sure your matches are correct.

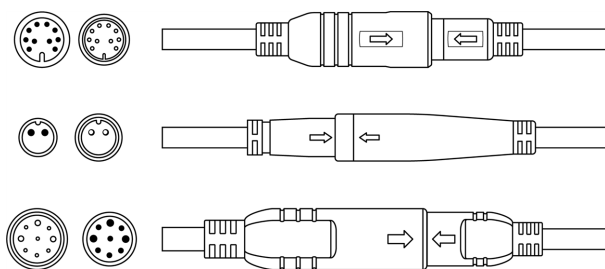

Top: The wiring harness connectors have a **gray stripe** on the cable. The connector interior has 10 small pins.

Middle: The battery connectors have **no color stripe** on the cable. The connector interior has 2 large pins.

Bottom: The motor connectors have a **white stripe** on the cable. The connector interior has 9 pins (3 large, 6 small).

- c. **Line up the internal notch and pins and the external arrows of the wiring harness cable, and press together without twisting.** Repeat the process for the battery and motor cables.
 - d. **Locate the zip tie in the accessory box.** Take up any slack from the cables, and then use the zip tie to secure the three cables to the mounting boss on the underside of the frame.
 - e. **Use flat-side cutters to snip off any excess from the zip tie.** Ensure the cut is flush and smooth with no sharp point.

7. **Install the headlight.**

- a. **Locate the headlight in the accessory box.** The headlight will be mounted to the front of the trike using the same bolt that connects the front fender to the fork.
- b. **Use a 4 mm Allen wrench to remove the bolt on the front fork and fender.**
- c. **Feed the bolt through the washer, headlight bracket, and fork mounting point.** Mount the fender on the rear with the washer and lock nut. Use the 4 mm wrench to tighten the bolt.
- d. **Plug in the headlight connector.** Unzip the wiring harness cover and locate the headlight cable end (red interior). Line up the internal notch and pins and the external arrows on the headlight connectors, and press together without twisting.
- e. **Adjust the headlight angle slightly downward** so that it will illuminate the road ahead without blinding oncoming traffic.
- f. **Use a torque wrench to torque the mounting bolt.** See [“Tools and torque specifications” on page 11](#).

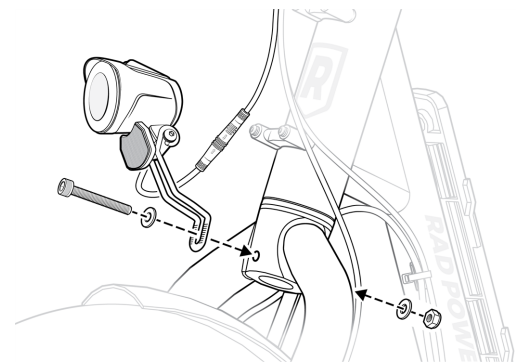

Headlight installation.

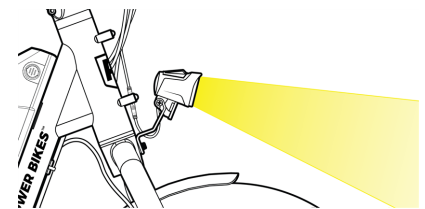

Angle the headlight slightly downward.

8. Install the pedals.

- a. **Locate the right-side pedal**, which is marked “R,” should have an “R” sticker attached, and has a smooth pedal axle. The right pedal goes on the crank on the drivetrain side of the trike, which has the chain and is the same as a rider’s right side when seated on the trike.
- b. **Place a pea-size or slightly smaller amount of bicycle grease onto the threads of the right pedal.**
- c. **Carefully thread the right pedal onto the right crank by turning clockwise.** Do so *slowly and gently* by hand. Do not cross thread or damage the threads. See the [“Right pedal installation”](#) illustrations.
- d. **Place a pea-size or slightly smaller amount of bicycle grease onto the threads of the left pedal.**
- e. **Carefully thread the left pedal onto the left crank by turning counterclockwise.** The reverse-threaded left pedal is marked with an “L,” should have an “L” sticker attached, and has notches on the pedal axle. Thread *slowly and gently* by hand without cross-threading or damaging the threads. See the [“Left pedal installation”](#) illustrations.
- f. **Tighten each pedal using a pedal wrench** to avoid damage caused by wider wrenches, as shown in the assembly video at radpowerbikes.com/assemble.
- g. **Torque each pedal to 35 Nm.** If you are not an experienced bike mechanic, you’ll need to use a crowfoot bit on a torque wrench to accurately torque the pedals. Be sure to install the crowfoot bit at a right angle to the torque wrench.
- h. **Wipe off any excess bicycle grease.**

RIGHT PEDAL INSTALLATION

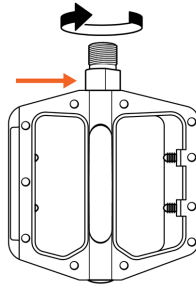

Right pedal with smooth pedal axle.

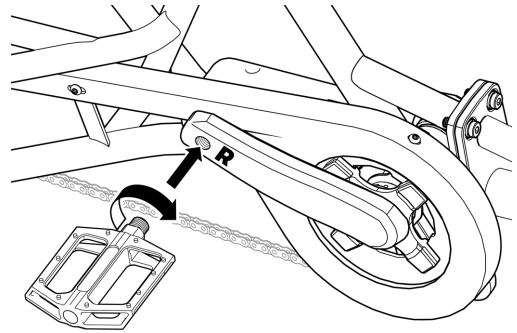

Thread the right pedal onto the right crank *slowly and gently* by hand, turning clockwise.

LEFT PEDAL INSTALLATION

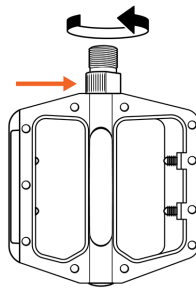

Left pedal with notches on the pedal axle.

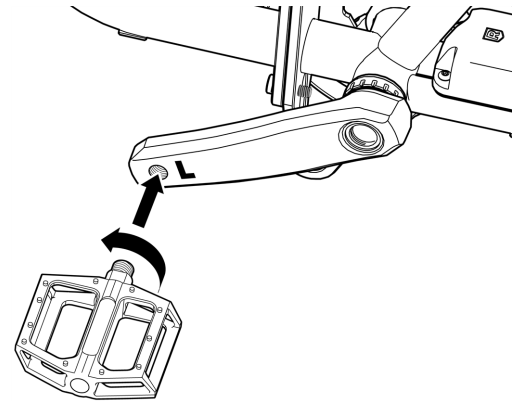

Thread the left pedal onto the left crank *slowly and gently* by hand, turning counterclockwise.

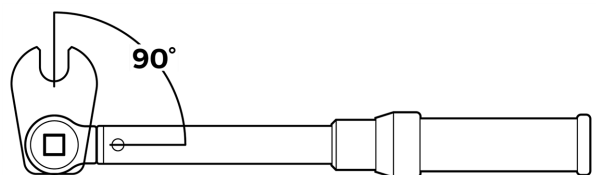

Torque wrench with crowfoot bit for accurately securing the pedals

9. Install the seat.

- a. **Open the seatpost quick-release lever.**
- b. **Place a pea-size amount of bicycle grease on the seatpost.** Evenly coat below the minimum insertion line.

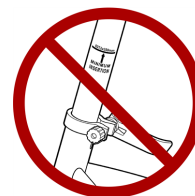
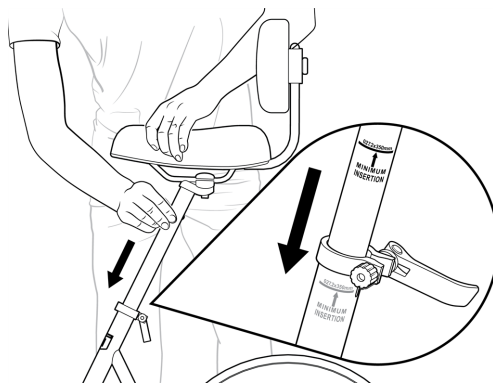

Seatpost out TOO FAR

The minimum insertion point on the seatpost must be inserted into the seat tube.

- c. **Insert the seatpost into the seat tube.** Adjust the seatpost to a height appropriate for your leg length and preference. You'll get the most efficient pedaling if your seat height allows you almost full leg extension when you are seated and your feet are at the bottom of a pedal stroke.



DANGER: Overextending the seatpost can cause it to break or fall off your trike, which will put you at very high risk of serious injury or death. Avoid this danger by inserting your seatpost into the seat tube far enough that the minimum insertion point is no longer visible.

- d. **Align the quick release opening with the notch in the seat tube,** and close the quick-release lever fully. When closed, the seat should not move up, down, left, or right. If needed, adjust the lever tension by turning the adjustment nut opposite the quick-release lever.
- e. **Try out your seat fit.** If your seat height needs more fine-tuning, repeat the steps above. Information on adjusting your seat angle back position is in [“Adjusting for comfort and safety” on page 13.](#)

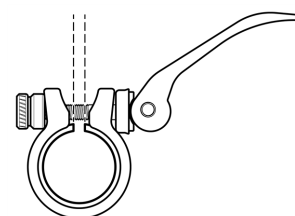

Align the quick release opening with the notch in the seat tube.

- 10. **Perform a handlebar twist and push test** to ensure the handlebar and stem are secure (see [“Handlebar twist and push tests” on page 37.](#))

- 11. **Inflate the tires.** Check that the tire beads and tires are evenly seated (fully inserted into the rims). Use a pump with a Schrader valve and pressure gauge to inflate each tire to the recommended PSI (pounds per square inch) indicated on the tire sidewall. Do not overinflate or underinflate tires. For more information, see [“Tire and wheel care” on page 36.](#)

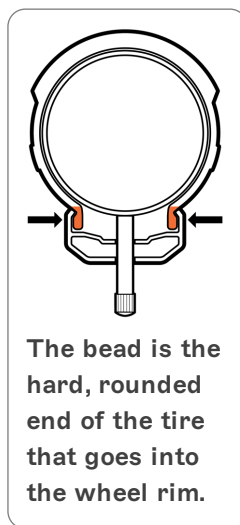

The bead is the hard, rounded end of the tire that goes into the wheel rim.

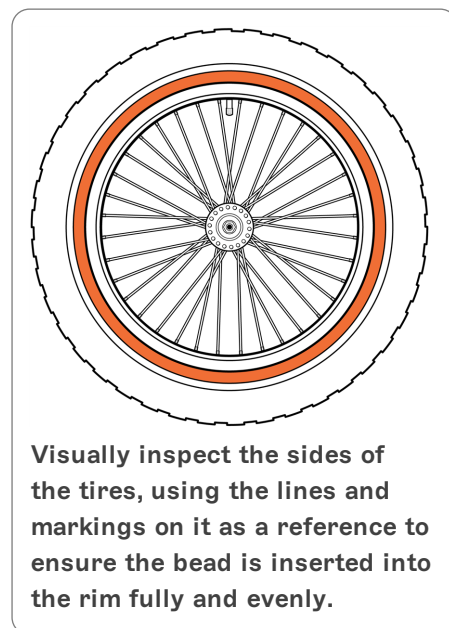

Visually inspect the sides of the tires, using the lines and markings on it as a reference to ensure the bead is inserted into the rim fully and evenly.

12. **Install the reflectors.** The reflector kit will include a headlight reflector (white) and a rear reflector (red). Spoke reflectors come pre-installed. Reflectors increase your safety by making you more visible to other vehicles, and they are required in some areas. It is your responsibility to know what your local laws require.

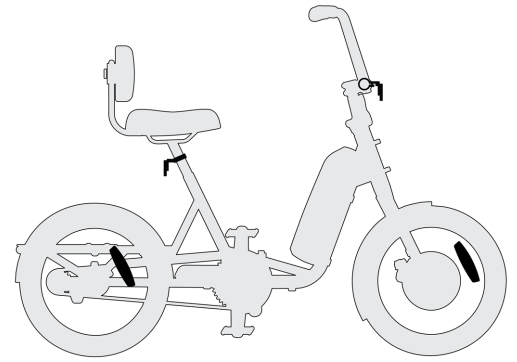

Reflector locations.

- a. **Mount the headlight reflector.** Use a Phillips head screwdriver to remove the mounting bolt from the white headlight reflector. Mount the reflector and shim (if necessary) on the handlebar, where it will be visible to oncoming traffic. Secure the mounting bolt. See [“Tools and torque specifications” on the next page.](#)
- b. **Mount the rear reflector.** Remove the mounting bolt from the red rear reflector. Mount the red reflector and shim (if necessary) on the seatpost where it will be visible to traffic behind you. Secure the mounting bolt. See [“Tools and torque specifications” on the next page.](#)

13. **Install the fenders.**

- a. **Identify which fender goes on which side of the trike.** Hold the two fenders with the mudflaps and reflective strips facing you. The mounting arms should be on the inside, facing each other.
- b. **Place the right fender over the drive side rear wheel.** The three mounting arms need to be on the inside (inboard) side of the rear axle mounting flange. The mudflap and reflective strip should be at the rear of the trike. See the illustration.
- c. **Secure the fender mounting arms to the flange.** Use the four mounting bolts from the fender mounting hardware kit. Tighten first by hand, and then using a 4 mm Allen wrench.
- d. **Place the left fender over the other rear wheel.** Secure it to the flange with four bolts as in the previous step.
- e. **Use a torque wrench to evenly torque all eight fender mounting bolts** according to the specifications in [“Tools and torque specifications” on the next page.](#)

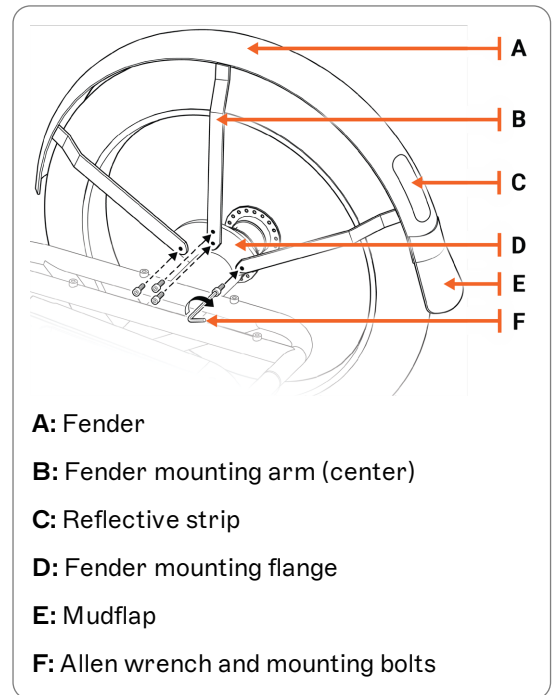

14. **Reinstall the battery.** Lock it into place (see [“Removing and installing the battery” on page 16](#)) and ensure it is securely mounted.

15. **Prepare the trike for use.**

- a. **Complete all steps** in [“Adjusting for comfort and safety” on page 13](#), including checking that all hardware has been tightened according to the values in [“Tools and torque specifications” on the next page.](#)
- b. **Perform the safety checks** in [“Maintenance” on page 34](#) including the handlebar twist and push test in [“Handlebar twist and push tests” on page 37.](#)
- c. **Place the Rider Quick Reference card.** If you’re assembling the trike on behalf of the operator, be sure to use the supplied zip ties to attach the Rider Quick Reference card to the handlebars as shown in the illustration. If you are the operator, be sure to read the card and post it someplace for easy reference. We recommend hanging it with the Safety Check side facing out near wherever you prep your trike before each ride.
- d. **Power on the trike** as described in [“Start-up procedure” on page 24.](#)
- e. **Release the parking brake and Ride Rad!**

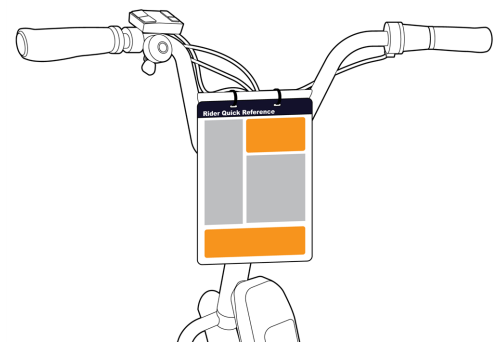

Attach the Rider Quick Reference card to the handlebar if you're assembling the trike for someone else.

Tools and torque specifications

The tool sizing listed below is a general guide, but it is possible that the head of a particular bolt on your trike may vary, requiring a different tool (e.g., a 4 mm Allen wrench instead of a 5 mm Allen wrench). If so, use whatever tool fits the bolt head. Such differences will not affect the recommended torque for that piece of hardware.

If you are installing accessories from Rad Power Bikes, any necessary instructions, important safety information, and torque specifications will come with your accessory and/or be available online at radpowerbikes.com/help.

	Tool	Torque
HANDLEBAR AREA		
Stem faceplate bolts (four bolts)	5 mm Allen	8-10 Nm
Stem clamp bolts	5 mm Allen	13-15 Nm
Stem riser clamp bolt(s) (below the folding mechanism)*	see "STEM RISER A" and "STEM RISER B" illustrations below*	
Folding mechanism gap bolt (bolt in the center bottom of the locking mechanism's interior)	5 mm Allen	5-7 Nm
Rad UI Remote clamp bolt	3 mm Allen	Tighten securely; do not over-tighten
Bell clamp bolt	Phillips head.	Tighten securely; do not overtighten
Brake lever clamp bolt	5 mm Allen	6-9 Nm
Handlebar grip bolts	2 mm Allen	3-4 Nm
Throttle clamp bolt	3 mm Allen	2-3 Nm

FORK AND FRONT WHEEL AREA

Headlight/front fender mounting bolt	4 mm Allen	6-8 Nm
Front axle nut	21 mm wrench	45-50 Nm
Caliper adapter to frame	5 mm Allen	6-8 Nm
Caliper to adapter	5 mm Allen	6-8 Nm
Cable pinch bolt on caliper arm	5 mm Allen	6-8 Nm
Brake rotor to hub bolt	T-25 Torx bit	6-8 Nm
Front wheel torque arm bolts	5 mm Allen	4 Nm
Brake pads to caliper	Needle-nose pliers	90° bend at tip of cotter pin

CENTER OF TRIKE (SEAT AND BOTTOM BRACKET/CRANK AREA)

Seat adjustment bolt	6 mm Allen	18-20 Nm
Frame connection point (4 bolts)	6 mm Allen	19-22 Nm
Pedal into crank arm	15 mm pedal wrench	35 Nm
Crank arm bolt into bottom bracket spindle	8 mm Allen	33-35 Nm
Crank arm removal info	Crank puller for square tapered bottom bracket spindle	

Chainring bolts	6 mm Allen	8-10 Nm
Controller mounting bolts	5 mm Allen	2-3 Nm
Chainguard mounting bolts	5 mm Allen	2-3 Nm
Bottom bracket and cups	BBT-22 Park Tool	50-55 Nm

REAR WHEEL AREA

Rear wheel hub (non-drive side)	14 mm socket head (M8 - 1.75)	30-35 Nm
Rear wheel hub (drive side)	19 mm socket head (M12 - 1.75 locknut)	30-35 Nm
Coaster brake hub	15 mm wrench	30-35 Nm
Rear fender bolts	5 mm Allen	2-3 Nm
Rear fender arm bolts	5 mm Allen	4-5 Nm
Taillight mounting bolt	4 mm Allen	3-4 Nm

* Your RadTrike will come with one of the following folding stem risers. Please use the tool and the torque values appropriate for the component on your trike.

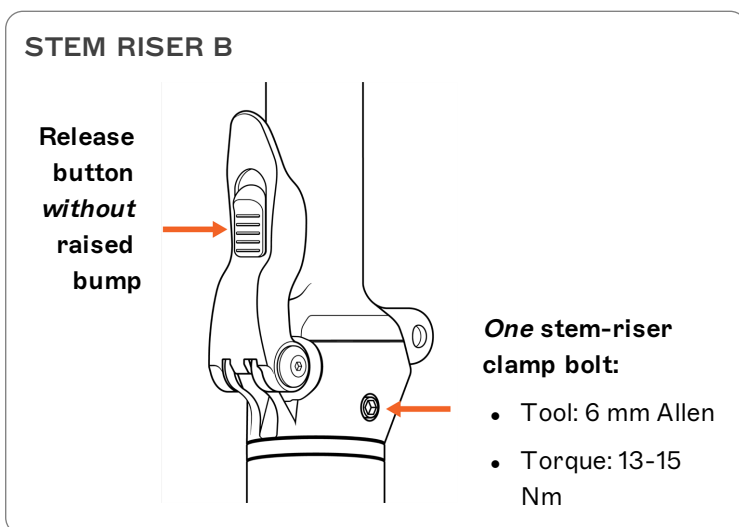
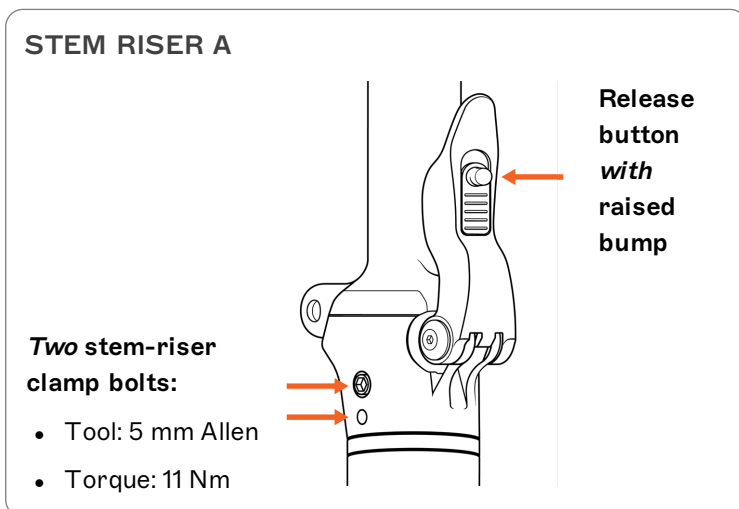

Adjusting for comfort and safety

The following steps are critical for your comfort and safety, and **must** be performed before your first ride. We recommend that you consult a professional, reputable bike mechanic who specializes in bike fit.

Adjusting the seat angle and back position

Many riders will prefer the seat to be roughly parallel to the ground, with its horizontal position in the middle of the range marked on the seat rails. To change the angle and horizontal position of the seat:

1. Use an Allen wrench to loosen (but do not remove) the seat adjustment bolt on the clamp located underneath the seat.
2. Move the seat backward or forward and tilt to adjust the angle. Do not exceed the limit markings etched into one of the seat rails, which show how far you can safely move the seat forward and backward.
3. Ensure the top of the seat rail clamp is aligned directly over the bottom of the clamp so that the seat adjustment bolt will clamp the seat rails properly. While holding the seat in the desired position, use an Allen wrench to tighten the seat adjustment bolt securely to the torque value listed in [“Tools and torque specifications” on page 11](#).

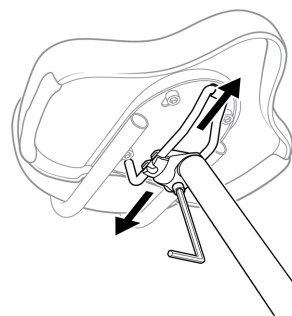

Seat adjustment bolt with Allen wrench

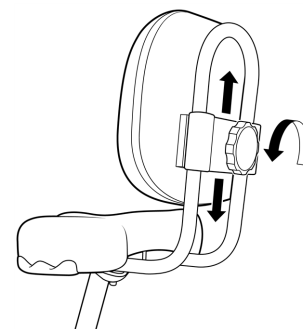

Adjusting the back height



WARNING: A loose seat clamp or seat adjustment bolt can cause loss of control, trike/property damage, serious injury, or death. Prior to first use, be sure to torque the seat adjustment bolt according to the specification in [“Tools and torque specifications” on page 11](#). Regularly check that bolt and make sure that the clamp on the underside of your seat is secure on the seat rails.

4. To adjust the seat back, loosen the hand knob on its back and adjust the height as you prefer. Tighten the hand knob and pull on the seat back to check that it's secure.

Adjusting the handlebar angle

Most riders will feel comfortable with the handlebar angled so that it is roughly parallel with the front fork, as shown in the center position in the illustration. Once you have adjusted the seat to your leg length and preference, you may decide that you would like the handlebar to be angled slightly closer to the seat. If so, follow these steps.

1. **Loosen the stem faceplate bolts** just enough to allow the handlebar to pivot, and position it as you prefer.
2. **Re-tighten the stem faceplate bolts** using the method described in the assembly instructions.
3. **Test the positioning by sitting on the trike**, making sure it's comfortable and that the handlebar can turn freely without touching your body.
4. **Inspect the stem faceplate bolts.** Be sure the gap between the faceplate and stem are even and torque all faceplate bolts according to the value listed in [“Tools and torque specifications” on page 11](#).
5. **Test the security of your handlebar by performing a handlebar push test.** See [“Handlebar twist and push tests” on page 37](#).

Adjust the angle of the Rad UI Remote

For best screen visibility and to prevent glare, angle the Rad UI Remote so that it is not facing directly at the rider, but is tilted slightly away.

1. **Loosen the Rad UI Remote clamp bolts.** Loosen just until the UI Remote can rotate on the handlebar. Do not remove the bolts.
2. **Rotate the Rad UI Remote and test the positioning.** The angle that will minimize glare and optimize visibility of the screen will depend on the rider's height and biking position. The screen should be tilted away from the rider but not

tilted so far that it's horizontal. Test the position while seated on your trike outdoors, in sunlight. Adjust as desired.

3. **Tighten the Rad UI Remote clamp bolts.** Tighten to the torque value listed in "[Tools and torque specifications](#)" on [page 11](#).

Fine-tune the brake-lever positioning

The angle of the brake lever can be adjusted for the most comfortable hand position possible. For most riders, this will allow them to rest two or three fingers comfortably on the brake lever while keeping their wrist in a neutral position. To adjust the angle, follow these steps:

1. **Loosen the brake lever clamp bolt** using the appropriate Allen wrench.
2. **Adjust the angle of the brake lever** so it's comfortable for the rider.
3. **Retighten the brake lever clamp bolt** according to the value listed in "[Tools and torque specifications](#)" on [page 11](#).

TIP! Another way to maximize hand comfort is to angle your handlebar grips so that the wide section of the grip supports the outside part of your palm and keeps your wrists are in a neutral position while you have two or three fingers resting on each brake lever. You should be able to reposition the handlebar grips by applying firm pressure and twisting. If they don't move, you can apply a small amount of rubbing alcohol between the grip and the handlebar as temporary lubrication:

1. **Carefully insert a screwdriver between the handlebar tubing and the grip.**
2. **Pry the grip away from the handlebar slightly.**
3. **Use a paper towel or squeeze bottle to apply alcohol into the gap.** This should help loosen the grip.
4. **Twist your grip into the best position for your comfort,** testing by trying the brake levers while seated.
5. **Give the alcohol an hour to evaporate,** and then test that your grips are secure before riding your trike.

Fine-tune brake lever feel

The "feel" of the brake lever is controlled by the brake cable tension, which determines how far the brake lever needs to be squeezed for the brake pads to press against the brake rotor. We recommend that the brake cable tension be such that squeezing the lever halfway between the starting position and the handlebar grip results in a firm lever feel, indicating that the brake pads are pressing against the brake rotor.

If needed, you can make fine adjustments to the brake cable tension by rotating the barrel adjusters at the brake lever housing and/or at the brake caliper on the front wheel.

For more information on brake lever feel and brake cable tension, please see the resources in our Help Center at radpowerbikes.com/help.



DANGER: Always make your brake levers can't touch the handlebar grip when you squeeze firmly. A brake lever that can touch the grips may not engage the brakes fully, causing you to have difficulty slowing or stopping and putting you at very high risk of serious injury or death. Squeezing the brake lever halfway toward the handlebar grip should cause the brake pads to press firmly against the brake rotor. If you think your brakes may not be functioning properly, do not ride your trike. Check our online Help Center for more information (radpowerbikes.com/help).

Ensure all hardware is tightened properly

Ensure all hardware is tightened properly according to the values in "[Tools and torque specifications](#)" on [page 11](#). **This is a critical safety step that you must not skip.** If you do not own a torque wrench or you do not have the skills to check the tightness of your hardware, consult a local, professional, reputable bike mechanic for help. You can find more information about bike fit and making adjustments to your trike in our Help Center at radpowerbikes.com/help.

Battery information

The battery that comes with your RadTrike is a state-of-the-art, lithium-ion battery that's designed to give you years of power with proper care and use. Follow the recommendations here for the best possible performance.

Battery features

Please familiarize yourself with all of the components of your battery. When you are seated on your trike, the charging port of your battery will be on the right side of the battery.



CAUTION: Do not put any object into your battery's charging port other than the Rad Power Bikes charging plug designed for this purpose (and pictured in the illustration). Inserting other objects into the charging port could damage your battery.

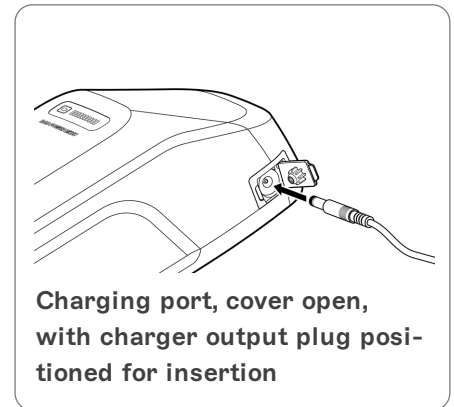
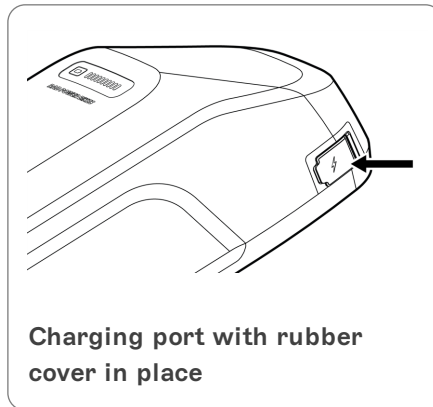

The other side of your battery includes the keyport. Use your key to lock or unlock your battery from the frame and to turn the battery on (make its power available to your trike's electrical system). **Always remove your key from the battery before riding.**

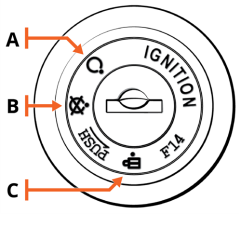

KEYPORT AND KEY POSITIONS

	Description
A	Power on, battery locked to frame
B	Power off, battery locked to frame
C	Power off, battery unlocked from frame (for battery installation and removal)

CHARGE LEVEL

On the top of your battery there is a button and 10 charge indicator LED lights. When you press the button, the LEDs will give you an approximation of your charge level: zero lights indicate zero or nearly zero charge, one light indicates about a 10% charge, two lights indicate about a 20% charge, and so on. When the battery is nearly empty, the first LED will blink.

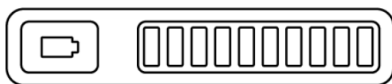

Button and charge indicator lights on the battery top.

You can also assess your battery's charge level via the Rad UI Remote on your handlebar (see "[Rad UI functions and electrical controls](#)" on page 22 for more information). It's possible for your battery's indicator lights and your Rad UI Remote to report slightly different charge levels. That's okay. If you notice a significant difference, this may indicate a problem in the electrical system. Please see "[Troubleshooting](#)" on page 39 for more information.

Safe operating temperatures

We recommend riding in temperatures between 5°F to 105°F (-15°C to 40°C). Colder or hotter temperatures increase risks to your health and can also cause harmful internal battery temperatures.

Riding in very hot temperatures: Know and respect your physical limits around exercising in hot

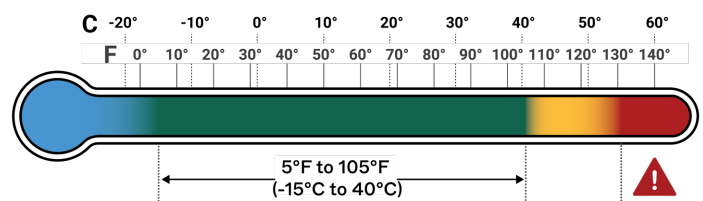

temperatures, and consult your doctor if you have any concerns. To prevent damage to your battery, do not ride in temperatures above 105°F (40°C). If you choose to ride in extremely hot temperatures, use low levels of power assistance (low pedal assist levels, low use of throttle) to keep the battery as cool as possible. This may lower the risk of the battery automatically turning off to prevent use-caused heat damage.



DANGER: Do not ride in extremely hot temperatures. The more the ambient temperature exceeds 105°F (40°C), the greater your risk of exceeding a maximum internal battery temperature of 131°F (55°C). This can cause the battery to turn off as a safety precaution. Extreme heat may also cause critical failure of the battery up to or including an electrical fire. Factors that increase your risk for battery overheating include, but are not limited to, ambient temperatures above 105°F (40°C), direct sunlight for extended periods, high throttle usage, high PAS level, high payload, steeper inclines, and other environmental factors.



WARNING: Extreme cold of 5°F (-15°C) or below can cause the battery to shut off automatically to prevent damage. Do not depend on battery power to return you back to safety if riding near those extreme temperatures. Riding in freezing temperatures can also expose your trike to de-icing salt, which can harm your trike and electrical components or cause an electrical fire. See [“Guard against rust, corrosion, and water damage” on page 38](#) for more information.

Removing and installing the battery

You can charge your battery either on or off your RadTrike. If you remove it for charging, storage, transportation, security, or some other reason, keep these procedures to prevent battery damage.

BATTERY REMOVAL

To remove the battery, turn its key to the off and unlocked position (see [“Start-up procedure” on page 24](#)) and remove the key from the keyport. Carefully pull the battery forward and up until the battery detaches from the battery mount.

NOTICE: When the battery is off its mount, protect the battery terminal contacts from damage or exposure to harmful substances including liquids and salt. Do not touch the terminal contacts. If the terminals become damaged, please discontinue use and contact Rad Power Bikes Product Support immediately.

BATTERY INSTALLATION/MOUNTING

1. **Make sure the battery keyport is in the “power off/unlocked from frame” position.** Remove the key.
2. **Align the notches on the back of the battery between those in the battery mount.** Slowly slide the battery down until it's secure. Do not force the battery into the battery mount.
3. **Lock the battery to the frame.**
4. **Test the security of the battery by carefully pulling up on it with both hands.** The battery should not move during this test.

Before you charge

NOTICE: Failure to follow the battery-charging best practices outlined in this manual could result in unnecessary wear to the battery and/or charger, and could lead to an underperforming or non-functional battery. Batteries damaged due to improper care will not be replaced under warranty.

Check for hazards. Before you charge your battery, make sure to first check the battery, charger, and electrical cables for signs of damage. Check the battery mount terminals for signs of dirt and leakage. Store and use the charger in a safe place—away from children, direct sunlight, dirt, debris, tripping hazards (including electrical cords), or any materials that could ignite in the unlikely event of a charger or battery malfunction. Position the charger and battery where they're not at risk for falls or other impacts.



WARNING: Letting a battery charge unattended increases the risk that a charging problem will go undetected and lead to component damage or a fire hazard. Always charge your battery where you can monitor it.

Ensure the ambient temperature is appropriate. For best charging performance and to minimize wear and tear on components, we recommend charging at ambient temperatures of 41°F to 77°F (5°C to 32°C). Your battery generates heat while charging, but it's designed to air-cool, so keep it uncovered with the light facing upward on a flat, stable, hard, unheated surface. At relatively low temperatures, charging can take longer.

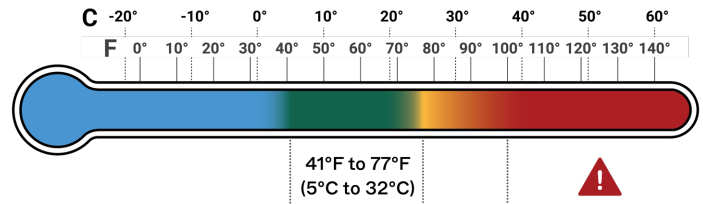

CAUTION: Do not charge your battery when it is warm from riding or in ambient temperatures above 100°F (38°C) to prevent unnecessary wear and tear on battery and charger. If the battery has turned off to prevent heat damage, wait until the battery cools down to turn the battery back on. Never charge your battery on or near heat-generating devices.



WARNING: Charging your battery with a charger other than one supplied by Rad Power Bikes and designed for your specific trike serial number can cause damage to your trike's electrical system or create a safety hazard. Only use a battery charger designed for your trike and supplied by Rad Power Bikes.



WARNING: Letting a battery charge unattended increases the risk that a charging problem will go undetected and lead to component damage or a fire hazard. Always charge your battery where you can monitor it.



WARNING: Using a damaged battery or charger can damage additional components or create a fire hazard. Stop using your battery and charger and contact Rad Power Bikes immediately if any of the following occur: (1) Your charger's flexible power cord or output cable or any of the electrical cables on your trike is frayed, has broken insulation, or any other signs of damage, (2) Your battery or charger is physically damaged, non-functional, or performing abnormally, (3) Your battery or charger experienced a significant impact from a fall, crash, or shipping damage, with or without obvious signs of damage, (4) Your battery was submerged in liquid or had extensive water exposure or damage, or (5) Your charger becomes too hot to touch (it's designed to get warm with normal use), makes an unusual smell, makes a popping sound, or shows other signs of overheating. Store any damaged battery or charger in a safe location away from the house and other structures and, as soon as possible, recycle or otherwise dispose of it according to local rules. Contact Rad Power Bikes Product Support if you have any questions. Replacement batteries and chargers are available at radpowerbikes.com.

Charging procedure

To charge your battery, mind the advice in [“Before you charge” on the previous page](#) and then follow these steps.

1. **Turn the power off.** Press and hold the power button on the UI Remote until the display turns off. If desired, use the key to unlock and remove the battery from the trike frame. The battery can be charged either on or off the trike.
 - To charge the battery while it's **on** the RadTrike: align the key with position B in the “Keyport and Key Positions” illustration.
 - To charge the battery while it's **off** the RadTrike: align the key with position C in the illustration. Make sure to remove the key from the battery, and then remove the battery from the trike.

KEYPORT AND KEY POSITIONS

	Description
A	Power on , battery locked to frame
B	Power off , battery locked to frame
C	Power off , battery unlocked from frame (for battery installation and removal)

2. **Locate the charging port of the battery.** The charging port is on the opposite side of the battery from the keyport. Note that the charging port includes a cover; the keyport does not have a cover.
3. **Place the charger on a flat, secure surface if you have removed it from your trike.** The charging indicator light should face up.
4. **Plug the charger into the battery charging port.** Open the flexible cover on the charging port. Connect the charger's round barrel connector to the charging port on the side of the battery.
5. **Plug the charger into a power (wall) outlet.** Charging should initiate and will be indicated by the LED on the charger turning green (to indicate power source connection) and then immediately turn red to indicate active charging. When charging is complete, the LED will turn green again.
6. **When charging is complete, unplug the charger from the power (wall) outlet, and then unplug it from the battery.** Be sure to pull gently on the plugs, not on the cables themselves.

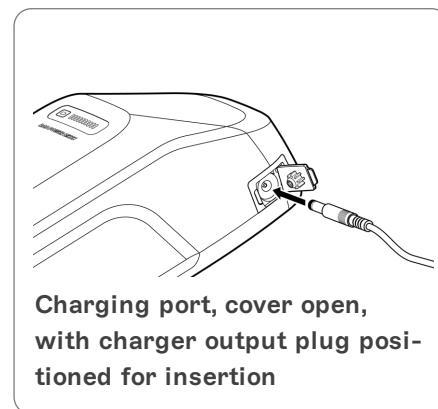
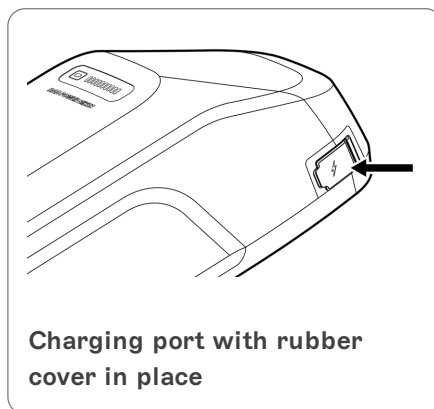

NOTICE: The charger is designed to stop charging automatically when the battery is full. Store the charger carefully, making sure its plug does not come in contact with liquids, dirt, debris, or metal objects, which can damage the plug and interfere with future operation.

Estimated charging times

The time needed to fully charge your battery depends on its age, how far it was used to travel, the nature of that travel (terrain, payload, PAS and throttle use, etc.), and other factors. The table here provides a rough estimate of charge time based on distance traveled. Charging at low temperatures can increase recharge time.

NOTICE: The battery may take longer to charge when fully depleted, when very new, and after 3–5 years of regular use. If your battery doesn't seem to be charging normally, is taking longer to charge than expected, or you're experiencing substantial reduction in range, discontinue use and contact Rad Power Bikes Product Support.

Distance	Recharge time
5 mi (8 km)	1 hour
10 mi (16 km)	2 hours
15 mi (24 km)	3 hours
20 mi (32 km)	4 hours
25 mi (40 km)	5 hours
30 mi (48 km)	6 hours

Estimated range per full charge

We suggest that you select a lower PAS level when you're getting to know your RadTrike and travel routes. Once you become familiar with your range requirements and the capabilities of your trike, you can adjust your riding characteristics.

The table in this section provides range estimates to help you understand the factors that can increase or decrease range. Rad Power Bikes makes no claims about the range that individual users might experience in a particular situation.

20 mi (32 km):	<ul style="list-style-type: none"> • Hilly terrain • Windy 	<ul style="list-style-type: none"> • Light pedaling • Heavy payload 	<ul style="list-style-type: none"> • High pedal assist level
28 mi (45 km):	<ul style="list-style-type: none"> • Flat terrain • Not windy 	<ul style="list-style-type: none"> • Light pedaling • Normal payload 	<ul style="list-style-type: none"> • Low pedal assist level
35 mi (56 km):	<ul style="list-style-type: none"> • Flat terrain • Not windy 	<ul style="list-style-type: none"> • Moderate to heavy pedaling • Normal payload 	<ul style="list-style-type: none"> • Low pedal assist level

Best practices for extending range and battery life

Follow the best practices listed below to help extend your range and battery life.

- Whenever possible, avoid applying full throttle when the RadTrike has slowed to very low speeds, has stalled, or stopped.
- Pedal to assist the motor when climbing hills and accelerating from a stop.
- Do not climb hills steeper than 15% in grade.
- Avoid sudden starts and stops.
- Accelerate slowly.
- Avoid riding in extremely cold or hot temperatures.

Battery storage

If storing your trike from Rad Power Bikes for longer than two weeks at a time, follow the recommendations below to maintain the health and longevity of your battery.

- Power off the battery either locked to the frame or unlocked and removed from the frame for storage. (see [“Start-up procedure” on page 24](#) for key-position details.)

STORAGE TEMPERATURES

Store the battery in a dry, indoor location between 14°F to 77°F (-10°C to 25°C).

CAUTION: Long-term storage of your battery at temperatures above 95°F (35°C) or below 40°F (5°C) can reduce battery performance and lifespan.

DANGER: Storing your battery above 131°F (55°C), such as in a hot car in direct sunlight, can cause permanent range decline or critical failure, and could lead to electrical fire, serious injury, or death.

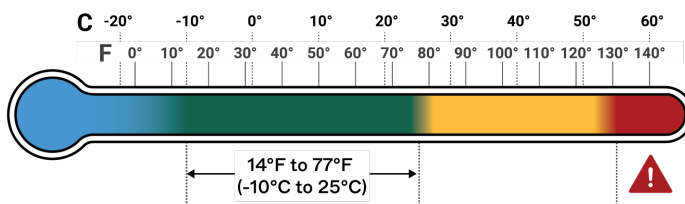

STORAGE:

Recommended temperature range

LONG-TERM STORAGE

- For long-term storage, we recommend that you keep your battery at approximately 40-70% charged. Check the battery's charge level monthly. If necessary, use the charger from Rad Power Bikes to charge the battery to about 40-70% charged.

CAUTION: Don't store your battery long-term at full charge, zero charge, or very little charge. Storing your battery for long periods at *full charge* can cause range decline over time. Storing your battery for long periods at *very little or no charge* can cause permanent range decline or a non-functional battery.

Summary: Battery recommended temperatures

The temperatures listed below represent *ambient* temperatures. Internal battery temperatures are likely to be higher than ambient temperature during charging and use. The battery will automatically turn off to prevent damage when its internal temperature reaches below 5°F (-15°C) or above 131°F (55°C). Please see the preceding sections for more information.

Recommended operation (riding) range: 5°F to 105°F (-15°C to 40°C)

Recommended charging range: 41°F to 77°F (5°C to 32°C)

Recommended storage range: 14°F to 77°F (-10°C to 25°C)

Additional critical battery safety information

You must read and understand all safety-related messages in this section before handling, using, charging, or storing the battery that came with your RadTrike.

- Always remove the key from the keyport of the battery before riding. Do NOT operate the trike with the key in the keyport, or injury to your leg or damage to the electrical system can occur.
- Avoid salt water and de-icing compounds, which are very corrosive and can lead to damage, especially if they come in contact with the battery and its mount. Never ride through standing salt water, e.g., through waves at a beach.



DANGER: Never open the battery housing, which can expose you to caustic substances and electrical shock. It can also create a fire hazard, which can lead to serious injury or death. Opening the battery housing may void the warranty.



WARNING: Never immerse or submerge the battery in water or liquid, including water in the battery mount, which can cause damage, serious injury, or death. If the battery was immersed or submerged in water or another liquid, do not use the battery.



CAUTION: Using aftermarket battery accessories or products that have not been tested by Rad Power Bikes for safety and compatibility may void your warranty, result in trike or property damage, create a safety hazard, or cause injury. If you use products not tested and recommended by Rad Power Bikes, you do so at your own risk.



CAUTION: To reduce the risk of fire, connect only to a circuit provided with 10 amperes maximum branch circuit overcurrent protection in accordance with the National Electrical Code, ANSI/NFPA 70.

NOTICE: When the battery is off its mount, protect the battery terminal contacts from damage or exposure to harmful substances including liquids and salt. Do not touch the terminal contacts. If the terminals become damaged, please discontinue use and contact Rad Power Bikes Product Support immediately.

NOTICE: Always follow any safety information attached to the battery or charger. A sample label for the battery that shipped with your trike is shown at right, manufacturing location and other details may differ. Do not remove this label from the battery.

ATTENTION

The battery **MUST** be locked into the frame mount before use.
Ensure the battery and charger are not damaged before charging.
Do not connect the positive and negative terminals of the battery pack.
Do not expose the battery to high temperatures.
Ensure the battery charger is unplugged from the battery pack and put away before you ride.
For best performance always charge your battery in temperatures between 10 and 25 degrees Celsius (50 and 77 degrees Fahrenheit).
Do not subject the battery to salt water or leave the bike in the rain for extended periods.
Only use original equipment for charging.

Model - RAD - FE - S1302R 131NR22 / 71-2
Patent Pending | Made In China - PYTES
Designed in Seattle by **RAD POWER BIKES™**
RATING: 48v === 480Wh

Operation



WARNING: Incorrect assembly, maintenance, or use of your trike can cause component or performance failure, loss of control, serious injury, or death. Even if you're an experienced bike rider, **you must read and understand the entire manual and any documentation provided for subcomponents or accessories before riding.** If you are not sure you have the experience, skills, and/or tools to correctly perform all assembly steps in the manual and the assembly video at rad-go.com/trike, have a local, professional, reputable bike mechanic assemble your trike.

How the electrical system works

Your RadTrike is equipped with two ways for a rider to use power assistance from the motor forward: a pedal assist system (PAS) and a twist throttle. In addition, the PAS "R" (for reverse) mode lets you use the throttle to move backward.



WARNING: Practice using the pedal assist (PAS) and throttle in a flat, clear, open area until you understand how these power sources work together. Failure to understand how to safely operate the PAS and throttle together can result in loss of control, crash, injury, and/or death.

HOW PEDAL ASSIST WORKS

You can use the pedal assist system (PAS) to call up assistance from the motor *while you are pedaling*.

Pedal assist uses a cadence sensor built into the drivetrain of the trike. The cadence sensor detects when you revolve the pedals and signals the electric motor to provide the level of pedal assistance (0-5) that you selected. Each PAS level has a top speed at which the motor will stop providing power.

	PAS top speed	Throttle top speed
PAS R	n/a	2.7 mph (4.2 km/h)
PAS 0	n/a	14 mph (22.5 km/h)
PAS 1	2.7 mph (4.3 km/h) max	14 mph (22.5 km/h)
PAS 2	5.0 mph (8.0 km/h) max	14 mph (22.5 km/h)
PAS 3	7.0 mph (11.3 km/h) max	14 mph (22.5 km/h)
PAS 4	10.0 mph (16.0 km/h) max	14 mph (22.5 km/h)
PAS 5	14.0 mph (22.5 km/h) max	14 mph (22.5 km/h)

HOW THE THROTTLE WORKS

The throttle is located on the right side of the handlebar. Twist it to propel the trike forward or backward without pedaling. Once you release the throttle or apply the hand brake, the throttle will no longer propel the trike.



CAUTION: Do not use the throttle and the foot brake at the same time. Using the foot brake will not cut power to the motor, so using the throttle and the foot brake at the same time will place unnecessary strain on your drivetrain and motor, potentially damaging components.



NOTICE: Throttle and motor use may not be allowed in all areas. It is your responsibility to know and follow local ebike regulations, rules, and traffic laws where you ride.

THROTTLE BEHAVIOR BASED ON PAS LEVEL

Forward (PAS 0-5): To engage the throttle while riding to propel the trike forward, select a PAS level between 0-5. Slowly and carefully rotate the throttle toward yourself. The more you twist, the more powerfully the motor will propel the trike forward. The throttle has a max speed of 14 mph in each PAS level between 0-5.

REVERSE MODE (PAS R)

The RadTrike comes with a reverse mode to allow you to propel the trike backward. Reverse mode is especially useful if you do not have enough room to turn. To engage the reverse mode, follow these steps.

1. Release the throttle and use the hand brake or coaster brake to come to a complete stop.
2. Press the down arrow button on the Rad UI Remote to move to PAS 0.
3. Hold the down arrow button for two seconds. Once reverse mode is selected, the remote will display a lowercase "r."
4. Rotate the throttle slowly and carefully to start moving in reverse. The throttle has a max speed of 2.7 mph in reverse mode. Rest your feet on the pedals without pushing them. Pedaling forward while in reverse will not engage the PAS.
5. To exit reverse mode, simply press the up or down arrow buttons on your Rad UI Remote.

- CAUTION:** Keep your feet on the pedals and your body weight centered any time the trike is in motion. Placing your feet on the ground could cause the wheels to contact your feet or legs, potentially resulting in injury.
- CAUTION:** Always look behind you for objects and obstacles before propelling the trike in reverse. Failure to check your surroundings can lead to trike damage or injury. We recommend supplementing your rear vision with mirrors, which are available at radpowerbikes.com.
- CAUTION:** Carrying cargo significantly affects riding in reverse, which can increase the risk of falls and other accidents, property damage, or injury. To minimize risk, practice riding in reverse in a flat, open, and safe area before adding cargo.

NOTICE: Throttle and motor use may not be allowed in all areas. It is your responsibility to know and follow local ebike regulations, rules, and traffic laws where you ride.

Handlebar features

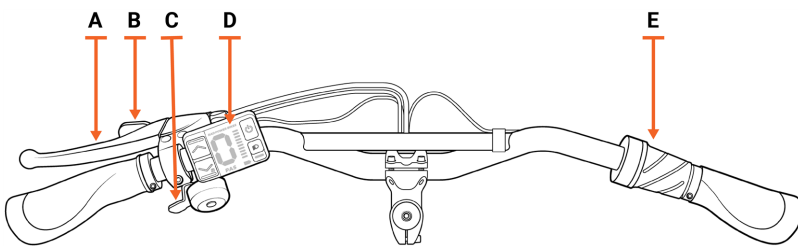

A	Left brake lever (for front brake)
B	Parking brake
C	Bell lever
D	Rad UI Remote
E	Throttle

Rad UI functions and electrical controls

RAD UI REMOTE

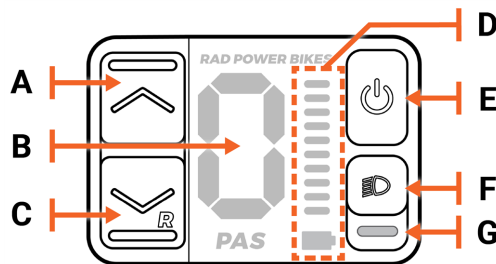

A	Up Arrow
B	PAS (pedal assist system) Level
C	Down Arrow (and Reverse Mode)
D	Battery Level (can also display error codes)
E	Power Button
F	Headlight button
G	Headlight-on indicator

Using the Rad UI Remote (above) and other trike features, you can power your trike on or off and control other electrical functions.

Power	Power on/power off	Press and release the power button.
	Skip "rAd" sequence at startup	Press and release the Up Arrow or Down Arrow.
	Power save timer	When powered on, the UI will power off automatically after 5 minutes of inactivity.

Lights	Lights at startup	Headlight, taillight, and display backlight will turn on automatically when the trike is powered on.
	Turn on headlight/taillight	When the trike is powered on and the headlight is off, press and release the headlight button.
	Turn off headlight/taillight	While powered on, to turn off the headlight for daytime riding (which is optional), press and release the headlight button.
	Headlight indicator light	This light is located below the headlight button on the Rad UI Remote and will be illuminated when the headlight is on.
	Brake light	See “Brake light” on the next page
Pedal assist system (PAS)	Increase pedal assist one level	Press and release the Up Arrow on the Rad UI Remote.
	Decrease pedal assist one level	Press and release the Down Arrow on the Rad UI Remote.
Battery charge level	Battery level indicators on the UI Remote	On the UI Remote, 10 light bars.
	Battery level indicators on the battery	On the battery, 10 light bars (see page “Battery information” on page 15).

Brake features

The RadTrike is equipped with three brake features. Use the front brake and the coaster brake to slow and stop the trike. To prevent the trike from rolling when parked, engage the parking brake, which locks the front brake.

THE FRONT BRAKE

The front brake is located on the left handlebar. To operate the front brake, squeeze the brake lever. The front brake is a cable-actuated disc brake and is the most common type of brake found on bikes. When you squeeze the brake lever, a motor-cutoff sensor will stop all power from the motor.

WARNING: Using the front brake by itself, especially at significant speeds, can cause excessive stress on components, damage to the trike and parts, loss of control, injury, or death. Always apply the rear coaster brake (operated by pedaling backward) before applying the front brake. Use both brakes together.

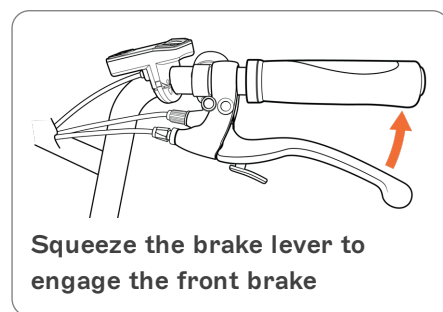

THE REAR COASTER BRAKE

Engage the rear coaster brake by rotating the pedals backward. The coaster brake will stop the rear wheels from turning.

CAUTION: The coaster brake does not include a motor cutoff. Do not attempt to operate the throttle while using the coaster brake, which will interfere with braking and will needlessly strain or damage the brakes, motor, and other drivetrain components.

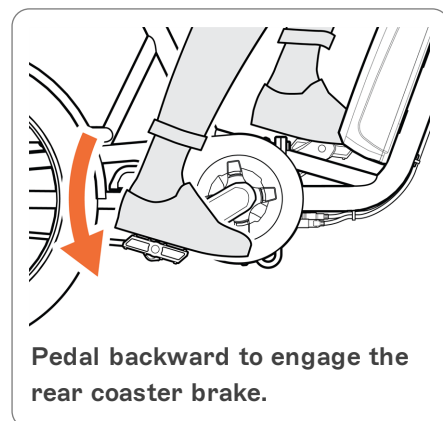

THE PARKING BRAKE

The parking brake is located on the front brake lever. To engage the parking brake, bring your trike to a complete stop. Squeeze the front brake lever, and then pull the orange lever with your index finger until it clicks into place. To release the parking brake, squeeze the front brake lever until the parking brake releases.

Brake light

The RadTrike is equipped with a taillight/brake light that is integrated into the electrical system. When you turn on your trike, both the headlight and taillight will illuminate to make you more visible to other vehicles. Any time the trike is powered on, squeezing the hand brake lever will activate the brake light, causing the taillight to illuminate additional areas.

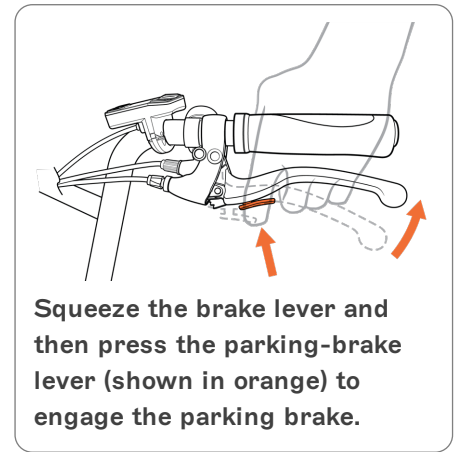

Start-up procedure

Before you can take your first ride you need to have properly assembled your trike, tightened all components correctly, read this entire manual, and had a professional, reputable bike mechanic check the assembly. You also need to be at least 16 years old, and don't forget to put on a helmet.

Follow these steps to ride Rad!



1. **Run through the safety checks** outlined in [“Safety checklists” on page 31](#)

2. **Familiarize yourself with the key positions.** The [“Keyport and key positions”](#) illustration shows the key-port in position B, in line with the small circle icon with an “X” through it. In key position B, the battery power is off and battery is locked to the frame.

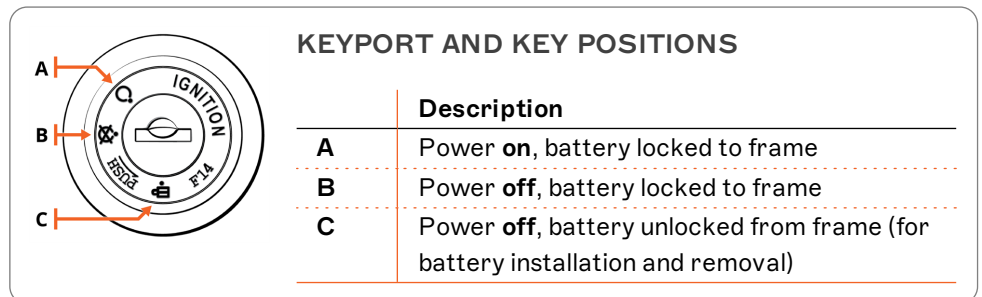

3. **Check that the battery is locked securely.** Ensure the keyport is aligned with the circle containing an “X,” in the “Power off, battery locked” position (B) as explained above. If needed, insert the key and align with the “Power off, locked” icon (B). Remove the key and carefully use both hands to pull up on the battery to test that the lock is secure.



CAUTION: Getting onto the trike or riding it with the key in the battery can cause injury to your leg and damage to the key or lock mechanism. Always remove the key before riding the trike.

4. **Turn on the trike.** With the battery locked in place, insert the key and turn clockwise to the open circle icon, which is the “Power on, battery locked to frame” position (A), as shown in the image above. Remove the key by pulling directly backward without twisting so the key position remains in the “Power on, battery locked to frame” position. Locate the Rad UI Remote (near the left handlebar grip). Press the power button for about two seconds until the Rad UI Display and the Rad UI Remote turns on (the UI Remote will spell out “rAd”).



CAUTION: Do not confuse your keyport and the charging port. Do not insert your key into the charging port. Inserting anything into the charging port other than the charging plug can damage the battery.

5. **Try out your bell** if you haven't already! It's an important safety tool for alerting others to your presence, especially when passing. The bell is integrated into the left brake lever on your handlebar. To ring it, flick the bell lever; see the illustration [“Handlebar features” on page 22](#).

6. **Keep your feet on the pedals and your body weight centered when riding.**



WARNING: Never place your feet on the ground when the trike is in motion. Doing so can cause the rear wheels to hit your feet or legs, hurting you or potentially causing an accident that could lead to serious injury or death. Keep your feet on the pedals whenever the trike is in motion.

- 7. Begin riding carefully.** With the proper safety gear and rider knowledge, you may now operate your trike from Rad Power Bikes. Start pedaling on flat ground, clear of obstacles and people, with the trike at pedal assist level 0 or 1.

NOTICE: While you're getting to know your trike, don't ride with cargo (see ["Carrying cargo" on page 29](#) for more information). Review, understand, and follow the safety information in ["Ride as safely as possible" on page 41](#).



WARNING: Engaging the pedal assist feature, especially at a high setting, will cause acceleration that may be greater than expected, especially for relatively new riders, and that can cause loss of control, serious injury, or death. To minimize risk, start at PAS level 0 or 1.

Turning and maneuvering

Operation of the RadTrike differs from the operation of bikes with two wheels. Follow the tips in this section to ensure a safe riding experience.

- Do not attempt to turn the trike at high speeds. Slow the trike down below 5 mph (8 km/h) while turning to prevent loss of balance. Do not pedal or use the throttle while turning.
- Turn the handlebar gently, leaning slightly toward the turn to maintain stability.
- Never put your feet down while moving.
- Take extra caution when turning on uneven surfaces. Ensure any cargo is secured and centered.
- Slow down when maneuvering in tight spaces or around other riders, cars, or vehicles. The trike is significantly wider than most two-wheeled bikes. Be aware of your surroundings and your wheelbase at all times. Practice riding near objects safely until you understand how to account for the rear wheel path.
- When walking alongside the RadTrike, place one hand on the handlebar and the other on the seat back for stability. Pay close attention to where the wheels are to avoid accidents and injuries while walking with the trike in tight spaces.

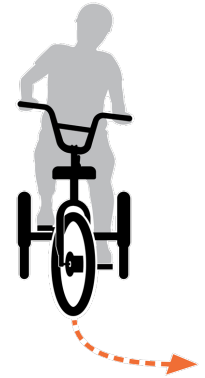

Lean slightly toward a turn



WARNING: Failure to follow these steps may result in accidents, property damage, serious injury or death. Practice turning and maneuvering in an open area, away from traffic.

Riding on hills

Use extreme caution when riding the trike on hills. Increased grades will affect the trike handling significantly. Always control your speed and give yourself extra time and distance to maneuver the trike. Do not ride up or down very steep hills (about 10-15% grade or more depending on your payload and readiness to pedal).

RIDING UPHILL

Your RadTrike is designed to climb hills, but how steep you can climb will depend on many factors including how much you pedal, how much weight is on your RadTrike, how weight is distributed on your trike, and surface conditions. Follow these guidelines when riding uphill:

- Help your motor by pedaling. The steeper the hill and the more weight you are carrying, the more important this is for maintaining speed and decreasing strain on your motor. If you place too much strain on your motor under any conditions, your motor will stop providing power in order to prevent damage.
- If you need to improve the traction of your motorized front wheel, lean forward to put more weight on that wheel.



Mind the width of the back wheels

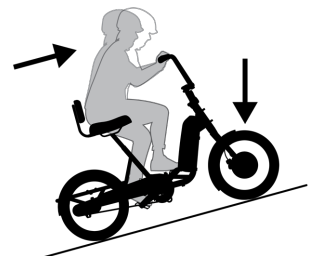

Leaning forward can improve front-wheel traction

RIDING DOWNHILL

Use extreme caution while riding downhill. Although the pedal assist system will stop providing motor power when you hit the PAS-specific speed limit (see [“Operation” on page 21](#)), you can still go faster than those limits by pedaling or cruising downhill. Do the following to stay safe:

- Control your speed using *both* the hand brake and the coaster brake *together*.
- If you must turn, slow down as much as possible and then turn gradually, not sharply.
- Any time you are riding at speed, with extra weight, or in slippery conditions, braking will take longer. Plan accordingly.



WARNING: Failure to control speed or turning sharply while going downhill increases your risk of losing control of your trike, which can lead to serious injury or death.

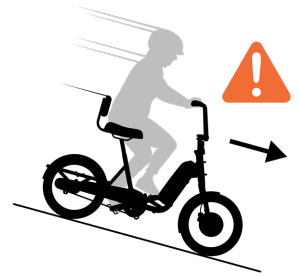

Control your speed when riding downhill

RIDING ACROSS A SLOPE

Avoid riding across slopes, which will tilt your trike and may increase your risk of tipping. If you must ride across a slope, do so on gentle slopes only. Use extreme caution when turning, especially uphill, and do NOT lean downhill.

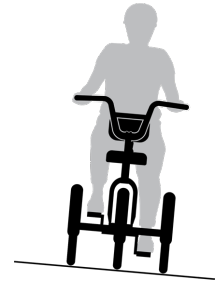

Gentle slopes only!

Folding and unfolding your RadTrike's stem riser

The RadTrike may come with one of two folding stem-riser designs. Follow the directions for your stem riser.

NOTICE: Use caution to keep fingers, clothing, and other objects away from the folding mechanism and potential pinch points on your trike. Always check the folding mechanism to ensure it's locked before you ride or move your trike.

Follow the procedures below to fold and unfold your RadTrike's stem riser.

FOLDING

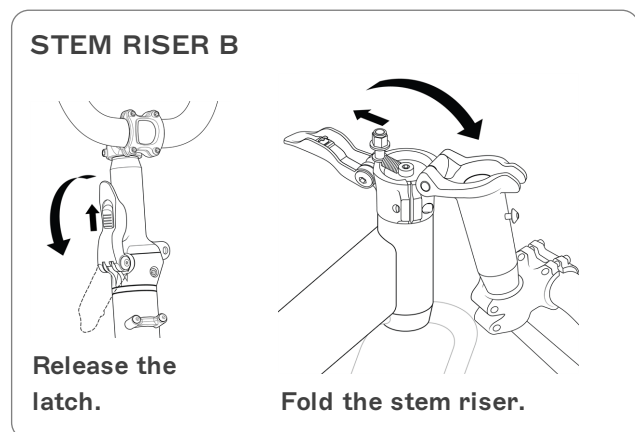
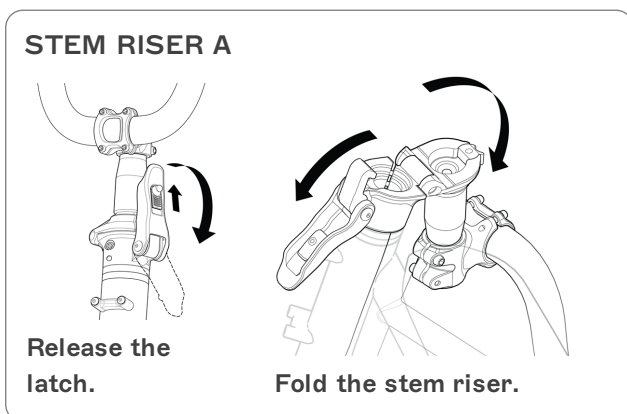

1. **Stand on the side of the trike** that allows you to see the folding mechanism clearly.
2. **Press upward on the release button in the center of the locking lever** (see illustration). While the button is pushed all the way up, pull down on the locking lever until it comes to rest roughly parallel with the stem. The stem will still be locked. At this point, use one hand to steady the handlebar before you start to fold the stem.

3. **Push the locking lever down further** to ensure the latch bolt releases the top part of the stem riser (see illustration). The locking mechanism will be fully open now.
4. **Gently fold the stem riser** so that the handlebar rests against the bike frame.

UNFOLDING

Reverse the folding steps listed above. Be sure that you press the locking lever all the way toward the stem riser and that the release button clicks back up and into place.

 **WARNING:** Riding your trike with the locking mechanism not fully secured can cause damage to the trike, serious injury, or death. Before each ride, check to ensure that the locking mechanism is fully closed and locked. .

Parking, storage, and transport

Please follow these tips to ensure your trike is well cared for when you're not using it.

PARKING AND STORAGE

- Park in accordance with local rules and regulations, especially if you're in a public place.
- Park indoors whenever possible. If you must park outdoors in rain or wet conditions, do not do so for an extended period of time, and afterward park in a dry location to allow the trike systems to dry out. When any bike or trike is exposed to wet conditions, it will need more frequent maintenance to prevent rust and corrosion and to ensure all systems work safely. See [“Guard against rust, corrosion, and water damage” on page 38](#) .
- Avoid parking or storing your trike in direct sunlight, which can cause damage to electrical components.
- Do not park or store your trike in excessive heat, such as inside of a parked car on a hot day. Always store your trike within this temperature range: 14°F to 77°F (-10°C to 25°C).

 **DANGER:** Storing your battery above 131°F (55°C), such as in a hot car in direct sunlight, can cause permanent range decline or critical failure, and could lead to electrical fire, serious injury, or death.

- Register your trike with [BikeIndex](#), [529 Garage](#), or a regional bike registry (ask your local bike shop for recommendations) to increase the chance you'll get your trike back in the unfortunate event it's stolen.
- Lock up your trike to reduce risk of theft. You can purchase a lock from our website at [radpowerbikes.com](#) or consult a local bike shop.

TRANSPORTING

- When pushing or carrying the trike, turn off the power to avoid accidental acceleration from the motor, e.g. by mistakenly twisting the throttle.
- Do not leave a battery in direct sunlight or any location that is or may become excessively hot or cold, like a parked car, for extended periods.
- Before using public transportation (buses, trains, etc.) to transport your trike, check with the relevant transportation authority for rules that might apply to trikes, including weight and size limits, tire widths, lithium-ion batteries, etc.
- Avoid transporting any electrical bike or trike on a vehicle rack or truck bed during rain, which may cause water damage to the electrical components. See [“Guard against rust, corrosion, and water damage” on page 38](#) for more information. In any weather, it's safest to remove your battery before transporting your trike. Carry the battery inside the vehicle, carefully placed to protect it from impacts, dirt, liquids, or other hazards.

FITTING YOUR RADTRIKE INTO A CAR

If you need to fit your RadTrike into a car (a van, station wagon, hatchback, etc.), here are some tips that can help:

1. **Measure your vehicle** to determine if the RadTrike will fit. If you fold the handlebar down and remove the seat, the RadTrike will be about 60 inches long, 33 inches wide, and 29 inches high.
2. **Engage the parking brake and remove the battery.** Press the power button to discharge any remaining power.
3. **Remove the seat/seatpost** from the Trike to minimize its height.
4. **Fold down the handlebar** as explained in [“Folding and unfolding your RadTrike's stem riser” on the previous page](#) if you need to minimize the RadTrike's height.

5. **Optional:** If you need to make your RadTrike even more compact, you can separate the front of the RadTrike from the back as follows:
- Prop the center of the RadTrike frame on something sturdy**, like some books, to ensure your frame stays stable while you separate it.
 - Disconnect the three cables that connect beneath the center of the frame.** This may require snipping a zip tie.
 - Remove the two upper bolts from the frame connection point.**
 - Loosen the two lower bolts from the frame connection point.**
 - Lift the front half of the connection point up and off the two lower bolts.** (See the illustration.) Set the front half of the frame down gently, taking care not to pinch any cables.
 - Replace the bolts onto the back half of the frame connection point** so they're easy to find when you're ready to reassemble.
 - Pack everything you will need to reassemble the RadTrike when you're ready to ride again.** Tools you'll need include the wrench for the frame connection point bolts, a torque wrench and an appropriate Allen bit to torque those bolts, a zip tie to re-secure the cables, and something to prop up your frame connection point while you reassemble.
6. **Carefully place your RadTrike into your vehicle.** Get help from a strong friend or two.
7. **If you previously separated the two halves of your RadTrike, reassemble it when you're ready to ride again.** Re-secure the frame connection point with the four bolts, reconnect the three cables, and secure those cables with a zip tie. Follow the directions and safety advisories in ["Assembly instructions" on page 4](#) and be sure to torque your frame connection point bolts to the value listed in ["Tools and torque specifications" on page 11](#).

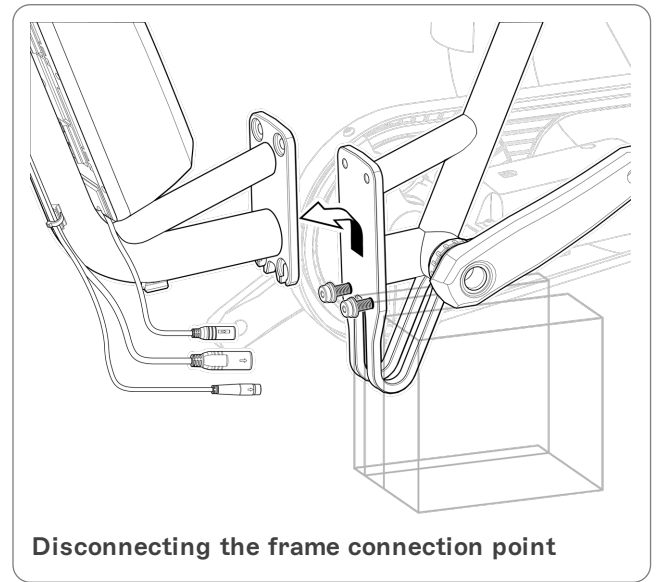



Carrying cargo

Carrying cargo can help you have more fun on your trike and replace trips you'd otherwise make with a car, which we think is rad. It also involves additional risks. You must read and understand this entire chapter and the rest of the manual plus any documentation that comes with any accessories you purchase before you ride your trike with cargo.

Rad Power Bikes provides a wide range of accessories to make it easier to carry cargo. **Your RadTrike is not designed to carry passengers, and its rear rack is not compatible with the Thule Yepp child seat. Do not allow anyone to ride, sit, or stand on the rear rack.**

For more information on optional accessories for your trike, please go to radpowerbikes.com.

 **DANGER:** Only one person—the operator—should be on the RadTrike at a time. Transporting a passenger (any person in addition to the operator) on the RadTrike can result in serious injury or death to either or both the operator and the passenger. The RadTrike is not designed for carrying passengers, and its rear rack is not compatible with Thule Yepp child carriers.

 **NOTICE:** Carrying a passenger, child, or cargo may not be allowed in all areas. It is your responsibility to know and follow all applicable laws where you ride your trike.

Weight limits

The total maximum carrying capacity of the RadTrike, listed below, includes the weight of the rider as well as clothing, riding gear, cargo, accessories, etc. Always use the parking brake and hold onto the trike when cargo is being loaded or in place. Any optional accessories listed below are available for purchase at radpowerbikes.com

Total carrying capacity of the RadTrike: 475 lb (215 kg)

Maximum rider weight: 325 lb (147 kg)

Rear rack maximum capacity: 60 lb (27 kg)

Optional front rack maximum capacity: 30 lb (14 kg)

The maximum payload capacity and other important safety information for specific Rad Power Bikes accessories will come with those products and/or be available online at radpowerbikes.com/help.

 **WARNING:** Never exceed the payload limit of any accessory or component of your trike even if you attach to it an accessory that carries a higher weight limit. Overloading any component can cause component failure, loss of control, serious injury, or death.

 **WARNING:** Failure to ensure that cargo can't interfere with the operator's control of the trike can lead to serious injury or death. The operator is always responsible for securing loads, loose straps, and gear.

 **CAUTION:** Loading cargo on the trike can cause the trike to roll forward or backward or tip over, leading to damage or serious injury. Always hold on to your RadTrike and/or set the parking brake when loading or unloading cargo.

Carrying loads (cargo) safely

Follow these instructions to maximize safety when using your RadTrike to carry cargo.

LOAD AND SECURE CARGO CAREFULLY

- Use the parking brake and hold onto the trike when loading cargo.
- Load cargo as low as possible to keep the trike's center of gravity low and improve stability.
- Ensure cargo loads are properly secured and periodically check that nothing loosens, risks interfering with any moving parts, or risks touching or dragging on the ground.

 **WARNING:** Failure to ensure that cargo can't interfere with the rider's control of the trike can lead to serious injury or death. The rider is always responsible for securing loads, loose straps, and other items.

PRACTICE WITH LIGHT LOADS IN A SAFE AREA

Carrying extra weight significantly affects braking, acceleration, turning, balancing, etc. These effects can be increased by challenging riding conditions, such as when roads are wet or slick. Hills that are normally easy to climb or descend without cargo can become challenging or even dangerous once extra weight is loaded onto the trike.

Extra weight will also increase the time it takes to slow the trike when braking.



WARNING: Carrying cargo significantly affects braking, acceleration, turning, and balancing, which can increase the risk of falls and other accidents, potentially leading to property damage, serious injury, or death. To minimize such risk, practice riding with light cargo in a flat, open area before attempting to carry heavier cargo, especially on roads or hills and in wet conditions.

USE BOTH BRAKES

With extra weight on your trike, it's more important than ever to use both front and rear brakes, and always engage the rear brake first to prevent excessive strain on the front wheel and fork and to prevent loss of control. Ensure both front and rear brakes are properly adjusted, maintained, and applied.



WARNING: Using the front brake by itself can cause excessive stress on components, damage to the trike and parts, loss of control, injury, or death. Always apply the rear brake before applying the front brake, using both brakes for all operations.

ADJUST YOUR ROUTES AND SPEED

When carrying heavy loads, plan your routes to avoid challenging hills and other hazards. Ride more slowly, and leave more time and distance for braking.

Carrying pets

Rad Power Bikes understands that you may want to bring your pet along on your trike adventures, and we think that's rad. We urge you to take great care to protect your furry friend and yourself. To check out the pet accessories that we have tested for safety and compatibility with our ebikes, please visit radpowerbikes.com. We cannot recommend any pet carrier or restraint system that we have not tested for compatibility and safety with your trike from Rad Power Bikes.



WARNING: Transporting a pet using any bike or trike puts you and your pet at risk of injury or death, especially if the pet distracts you, affects your balance, interferes with moving trike parts, or causes you to exceed your trike's or a component's maximum weight capacity, etc. It's impossible to anticipate every situation that can occur while riding with a pet. If you carry a pet on any bike, trike, or similar vehicle, you assume any and all inherent risks.



WARNING: The trike operator is always responsible for assessing a pet's ability to ride safely. Using this product to transport a pet who does not have the health and temperament to ride safely can lead to serious injury or death of the operator and/or pet(s). Consult a veterinarian or pet behavior specialist if you have any questions or concerns.



WARNING: Never leave a pet unattended in a pet basket carrier or other appropriate pet accessory on the trike. Leaving pets unattended on the trike creates a VERY HIGH RISK of the pet trying to escape or the trike tipping over, leading to damage, serious injury, or death.

Safety checklists



WARNING: Any bike, trike, or similar vehicle is subject to wear and tear, and certain components and fasteners can stretch or loosen with the vibrations and stress of normal operation. **You must check your trike before each ride** and according to the other checklists in this manual. Failure to do so could result in property damage, serious injury, or death.



PRE-RIDE CHECK
rad-go.com/safety

BEFORE YOUR FIRST RIDE

- Make sure handlebar cables were routed correctly when the handlebar was installed. Turn the handlebar fully to the left and right and make sure this doesn't pull any of the cables or wires taut.
- Make sure your pedals are secure using a pedal wrench or a torque wrench fitted with a crowfoot bit. Torque according to the values listed in [“Tools and torque specifications” on page 11](#).
- Check that the cable connectors on the trike are all plugged in securely and that nothing loosened in shipping.
- Check the brake functions per [“Checking brakes & motor cutoff switches” on page 35](#), but note that brakes can rub a little the first few times you ride. This is okay and normal; any squeak or noise should go away with use.
- Check everything on the “Before every ride” list below.

BEFORE EVERY RIDE

Before every, follow the safety checklist in the table below. On very long rides, check every ride or every 25–45 miles (40–72 km). If you find anything amiss with your trike, don't ride it until you're sure it's fixed. Consult a local, professional, reputable bike mechanic or explore our Help Center at radpowerbikes.com/help if you have any questions.

Fasteners

- Ensure that the folding mechanism on the stem riser is fully locked.
- Ensure all fasteners are correctly tightened according to [“Tools and torque specifications” on page 11](#).
- Check that the quick-release lever on the seatpost is tight and properly secured.
- Check that the fasteners on any accessories you've added are properly tightened according to the manufacturer's instructions.

Brake system

- Check brake pads and ensure the brake pad material isn't thinner than the backing plate it attaches to.
- Ensure brake pads are correctly positioned in relation to the brake rotors.
- Ensure brake cables are lubricated, correctly adjusted, and show no obvious wear.
- Ensure the brake lever is properly positioned and tightly secured to the handlebar.
- Ensure the brake lever tension is appropriate.
- Check that the taillight brightens when you squeeze the brake lever.
- Use the techniques in [“Checking brakes & motor cutoff switches” on page 35](#) to test the brake lever, brakes, and motor cutoff switch.

Drivetrain: cranks, pedals, chain, chain tensioner

- Ensure pedals are securely tightened to the cranks, that cranks are not bent, and that cranks are securely tightened to the bottom bracket. See [“Tools and torque specifications” on page 11](#).
- Ensure the chain is clean, lubricated, and runs smoothly. Take extra care with chain maintenance if the trike is used in wet, salty, dusty, or otherwise damaging conditions.
- Check that the chain tensioner is aligned and functioning properly.

Motor drive assembly

- Ensure the hub motor is spinning smoothly and is in good working order.
- Ensure the power cable running to the hub motor is secured and undamaged.
- Check the axle nuts to ensure they are correctly tightened (see [“Tools and torque specifications” on page 11](#)).
- Ensure the torque washers, torque arm, and torque arm bolt are in place and secured.

Steering

- Ensure the handlebar and stem are correctly aligned, adjusted, and tightened for proper steering.
- Perform the tests in [“Handlebar twist and push tests” on page 37](#) to ensure the handlebar and stem are secure.
- Ensure the handlebar grips are secure and undamaged.

Bearings

- Check that headset, wheel, pedal, and bottom-bracket bearings are lubricated, run freely, and display no excess movement, grinding, or rattling.

Wheels and tires

- Ensure tires are holding air and inflated to within the PSI limits displayed on the tire sidewalls.
- Ensure tires have good tread, have no bulges or excessive wear, no cracks, and are free from any other damage or foreign objects.
- Ensure rims run true and have no obvious wobbles, dents, or kinks. See [“Tire and wheel care” on page 36](#).
- Check each wheel spoke. If any are loose or broken, seek help from a professional, reputable mechanic.
- Check the security of all wheel axle nuts to ensure they are correctly tightened (see [“Tools and torque specifications” on page 11](#)). Axle nuts can loosen with normal use.



WARNING: An improperly secured front or rear wheel can cause loss of control, accidents, serious injury, or death. Check that the wheels are properly secured during assembly and before each ride.

Frame, fork, and seat

- Check that the frame and fork are not bent or broken.
- Check that the seat is adjusted properly, that the seatpost quick-release lever is securely tightened, and that the seat does not move when the lever is closed. Ensure that the seatpost minimum insertion marking is fully inserted into the frame.

Battery

- Ensure the battery is charged.
- Ensure there is no damage to the battery.
- Ensure the battery gauge on the Rad UI Remote and the charge status indicator on the battery read similarly.

Cables

- Look over electrical cable connectors to make sure they are fully seated and free from debris or moisture.
- Check cables and cable housing for obvious signs of damage.
- Ensure cables are secured away from moving parts.
- Ensure headlight, taillight, and brake light are functioning, adjusted properly, and unobstructed.

Accessories & safety gear

- Ensure all reflectors are properly fitted and not obscured.
- Ensure all accessories and components installed on the trike are properly secured and functioning according to their manufacturer’s specifications.
- Check all safety gear, clothing, cargo, and accessories for loose or potentially loose elements and secure them.
- Ensure rider wears a helmet and other required riding safety gear, and inspect these items for signs of damage.
- If your trike has fenders: Ensure they are centered over the wheels, adjusted properly, properly secured (see [“Tools and torque specifications” on page 11](#)), and have no cracks or holes.



WARNING: Riding your trike when any component’s useful life is surpassed can cause that component to fail, resulting in loss of control, serious injury, or death. Pay attention to signs of wear such as cracks, scratches, component color change, and operational changes that could indicate a component needs replacing. Before each ride, check your trike using the [“Safety checklists” on the previous page](#). Perform regular maintenance according to [“Recommended service intervals” on page 34](#). If you’re not sure you have the experience, skills, and tools to perform safety checks and regular maintenance, consult a professional, reputable bike mechanic for help.

AFTER EVERY RIDE

- Store your trike and battery in a dry location and follow the advice in [“Parking, storage, and transport” on page 27](#).
- Guard against damage from the elements. See [“Guard against rust, corrosion, and water damage” on page 38](#).
- Charge your battery in a dry, indoor location according to the directions in [“Battery information” on page 15](#).

Maintenance

Follow these maintenance guidelines to ensure your RadTrike stays safe and fun to ride.

Check and service your trike regularly

On any bike or trike, certain parts need to be replaced periodically due to wear, and sometimes parts become damaged for various reasons. Check your trike before each ride by following the directions in [“Safety checklists” on page 31](#). Have your trike regularly serviced by a professional, reputable bike mechanic. See [“Recommended service intervals” below](#) for more information.

Components of any electrical bike or trike are subject to higher wear compared to the components of bikes without power assistance. This is because ebikes can travel at higher average speeds than regular bicycles and generally weigh more. Higher wear is not a defect in the product and is not subject to warranty. Typical components affected are the tires, brake pads and rotors, forks, spokes, wheels, and the battery.

If you need to replace a part on your trike, visit radpowerbikes.com. If you want something that isn't listed there, contact Rad Power Bikes Product Support. Be extremely careful about using parts or accessories that Rad Power Bikes has not tested for safety and compatibility with your specific product.



WARNING: Using aftermarket accessories or components (trailers, stands, vehicle racks, etc.) that have not been tested by Rad Power Bikes for safety and compatibility with your specific trike may void your warranty, create an unsafe riding condition, result in trike/property damage, or cause serious injury or death. If you use replacement parts or accessories not tested and recommended by Rad Power Bikes, you do so at your own risk.

Recommended service intervals

Regular maintenance of any bike or trike is key to ensuring the best possible performance and reducing wear and tear on systems. Ideal service intervals vary depending on use conditions. We generally recommend inspections, service, and necessary replacements be performed at the time and distance intervals described below, but you should have your trike serviced more frequently if you ride aggressively, with heavy payloads, or in harsh conditions. Have your trike inspected immediately if you notice problems or your trike has been involved in a fall or other accident.



WARNING: Have your trike inspected by a professional, reputable bike mechanic after any fall, crash, or accident, as these can cause damage (visible or internal/not readily apparent), make your trike unsafe, and lead to serious injury or death. Be particularly cautious about using a battery that has experienced a significant impact from a fall or crash; a damaged battery may not show external signs of damage. Using a damaged battery or charger can create additional trike damage or a fire hazard. For more information, see [“Battery information” on page 15](#).

AFTER BREAK-IN PERIOD OF 50–100 MILES (80–160 KM)

- Inspect**
- Check all cables and the chain for stretch.
 - Check spoke tension and the trueness of the wheels.
 - Check all bolted connections for loosening and ensure they are tightened to recommended torque values (see [“Tools and torque specifications” on page 11](#)).
- Service**
- Have a professional, reputable bike mechanic perform a thorough tune-up.



WARNING: Certain components can stretch or loosen during any bike or trike's break-in period, which can lead to component failure and potential injury or death. Be sure to have a professional, reputable bike mechanic perform a thorough tune-up after this break-in period or sooner if you notice any problems or if you ride aggressively, with heavy payloads, or in harsh conditions.

WEEKLY, 100–200 MILES (160–320 KM)

- Inspect**
 - Check hardware for proper torque—see [“Tools and torque specifications” on page 11](#).
 - Check drivetrain for proper alignment and function (including chain, freewheel, chainring, and chain tensioner).
 - Check wheel trueness and spoke tension, and check for quiet wheel operation (without spoke noise).
 - Check frame for any damage.
- Service**
 - Clean frame by wiping frame down with damp cloth.
 - If needed, adjust the brake tension.
 - Clean and grease the chain. More information is available online at radpowerbikes.com/help.
- Replace**
 - Replace any components confirmed to be broken or damaged beyond repair by Rad Power Bikes Product Support or a professional, reputable bike mechanic.

MONTHLY, 250–750 MILES (400–1200 KM)

- Inspect**
 - Check brake pad wear, alignment, and the brake lever tension.
 - Check chain stretch.
 - Check chain alignment and drivetrain functioning.
 - Check brake cables for corrosion and fraying.
 - Check wheel trueness and spoke tension, and check for quiet wheel operation (without spoke noise).
- Service**
 - Clean and lubricate drivetrain.
 - Check crankset and pedal torque.
 - Clean brake cables.
 - Tension spokes and true wheels if any loose spokes are found.
- Replace**
 - Replace brake cables if necessary.
 - Replace brake pads if necessary (typically when the pad material is thinner than the backing plate).

EVERY 6 MONTHS, 750–1250 MILES (1200–2000 KM)

- Inspect**
 - Inspect drivetrain (chain, chainring, freewheel, and chain tensioner).
 - Inspect all cables and housings.
- Service**
 - Standard tune-up by professional, reputable bike mechanic.
 - Grease bottom bracket.
- Replace**
 - Replace brake pads.
 - Replace tires if necessary.
 - Replace cables and housings if necessary.

Checking brakes & motor cutoff switches

All vehicles, including your RadTrike, need reliable brakes. Test your brake levers, brakes, and motor cutoff switches for proper functioning before every ride. If anything seems wrong, take your trike to a local, professional, reputable bike mechanic, refer to our Help Center (radpowerbikes.com/help), or contact Rad Power Bikes Product Support.



WARNING: Touching the brake rotor, which has sharp edges and can get very hot while you're riding, can cause serious injury, slicing damage, or burns. The brake rotor heats up from normal friction when the brake pads press against the brake rotor to slow or stop the trike. Touching the brake rotor with bare skin can also transfer natural oils to the rotor, and oils or other lubricants can decrease braking performance. **Do not touch the brake rotor, especially when it's in motion or after you've been riding your trike.** Touch the brake rotor only for necessary maintenance when it is cool, not moving, and while you are wearing gloves or using other appropriate protective equipment.



1. Test the brake lever.

- a. Fully squeeze the brake lever on your handlebar, and ensure it does not touch the handlebar grip.
- b. Ensure the brake lever is properly lubricated. If it is, it will be reasonably easy to squeeze without feeling as though there's grit in the mechanism. When you release the lever, it should immediately go back to its original position.
- c. Make sure the lever is properly oriented and firmly secured to the handlebar.

2. Test the front brake.

Squeeze the brake lever to lock the front brake, and then try to push the trike forward using the handlebar. The front wheel should not spin.



WARNING: The coaster brake (foot brake) does not contain a motor cutoff switch. Do not attempt to operate the throttle while the coaster brake is engaged. Operating the throttle or pedal assistance while the coaster brake or parking brake is engaged may lead to damaged components or accidents..

Tire and wheel care

The tires and inner tubes that came with your trike are designed for durability and safety for regular cycling activities. Wheels and tires need to be checked before each use to make sure they're in good condition. Always replace tires and inner tubes that have punctures, cuts, bulges, damage, or excessive wear before you ride.

TIRE INFLATION

Inflate tubes and tires to within the PSI (pounds per square inch) range stamped onto the tire sidewall. For additional information about tire pressure, please consult our Help Center at radpowerbikes.com/help.



NOTICE: Be sure not to confuse the PSI value on your tire sidewall with the "TPI" (threads per inch) value, which may also be listed there.



WARNING: Underinflating your tires can result in loss of control. Overinflating can make tires burst. Either scenario can lead to serious injury or death. Always maintain the correct air pressure of your tires, which is listed on the tire's sidewall, and use a regulated air source with pressure gauge so that you can measure pressure accurately.

WHEEL "TRUENESS"

Your wheels should always spin straight ("true") and must be repaired or replaced if they wobble side to side or up and down when spinning. To test them, do this:

1. Spin the wheel.
2. Brace a dull pencil against the frame or fork, with the tip just touching the rim.

If the gap between the spinning rim and pencil changes more than 5 mm, your wheels may need truing. If your wheels become untrue or if spokes loosen, which can happen with normal use, we recommend that you have a professional, reputable bike mechanic perform wheel tuning and truing operations. Do not attempt to true wheels or tighten spokes unless you have the highly specialized skills and tools to do so.

TIRE REPLACEMENT

Even tires equipped with built-in flat-preventative tire liners, like those that come with your RadTrike, can and do get flats from punctures, pinches, impacts, and other causes. If you get a flat tire or see evidence of tire wear, you must

replace your tire and/or tubes before operating the trike again. Otherwise, you risk trike damage, serious injury, or death.



CAUTION: Removing a tube from your wheel rim before the air has been released from it can cause the tube to burst, potentially causing serious injury. Always release air pressure before removing your tube.



WARNING: Aftermarket tires or inner tubes not provided by Rad Power Bikes may not be compatible with your wheels or the performance requirements of your trike. Such tires can fail or create unsafe riding conditions, causing serious injury or death. Always use replacement tires and tubes that are sized to be compatible with your trike frame. For safety, and if required by law, ensure replacement tires have sufficient reflective sidewall striping.

After replacing a tire or removing the wheel for any other reason, be sure to tighten your axles according to the values listed in [“Tools and torque specifications” on page 11](#). For more information on tire or tube replacement, visit radpowerbikes.com/help or contact Rad Power Bikes Product Support.

Handlebar twist and push tests



WARNING: An improperly secured wheel and/or handlebar stem can cause loss of control, accidents, serious injury, or death. Check that the front wheel and handlebar stem are properly secured during assembly and before each ride.

HANDLEBAR TWIST TEST

The following twist test will help you verify that your stem riser clamp bolts and stem clamp bolts are tight enough.

1. **Get the trike ready for testing.** Turn off the trike, remove the battery, and press and hold the power button to discharge remaining power.
2. **Check that the folding mechanism on the stem riser is properly secured.** Press upward on the release button on the stem riser’s locking lever until you can push the lever down, as in the “Release the latch on the stem riser” illustration. Then press the latch back up. **Make sure you hear a “click” and that the release button slides downward into position.**
3. **Brace the front wheel.** Stand at the front of the trike, facing the handlebar, and brace the front wheel between your feet and lower legs.
4. **Try to twist the handlebar.** Hold both handlebar grips and push forward with one hand while pulling back with the other. Push and pull at the same time with about 20 lb of force with each hand.
5. **Ensure the handlebar and wheel stay properly aligned.** The handlebar and handlebar stem should be tightly secured, and the handlebar should be perpendicular to the front wheel.
6. **Repeat the twist test pulling/pushing with the opposite hands,** using about 20 lb of force pushing with one hand and 20 lb of force pulling with the other hand.
7. **Check for any movement or changes in alignment of the stem and handlebar relative to the front wheel.** If there was no alignment change, skip the next step, reinstall your battery, and test your trike fully before riding. If you did *not* notice change in alignment, proceed to the next step. If you *did* detect movement, you’ll need to loosen and retighten the stem clamp bolts and stem riser clamp bolts according to the directions in the assembly instructions. Be sure to tighten your bolts according to the values listed in [“Tools and torque specifications” on page 11](#).

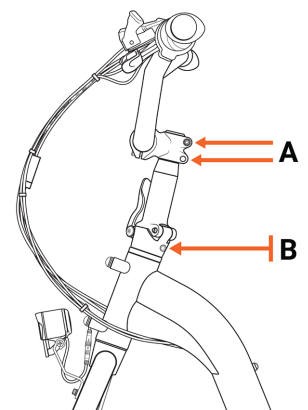

Stem clamp bolts (A)
and stem riser clamp
bolt (B)

HANDLEBAR PUSH TEST

This test will involve applying force directly to your handlebar to see whether it could pivot unexpectedly during operation. The illustration at right shows the type of motion this procedure tests for.

1. **Get the trike ready for testing.** Turn off the trike, remove the battery, and press and hold the power button to discharge remaining power.
2. **Make sure your handlebar is centered on the stem.** Your handlebar has the widest diameter at its center. If it isn't centered, it could come loose. Center your handlebar, loosening and retightening the stem faceplate bolts as necessary.
3. **Brace your front wheel.** Roll your trike up to a wall so that your front wheel is touching the wall and is perpendicular to the wall. Stand over your frame as though you're about to ride it, and then sit down. If necessary, lower the seat so that you can sit on it while your feet are on the ground. Place both hands on the handlebar and squeeze the brake levers.
4. **Push your handlebar.** Begin by pushing with medium force, watching for any pivot in the handlebar. Increase the force until you are pushing as hard as you can, ideally with 100 lb (45 kg) of total force.
5. **If your handlebar did not pivot, it's tight enough.** If your handlebar did pivot, you will need to loosen and re-tighten the stem faceplate bolts as described in the assembly instructions. Be sure to torque the bolts according to ["Tools and torque specifications" on page 11.](#)

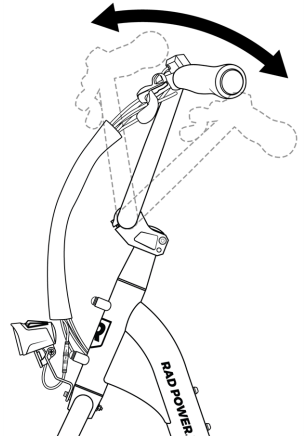

WARNING: Improperly securing your handlebar, stem, or stem riser can result in loss of control of your trike, serious injury, or death. If you are not sure you have the experience, skills, and tools to correctly perform all steps to secure and verify the security of the handlebar, front wheel, and handlebar stem you **MUST** consult a professional, reputable bike mechanic to check your work and/or secure those components to the trike properly.

Guard against rust, corrosion, and water damage



WARNING: Damage to your trike's electrical system caused in any manner, including water intrusion, can lead to battery failure, electrical system malfunction, or electrical fire and consequent property damage, injury, or death. Follow all instructions to minimize chance of water damage. If you have any questions, contact Rad Power Bikes Product Support.

Like any vehicle used outdoors, your RadTrike needs care to ensure it isn't damaged by the elements. Follow these steps for a long, healthy life for your trike:

- Store under shelter and in an upright position; avoid leaving the trike in the rain or exposed to corrosive substances such as water, salt, or de-icing substances. If exposed to rain, dry your trike afterward, and apply an anti-rust treatment to the chain and other unpainted steel surfaces.
- To clean your trike, turn it and the battery off and wipe the frame with a clean, damp cloth. If needed, apply a mild, non-corrosive detergent mixture to the damp cloth and wipe the frame. Dry by wiping with a clean, dry cloth. **Never use high-pressure water on your trike.** Wipe down your trike frequently and wipe or spray all unpainted mechanical parts with anti-rust treatment.
- If painted metal parts become scratched or chipped, use touch up paint or nail polish to prevent rust.
- **Never immerse or submerge the trike or any components in water or liquid, which can damage the electrical system.**
- Avoid riding on the beach, in coastal areas with high-salinity fog, or on surfaces treated with salt or de-icing compounds. Doing so exposes your trike to salt or other substances that are very corrosive. Corrosion of electrical components can lead to permanent damage that can cause battery failure, electrical system failure, or electrical fire. Damage from corrosion is not covered under warranty.

Troubleshooting

Problem	Most common solutions
Trike doesn't work:	
Insufficient battery power	Charge the battery
Battery not fully seated in tray	Install battery correctly
Faulty connections	Clean and reconnect connectors
Improper turn-on sequence	Turn on trike with proper sequence
Brakes are squeezed	Disengage brakes
Discharge fuse issue	Replace 40A discharge fuse
Throttle stops working:	
Communications error with or without error 30 displayed	Consult our Help Center at radpowerbikes.com/help .
Reduced range:	
Low tire pressure	Check for tire punctures or other damage. Inflate tires to PSI stamped on sidewall.
Low battery	Charge battery
Driving with too many hills, headwind, braking, or excessive load	Assist with pedals or adjust route
Battery discharged for long period without regular charges	Recharge the battery. If range decline persists, consult our Help Center at radpowerbikes.com/help .
Brakes rubbing	Adjust the brakes
Faulty, damaged, or aged battery	Contact Rad Power Bikes Product Support to replace battery. Disconnect and store damaged battery in a safe location and recycle or dispose of as soon as possible according to local rules.
The battery won't charge:	
Charger not well connected	Adjust the charger connection
Charger damaged	Replace the charger
Battery damaged	Immediately stop use. Disconnect and store battery in a safe location and recycle or dispose of as soon as possible according to local rules. Contact Rad Power Bikes Product Support to replace battery.
Wiring damaged	Replace wiring
Charge fuse issue	Replace the 10A charge fuse
Wheel or motor makes strange noises:	
Loose motor cable connection	Reconnect cable
Damaged wheel spokes or rim	Repair or replace damaged component(s)
Damaged motor	Replace motor

Error detection

Your RadTrike is equipped with an error detection system integrated into the display and motor controller. In the case of an electronic control system fault, an error code should appear on the Rad UI Remote. If your trike has an error code displayed at any time, stop riding and look up the error code information at radpowerbikes.com/help. Contact Rad Power Bikes Product Support if you have questions.

The Rad UI Remote displays signals an error code with a large “E” and lighted bars (circled in green in the “Rad UI Remote” illustration). In the illustration, the lower two bars represent the first digit, “2,” and the top three bars represent the second digit, “3,” to form the error code “23.”

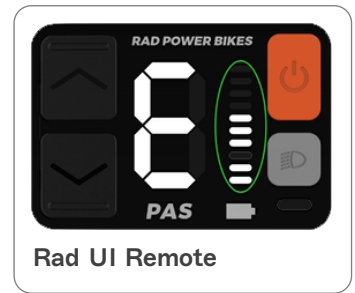

The following error codes are the most common.

Error	Definition
21	Abnormal current
22	Throttle fault
23	Motor phase fault
24	Motor hall fault
25	Brake switch fault or the hand brake applied while turning on
30	Communication fault
31	Power button hold fault

If an error code displays, make note of the number or take a picture. Try turning the trike off and then back on. If the error persists, turn off the trike and then stop touching it to ensure you aren't causing the error by accidentally pressing a button, etc. Go to our Help Center (radpowerbikes.com/help) to look up information on the error code or contact Rad Power Bikes Product Support.

Ride as safely as possible

Operating any bike or trike is an exciting, delightful, and practical way to get around, but like any sport, it involves risk of injury and death. By choosing to ride any bike or trike, you assume responsibility for those risks.



WARNING: Incorrect assembly, maintenance, or use of your trike can cause component or performance failure, loss of control, serious injury, or death. Even if you're an experienced bike rider, **you must read and understand the entire manual and any documentation provided for subcomponents or accessories before riding.** If you are not sure you have the experience, skills, and/or tools to correctly perform all assembly steps in the manual and the assembly video at rad-go.com/trike, have a local, professional, reputable bike mechanic assemble your trike.

Age and ability requirements

You must be age 16 or older to operate the RadTrike. You must also have the physical ability, reaction time, and mental capability to understand and obey all local laws governing ebike usage and to manage traffic, variable road conditions, and sudden situations. If you have an impairment or disability (e.g., visual impairment, hearing impairment, physical impairment, cognitive or language impairment, seizure disorder) or any other limitation that could affect your ability to safely operate a vehicle, consult your physician before operating any bike, trike, or similar vehicle.



WARNING: This trike is not to be operated by anyone under the age of 16. Children under the age of 16 may lack the necessary judgment and skill to safely operate the trike, potentially resulting in damage to the trike, damage to other property, serious injury, and/or death. Please also check your local laws, which may require a higher age. It is your responsibility to know and obey local regulations regarding rider age and other qualifications.



MINIMUM
OPERATOR AGE



DANGER: Riding any vehicle under the influence of alcohol, drugs, or any substance or condition that could impair your motor function, judgment, reaction time, or ability to safely operate a vehicle puts you at VERY HIGH RISK of serious injury or death. Operate your trike or other vehicles only when you're sober and otherwise physically and mentally prepared to ride safely.

Know and obey all relevant local laws

It is your responsibility to research and understand relevant laws where you ride your RadTrike, which meets the criteria for a Class 2 ebike in the United States. Local laws may cover required helmets and safety gear, required lights and reflectors, required hand signals, where you can legally ride an trike (bikes and ebikes may have different restrictions), how fast you can go, what (if any) cargo or passengers you can carry, rider age, and more. Before using public transportation—buses, trains, etc.—to transport your trike, check with the relevant transportation authority for any rules governing weight limits, tire widths, lithium-ion batteries, or any other rules that might pertain to your RadTrike. Make sure you know ahead of time whether and how high you will need to lift your trike, and make sure you can do that safely.

When you ride on the road, assume you must, at minimum, follow all of the rules that cars must follow. For additional information regarding traffic and vehicle laws, contact the road traffic authority in your area.

Ride appropriately for conditions

Always travel at speeds appropriate for local terrain and conditions as well as your experience level. **When in doubt, slow down.**

Ride with your headlight on, which will make you more visible in any conditions. The headlight will turn on when the trike is powered on. We recommend you keep it on whenever you ride.

Concentrate on the path ahead. Avoid potholes, gravel, ice, wet or oily roads, wet leaves, curbs, train tracks, speed bumps, drain gates, thorns, broken glass, and other obstacles, hazards, and puncture-flat risks.



WARNING: Crossing train tracks or similar grooved or raised surfaces at a diagonal can make the surface “grab” or deflect your wheel, causing your trike to suddenly get stuck or crash, leading to serious injury or death. Always cross such hazards at a perpendicular angle or, when in doubt, dismount and walk your trike across.

PATH RIDING

Be a good citizen of shared-use paths and facilities. Keep your speed reasonable and below path speed limits, pass carefully and kindly. Use your voice and/or bell to signal your presence to others, especially when passing. Keep in mind that your trike is heavy, can go at high speeds, and can hurt others if not operated with care.

ROAD RIDING

When riding on streets, obey the same road laws as all other road vehicles as well as local rules governing bike or ebike usage. Sharing the road with other vehicles presents many hazards. Always take these precautions:

- Expect the unexpected such as opening car doors or cars backing out of driveways.
- Be extra careful at intersections and when preparing to pass other vehicles or other cyclists.
- Ride predictably, in a straight line, and with the flow of traffic. **Never ride against traffic.**
- Use correct hand signals to indicate turning, and do so well in advance of turning.
- Ride defensively. To other road users you may be hard to see.
- Increase your visibility by following the tips in [“Low-visibility conditions” below](#).

OFF-ROAD RIDING

Riding off road requires close attention and specific skills, and it presents variable conditions and hazards. Don't ride off road unless you have the appropriate skills. If you choose to ride off road, wear appropriate safety gear and do not ride alone in remote areas.

LOW-VISIBILITY CONDITIONS



WARNING: Riding at night or in other low-visibility conditions (dawn, dusk, fog, rain, mist, snow, etc.) makes it harder to see and avoid hazards and makes it harder for others to see and avoid you, which increases risk of accidents, serious injury, or death. Wet, slippery surfaces will compound your risk of injury or death. Avoid these conditions whenever possible. If you must ride in these conditions, following the guidelines below can reduce risk.

- Wear reflective and brightly colored clothing.
- Slow down.
- Use familiar routes with street lighting if possible.
- Ensure tire wall, pedal, and other reflectors are installed and unobstructed.
- Ensure headlight and taillight/brake light are functioning correctly and unobstructed. Use them.

WET CONDITIONS

Your RadTrike is not meant for use in puddles, heavy rain, or streams. Never immerse or submerge this product in water or liquid as the electrical system may be damaged.



WARNING: Riding in wet conditions means slippery hands, feet, and riding surfaces, which greatly increases your risk of accidents, serious injury, or death. Low-visibility conditions (night, dusk, dawn, fog, mist, rain, snow, etc.) will compound your risk of injury or death. Avoid riding in such conditions. If you choose to ride in wet conditions, you do so at your own risk. Follow the recommendations below to reduce that risk.

- Decrease riding speed to help you control the trike in slippery conditions.
- Brake earlier since it will take longer to slow down than in dry conditions.
- Take care to be more visible to others on the road, following the tips in [“Low-visibility conditions” above](#).
- Remember that road hazards are more difficult to see when wet, so proceed with extra caution.

EXTREME RIDING

There are no appropriate conditions for extreme riding. Although many articles, advertisements, and catalogs depict extreme riding, Rad Power Bikes strongly advises against such inappropriate and dangerous use of its products.



DANGER: Extreme riding puts you at **VERY HIGH RISK** of serious injury or death. Extreme riding includes but is not limited to jumps, stunts, or any riding that exceeds your capabilities or the strength and integrity limitations of certain trike components and/or otherwise leads to dangerous situations. Never engage in extreme riding or any type of riding that exceeds your capabilities.

Wear a helmet and appropriate safety gear

We strongly advise that you wear a properly fitting, certified bicycle safety helmet while riding your trike, which may be required by law in your area.

Wear appropriate safety gear including closed-toe shoes. If you are wearing loose pants, secure the bottom using appropriate leg clips or bands to prevent the fabric from flapping and getting caught in the chain or other moving parts. Never use items such as headphones or hoods that can compromise your hearing or field of vision. A local, professional, reputable bike shop can help advise you on what gear is best for the weather and other riding conditions in your area.

Maximize your visibility with bright colors and reflective outerwear or vests. Never compromise your ability to be seen or heard by removing your trike's reflectors, blocking or removing the headlight or taillight, or removing the bell.



DANGER: Riding any bike, trike, or similar vehicle without a helmet puts you at **VERY HIGH RISK** of serious head injury or death. Always wear a properly fitted helmet that covers the forehead. Many locations require specific safety devices. It is your responsibility to familiarize yourself and comply with the laws, rules, and regulations where you ride.



WEAR A HELMET

Limited warranty and other terms

Your trike's warranty and other binding legal terms (e.g., terms of purchase, etc.) are subject to change at any time. To view your terms of purchase, go to radpowerbikes.com/terms. To view the current warranty, please go to radpowerbikes.com/warranty.

RAD POWER BIKES LIMITED 1 YEAR WARRANTY TERMS

All Rad Power Bikes ("RPB") ebikes (the "ebike"), and their individual Covered Components (as defined herein), are protected against all manufacturing defects in material or workmanship for one (1) year after the date of receipt of this ebike by the customer (the "Warranty Period"). This Limited Warranty is only applicable to United States ebike purchases (purchases in Canada and Europe shall be subject to their respective warranty terms) and in accordance with the following terms:

- Only the original owner of an ebike purchased from RPB's online or physical storefront is covered by this Limited Warranty. The Warranty Period begins upon your receipt of the ebike and shall end immediately upon the earlier of the end of the Warranty Period or any sale or transfer of the ebike to another person, and under no circumstances shall the Limited Warranty apply to any subsequent owner or other transferee of the ebike.
- The Limited Warranty is expressly limited to the replacement of any of the following components that come standard on your ebike model (not all parts listed come standard with all models), if those components are found to be defective: lithium ion battery (the "Battery"), frame, forks, stem, handlebar, headset, seat post, saddle, brakes, lights, bottom bracket, crank set, pedals, rims, wheel hub, freewheel, cassette, derailleur, shifter, chain tensioner, motor, throttle, controller, wiring harness, LCD display, LED display, UI display, remotes, kickstand, reflectors and hardware (each a "Covered Component").
- The Covered Components are warranted to be free of defects in materials and/or workmanship during the Warranty Period.

THIS LIMITED WARRANTY DOES NOT COVER:

- Normal wear and tear of any Covered Component.
- Consumables or normal wear and tear parts (including without limitation tires, tubes, brake pads, cables and housing, grips, chain and spokes).
- Any damage or defects to Covered Components resulting from failure to follow instructions in the ebike owner's manual, acts of God, accident, misuse, neglect, abuse, commercial use, alterations, modification, improper assembly, installation of parts or accessories not originally intended or compatible with the ebike as sold, operator error, water damage, extreme riding, stunt riding, or improper follow-up maintenance.
- For the avoidance of doubt, RPB will not be liable and/or responsible for any damage, failure or loss caused by any unauthorized service or use of unauthorized parts.
- The Battery is not warranted from damage resulting from power surges, use of an improper charger, improper maintenance or other such misuse, normal wear or water damage.
- Any products sold by RPB that is not an ebike.

DETERMINING WHETHER DAMAGE OR DEFECT TO AN E-BIKE OR COVERED COMPONENT IS PROTECTED BY THIS LIMITED WARRANTY SHALL BE IN THE SOLE DISCRETION OF RPB.

SHIPPING DAMAGE

Damage to a Covered Component during shipping is not covered by this Limited Warranty, but RPB will replace such damaged Covered Components if you:

- Notify RPB of a Covered Component damaged in the shipping process within thirty (30) days of your receipt of the ebike;
- Provide RPB with a dated picture of the damaged Covered Component;
- Return all original packaging and paperwork included with the ebike; and
- Note any immediately recognizable damage on the shipper's Bill of Lading prior to signing off on the shipment.

Shipping damage claims are very time sensitive and it is your responsibility to immediately inspect the ebike for damage upon receipt.

If you choose to set up your own independent shipping method, such as use of a freight forwarder or other similar service, RPB will not replace any Covered Components damaged during such shipping method.

CREDIT CARD CHARGEBACKS

If any E-Bike purchase becomes subject to a credit card chargeback in any amount, and you are still in possession of the ebike, then this Limited Warranty shall be invalidated until the credit card chargeback has been resolved.

Claims process

RPB WILL NOT REPLACE ANY COVERED COMPONENT UNDER THIS LIMITED WARRANTY WITHOUT FIRST SEEING PHOTOS OR VIDEO OF THE DAMAGED COVERED COMPONENT.

In order to exercise your right to receive a replacement for a Covered Component under this Limited Warranty, you must:

- Contact the RPB Product Support team by email at support@radpowerbikes.com or by phone at 1-800-939-0310. The Product Support team will initially work with you on the problem with your ebike to identify potential simple fixes.
- In the event that the Product Support team determines that a Covered Component must be replaced, they will provide you with a set of instructions for returning the defective Covered Component and receiving the replacement.
- After you receive the replacement Covered Component, the Product Support team will also provide assistance in determining how to replace or install the new Covered Component into your ebike.
- You will be responsible for shipping costs associated with returning a Covered Component, unless RPB agrees in writing to pay for such shipping costs. Replacement Covered Components under this Limited Warranty shall only be shipped to the address of the original purchaser.

THE REMEDIES DESCRIBED ABOVE ARE YOUR SOLE AND EXCLUSIVE REMEDIES AND RPB'S ENTIRE LIABILITY FOR ANY BREACH OF THIS LIMITED WARRANTY. RPB'S LIABILITY SHALL UNDER NO CIRCUMSTANCES EXCEED THE ACTUAL AMOUNT PAID BY YOU FOR THE EBIKE, NOR SHALL RPB UNDER ANY CIRCUMSTANCES BE LIABLE FOR ANY CONSEQUENTIAL, INCIDENTAL, SPECIAL OR PUNITIVE DAMAGES OR LOSSES, WHETHER DIRECT OR INDIRECT.

SOME STATES DO NOT ALLOW THE EXCLUSION OR LIMITATION OF INCIDENTAL OR CONSEQUENTIAL DAMAGES, SO THE ABOVE LIMITATION OR EXCLUSION MAY NOT APPLY TO YOU.

THIS LIMITED WARRANTY GIVES YOU SPECIFIC LEGAL RIGHTS AND YOU MAY ALSO HAVE OTHER RIGHTS, WHICH VARY FROM STATE TO STATE.

TO THE EXTENT PERMISSIBLE UNDER APPLICABLE LAW, RPB DISCLAIMS ALL IMPLIED WARRANTIES, INCLUDING WITHOUT LIMITATION THE WARRANTIES OF MERCHANTABILITY AND FITNESS FOR A PARTICULAR PURPOSE FOR THE DURATION OF THE EXPRESS LIMITED WARRANTY.

SOME STATES DO NOT ALLOW LIMITATIONS ON HOW LONG AN IMPLIED WARRANTY LASTS, SO THE ABOVE LIMITATION MAY NOT APPLY TO YOU.

ASSEMBLY VIDEO AND ONLINE RESOURCES

Please watch the official RadTrike Assembly Video, download the latest version of this manual, and explore other resources at rad-go.com/trike or with the QR code at right.



rad-go.com/trike

Thanks for riding Rad!