



R I D E  
R A D

2018

R A D W A G O N

# RAD POWER BIKES

O W N E R ' S M A N U A L



## Welcome

Thank you for purchasing the RadWagon™ from Rad Power Bikes™. We take pride in bringing you a quality product that will offer years of enjoyment.

Thanks for riding RAD!

## Using This Manual

This manual contains details of the product, its equipment, and information on its operation and maintenance. Read it carefully and familiarize yourself with the RadWagon before using it to ensure safe use and prevent tragic accidents. Be sure to retain this manual as your convenient RadWagon information source.

This Manual contains many Warnings and Cautions concerning the safe operation and consequences if safe setup, operation and maintenance are not performed. All information in this manual should be carefully reviewed and if you have any questions you should contact Rad Power Bikes immediately. The notes, warnings and cautions contained within the manual and marked by this triangular Caution Symbol should also be given special care. Users should also pay special attention to information marked in this manual beginning with **NOTICE**.



Because it is impossible to anticipate every situation or condition which can occur while riding, this manual makes no representations about the safe use of bicycles under all conditions. There are risks associated with the use of any bicycle which cannot be predicted or avoided, and which are the sole responsibility of the rider. You should save this manual, along with any other documents that were included with your bicycle, for future reference, however all content in this manual is subject to change or withdrawal without notice. Visit [www.radpowerbikes.com](http://www.radpowerbikes.com) to download the latest version. Rad Power Bikes makes every effort to ensure accuracy of its documentation and assumes no responsibility of liability if any errors or inaccuracies appear within. Assembly and first adjustment of your Rad Power Bike requires special tools and skills and it is recommended that this should be done by a trained bicycle mechanic if possible.

**We are here to help! Please contact us at [support@radpowerbikes.com](mailto:support@radpowerbikes.com) or 1-800-939-0310 if you have questions.**

# Table of Contents

- Welcome ..... 2
- Using This Manual..... 2
- General Info ..... 4
- Assembly Instructions..... 6
- Battery Charging ..... 11
- Operation ..... 15
- Maintenance ..... 24
- Troubleshooting..... 27
- Warnings and Safety..... 29
- Link to Assembly Video and Online Resources ..... 34
- Limited Warranty ..... 34

## General Info

### Assembly and Fit

Correct assembly and fit are essential elements of ensuring your bicycling safety, performance and comfort. If you have the experience, skill and tools to complete these essential steps before your first ride, Rad Power Bikes recommends having a certified bicycle mechanic check your work.

**NOTICE:** If you do not have the experience, skill and tools to complete assembly and fit, Rad Power Bikes highly recommends having a certified bicycle mechanic complete these procedures as well as ensure any future adjustments or tuning.

**NOTICE:** A critical aspect of assembling your Rad Power Bike is securing the front wheel and checking the tightness of the rear wheel axle nuts. All Rad Power Bikes use a quick release front wheel mounting mechanism and the rear wheel is bolted on. Both wheels need to be properly secured before operating your bike.

### Mandatory Equipment and Use Locations

Before all rides, ensure you have all required and recommended safety equipment and are following all laws pertaining to using an electric bicycle in your region. For example, these laws may include the need for mandatory equipment, use of hand signals and where you can ride.

### Changing Components or Attaching Accessories

The use of non-original components or spare parts can jeopardize the safety of your RadWagon, invalidate your warranty and in some cases, cause your RadWagon to not conform with laws pertaining to your bike.



**The replacement of original components or installation of third party accessories or accessories from Rad Power Bikes not explicitly recommended for your bicycle model, is at your own risk.**

### Safety Check Before Each Ride

Always check the condition of your bicycle before you ride in addition to having regular maintenance performed. If you are unsure of how to conduct a complete check of the condition of your bicycle before every ride, you should consult a certified

bicycle mechanic for assistance. Here are some of the basic checks you need to perform to ensure safe operation and prolong the life of your bicycle:

### Electrical System

The electrical system on your Rad Power Bike offers various levels of power assistance and lighting for different operating conditions and user preferences. It is critical that you familiarize yourself with all aspects of your Rad Power Bikes electrical system and check to see that it is working correctly before every ride. The front and rear brake levers contain safety power cutoff switches which disable the hub motors assistance when applied, both levers should be checked for correct operation. The throttle should provide smooth acceleration when gradually applied. If the throttle, brake lever cutoff switches, pedal assistance or lighting is not functioning normally, intermittent, or not working, please discontinue using your Rad Power Bike immediately and contact Rad Power Bike technical support team for assistance.

### Brakes

Ensure brakes are working correctly, all braking system components are free from damage and properly secured. When you fully squeeze the brake levers, ensure neither the front or rear brake levers touch the handlebar. Take your bike to a certified bike mechanic to have the brakes repaired if you find a problem.

### Tires and Wheels

Your wheels should always spin straight and must be repaired or replaced if they wobble side to side or up and down when spinning. If your wheels become untrue or spokes loosen, do not attempt to true or tighten unless you have adequate knowledge, tools and experience. It is recommended that a certified bicycle mechanic performs all wheel tuning and truing operations on your Rad Power Bike. Ensure your tires and inner tubes are in good working condition without any visual damage and have the correct amount of air pressure. Always replace tires and inner tubes with punctures, cuts or damage before you ride. Tires without the correct amount of air pressure can reduce performance, increase tire and component wear and make riding your bicycle unsafe.

### Accessories, Straps and Hardware

Ensure all hardware is secured and all approved accessories are properly attached per the specific component manufacturers instructions. It is good practice to look over all hardware, straps and accessories before each ride and if you do discover something is wrong or find something you are not sure about, please have it checked a certified bicycle mechanic.

## Quick Release Levers

Quick release levers are located throughout the RadWagon for securing the seat post and the front wheel to the bicycle. These provide convenience to the user since they allow the front wheel to be removed, and the seat post to be adjusted without tools. Since quick release levers can be loosened during transportation, or accidentally between or during rides, it is important that you regularly check to ensure these components are properly secured.

## Suspension, Handlebar, Grips and Seat Adjustments

Check to ensure the handlebar, handlebar stem and seat post are properly fastened, aligned and fitted to the user. Ensure all the hardware securing the handlebars and seat are properly tightened including all quick release levers. Loose, worn or damaged handlebar grips should be replaced before you ride.

## Battery Pack Charged, Secured and Unplugged

Ensure the battery is fully charged and operating properly. The battery gauge on the LCD display and battery pack mounted charge status indicator should read similarly. The battery pack **MUST** be locked onto the frame battery mount, properly before use. Ensure the battery charger is unplugged from the battery pack and put away before you ride.

## Assembly Instructions

**NOTICE:** The following assembly steps are only a general guide to assist in the assembly of your Rad Power Bike and is not a complete or comprehensive manual of all aspects of assembly, maintenance and repair. We recommend you consult a certified bicycle mechanic to assist in the assembly, repair and maintenance of your bicycle.

**Step 1:** Remove bike from carton and carefully set out all contents of the box. Remove packaging material protecting the bicycle frame and components. Ensure the following pieces are included in the package. If there are any missing parts please contact Rad Power Bikes for help replacing missing pieces.

1. RadWagon
2. Front Wheel
3. Front wheel quick release
4. Front Fender

5. 2x running boards
6. Center Kickstand
7. Front fork anti-rotation spring and plastic cover
8. Running board end plugs
9. Pedals (Left and Right)
10. Headlight
11. Charger
12. Keys for battery pack
13. Assembly tools and manuals.
14. Complimentary Rad Power Bikes hat

**Step 2:** Assemble Kickstand onto bike using provided hardware as shown in the assembly video at [www.radpowerbikes.com](http://www.radpowerbikes.com).

**Step 3:** Install handlebar onto stem as shown in the assembly video for the RadWagon available at [www.radpowerbikes.com](http://www.radpowerbikes.com). Be sure to center the handlebar and ensure hardware is properly secured. Before fully securing the handlebars to the stem, adjust the stem angle using the Allen screws on the side of the stem. Once you have the desired handlebar height, rotate the handlebars in the stem until finding the ideal wrist angle and securely fasten all hardware.



**Step 4:** Assemble the front wheel onto the front fork as shown in the assembly video at [www.radpowerbikes.com](http://www.radpowerbikes.com). If there is damage to the front fork dropouts making it difficult to install the front wheel, please contact Rad Power Bike immediately for technical support as shipping damage could have occurred.



**Step 5:** Install the pedals. Use the pedal marked with an “L” on the left side and the right pedal marked with an “R” on the right side (side with drivetrain gears). The right-side pedal has a right-hand thread (removes counterclockwise, installs clockwise); the left side pedal has a left-hand thread (removes clockwise, installs counterclockwise). Be careful to not cross thread the pedals. Tighten securely as shown in the assembly video.



**Step 6:** Install the running boards using the provided hardware and using the steps shown in the assembly video. Running boards should be flat once secured, if they are sitting at an angle, loosen mounting hardware and hold them in a horizontal orientation while tightening.



**Step 7:** Inflate tires to desired PSI. Rad Power Bikes recommends 50-60 PSI for the front and rear tires on the RadWagon. Recommended tire pressure is indicated on the tire sidewall.



**Step 8:** Adjust the stem up and down to a comfortable height and secure all hardware in the stem assembly and seat post.



**Step 9:** Install front headlight and fender as well as the front fork anti-rotation spring and cover.

**Step 8:** Remove clear plastic strip from included rear taillight. Once removed you can depress the rubber button on top of the light once to turn on and twice to turn to flash mode. Press a third time to turn off. Once the bike is turned on, following the Operation section of this manual, you can turn on the headlight and LCD backlight by holding down the mode and up arrows on the display control pad on the left side of the handlebars.





**STEP 9:** The front headlight is equipped with a light sensor which will automatically dim the headlight partially when riding during day. The sensor is covered by a switch on the back of the headlight (side facing the rider). When the small opaque sensor is covered by the switch, the headlight, when turned on, will always be full brightness, daytime and nighttime. If the sensor is exposed, the headlight, when turned on, will be dimmed during the day automatically, and switch back to bright when it is dark out. This is designed to save power during daylight use, but the user can select either option based on preference.



**NOTICE:** Ensure all hardware is tightened properly and all safety checks in the following sections are performed before first use. Contact Rad Power Bikes if you have any questions regarding the assembly of your bike. If you are not able to ensure all the assembly steps in the assembly video are performed properly, or you are unable to view the assembly video please consult a certified local bicycle service provider for assistance in addition to contacting Rad Power Bikes for help.



**Do not extend any components including the stem or seat post beyond the minimum insertion markings on the seat post or maximum angle markings on the stem which are etched into the components. Ensure that all hardware is properly tightened and secured before moving on to next step otherwise serious injury or death could occur.**

### Recommended Torque Values

Hardware Location	Torque Required (Nm)
Handlebar Stem Clamp Bolts	10
Stem Faceplate Bolts	6
Stem Angle Adjust	18
Saddle	18-20
Seat	18-20
Rear Wheel	40-45
Bottom Bracket Parts	35-55
Pedals	35
Disk Mounting Bolts	6
Disk Caliper Mount	10
Crank Bolts	40
Rear Derailleur Cable Pinch	6

Front Derailleur Clamp	7
Seat Post Clamp	7

## Adjusting the Saddle Height

- 1) Open the quick release skewer by swinging open the lever outwards about 180 degrees.
- 2) You can now move the saddle up and down by sliding the seat post. Set the desired saddle height.
- 3) After tightening the finger nut on the seat post quick release properly, close the quick release lever by swinging the lever back 180 degrees until it looks like the image on the following page and the saddle cannot move up, down or to the left or right.

 **Before using the bike, check that the saddle post quick release skewer is closed and tightened properly. Check that it is correctly fitted before every ride and after every time the bike is left unsupervised, even for a short time. Otherwise, the saddle post may come loose and result in loss of control and serious injuries.**

For most users, the saddle height should be set by placing the ball of your foot on the pedal when the crank is at its lowest point. Your leg should almost be fully extended.



## Adjusting the Saddle Position and Angle

To change the angle and horizontal position of the saddle:

- 1) Undo the Allen head bolt underneath the saddle on the saddle clamp positioned immediately underneath the saddle, above the rear wheel.
- 2) You can now move the saddle backwards or forwards in the guide and adjust the angle of the saddle before retightening. A horizontal position is desirable for most riders. There are white limit markings on the saddle rail, which show the minimum and maximum horizontal movement allowed for this component, do not exceed these limits.

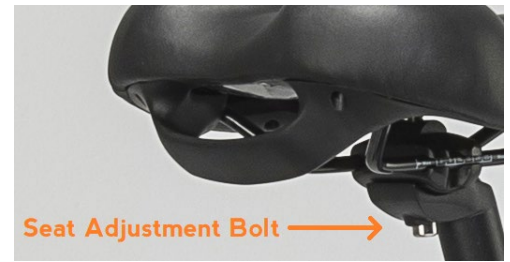

**NOTICE:** Ensure saddle post and saddle are properly adjusted before riding. Do not raise the seat post beyond the minimum insertion marking etched into the saddle post tube. If your saddle post projects from the frame beyond these markings, the saddle post or frame may break, which could cause you to lose control and fall. Prior to first use, be sure to tighten the saddle clamp properly. A loose saddle clamp or saddle post binding bolt can cause damage to the bicycle or can cause you to lose control or fall. Periodically check to make sure that the saddle clamp is properly tightened.

## Rider Comfort

To obtain maximum comfort, the rider should not overextend his or her arms reach when riding. To obtain the most comfortable riding position and offer the best possible pedaling efficiency, the saddle height should be set correctly in relation to the rider's leg length as briefly described above. The correct saddle height should not allow leg strain from over extension, and the hips should not rock from side to side when pedaling. While sitting on the bicycle with one pedal at its lowest point, place the ball of your foot on that pedal. The correct saddle height will allow the knee to be slightly bent in this position. A bicycle fitting professional should be consulted if you have any questions regarding proper bike fit to avoid strain on the rider.

## Battery Charging

### Basic Battery Charging Tips

- The battery should be recharged after each use. There is no memory effect so you can charge the battery after short rides without damage.
- The battery can be recharged on or off the bike.

- Remove the battery by turning the key and then pulling the battery forward and up until the battery lifts off the mating receptacle.
- The charger will automatically stop when the battery pack is full
- Always charge in dry locations and indoors away from direct sunlight, dirt or debris.
- Do not cover up the charger when plugged in or charging, it air cools and needs to be left in a clear space. Do not charge with the charger in the inverted position which can inhibit cooling and reduce the charger's life.
- Check the charger cables, charger and battery for damage before beginning each charge.
- The light on the charger will turn green when charge is complete and stay red while the battery charges
- Charging normally takes 3-5 hours, however it can take longer when you first receive the bike since the battery pack is balancing.
- Charge in a clear area away from potential to trip on the charging cords, or damage to occur to the bike, battery or charging equipment while parked.

## Charging Procedure

Follow these steps for charging your Rad Power Bike:

1. Turn the battery pack off using the key switch.
2. Remove the rubber cover on the charging socket on the opposite side of the battery switch.
3. With the battery on or off the bike, place the charger in a flat, secure place, and connect the DC output plug from the charger (round barrel connector) to the charging port on the side of the battery pack.
4. Then connect the input plug (110/220-volt plug) to the power outlet, charging should initiate and will be indicated by the LED charge status light on the charger turning red.
5. After charging, indicated by the charging indicator light turning green, unplug the charger from the wall outlet first and proceed to remove the charger output plug from the bike charging port.



Always charge your battery in temperatures between 50 and 80-degree Fahrenheit and ensure the battery and charger are not damaged before initiating charge. If you notice anything unusual while charging, please discontinue charging and use of the bike and contact Rad Power Bikes for help.



### When the Battery Is Removed

- Do not touch the “+” and “-” terminal contacts on the bottom of the battery when the battery is removed from the bike.
- Be careful not to drop or damage the battery pack when loose from the bike.

### When Installing the Battery onto the Bike

- Do not force the battery onto the receptacle, slowly align and push battery down into the receptacle.
- Ensure the key is in the locked position before riding and check that the battery has been properly secured to the bike before each use by pulling upwards and testing the security of the pack.

### Charging Time

When the input and output terminal are connected properly, and the battery is not fully charged, the red charging indicator light should illuminate, showing that the battery is charging. The time that the battery takes to fully charge the battery is dependent on various factors including distance traveled, riding characteristics, terrain, payload, and battery age. The following table provides an estimate of charge time based on most common distances traveled in regular operation:

Distance Traveled	Charge Time to Fully Recharge
8 km	1 hour
16 km	1.5 hours
24 km	2.5 hours
32 km	3.5 hours
40 km	4.5 hours
48 km	5.5 hours

**Notice:** The battery pack can take longer to charge when fully depleted and when the battery is new. As your battery ages, you might also experience increased charging times but this is only expected after 3-5 years of regular use. If your battery does not seem to be charging normally, and taking longer to charge than expected, please discontinue charging and contact Rad Power Bikes immediately.

### Charger Safety Information

- Keep charger in a safe place away from children.
- Fully charge the battery before each use to extend the life of the battery and help to reduce the chance of over-discharging the battery pack.
- Do not charge the battery with any other chargers than what was originally supplied with your Rad Power Bike or a charger purchased directly from Rad Power Bikes for use with your specific bike serial number, as approved by Rad Power Bikes.
- The charger works on 110/220 V 50/60 Hz standard home AC power outlets, do not open the charger to select voltage input, the charger automatically detects and accounts for incoming voltage.
- Avoid charger contact with liquids, dirt/debris or metal objects.
- Store the charger in a location where it cannot suffer damage from falls/impact.
- The charger should only be used indoors in a dry ventilated space.
- If you notice a strange smell or the charger or battery are overheating, please stop charging and contact Rad Power Bikes.

- Do not yank or pull on the cables of the charger. When unplugging carefully remove both the AC and DC cables by way of pulling on the plastic plugs, not pulling on the cables.



**Please take special care in charging of your Rad Power Bike in accordance with the above procedures and safety information. Failure to follow proper charging procedures can result in damage to your Rad Power Bike, charger, personal property and/or serious injury or death.**

## Operation

### Start-Up Procedure

After the bike has been properly assembled following the unboxing video and all components are secured correctly, you may now proceed to start up the vehicle and select the power level following the next steps.

1. Install the key and secure the battery pack to the frame mount, turning in the clockwise direction until you reach the “on” position. Remove the key and test to see the battery cannot be removed before proceeding.
2. Hold down the center mode button on the display remote for 2 seconds then release, the display should turn on.
3. Select your desired level of pedal assistance between level 0 through 5 using the up and down arrows on the display remote. Level 1 corresponds to the lowest level of pedal assistance, and level 5 corresponds to the highest level of pedal assistance. Level 0 indicates pedal assistance will be inactive.
4. To turn on the headlight once the LCD display are on, hold down the top and middle button located on the left side of the handlebars for 2-3 seconds.
5. With the proper safety gear and rider knowledge and understanding you may now proceed to operate your Rad Power Bike. You can begin by pedaling the bike in the appropriate drivetrain gear with or without pedal assistance. You may also use the throttle to accelerate and maintain your desired speed.
6. The throttle is used by first ensuring the black button that is part of the throttle assembly is depressed, and then slowly and carefully applying the throttle by rotating the throttle backwards towards the rider. If the button on the throttle is not depressed, the throttle will not be active. Do not use the throttle unless you are on the bike. The black

button on the throttle is a latching type switch, so once you have it depressed, you do not need to hold it down. With the button depressed, the throttle can be used whenever the bike is turned on.



**NOTICE:** Even if you are an experienced bicycle user, please take the time to read and implement the guidelines described in the owner’s manual accompanying your Rad Power Bike, online resources at [radpowerbikes.com](http://radpowerbikes.com) and the manuals included with each sub component.

**NOTICE:** Do not perform any of the steps in the Operation section of this manual until you have read this entire manual since there are important details in the following sections, especially related to safety.



**Users must become accustomed to the bikes power control system before operating. The throttle mechanism allows full power to be activated from a stop and inexperienced users should take extra care when first applying the throttle. The pedal assistance feature is also a powerful option and users should fully research and understand how to operate it before first use. Not taking care to familiarize yourself and practice the operation of the power system on your Rad Power Bikes can lead to death or serious injury, please heed this warning.**





Users must follow the instructions and warnings contained in this manual for their safety. Do not attempt to operate your Rad Power Bike until you have attained adequate knowledge of its control and operation. Damage caused by failing to follow instructions is not covered under warranty and could result in personal injury to you or others as well as damage to property and/or your Rad Power Bike. Contact Rad Power Bikes if you have any questions about assembly or operation.

## Display Features

The image shows the various features and information displayed on the wireless remote. The display is controlled using the 3-button remote mounted on the left side of the handlebar. For more information on the LCD display and operation please refer to the SW-LCD manual.

## Driving Range

The range of your Rad Power Bike is the distance the bike will travel on a single full charge of the onboard battery pack. The range values in this manual are estimates based on expected usage characteristics. Some of the factors which effect range include changes in elevation, speed, payload, and acceleration, number of starts and stops and ambient air temperatures. Tire pressure and terrain are also important variables to consider.

We suggest that you ride conservatively when you first get your Rad Power Bike to get to know your bike and travel routes. Once you become familiar with the range requirements of your travel routes, and the capabilities of your Rad Power Bikes you can then adjust you riding characteristics if you so desire.

The following table provides general estimates and outlines various factors effecting range and their combined estimated effects on range. This table is meant to help owners understand the factors that can increase of decrease range but Rad Power Bikes makes no claims to the range that individual users might obtain.



Expected Range	Operating Conditions
32 km	<ul style="list-style-type: none"> <li>○ Hilly Terrain</li> <li>○ Heavy Payload</li> <li>○ Windy</li> <li>○ High Speeds</li> <li>○ Light Pedaling</li> </ul>
48 km	<ul style="list-style-type: none"> <li>○ Flat Terrain</li> <li>○ Normal Payload</li> <li>○ Not Windy</li> <li>○ Medium Speeds</li> <li>○ Light Pedaling</li> </ul>
64 km	<ul style="list-style-type: none"> <li>○ Flat Terrain</li> <li>○ Normal Payload</li> <li>○ Not Windy</li> <li>○ Low Pedal Assist Level</li> <li>○ Moderate to Heavy Pedaling</li> </ul>

### Battery Capacity Display

The LCD readout on the handlebar of your Rad Power Bike features a battery capacity gauge (much like the fuel gauge on an automobile). It is recommended that users stop operating the bike once one bar is left on the display. Once the battery is fully depleted, the last remaining bar will begin to flash, communicating to the user that they should cease operation immediately.

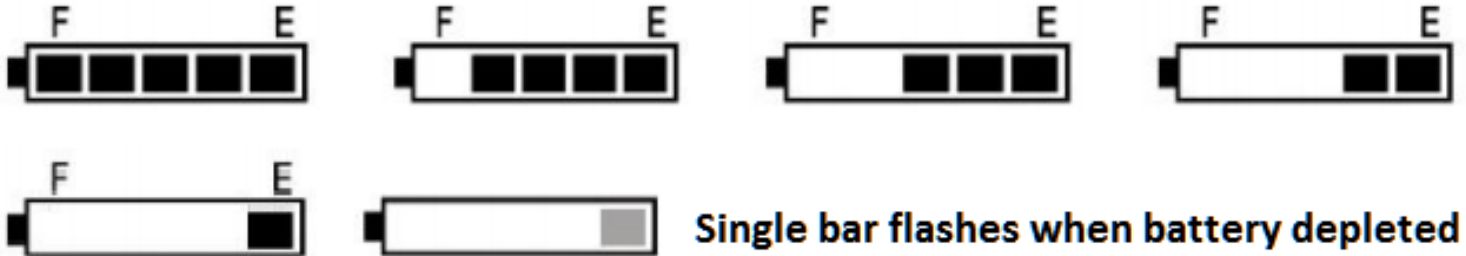

## Best Practices for Extending Range and Battery Life

**Notice:** It is recommended that users pay close attention and ride within the following limitations to ensure the hub motor does not overheat or become damaged from excessive loading.

- Do not climb hills steeper than 15% in grade.
- Pedal to assist the motor when climbing hills and accelerating from a stop.
- Avoid sudden starts and stops.
- When climbing hills reduce the power output when possible. This can be accomplished by pedaling with the bike while in pedal assist modes 1 or 2.
- Accelerate slowly.

## Parking, Storage and Transport

Please follow these basic parking, storage and transport tips to ensure your bike is well cared for on and off the road.

- When pushing the vehicle manually, turn off the power to avoid accidental acceleration from the motor.
- It is recommended to park indoors.
- Switch the power off, and any lights to conserve battery. Remove the key from the bike and ensure the battery is locked to the frame or removed and brought with you for security.
- In public places, your Rad Power Bike must be parked in accordance with local rules and regulations.
- If you must park outdoors in rain, or wet conditions you should only leave your Rad Power Bike outside for a few hours and proceed to park the bike in a dry location afterwards to allow all the systems to dry out. Much like a regular bike, use in wet conditions mandates a more regular maintenance schedule to ensure your bike does not become rusty, corroded and to ensure all systems are always working safely.
- Do not park, store, or transport your Rad Power Bike on a rack that is not designed for the size and weight of the bike.
- Wide tires, as used on Rad Power Bikes, cannot fit into all bike racks, please select an appropriate rack for the width of tires used on your bike.

- Locking up your bike is recommended to ensure your bike is secure and the chance of theft is reduced. Rad Power Bikes makes no claims or recommendations on the proper lock hardware or procedures to secure your bike, but we do recommend you take the appropriate precautions to keep your Rad Power Bike safe from theft.
- When storing your bike or carrying your bike on a rack for transport, you can remove the battery pack to reduce the weight of the bike and make lifting and loading easier.

## Regenerative Braking

Regenerative braking is active on the RadWagon whenever the front and/or rear brake lever is applied. There is an electronic switch in the brake lever and when it is applied, the electric hub motor will turn into a brake. This feature recharges the battery pack when coming to a stop and travelling downhill.



**The force of the motor acting as a brake allows the bike to slow down more rapidly compared to a standard bicycle; because of this you should proceed with caution and practice using this helpful feature before traveling on public streets and downhill routes.**

## Carrying Loads and Passengers

### MAXIMUM PAYLOAD FOR RADWAGON

The total maximum weight limit of the RadWagon (158 Kilograms) includes the weight of the rider as well as clothing, riding gear, cargo, other riders, etc. The kickstand is not designed to be used for loading cargo. You **MUST** hold onto the bike whenever loading cargo, especially when loading precious cargo and children. Do not assume the bike is stable and balanced when using the kickstand, always hold onto the bike when cargo is being loaded or in place.

Total payload: 158 Kilograms

Rear Rack: 54 Kilograms including all cargo, accessories and passengers

Running Boards: 18 Kilograms per side

Kickstand: 45 Kilograms

## CARRYING CHILDREN

The use of certified and approved child seating and equipment is required whenever carrying children. Rear wheel guards must be in place whenever carrying passengers to ensure feet and hands do not contact moving wheels. Ensure hands and feet are kept away from wheels at all times the bike is in motion. Check all regulations in the area where you operate the RadWagon to ensure carrying passengers, children, or cargo is allowed. Follow the stated weight limits in the section above, do not overload the RadWagon. The RadWagon should never be operated by persons under the age of 18 years old. Children incapable of riding a bike independently or under the age of four should not ride as passengers on the back of the RadWagon unless they are seated in a properly fitted and approved Child Safety Seat.

The RadWagon rear rack is equipped with mounting windows for the Thule Yepp Maxi Easyfit child carrier. For installation instructions, safety notices, general information and tips on safe operation of this accessory, visit the manufacturer's website online at <https://www.thule.com/>

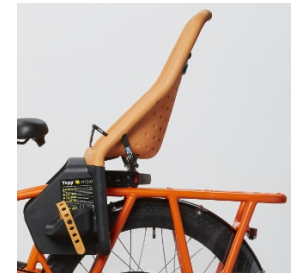

**Notice:** The following bulleted list provides important additional tips for the safe operation of the RadWagon when used for carrying children and other passengers.

- Do not allow passengers to sit sideways or backwards on the rear deck.
- Do not allow passengers to stand or kneel on the rear deck, or running boards.
- Increased weight from passengers will increase the time it takes to slow the bike when braking, please plan your stops accordingly. Ensure both front and rear brakes are properly adjusted and maintained.
- When carrying passengers 4 years old or above you must have the running boards, rear wheel side covers and an appropriate handlebar, also known as a stoker handlebar. As mentioned above, children incapable of riding a children's bike should not ride as passengers, use your best judgement as a parent or guardian.
- Hold onto your bicycle when loading and ensure that your passengers are safely seated before beginning to ride.
- If using a single child carrier, it is advised that you mount it in the forward most mounting position, to ensure passenger weight is as centered as possible.
- That you and your passengers are wearing a properly fitted and approved helmet.
- Since passengers sit behind you they cannot see bumps or upcoming turns so instruct your passengers to brace for bumps and be prepared for turns and other maneuvers.
- Passengers should sit directly over or forward of the rear wheel on the back deck, and no more than 40 pounds should be loaded over the rear 1/3<sup>rd</sup> of the back deck.



**Never leave the bike unattended with children on the bicycle. Ensure children are removed from the bike before you look away or walk away from the bike, otherwise the bike could tip over and cause serious injury to your most precious cargo.**



**Do not remove the clear rear wheel side covers from your RadWagon. These help to keep hands and feet away from the moving wheels. Contact with the rear wheel can cause injury and damage to occur.**



**The kickstand is not designed to be used for loading cargo. You MUST hold onto the bike whenever loading cargo, especially when loading precious cargo and children. Do not assume the bike is stable and balanced when using the kickstand, always hold onto the bike when cargo is being loaded or in place.**



It is the user's responsibility to ensure the passengers loaded on the RadWagon do not interfere or impact their ability to safely operate the RadWagon at all times. Serious injury or death can occur if passengers or cargo impact the user's ability to safely operate the RadWagon.



It is the user's responsibility to ensure the passengers on the RadWagon are adequately experienced and healthy enough to safely ride as passengers. Serious injury or death can occur if passengers are inexperienced, in poor health or fitness which could impact their ability in riding as passengers.

### Carrying Cargo

Carrying a cargo load involves additional risks which need to be paid close attention to, users should practice riding on a flat and open area with light cargo before attempting to carry heavier loads or passengers. You must become accustomed to the braking, steering, and operational adjustments required to safely operate the RadWagon with cargo. Braking, acceleration, and balancing are all significantly affected by the addition of cargo loaded on the RadWagon.

**Notice:** The following bulleted list provides important tips for the safe operation of the RadWagon when used for carrying cargo.

- Plan your route accordingly as your hill climbing ability, steering and braking are all impacted when cargo is loaded on the RadWagon. Hills that are normally easy to climb and descend without cargo can become challenging and dangerous once cargo is loaded.
- Cargo should be loaded as low as possible to lower the center of gravity and improve stability, but ensure that cargo does not interfere with any moving components or the ground.
- Ensure your loads are properly secured and periodically check that nothing loosens.
- Get a feel for the cargo load in a flat and open area before riding on roads.



**Do not use the front brake by itself, always apply the rear brake first followed by the front brake and be sure to use both brakes for all braking operations. Front fork failure or loss of control are plausible when the front brake is operated independently for slowing at high speed with cargo loads.**



**Do not remove the clear rear wheel side covers from your RadWagon. These help to keep straps and cargo away from the moving wheels. Contact with the rear wheel can cause injury and damage to occur.**



**The kickstand is not designed to be used for loading cargo. You MUST hold onto the bike whenever loading cargo, especially when loading precious cargo and children. Do not assume the bike is stable and balanced when using the kickstand, always hold onto the bike when cargo is being loaded or in place.**

## Maintenance

### Bicycle Care

To ensure safe riding conditions you must properly maintain your bike. You should follow these basic guidelines and see your certified local bike shop seasonally to ensure your bike is safe for use.

7. Properly maintain batteries by keeping them fully charged when not in use.
8. Never immerse the bike or any components in water as the electrical system may be damaged.
9. Periodically check wiring and connectors to ensure there is no damage and the connectors are secure.
10. To clean, wipe the frame with a damp cloth soaked in a mild non-corrosive detergent mixture. Dry with a cloth.
11. Store under shelter; avoid leaving it in the rain or exposed to corrosive materials. If exposed to rain, dry your bicycle afterwards and apply anti-rust treatment to chain and other unpainted steel surfaces.
12. Riding on the beach or in coastal areas exposes your bicycle to salt which is very corrosive. Wash your bicycle frequently and wipe or spray all unpainted parts with anti-rust treatment. Damage from corrosion is not covered under warranty so special care should be given to extend the life of your bike when used in coast areas or areas with salty air or water.



13. If the hub and bottom bracket bearings have been submerged in water they should be taken out and re-greased. This will prevent accelerated bearing deterioration.
14. If the paint has become scratched or chipped in the metal, use touch up paint to prevent rust. Clear nail polish can also be used as a preventative measure.
15. Regularly clean and lubricate all moving parts, tighten components and adjust as required.
16. The RadWagon comes equipped with a full fender set as well as a rear rack, both of which should be inspected to ensure mounting hardware is properly secured and these parts are in good working condition.



**Your cables, spokes and chain will stretch after an initial break in period of 80-160 km, while bolted connections can loosen. Therefore, always have a certified bicycle mechanic perform a tune-up on your RadWagon after your initial break-in period of 80-160 km (depending on total weight, riding characteristics and terrain). Regular inspections and tune-ups are particularly important for ensuring that your bicycle remains safe and problem-free.**

## Safety Checklist

**Notice:** Before every ride it is important to carry out the following safety checks.

Safety Check	Basic Steps
1. Brakes	<ul style="list-style-type: none"> <li>○ Ensure front and rear brakes work properly.</li> <li>○ Ensure brake pads are not over worn and are correctly positioned in relation to the rims.</li> <li>○ Ensure brake control cables are lubricated, correctly adjusted and display no obvious wear.</li> <li>○ Ensure brake control levers are lubricated and tightly secured to the handlebars.</li> </ul>
2. Wheels and Tires	<ul style="list-style-type: none"> <li>○ Ensure tires are inflated to within the recommended limits displayed on the tire sidewalls.</li> <li>○ Ensure tires have tread and have no BULGES OR EXCESSIVE WEAR.</li> <li>○ Ensure rims run true and have no obvious wobbles or kinks.</li> <li>○ Ensure all wheel spokes are tight and not broken.</li> </ul>

	<ul style="list-style-type: none"> <li>○ Check axle nuts and quick releases to ensure they are tight. If your bicycle is outfitted with quick release axles, ensure the locking levers are correctly tensioned and in the closed position.</li> </ul>
3. Steering	<ul style="list-style-type: none"> <li>○ Ensure handlebar and stem are correctly adjusted and tightened, and allow proper steering.</li> <li>○ Ensure the handlebars are set correctly in relation to the forks and the direction of travel.</li> </ul>
4. Chain	<ul style="list-style-type: none"> <li>○ Ensure the chain is oiled, clean and runs smoothly.</li> <li>○ Extra care is required in wet or dusty conditions</li> </ul>
5. Bearings	<ul style="list-style-type: none"> <li>○ Ensure all bearings are lubricated, run freely and display no excess movement, grinding or rattling.</li> <li>○ Check headset, wheel bearings, pedal bearings and bottom bracket bearings.</li> </ul>
6. Cranks and Pedals	<ul style="list-style-type: none"> <li>○ Ensure pedals are securely tightened to the cranks.</li> <li>○ Ensure the cranks are securely tightened and are not bent.</li> </ul>
7. Derailleurs	<ul style="list-style-type: none"> <li>○ Check that the derailleur(s) are adjusted and functioning properly.</li> <li>○ Ensure shift and brake levers are attached to the handlebar securely.</li> <li>○ Ensure all brake and shift cables are properly lubricated.</li> </ul>
8. Frame and Fork	<ul style="list-style-type: none"> <li>○ Check that the frame and fork are not bent or broken. If either are bent or broken, they should be replaced.</li> </ul>
9. Accessories	<ul style="list-style-type: none"> <li>○ Ensure all reflectors are properly fitted and not obscured.</li> <li>○ Ensure all other fitting on the bike are properly secured and functioning.</li> <li>○ Ensure rider is wearing helmet and any other required riding safety gear.</li> </ul>
10. Motor Drive Assembly and Throttle	<ul style="list-style-type: none"> <li>○ Ensure hub motor is spinning smoothly and the motor bearings are in good working order.</li> <li>○ Ensure all power cables running to hub motor are secured and undamaged.</li> <li>○ Make sure the hub motor axle bolts are secured and all torque arms and torque washers are in place.</li> </ul>
11. Battery Pack	<ul style="list-style-type: none"> <li>○ Ensure battery is charged before use.</li> <li>○ Ensure there is no damage to battery pack.</li> <li>○ Lock battery to frame and check to see that it is secured.</li> </ul>
12. Fenders	<ul style="list-style-type: none"> <li>○ Ensure fender mounting hardware is properly secured.</li> <li>○ Ensure there are no cracks or holes in fenders.</li> </ul>

# Troubleshooting

## Basic Troubleshooting

	Symptoms	Possible Causes	Most Common Solutions
1	<b>It doesn't work</b>	<ol style="list-style-type: none"><li>1. Insufficient battery power</li><li>2. Faulty Connections</li><li>3. Battery not fully seated in tray</li><li>4. Improper turn on sequence</li><li>5. Brakes are applied</li></ol>	<ol style="list-style-type: none"><li>1. Charge the battery pack</li><li>2. Clean and repair connections</li><li>3. Install battery correctly</li><li>4. Turn on bike with proper sequence</li><li>5. Disengage brakes</li></ol>
2	<b>Irregular acceleration and/or reduced top speed</b>	<ol style="list-style-type: none"><li>1. Insufficient battery power</li><li>2. Loose or damaged throttle</li></ol>	<ol style="list-style-type: none"><li>1. Charge or replace battery</li><li>2. Replace throttle</li></ol>
3	<b>When powered on the motor does not respond</b>	<ol style="list-style-type: none"><li>1. Loose wiring</li><li>2. Loose or damaged throttle</li><li>3. Loose or damaged motor plug wire</li><li>4. Damaged motor</li></ol>	<ol style="list-style-type: none"><li>1. Repair and or reconnect</li><li>2. Tighten or replace</li><li>3. Secure or replace</li><li>4. Repair or replace</li></ol>
4	<b>Reduced range</b>	<ol style="list-style-type: none"><li>1. Low tire pressure</li><li>2. Low or faulty battery</li><li>3. Driving with too many hills, headwind, braking, and/or excessive load</li><li>4. Batter discharged for long period of time without regular charges, aged or damaged.</li></ol>	<ol style="list-style-type: none"><li>1. Adjust tire pressure</li><li>2. Check connections or charge battery</li><li>3. Assist with pedals or adjust route</li><li>4. Replace the battery</li></ol>
5	<b>The battery won't charge</b>	<ol style="list-style-type: none"><li>1. Charger not well connected</li><li>2. Charger damaged</li><li>3. Battery damaged</li><li>4. Wiring damaged</li></ol>	<ol style="list-style-type: none"><li>1. Adjust the connections</li><li>2. Replace</li><li>3. Replace</li><li>4. Repair or replace</li></ol>
6	<b>Wheel or motor makes strange noises</b>	<ol style="list-style-type: none"><li>1. Damaged motor bearings</li><li>2. Damaged wheel spokes or rim</li><li>3. Damaged motor wiring</li></ol>	<ol style="list-style-type: none"><li>1. Replace</li><li>2. Repair or replace</li><li>3. Repair or replace motor.</li></ol>

## Error Detection

Your Rad Power Bike is equipped with an error detection system integrated into the LCD display and motor controller. In the case of an electronic control system fault an error code should display. The following error codes are the most common and can aid in troubleshooting. If your bike has an error code displayed at any time it is recommended that you cease operation and contact Rad Power Bikes immediately.

Error Code	Definition
21	Abnormal Current
22	Throttle Fault
23	Motor Phase Problem
24	Motor Hall Defect
25	Brake Failed or Brake Applied While Turning On
30	Abnormal Communication

## Wiring Diagram

The basic wiring diagram of the complete electronic system (left) and display (right) are meant for use in basic diagnostics or troubleshooting with the help of a Rad Power Bike technical support agent.

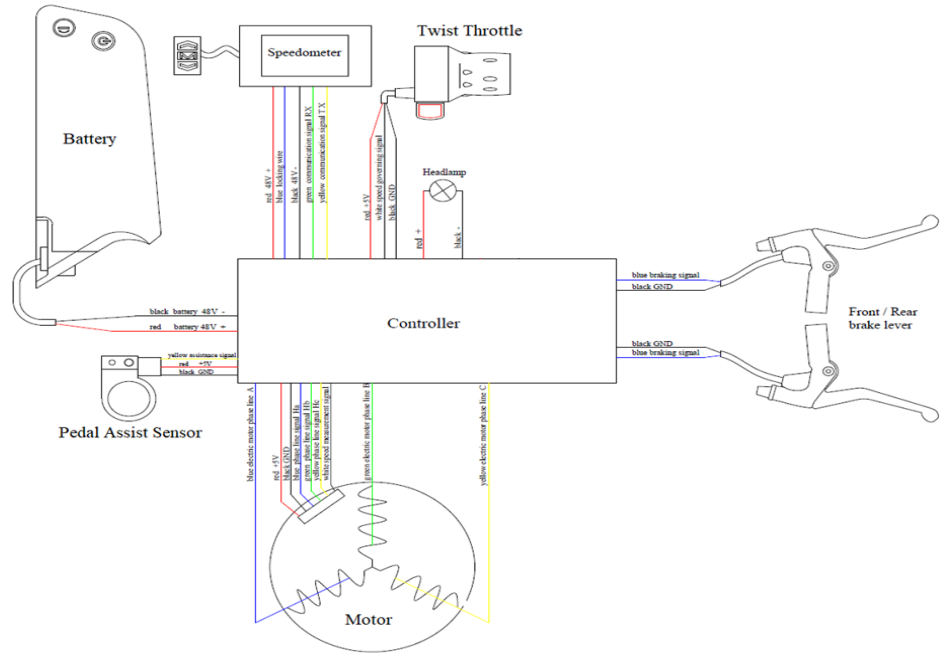

## Warnings and Safety

### General Warnings



Like any sport bicycling involves risk of injury and damage. By choosing to ride a bicycle, you assume the responsibility for that risk, so you need to know, and practice the rules of safe and responsible riding and the proper use and maintenance of this bicycle. Proper use and maintenance of your bicycle reduces risk over injury.



Your bicycle is designed for use by person 18 years old and above.



Riders must have the physical condition, reaction time and mental capability to ride and manage traffic, road conditions, and sudden situations and respect the laws governing electric bicycle use where they ride, regardless of age. If you have an impairment or disability such as a visual impairment, hearing impairment, physical impairment, cognitive/language impairment, or a seizure disorder, consult your physician before riding any bicycle.

### General Operating Rules

**Notice:** It is recommended that users pay special attention to all the general operating rules below before operating their Rad Power Bike.

- When riding obey the same road laws as all other road vehicles. Including giving way to pedestrians and stopping at red lights and stop signs.
- For additional information, contact the road traffic authority, police department or Department of Motor Vehicles in your state.
- Ride predictably and in a straight line. Never ride against traffic.
- Use correct hand signals to indicate turning or stopping.
- Ride defensively. To other road users you may be hard to see.
- Concentrate on the path ahead. Avoid potholes, gravel, wet or oily roads, curbs, train tracks, speed bumps, drain gates, and other obstacles.
- Cross train tracks at a 90-degree angle or walk your bicycle across.

- Expect the unexpected such as opening car doors or cars backing out of driveways.
- Be careful at intersections and when preparing to pass other vehicles or other cyclists.
- Familiarize yourself with all the bicycles features. Practice shifting gears, using the brakes and power system.
- If you are wearing loose pants, secure the bottom using leg clips or elastic bands to prevent them from being caught in the chain or gears. Wear proper riding clothes and avoid wearing open toe shoes.
- Don't carry passengers or cargo that will interfere with your ability to control the bicycle. Don't use items that may restrict your hearing.
- Do not lock up the brakes. When braking, apply the rear brake first, then the front brake. The front brake is more powerful and if it is not correctly applied, you may lose control and fall.
- Maintain a comfortable stopping distance from all other objects, riders, and vehicles. Safe braking distances are based on forces such as weather and light conditions among other variables.

## Wet Weather



**It is recommended to not ride in wet weather. Ride in wet weather only if necessary.**

This electric bicycle is not meant for use in puddles, heavy rain, and streams. Never immerse this product in water as the electrical system may be damaged.

- In wet weather you need to take extra care when operating this bicycle.
- Brake earlier since it will take longer to slow then when operated in dry conditions.
- Decrease riding speed.
- Be more visible on the road.
- Wear reflective clothing and use approved safety lights.
- Road hazards are more difficult to see when wet, proceed with caution.



**It is recommended to not ride at night. Ride at night only if necessary.**

- Ensure your Rad Power Bike is equipped with a full set of correctly positioned and clean reflectors.
- Use a properly functioning lighting set comprised of a white front lamp and red rear lamp.
- If using battery powered lights, make sure batteries are charged and carry an extra set of batteries for lights and lights.
- Use flashing rear lights to increase visibility.
- Wear reflective and light-colored clothing.
- Slow down and use familiar roads with street lighting, if possible.

## Tire Inflation and Replacement

The RadWagon uses 26"x2.3" rubber tires with inner tubes. The tires are designed for durability and safety for regular cycling activities however tires need to be checked before each use for proper inflation and condition. Proper inflation, care and timely replacement will help to ensure that your bikes operational characteristics will be maintained and unsafe conditions avoided.

Rad Power Bikes recommends **3.45-4.13 bar (50-60 PSI)** for the front and rear tires on the RadWagon.



**It is critically important that proper air pressure is maintained in pneumatic tires at all times. Do not underinflate or overinflate your tires. Low pressure may result in loss of control, and overinflated tires may burst. Failure to maintain the air pressure rating indicated on pneumatic tires at all times may result in tire and/or wheel failure.**



**Inflate your tires from a regulated air source with an available pressure gauge. Inflating your tires from an unregulated air source could overinflate them, resulting in a burst tire.**



**When tire wear becomes evident or a flat tire is discovered, you must replace the tires and/or tubes before operating the bike or injury to operators and/or damage to your bike could occur.**



**To prevent serious injury, ensure that all air pressure has been removed from the inner tube prior to removing tire from the rim.**



**Using aftermarket tires or inner tubes, not provided by Rad Power Bikes may void your warranty, create an unsafe riding condition or damage to your Rad Power Bike.**

For more information on tire or tube replacement procedures, or questions about tire inflation, visit the Rad Power Bikes website and contact Rad Power Bikes technical support.

### [A Note for Parents and Guardians](#)

As a parent or guardian, you are responsible for the activities and safety of your child. The RadWagon is not designed for use by children. If you are carrying a passenger in a child safety seat, they must also be wearing a helmet. Additional safety information regarding helmets follows in the Helmet section of this manual.

### [Safety Notes](#)



**The following safety notes provide additional information on the safe operation of your Rad Power Bike and should be closely reviewed. Failure to review these notes can lead to serious injury or death.**

- All users must read and understand this manual before first use. Additional manuals for components used on your bicycle may also be provided and should be read before use in addition to this manual.
- Ensure that you comprehend all instruction and safety notes/warnings.
- Ensure the bike fits you properly before first use. You may lose control or fall if your bike is too big or too small.
- Always wear an approved bicycle helmet whenever using this product and ensure that all helmet manufacturer instructions are used for fit and care of your helmet. Failure to wear a helmet when riding may result in serious injury or death.
- Ensure correct tightening and setup is performed on your bicycle before first and checked regularly.



- It is your responsibility to familiarize yourself with the laws and requirements of operation of this product in the area(s) where you ride.
- Ensure handle bar grips are not damaged and properly installed. Loose or damaged grips can cause you to lose control and fall.
- Do not use this product with standard bicycle trailers, stands or bicycle racks. Contact Rad Power Bikes to check if your equipment will work with the bicycle.
- Off-road riding requires close attention and specific skills and presents variable conditions and hazards which accompany the conditions. Wear appropriate safety gear and do not ride alone in remote areas.
- Engaging in extreme riding is extremely dangerous and should be avoided. Although many articles/advertisements/catalogues depict extreme riding this is not recommended nor permitted and you can be seriously injured or killed if you perform extreme riding.
- Bicycles and bicycle parts have strength and integrity limitations and extreme riding should not be performed or you risk damaging the components or becoming seriously injured or killed.
- Failure to confirm proper installation, compatibility, proper operation or maintenance of and component or accessory can result in serious injury or death.
- After any incident you must consider your bike unsafe to ride until you consult with a certified bicycle service provider for a comprehensive inspection.
- Failure to properly charge, store or use your battery will void the warranty and may cause a hazardous situation.
- Extreme care should be taken when using the pedal assist sensor and propulsion on this product. Ensure you understand and are prepared for the power assistance to engage as soon as pedaling is underway.
- You should check the operation of the brake inhibitor switches before each ride. The brake system is equipped with an inhibitor which shuts down the power to the electric motor whenever the brakes are engaged. Check proper operation of brake switches before riding.
- User must understand the operation of the twist throttle and pedal assist sensors before using, and take ample care in their usage in respect to traveling at speeds appropriate for usage area and user experience level. Always use the lowest assist level until you are comfortable with the bike and feel confident in controlling the power.
- Any aftermarket changes to your Rad Power Bike not expressly approved by Rad Power Bikes could void the warranty and create an unsafe riding experience.
- Because electric bicycles are heavier and faster than normal bicycles, they require extra caution and care while riding.
- Take extra care while riding in wet conditions. Feet or hands can slip in wet conditions and lead to death or serious injury from a fall.

- Do not remove front or rear reflectors, pedal reflectors or bell.

## Helmets

It is strongly advised that a properly fitting ANSI or SNELL approved bicycle safety helmet be worn at all times when riding your bicycle.

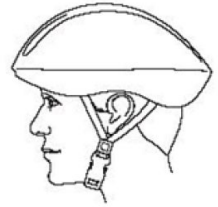

**Always wear a properly fitted helmet which covers the forehead when riding a bicycle. Many states require specific safety devices. It is your responsibility to familiarize yourself with the laws of the state where you ride and to comply with all applicable laws, including properly equipping yourself and your bike as the law requires. Reflectors are important safety devices which are designed as an integral part of your bicycle. Federal regulations require every bicycle to be equipped with front, rear, wheel, and pedal reflectors. These reflectors are designed to pick up and reflect street lights and car lights in a way that helps you to be seen and recognized as a moving bicyclist. Check reflectors and their mounting brackets regularly to make sure they are clean, straight, unbroken and securely mounted. Have your dealer replace damaged reflectors and straighten or tighten any that are bent or loose.**

## Link to Assembly Video and Online Resources

### Assembly Video

Please visit the support section of the Rad Power Bikes website to view the official 2018 RadWagon Assembly Video. [www.radpowerbikes.com](http://www.radpowerbikes.com)

### Online Resources

Please visit the Rad Power Bikes website at <http://www.radpowerbikes.com> for more information or to contact us.

## Limited Warranty

### Warranty Info

Every bike is covered under a manufacturer's one-year warranty for the original owner against all manufacturing defects. Rad Power Bikes warrants this product, including all individual components against defects in material or workmanship as follows:

## RAD POWER BIKES LIMITED 1 YEAR WARRANTY

Rad Power Bikes' bicycle components including frame, forks, stem, handlebar, headset, seat post, saddle, brakes, lights, bottom bracket, crank set, pedals, rims, spokes, wheel hub, freewheel, cassette, derailleur, shifter, motor, throttle, controller, wiring harness, LCD display, kickstand, reflectors and hardware are warranted to be free from manufacture defects in materials and/or workmanship for a 1-year period from the date of original purchase.

Wear and tear is not covered under warranty. Rad Power Bikes' lithium ion batteries are warranted to be free from manufacturing defects in materials and/or workmanship for a 1-year period from the date of original purchase. The battery warranty does not include damage from power surges, use of improper charger, improper maintenance or other such misuse, normal wear or water damage.

### The Following Are Also Excluded from the Warranty

- Liability for material defects does not cover normal wear which occurs from the manufacturers intended use of the product. Components such as the battery pack, motor system, braking system, drivetrain system, saddle, grips and pedals are all subject to intended use-related wear and are not covered under the warranty from normal wear.
- Damage arising from the use of the bike in a competition or other applications outside of normal intended use.
- Damage arising by the use of improper tools or inadequate maintenance performed on the bike.
- Damage resulting from adding non-standard equipment, parts or technical modifications.

### Additional Warranty Terms

This warranty does not cover any damage or defects resulting from failure to follow instructions in the owner's manual, acts of God, accident, misuse, neglect, abuse, commercial use, alterations, modification, improper assembly, wear and tear, installation of parts or accessories not originally intended or compatible with the bicycle as sold, operator error, water damage, extreme riding, stunt riding, or improper follow-up maintenance. This warranty only applies to the original owner of a Rad Power Bikes bicycle. This warranty does not apply to rental or commercial use bicycles. This warranty is expressly limited to the replacement of defective parts at the sole discretion of Rad Power Bikes. This warranty does not include consumables

or normal wear and tear parts (tires, tubes, brake pads, cables and housing, grips). Rad Power Bikes will not be liable and/or responsible for any damage, failure or loss caused by any unauthorized service or use of unauthorized parts. In no event shall Rad Power Bikes be responsible for any direct, indirect or consequential damages, including without limitation, damages for personal injury, property damage, or economic losses, whether based on contract, warranty, negligence, or product liability in connection with their products. All claims to this warranty must be made through Rad Power Bikes. Proof of purchase may be required with any warranty request.

### Additional Information on Wear

Components of the RadWagon are subject to higher wear when compared to bicycles without power assistance. This is because the RadWagon can travel at higher average speeds than regular cycles and has a greater weight. Higher wear is not a defect in the product and is not subject to warranty. Typical components affected are the tires, brake pads, suspension forks, spokes/wheels and battery pack.



**When the useful life of a component is surpassed it can cause unexpected loss of function. This can result in serious injuries or even death. Therefore, pay attention to wear characteristics such as cracks, scratches or changes in the color or operation of components which could indicate useful life has been exceeded. Worn components should be immediately replaced.**

**We are here to help! Please contact us at [support@radpowerbikes.com](mailto:support@radpowerbikes.com) or 1-800-939-0310 if you have questions**

**Thanks for Riding RAD!**