

# FHP

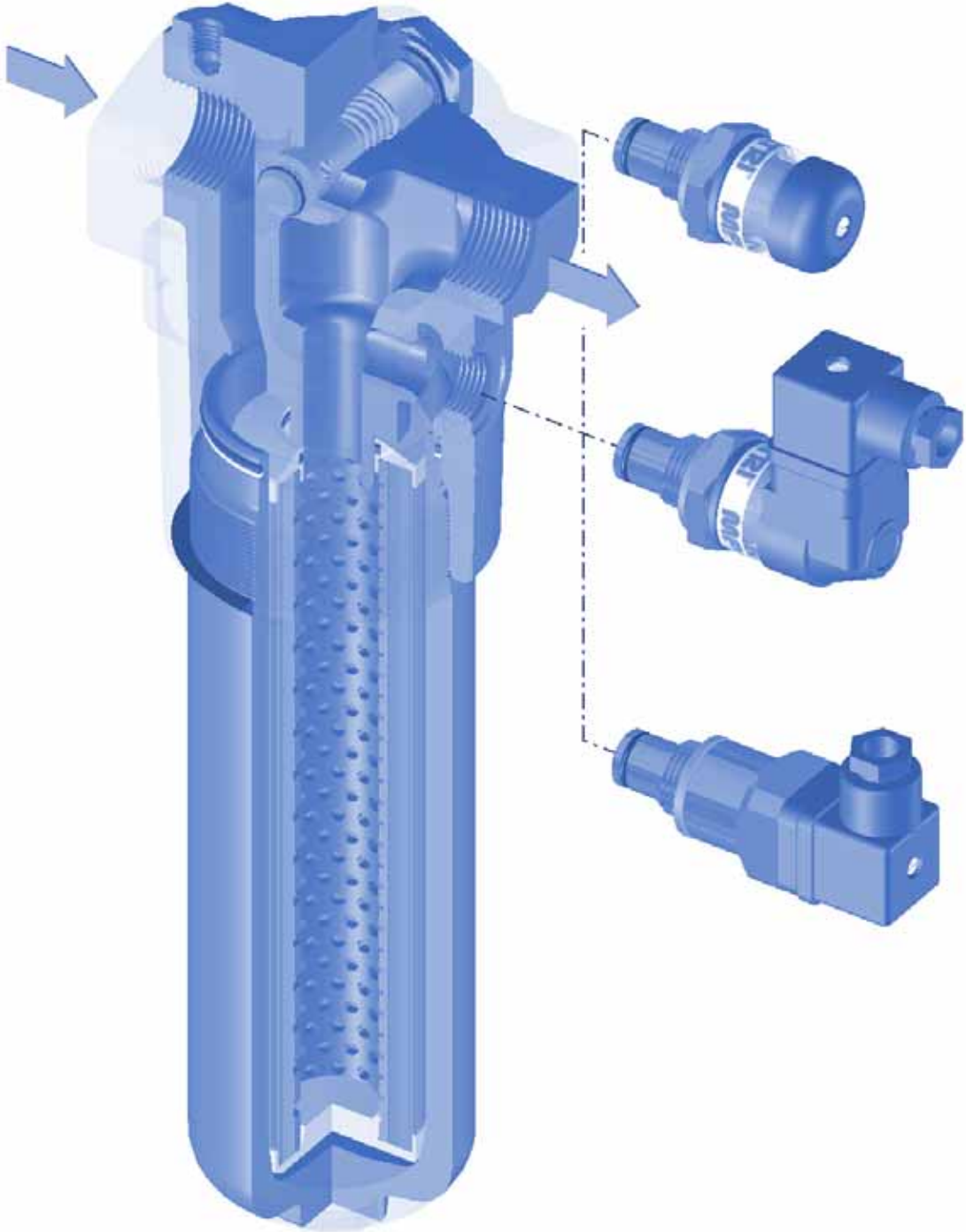

# SERIES FHP

Working pressure  
420 bar



Style S

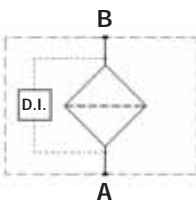

Style B

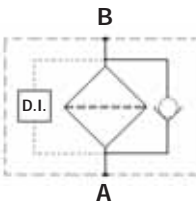

Style T

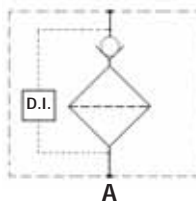

Style D

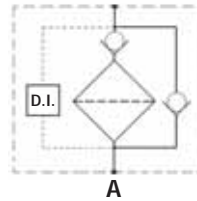

Style V

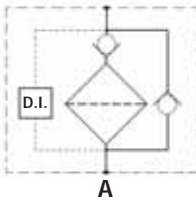

Style Z

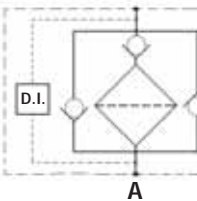

# Technical data

## Filter body (Materials)

- Head: Cast iron (chemical heat treatment)
- Housing: Steel (chemical heat treatment)
- Bypass valve: Brass
- Reverse Flow: Steel (only for series 320)

## Pressure

- Maximum operating pressure: 420 bar (42 MPa)
- Test pressure: 630 bar (63 MPa)
- Burst pressure: 1250 bar (125 MPa)
- Pulsed pressure fatigue test 1,000,000 of cycles with pressure from 0 to 420 bar (42 MPa)

## Temperature

- From -25°C to +110°C

## Bypass valve

- Opening pressure 6 bar  $\pm$ 10%
- Other opening pressures on request.

## Elements type $\Delta p$

- Elements in microfibre series N-R: 20 bar
- Elements in microfibre series H-S: 210 bar
- Elements in stainless steel mesh series N: 20 bar
- Oil flow from exterior to interior.

## Seals

- Standard Nitrile (NBR) series A
- Optional FPM series V

## Weights without filter elements (kg.)

Length	1	2	3	4
• FHP 065	3.9	4.2	5.7	—
• FHP 135	7.5	9.4	12	—
• FHP 320/321	14.5	16.5	22.5	25.5

## Filter internal volumes (dm<sup>3</sup>)

Length	1	2	3	4
• FHP 065	0.35	0.40	0.60	—
• FHP 135	0.55	0.85	1.20	—
• FHP 320/321	1.25	1.95	2.80	3.50

## Connections

In-line Inlet/Outlet  
Style FHP 321 inlet/outlet 90°

## Compatibility

- Bodies compatible with:  
Mineral oils to ISO 2943 - aqueous emulsions  
Synthetic fluids, water/glycol.
- Filter elements compatible with:  
Mineral oils to ISO 2943 - aqueous emulsions  
Synthetic fluids, water/glycol.
- Nitrile (NBR) seals series A, compatible with:  
Mineral oils to ISO 2943 - aqueous emulsions  
Synthetic fluids, water/glycol.
- V series FPM seals, compatible with:  
Synthetic fluids type HS-HFDR-HFDS-HFDU.  
To ISO 2943

## Filter Element Area

Filter element in stainless steel mesh  
Length

Type	1	2	3	4
HP065	374	530	1064	-
HP135	950	2020	2700	-
HP320	1650	3645	5970	8280

Values expressed in cm<sup>2</sup>

## Pressure drops $\Delta p$ Housing

The curves are plotted using mineral oil with density of 0.86 kg/dm<sup>3</sup> to ISO 3968.

$\Delta p$  varies proportional with density.

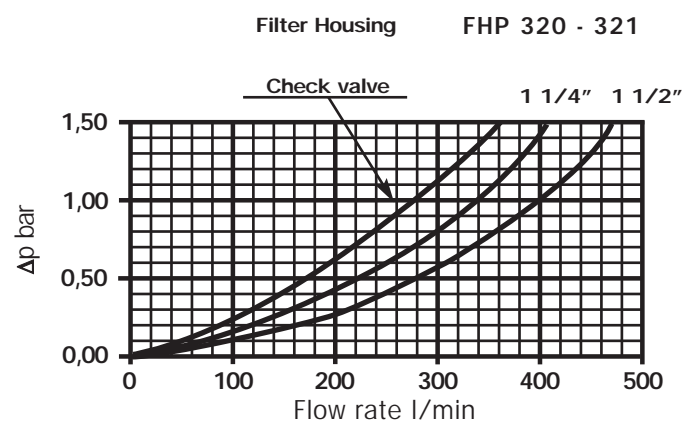
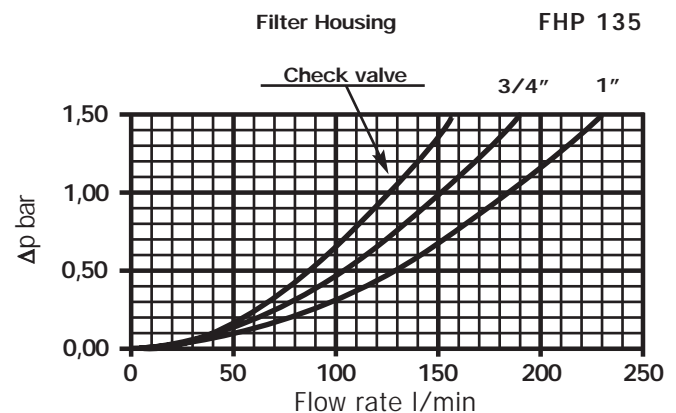
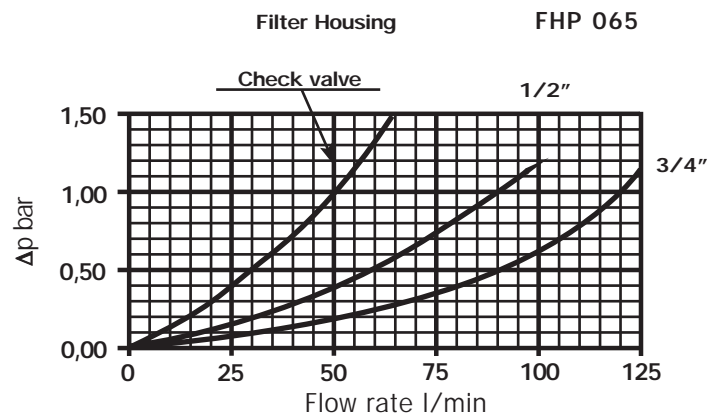

# Valves

## Pressure drop in bypass valve

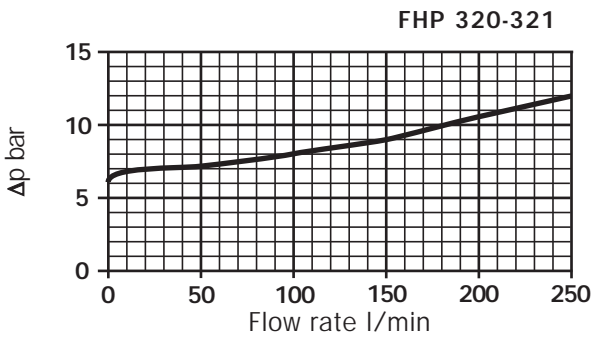
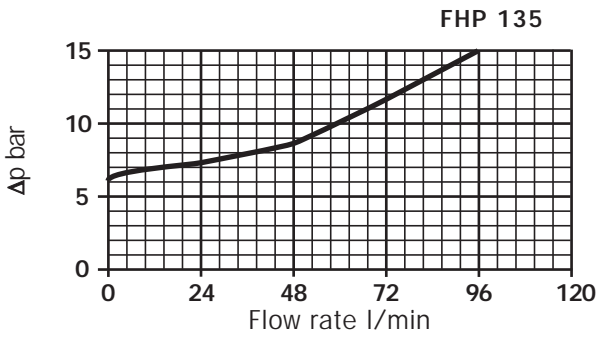
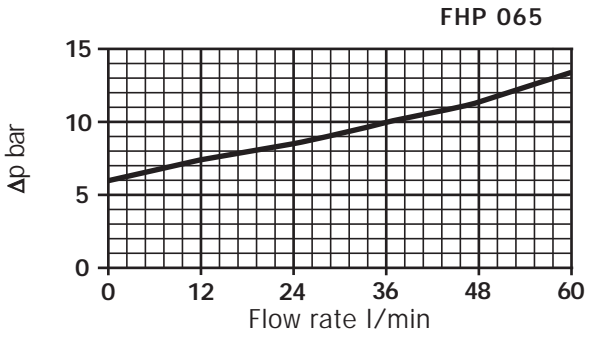

## Pressure drop in reverse flow valves

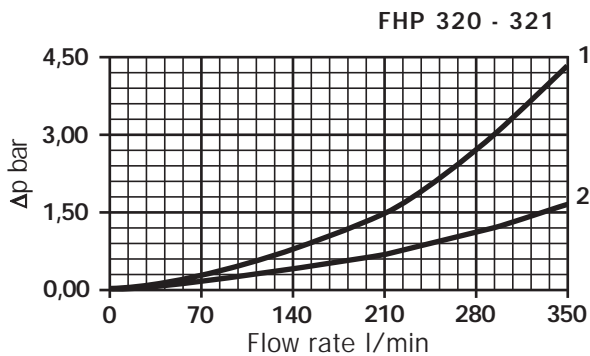

- 1 - Reverse Flow
- 2 - In filter direction

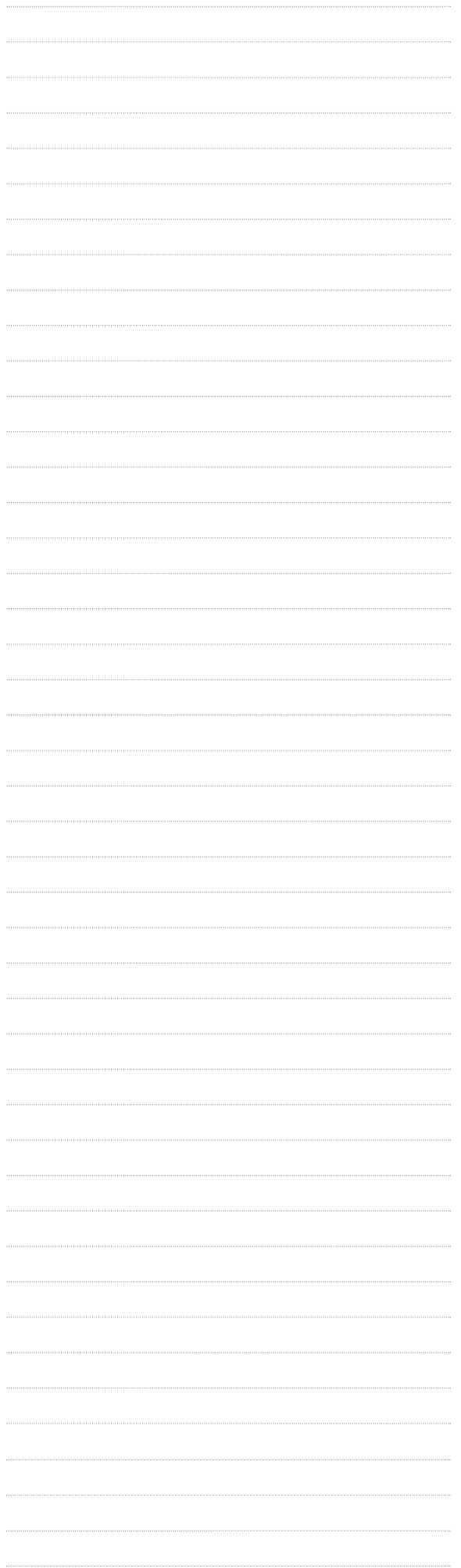

## FHP065

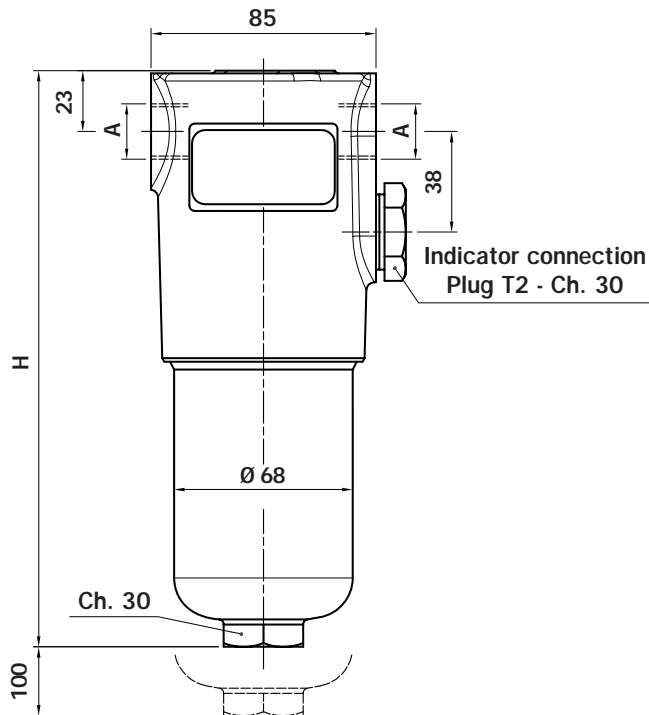

### Recommended maximum flow rate

- Pressure drop of complete filter equal to  $\Delta p$  1.5 bar.
- Oil kinematic viscosity 30 mm<sup>2</sup>/s (cSt).
- Density 0.86 kg/dm<sup>3</sup>.
- Connections of filter under test G 3/4".

Filter element type	Flow rate l/min Series N	Flow rate l/min Series H	Filter Length
A03	23	22	1
A06	30	23	
A10	48	43	
A16	53	50	
A25	72	68	
M25	105	-	2
A03	31	30	
A06	45	35	
A10	60	57	
A16	64	63	
A25	82	77	3
M25	106	-	
A03	53	52	
A06	61	58	
A10	79	78	
A16	84	83	3
A25	94	93	
M25	108	-	

A Threaded Connections	E Depth 15 mm
G 1/2"	M8
G 3/4"	M8
1/2" NPT	5/16" UNC
3/4" NPT	5/16" UNC
SAE 8 (3/4" - 16 UNF)	5/16" UNC
SAE 12 (1 1/16" - 12 UN)	5/16" UNC

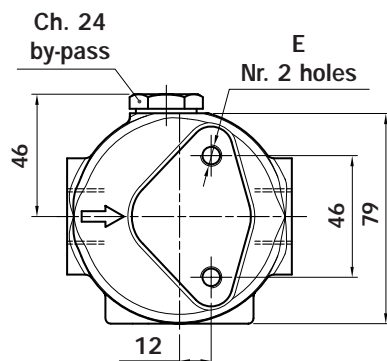

Filter Length	H mm
1	200
2	230
3	330

# FHP135

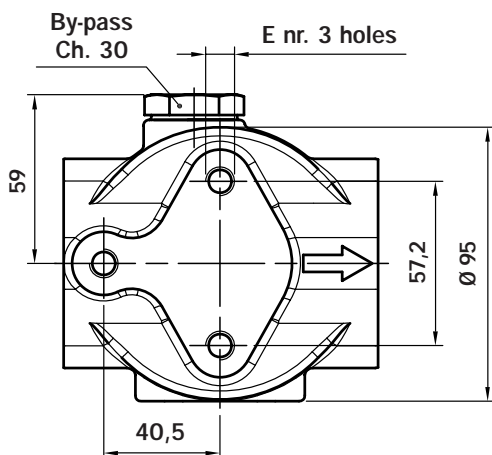
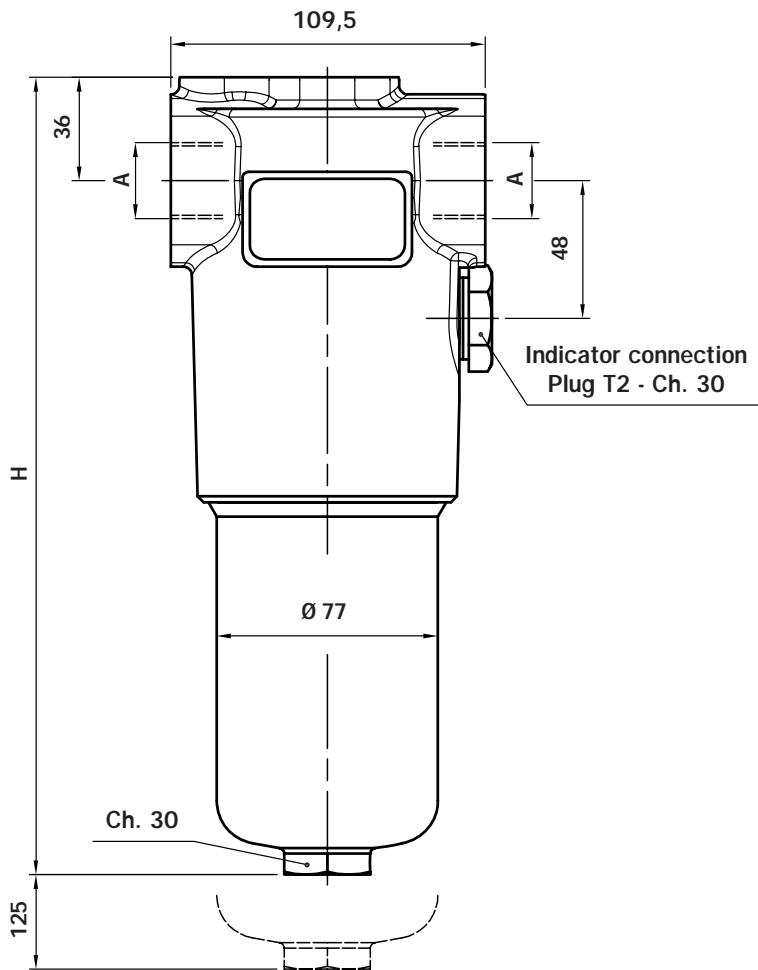

## Recommended maximum flow rate

- Pressure drop of complete filter equal to  $\Delta p$  1.5 bar.
- Oil kinematic viscosity 30 mm<sup>2</sup>/s (cSt).
- Density 0.86 kg/dm<sup>3</sup>.
- Connections of filter under test G 1".

Filter element type	Flow rate l/min Series N	Flow rate l/min Series H	Filter Length
A03	69	50	1
A06	74	57	
A10	120	98	
A16	129	101	
A25	171	156	
M25	200	-	
A03	110	91	2
A06	117	110	
A10	148	136	
A16	151	139	
A25	208	175	
M25	230	-	
A03	150	126	3
A06	153	140	
A10	192	170	
A16	195	179	
A25	213	196	
M25	232	-	

A Threaded Connections	E Depth 15 mm
G 3/4"	M10
G 1"	M10
3/4" NPT	3/8" UNC
1 NPT	3/8" UNC
SAE 12 (1 1/16"- 12 UN)	3/8" UNC
SAE 16 (1 5/16"- 12 UN)	3/8" UNC

A Flanged Connections	E Depth 15 mm
3/4" SAE 3000 psi/M	M10
1" SAE 3000 psi/M	M10
3/4" SAE 3000 psi/UNC	3/8" UNC
1" SAE 3000 psi/UNC	3/8" UNC
3/4" SAE 6000 psi/M	M10
3/4" SAE 6000 psi/UNC	3/8" UNC

Filter Length	H mm
1	260
2	373
3	448

# FHP320/321

Only for FHP 320 length 4

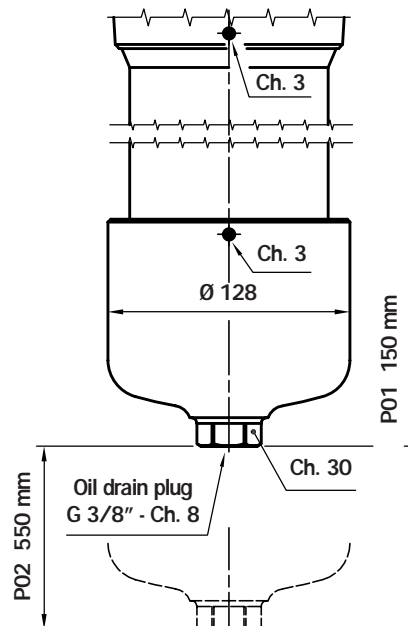
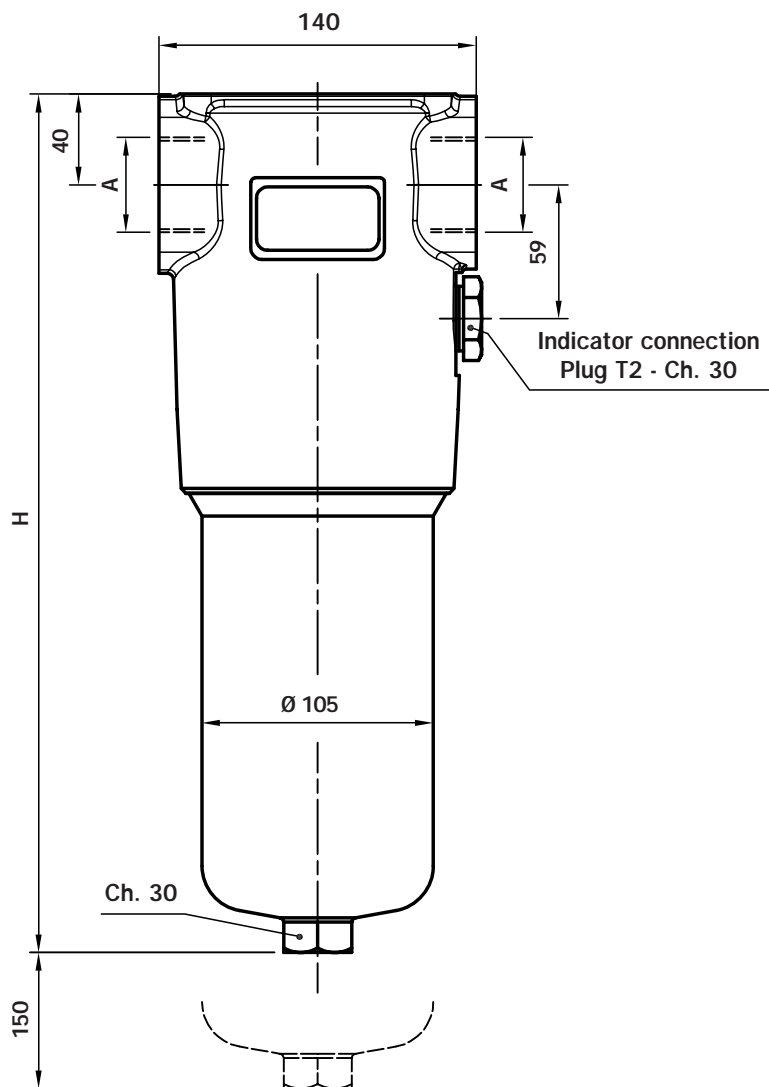

Style P01 standard maintenance from head.  
Style P02 maintenance option from housing base.

FHP 320

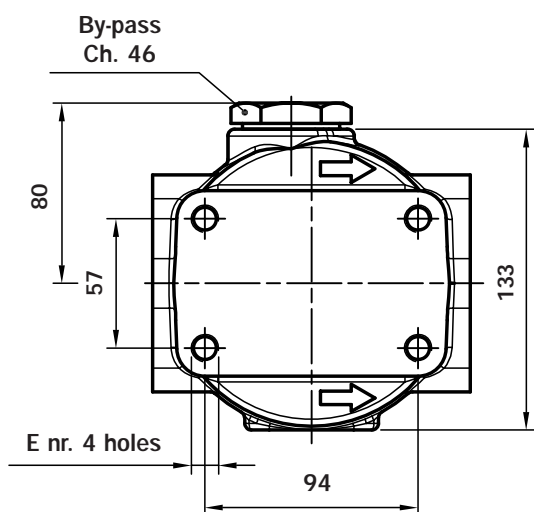

FHP 321  
Top Outlet

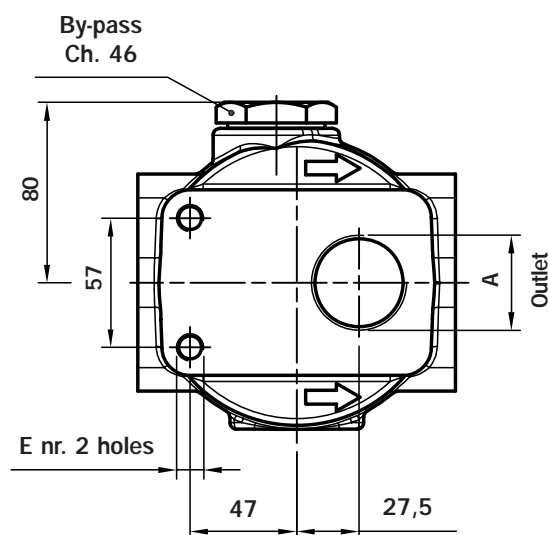

**Recommended maximum flow rate**

- Pressure drop of complete filter equal to  $\Delta p$  1.5 bar.
- Oil kinematic viscosity 30 mm<sup>2</sup>/s (cSt).
- Density 0.86 kg/dm<sup>3</sup>.
- Connections of filter under test G 1 1/2".

Filter element type	Flow rate l/min Series N	Flow rate l/min Series H	Filter Length
A03	126	107	1
A06	137	112	
A10	230	185	
A16	274	193	
A25	330	292	
M25	425	-	
A03	248	192	2
A06	270	220	
A10	376	300	
A16	395	312	
A25	440	378	
M25	445	-	
A03	319	255	3
A06	353	300	
A10	427	367	
A16	440	375	
A25	450	417	
M25	465	-	
A03	354	298	4
A06	375	320	
A10	430	375	
A16	447	382	
A25	467	422	
M25	475	-	

A Threaded Connections	E Depth 15 mm
G 1 1/4"	M12
G 1 1/2"	M12
1 1/4" NPT	1/2" UNC
1 1/2" NPT	1/2" UNC
SAE 20 (1 5/8"- 12 UN)	1/2" UNC
SAE 24 (1 7/8"- 12 UN)	1/2" UNC

A Flanged Connections (For FHP 320)	E Depth 15 mm
1 1/4" SAE 3000 psi/M	M12
1 1/2" SAE 3000 psi/M	M12
1 1/4" SAE 3000 psi/UNC	1/2" UNC
1 1/2" SAE 3000 psi/UNC	1/2" UNC
1 1/4" SAE 6000 psi/M	M12
1 1/4" SAE 6000 psi/UNC	1/2" UNC

Filter Length	H mm
1	298
2	422
3	554
4	709



# Spare parts FHP

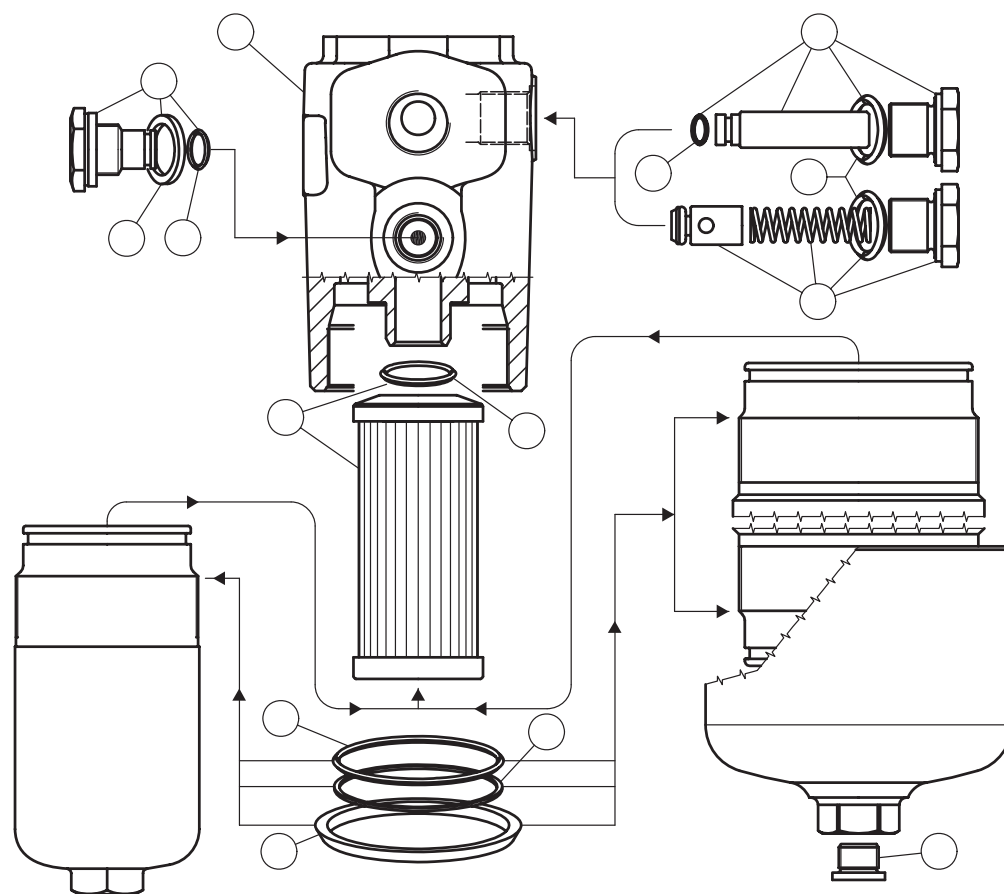

Pos.	Description	Qty.	FHP Series FILTER					
			065 1 - 2 - 3		135 1 - 2 - 3		320 1 - 2 - 3 - 4	
1	Complete filter	1	See order table					
2	Filter element	1	See order table					
3	Bypass assembly	1	02001116 (NBR) 02001136 (FPM)		02001117 (NBR) 02001137 (FPM)		02001118 (NBR) 02001138 (FPM)	
4	Non bypass assembly	1	02001142 (NBR) 02001139 (FPM)		02001143 (NBR) 02001392 (FPM)		02001144 (NBR) 02001395 (FPM)	
5	Seal kits	1	NBR 02050265	FPM 02050276	NBR 02050269	FPM 02050280	NBR 02050272	FPM 02050283
5a	Filter element O-Ring	1	OR 4100 Ø 24.99 x 3.53		OR 3106 Ø 26.65 x 2.62		OR 144 Ø 39.69 x 3.53	
5b	O-Ring for housing	1	OR 159 Ø 55.56 x 3.53		OR 3256 Ø 64.77 x 2.62		2 pcs.	OR 3350 Ø 88.57 x 2.62
5c	Anti-extrusion ring	1	Parbak 227 Ø 54.53 x 3		Parbak 144 Ø 63.96 x 2.18		2 pcs.	Parbak 153 Ø 89.36 x 2.18
5d	Gasket	1	01030058 (HNBR)	01030046 (FPM)	01030058 (HNBR)	01030046 (FPM)	01030058 (HNBR)	01030046 (FPM)
5e	O-Ring	1	O-R 2050 Ø 12.42 x 1.78					
5f	Bp or Non Bp O-Ring	1	OR 121 Ø 15.88 x 2.62		OR 3087(NBR 90 Sh A) Ø 21.89 x 2.62		OR 3143 (NBR 90 Sh A) Ø 36.14 x 2.62	
5g	Bp or Non Bp O-Ring	1	OR 2031 Ø 7.65 x 1.78		OR 2037 Ø 9.25 x 1.78		OR 2081 Ø 20.35 x 1.78	
5h	Protective seal	1	01026521		01026509		01026510	
5m	Drain plug	1					G 3/8" with seal	
6	Indicator plug	1	T2H			T2V		
-	Indicators	1	See order table					

# Ordering information FHP

## Filter assembly FHP

Example: FHP

1	2	3	4	5	6	7	8a
<input type="text"/>	<input type="text"/>	<input type="text"/>	<input type="text"/>	<input type="text"/>	<input type="text"/>	<input type="text"/>	<input type="text"/>
135	1	S	A	G1	A03	H	P01

## Filter element HP

Example: HP

1	2	4	6	7	8b
<input type="text"/>	<input type="text"/>	<input type="text"/>	<input type="text"/>	<input type="text"/>	<input type="text"/>
135	1	A	A03	H	P01

### 1 - Size

065
135
320
321

### 2 - Filter length

1
2
3
4

(only for FHP 320-321)

### 3 - Valves

S
B
D
V
Z
T

Without bypass

With bypass

With bypass + chek valve\*

With Reverse Flow\*  
(only for FHP 320)

With Reverse Flow + bypass  
(only for FHP 320)

With bypass + chek valve\*  
(only for FHP 320)

\*Reduced cross-section oilways

### 4 - Seals

A
V

NBR

FPM

### 5 - Connections

Type	065	135	320	321
G1	G 1/2"	G 3/4"	G 1 1/4"	G 1 1/4"
G2	G 3/4"	G 1"	G 1 1/2"	G 1 1/2"
G3	1/2" NPT	3/4" NPT	1 1/4" NPT	1 1/4" NPT
G4	3/4" NPT	1" NPT	1 1/2" NPT	1 1/2" NPT
G5	SAE 8	SAE 12	SAE 20	SAE 20
G6	SAE 12	SAE 16	SAE 24	SAE 24
F1	-	3/4" SAE 3000 PSI/M	1 1/4" SAE 3000 PSI/M	-
F2	-	1" SAE 3000 PSI/M	1 1/2" SAE 3000 PSI/M	-
F3	-	3/4" SAE 3000 PSI/UNC	1 1/4" SAE 3000 PSI/UNC	-
F4	-	1" SAE 3000 PSI/UNC	1 1/2" SAE 3000 PSI/UNC	-
F5	-	3/4" SAE 6000 PSI/M	1 1/4" SAE 6000 PSI/M	-
F6	-	3/4" SAE 6000 PSI/UNC	1 1/4" SAE 6000 PSI/UNC	-

### 6 - Filter elements

A03
A06
A10
A16
A25
M25

Inorganic microfibre 3 µ

Inorganic microfibre 6 µ

Inorganic microfibre 10 µ

Inorganic microfibre 16 µ

Inorganic microfibre 25 µ

Stainless steel mesh 25 µ (style N only)

$\beta_x (c) \geq 1000$

See page 10

### 7 - Filter elements differential pressure

N
H

20 bar

210 bar

R
S

(Filter with Reverse Flow + bypass)

(Filter with Reverse Flow)

### 8 - Options

#### a) Filter

P01
P02
Pxx

MP Standard filters

Maintenance from base of housing (FHP 320 - 4 only)

Customer request

#### b) Filter element

P01
Pxx

MP Filtri standard

Customer request

DIFFERENTIAL INDICATORS  
(see page 15)

MP Filtri - The filter functions as described in this bulletin are valid exclusively for original MP Filtri filter elements and replacement parts. All rights reserved

The data in this publication is marketing information. MP Filtri reserves the right to make changes to the product described herein at any time it deems fit in relation to technical or commercial requirements. The colors of the products shown on the cover are for illustration purposes only.

Copyright. All rights reserved.