

EATON

Char-Lynn

Hydraulic Motor

T Series
General Purpose Geroler® Motor

001

Repair Information

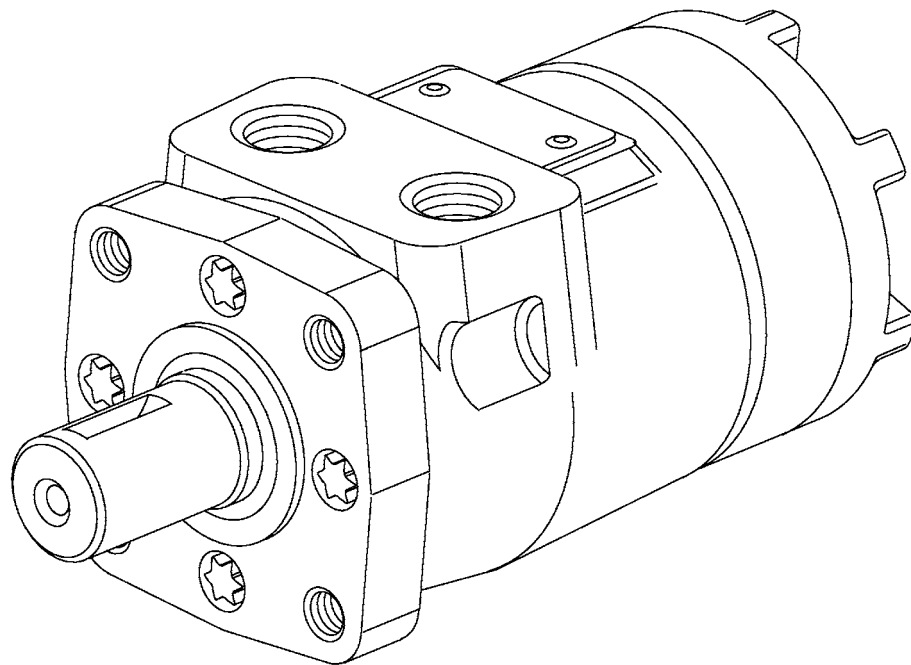

Parts Drawing

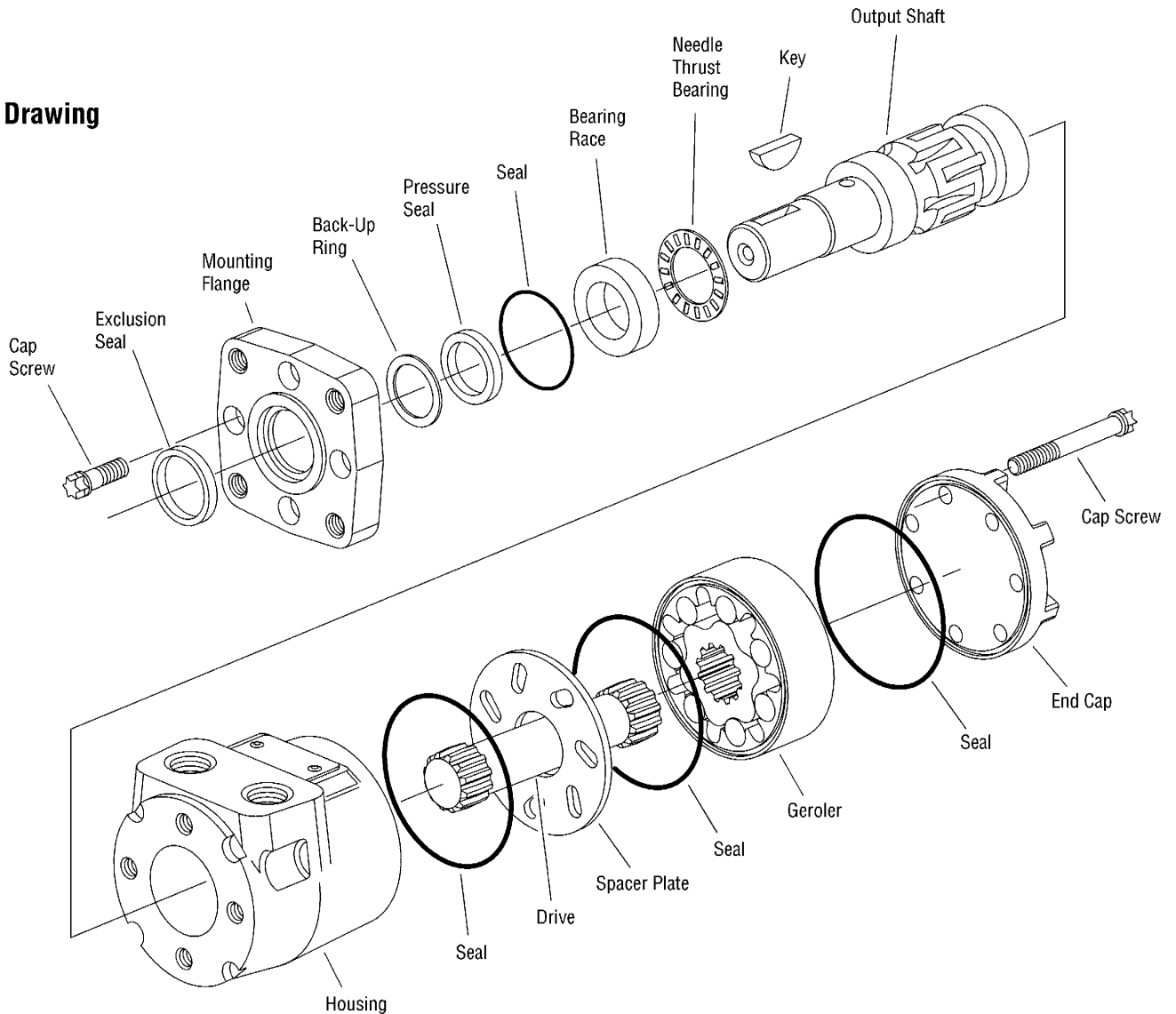

Tools Required

- Torque wrench (34 Nm [300 lb-in] capacity)
- 300 - 400 mm [12 - 16 in.] breaker bar
- 5/16 in. – 6 point (E10 Drive) socket no. 64489-000* (Heavy Duty 56 Nm [500 lb-in] capacity)
- Small blade screwdriver
- 3/16 in. hex key
- Shaft seal installation tool P/N 600523*
- Shaft sleeve or bullet
 - P/N 600304* for 1 inch dia. shaft
 - P/N 600466* for 7/8 inch dia. shaft

*Tools available, through Eaton order entry department.

T Series Geroler Motors

Disassembly

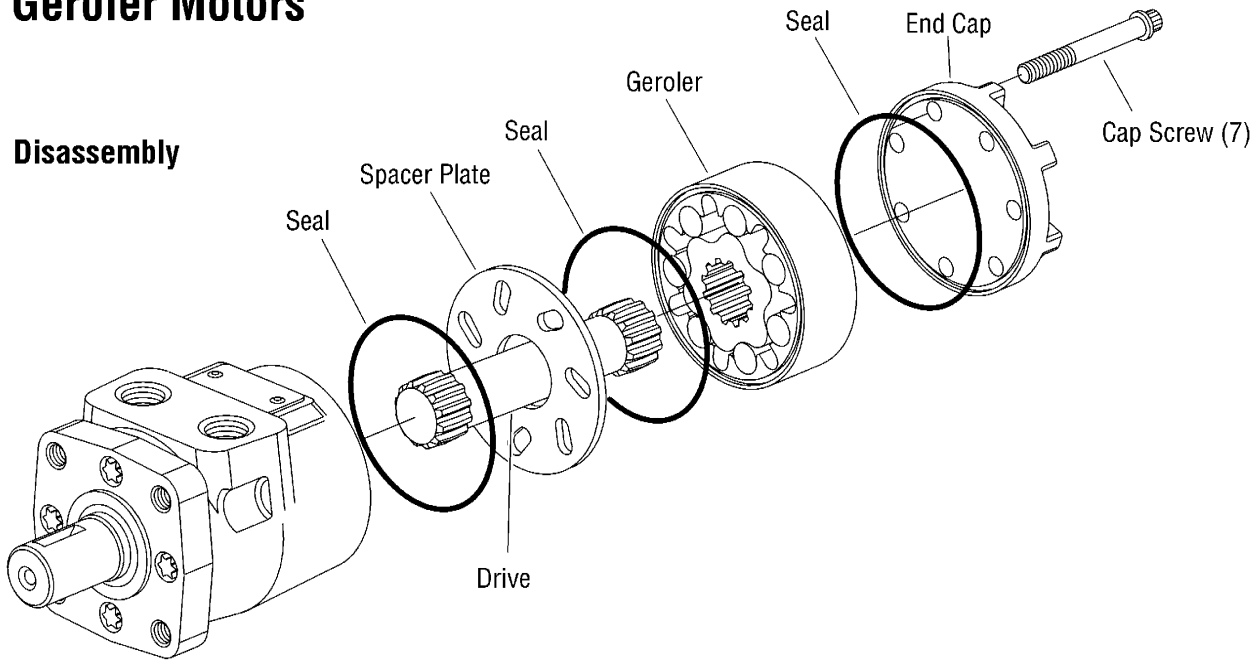

Figure 1

Cleanliness is extremely important when repairing hydraulic motors. Work in a clean area. Before disconnecting the hydraulic lines, clean the port area of the motor. Before disassembly, drain the oil from the motor. Then plug the ports and thoroughly clean the exterior of the motor. Check the output shaft, remove any burrs, nicks, or sharp edges.

1 Clamp the motor in a vise so the shaft is vertical and the end cap is on top. Clamp on the mounting flange using just enough clamping force to hold the motor securely. Protect the mounting flange with soft vise jaws.

2 Remove the seven cap screws from the end cap and disassemble the motor as shown in Figure 1. Do not disassemble the Geroler.

3 Un-clamp the motor and remove the output shaft, thrust needle bearing, and thrust bearing race (see Figure 2).

4 Clamp the motor in a vise so the mounting flange is on top. Clamp across the port area. **Do not clamp on the motor housing.** Use just enough clamping force to hold the motor securely.

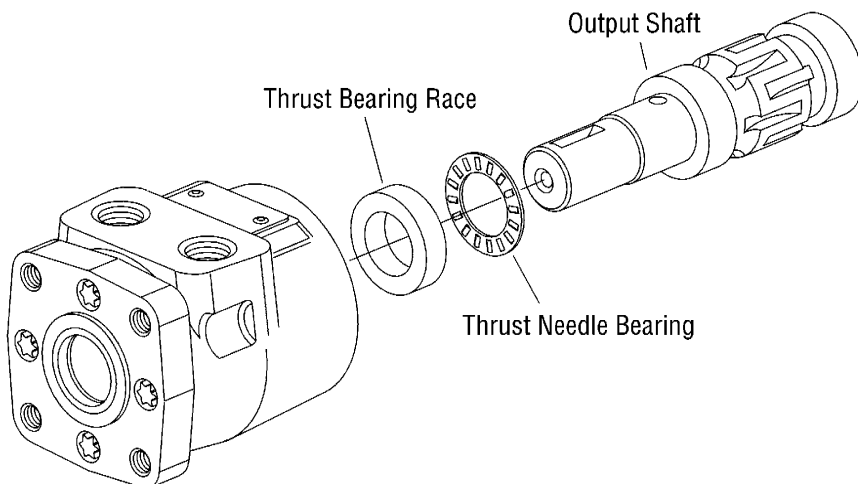

Figure 2

Disassembly

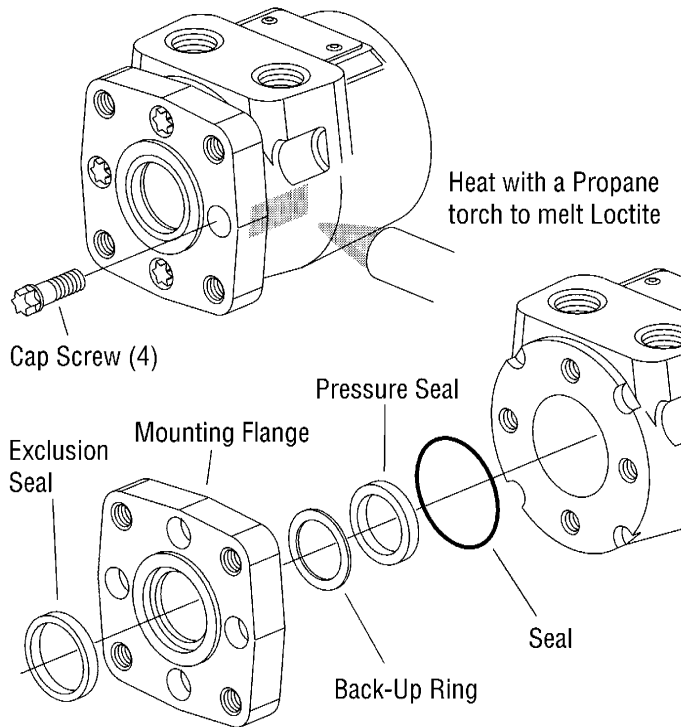

Figure 3

5 Remove the four cap screws that hold the mounting flange to the motor housing.

Caution: These screws were Loctited during assembly. **Do Not exceed 56 Nm [500 lb-in] of removal torque.**

If the Loctite is holding the screws too tightly, heat the motor housing, with a propane torch, while turning the screw. Apply heat to where the screw threads into the motor housing, see figure 3. Apply just enough heat to remove the screw, do not overheat the motor housing or mounting flange.

6 Remove the mounting flange from the motor housing. The exclusion seal, pressure seal, and back-up ring will come off with the mounting flange.

7 Carefully remove the exclusion seal, pressure seal, and back-up ring from the mounting flange. A seal removal tool may be fabricated by bending and rounding the end of a small blade screwdriver, see figure 4.

Important: Do not damage the mounting flange where the shaft passes through it.

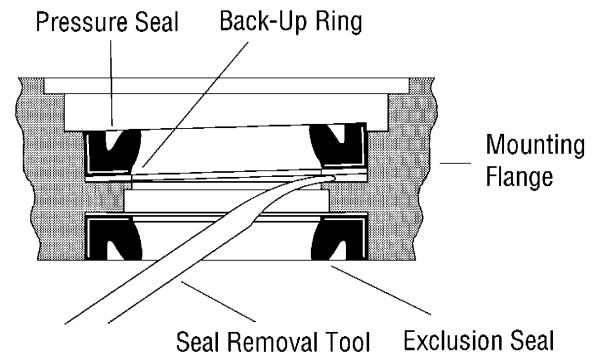

Figure 4

Reassembly

Check all mating surfaces. Replace any parts with scratches or burrs that could cause leakage. Wash all metal parts in clean solvent. Blow them dry with pressurized air. Do not wipe parts dry with paper towels or cloth as lint in a hydraulic system will cause damage. Check the key way and chamfered area of the output shaft; remove any nicks, burrs, or sharp edges that could damage the shaft seals during reassembly.

Note: Always use new seals when reassembling hydraulic motors. Refer to parts list 6-146 for seal kit part numbers, replacement parts, and ordering information.

Important: During reassembly lubricate the new seals with a petroleum jelly such as Vaseline®. Also lubricate machined surfaces and bearings with clean hydraulic fluid.

8 Remove all of the old Loctite® from the mounting flange cap screws and their threaded holes. The threads must be clean and dry for the new Loctite to hold properly.

9 Lubricate and install the output shaft, needle thrust bearing, and bearing race into the housing.

Important: Do not permit oil to get into the four threaded holes.

10 Lubricate the exclusion seal and press it into its seat in the mounting flange. Figure 5 shows the correct seal orientation.

T Series Geroler Motors

Reassembly

11 Lubricate and install the back-up ring and pressure seal. Use seal installation tool no. 600523 to press the pressure seal into place (see Figure 5).

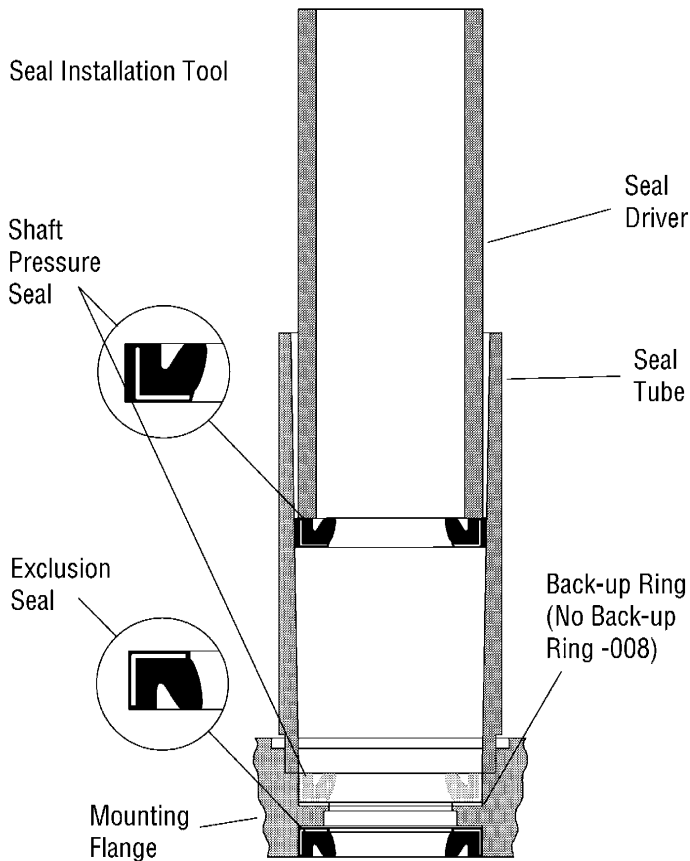

Figure 5

Important: Be sure the exclusion seal and pressure seal are undamaged and properly seated.

12 Apply three or four drops of Loctite 277 to the threads of the four holes in the motor housing where the mounting flange will be attached. Apply the Loctite so that it coats the threads. Remove all excess Loctite.

13 Install a protective sleeve or bullet over the output shaft. Lubricate the inner edges of the exclusion and pressure seals. Lubricate and install the 49 mm [1 15/16 in.] diameter o-ring seal on the mounting flange. Then slide the mounting flange down over the shaft.

14 Remove the protective sleeve and install the four cap screws. Tighten the cap screws, in a criss-cross pattern, to 28 Nm [250 lb-in]. Be sure the output shaft does not fall out of the housing.

Important: The Loctite must cure completely before the motor is put into service. Loctite curing time is six hours. Use of Loctite Primer reduces curing time to 15 minutes. Follow the instructions on the Loctite package.

15 Clamp the motor in the vise so the output shaft is vertical and down. Clamp on the mounting flange.

16 Pour clean hydraulic fluid into the motor to provide start-up lubrication.

17 Lubricate and install one of the three largest diameter seals in the groove in the motor housing.

18 Install the drive.

Note: If the splined ends of the drive are different lengths, install the longer end into the shaft.

Motor Timing

19 Align shaft timing dot with any bolt hole. Bolt hole will be used for timing reference.

20 Install spacer plate, and note the position of the threaded hole in housing aligned with the timing dot on shaft.

Important: Be sure the slots in the spacer plate provide passage for hydraulic fluid as well as the cap screws. If the spacer plate is flipped the motor will not operate.

21 Lightly stretch, lubricate and install the second of three large diameter seals in the groove in the Geroler.

22 Install the Geroler.

Standard Timing Align any star point with the threaded hole noted for the location of the timing dot (see Figure 6).

Reverse Timing Align any star valley with the threaded hole noted for the location of the timing dot (see Figure 6).

23 Rotate the geroler to align the screw holes and install drive spacer if applicable.

24 Lubricate and install the last one of the three large diameter seals in the groove in the end cap.

25 Install the end cap and seven cap screws.

26 Tighten the cap screws in a criss-cross pattern, to 27-28 Nm [235-250 lb-in].

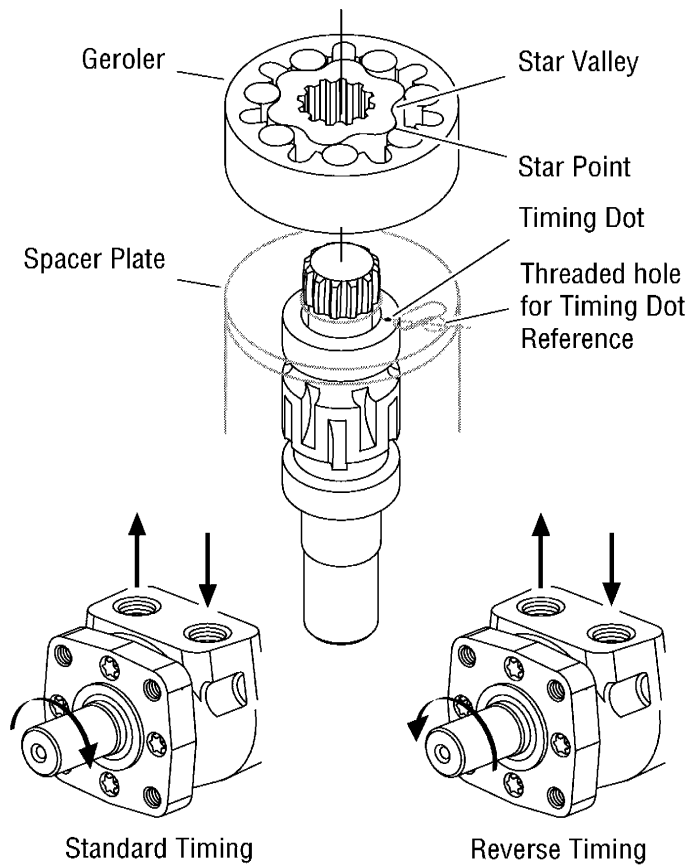
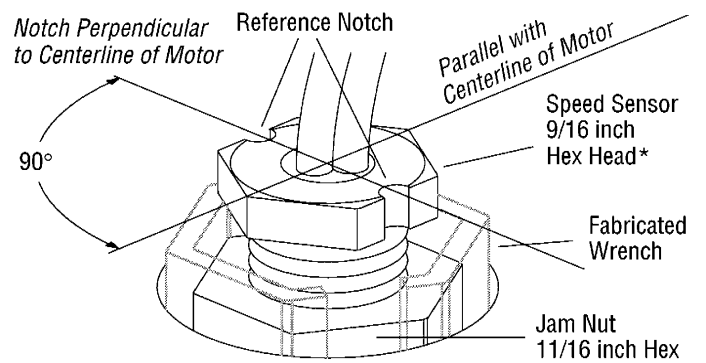

Figure 6

Speed Sensor Installation



*Turn Speed Sensor in to bottom (making sure jam nut is backed off sufficiently), back off 1/4 turn (CCW) and if reference notch(s) is not positioned as shown above continue turning (CCW) to align reference notch 90° off of centerline of motor or perpendicular to motor shaft. Hold speed sensor in this position and tighten jam nut to 8,5 — 14 Nm [75 — 125 lb-in].

General Purpose Motors

How to Order Replacement Parts

Each Order Must Include the Following:

1. Product Number
2. Date Code
3. Part Name
4. Part Number
5. Quantity of Parts

For More Detailed Information Contact Eaton Corp. Hydraulics Division 15151 Highway 5 Eden Prairie, MN 55344.

- Specifications and performance Data, Catalog No. 11-885
- Replacement Part Numbers and Kit Information — Parts Information No. 6-146

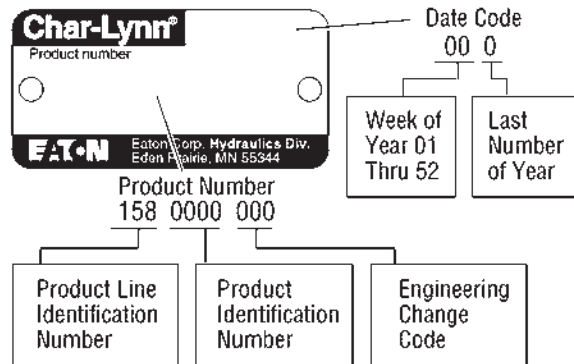

Product Numbers—T Series -001

Add three digit prefix —158—to four digit number from chart for complete product number—Example 158-1068.

Mounting	Shaft	Ports	Displ. cm ³ /r [in ³ /r] Product Number 158-xxxx											
			36 [2.2]	49 [3.0]	66 [4.0]	80 [4.9]	102 [6.2]	131 [8.0]	157 [9.6]	195 [11.9]	244 [14.9]	306 [18.7]	370 [22.6]	
2 Bolt Flange	1 in. Straight w/Woodruff Key	7/8-14 O-ring	158-	—	—	-1537	-1034	-1035	-1538	-1036	-1037	-1038	-1039	-1040
		1/2 NPTF	158-	—	—	-1540	-1026	-1027	-1541	-1028	-1029	-1030	-1031	-1032
		Manifold	158-	—	—	-1543	-1042	-1043	-1544	-1044	-1045	-1046	-1047	-1048
	1 in. SAE 6B Splined	7/8-14 O-ring	158-	—	—	-1552	-1082	-1083	-1553	-1084	-1085	-1086	-1087	-1088
		1/2 NPTF	158-	—	—	-1555	-1074	-1075	-1556	-1076	-1077	-1078	-1079	-1080
		Manifold	158-	—	—	-1558	-1090	-1091	-1559	-1092	-1093	-1094	-1095	-1096
4 Bolt Flange	1 in. Straight w/Woodruff Key	7/8-14 O-ring	158-	—	—	-1570	-1010	-1011	-1571	-1012	-1013	-1014	-1015	-1016
		1/2 NPTF	158-	—	—	-1573	-1002	-1003	-1574	-1004	-1005	-1006	-1007	-1008
		Manifold	158-	—	—	-1576	-1018	-1019	-1577	-1020	-1021	-1022	-1023	-1024
	1 in. SAE 6B Splined	7/8-14 O-ring	158-	—	—	-1579	-1058	-1059	-1580	-1060	-1061	-1062	-1063	-1064
		1/2 NPTF	158-	—	—	-1582	-1050	-1051	-1583	-1052	-1053	-1054	-1055	-1056
		Manifold	158-	—	—	-1585	-1066	-1067	-1586	-1068	-1069	-1070	-1071	-1072

158-1068

Eaton
Fluid Power Group
Hydraulics Business USA
14615 Lone Oak Road
Eden Prairie, MN 55344
USA
Tel: 952-937-9800
Fax: 952-294-7722
www.eaton.com/hydraulics

Eaton
Fluid Power Group
Hydraulics Business Europe
Route de la Longeraie 7
1110 Morges
Switzerland
Tel: +41 (0) 21 811 4600
Fax: +41 (0) 21 811 4601

Eaton
Fluid Power Group
Hydraulics Business Asia Pacific
11th Floor Hong Kong New World Tower
300 Huaihai Zhong Road
Shanghai 200021
China
Tel: 86-21-6387-9988
Fax: 86-21-6335-3912