

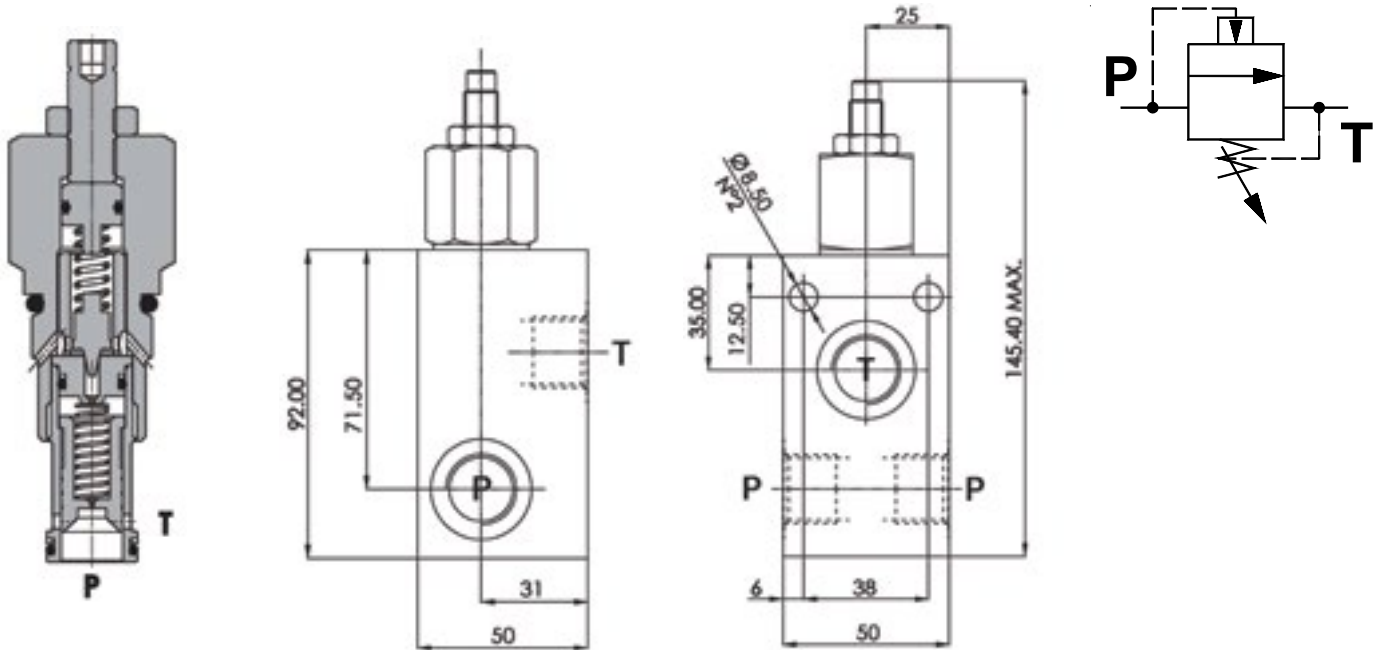

FLUID-PRESS

## RELIEF VALVES

Line Mounted, Pilot Operated, Sliding Spool Relief Valve  
FPM-P-150-CB-P-3/4-20



### Technical Specifications

<b>Materials</b>	Cartridge = steel, zinc plated Internal parts = hardened steel Body = high strength aluminium alloy
<b>Rated Flow</b>	150 LPM
<b>Adjustment Range</b>	15-250 bar
<b>Standard Setting</b>	15 bar
<b>Pressure Inc. Per Turn</b>	55 bar
<b>Max. Pressure</b>	210 bar
<b>Weight</b>	0.650 kg
<b>Installation Torque</b>	60 Nm
<b>Port Sizes</b>	G3/4
<b>Adjustment Type</b>	Leakproof screw
<b>Oil Temperature Range</b>	-20°C + 80°C
<b>Recommended Filtration</b>	Nominal max. 10µ, ISO 4406-19/17/14 (NAS8) or less
<b>Ambient Temperature Range</b>	-30°C + 60°C

### Pressure Drop Curves

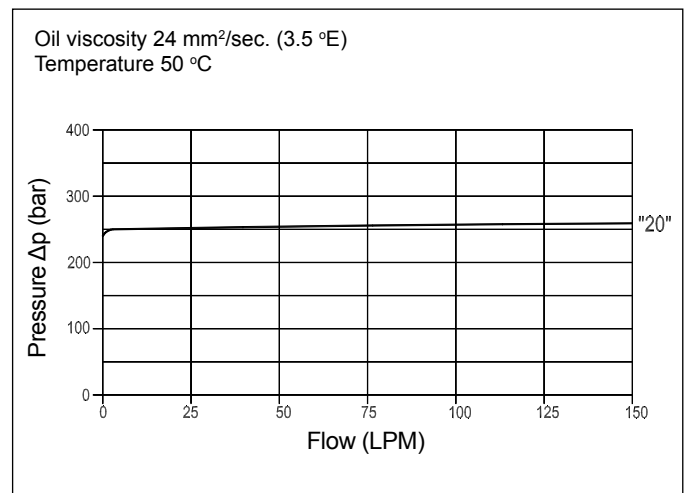

Content is subject to change without notice. Please refer to our website for the most current product information.