

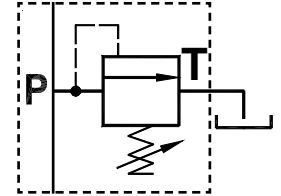

RELIEF VALVES

Line Mounted, Direct Acting, Guided Poppet Relief Valve
FPM-D-70-CB-P-3/4-20

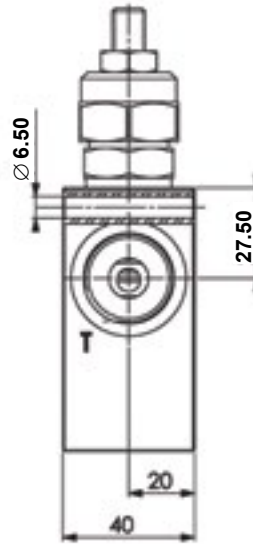
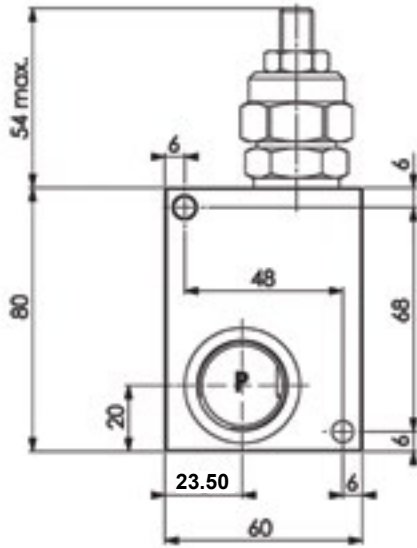

Technical Specifications

Materials	Cartridge = steel, zinc plated Internal parts = hardened steel Body = high strength alloy
Rated Flow	80 LPM
Adjustment Range	80 - 280 bar
Standard Setting	80 bar
Pressure Inc. Per Turn	40 bar
Max. Setting	280 bar
Cartridge with Body Weight	0.730 kg
Installation Torque	70-80 Nm
Port Sizes	PT = G3/4
Adjustment Type	Leakproof screw
Oil Temperature Range	-20°C + 80°C
Recommended Filtration	Nominal max. 10µ, ISO 4406-19/17/14 (NAS8) or less
Ambient Temperature Range	-30°C + 60°C

Pressure Drop Curves

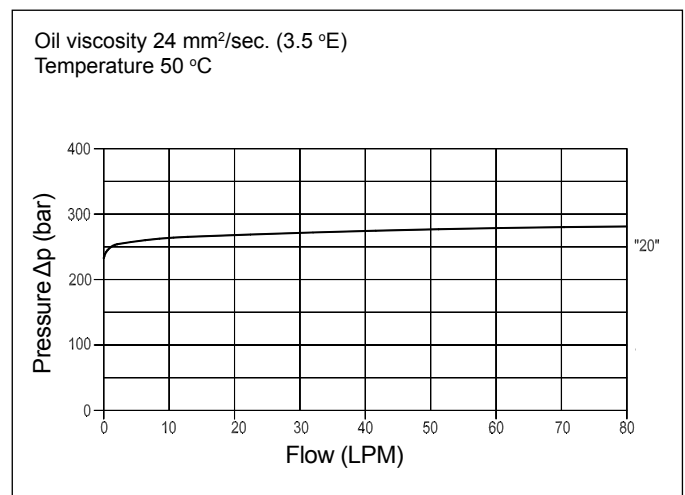

Content is subject to change without notice. Please refer to our website for the most current product information.