

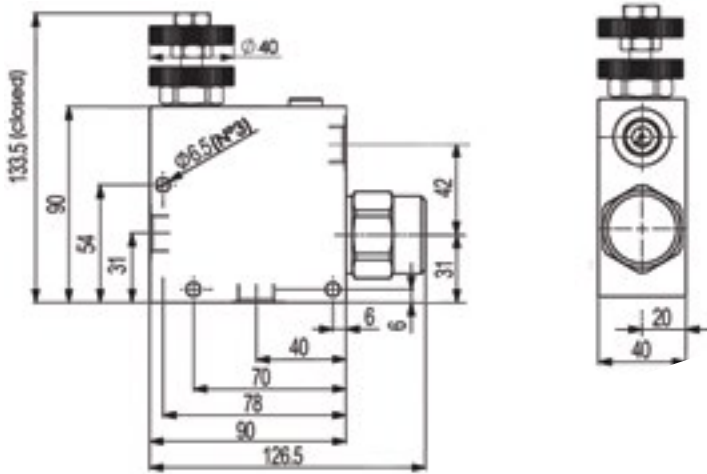

FLUID-PRESS

FLOW CONTROL VALVES

Line Mounted, 3 Way Pressure Compensated Flow Regulator
FPRF-1/2-G

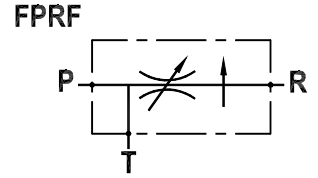
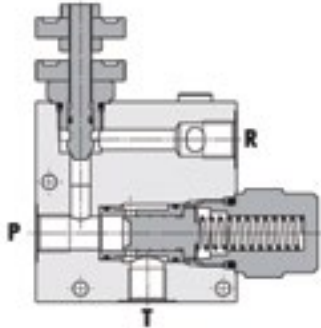

Technical Specifications

Materials	Body = aluminium Internal parts = hardened steel
Rated Flow	90 LPM with 50 LPM in "R" port
Standby Pressure	5 bar
Max. Pressure	210 bar
Weight	1.130 kg
Port Sizes	P/R/T = G1/2
Adjustment Type	Hand knob
Oil Temperature Range	-20°C + 80°C
Recommended Filtration	Nominal max. 10µ, ISO 4406-19/17/14 (NAS8) or less
Ambient Temperature Range	-30°C + 60°C

Compensation Curves

Oil viscosity 24 mm²/sec. (3.5 °E)
Temperature 50 °C

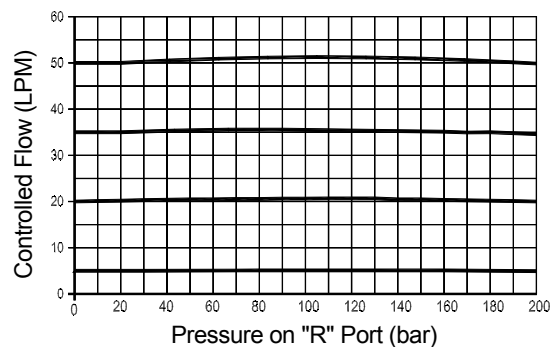

Content is subject to change without notice. Please refer to our website for the most current product information.