

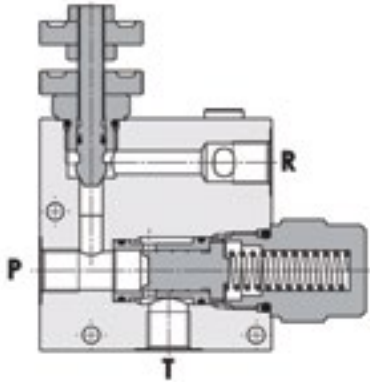

**FLUID-PRESS**

# FLOW CONTROL VALVES

Line Mounted, 3 Way Pressure Compensated Flow Regulator  
FPRF-3/8-G



**FPRF**

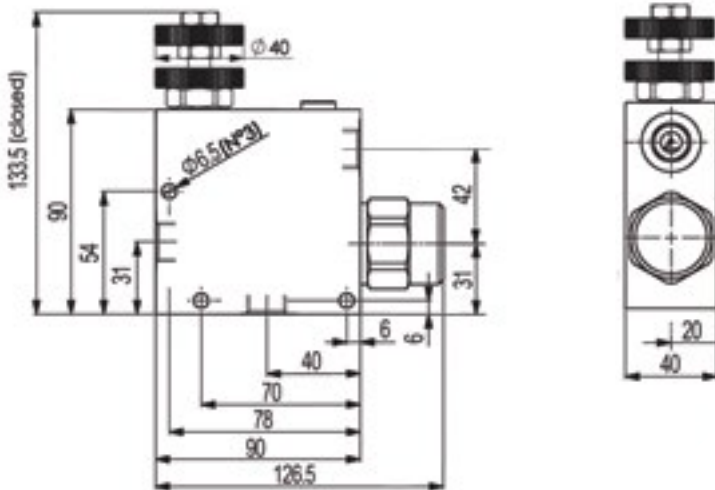
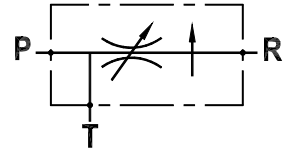

## Technical Specifications

<b>Materials</b>	Body = aluminium Internal parts = hardened steel
<b>Rated Flow</b>	50 LPM with 30 LPM in "R" port
<b>Standby Pressure</b>	5 bar
<b>Max. Pressure</b>	210 bar
<b>Weight</b>	1.155 kg
<b>Port Sizes</b>	P/R/T = G3/8
<b>Adjustment Type</b>	Hand knob
<b>Oil Temperature Range</b>	-20°C + 80°C
<b>Recommended Filtration</b>	Nominal max. 10µ, ISO 4406-19/17/14 (NAS8) or less
<b>Ambient Temperature Range</b>	-30°C + 60°C

## Compensation Curves

Oil viscosity 24 mm<sup>2</sup>/sec. (3.5 °E)  
Temperature 50 °C

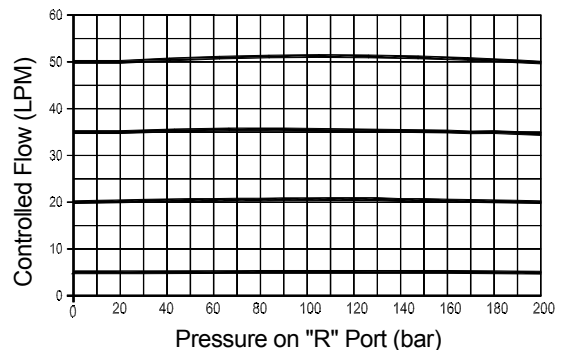

*Content is subject to change without notice. Please refer to our website for the most current product information.*