

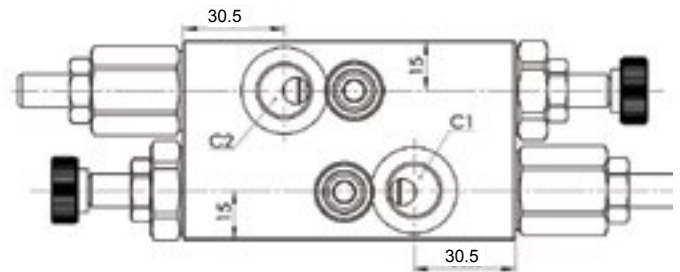

# OVER CENTRE VALVES

Line Mounted, Dual Over Centre Valve with Manual Override  
FP-1 11-0008

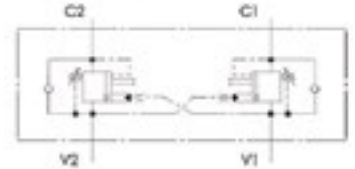
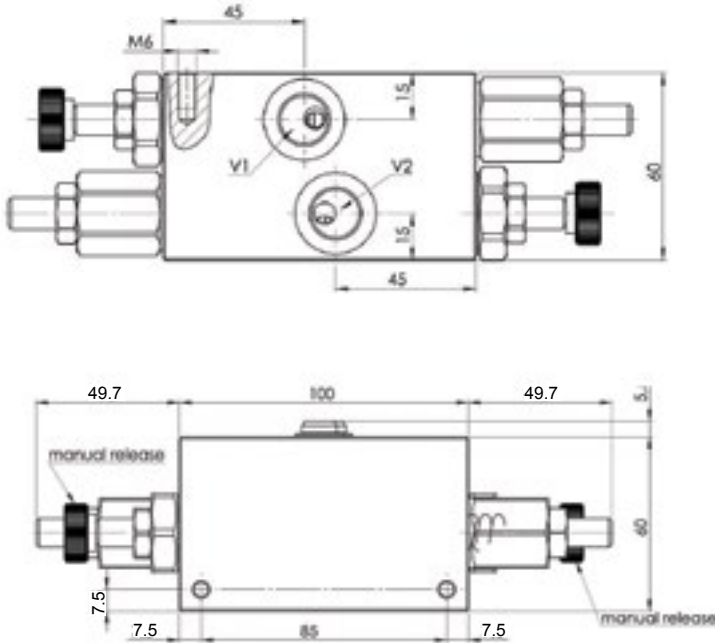

## Technical Specifications

<b>Materials</b>	Body = aluminium Internal parts = steel
<b>Max. Flow</b>	40 LPM
<b>Adjustment Range</b>	100 - 350 bar
<b>Standard Setting</b>	350 bar
<b>Pressure Inc. Per Turn</b>	120 bar
<b>Max. Setting</b>	210 bar
<b>Weight</b>	1.45 kg
<b>Pilot Ratio</b>	4.5:1
<b>Port Sizes</b>	C1/C2/V1/V2 = G3/8
<b>Adjustment Type</b>	Leakproof screw
<b>Oil Temperature Range</b>	-20°C + 80°C
<b>Recommended Filtration</b>	Nominal max. 10µ, ISO 4406-19/17/14 (NAS8) or less
<b>Ambient Temperature Range</b>	-30°C + 60°C

## Pressure Drop Curves

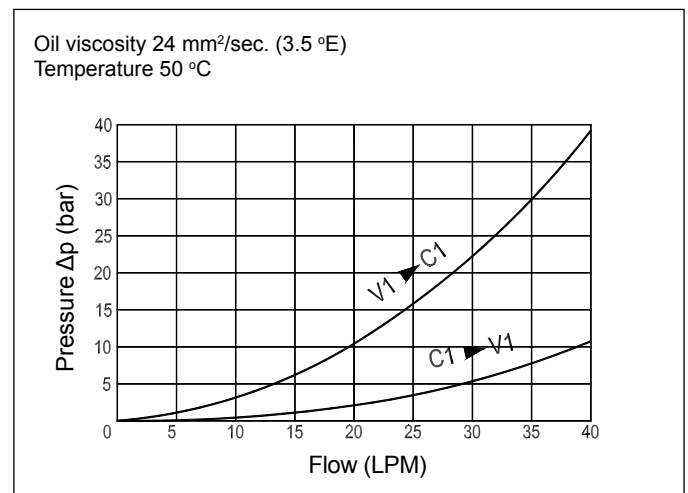

Content is subject to change without notice. Please refer to our website for the most current product information.