

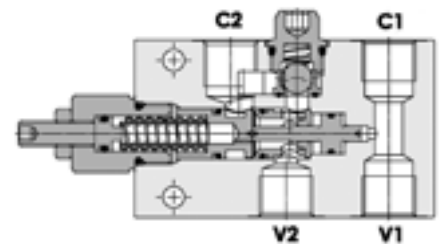

FLUID-PRESS

OVER CENTRE VALVES

Line Mounted, Single Over Centre Valve, Internal Pilot - E Series
FPOE-70-S-1/2-LPA-35

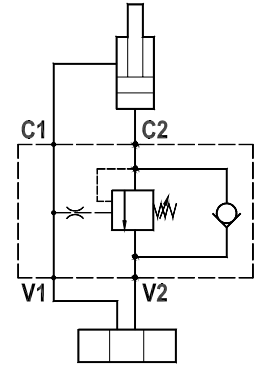
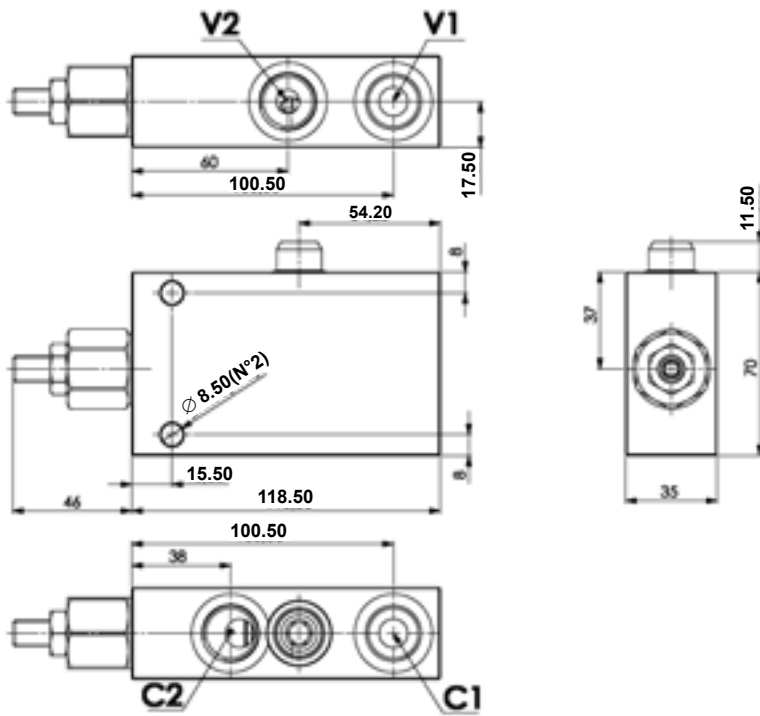

Technical Specifications

Materials	Body = aluminium alloy Internal parts = hardened steel
Rated Flow	up to 70 LPM
Adjustment Range	120-350 bar
Standard Setting	350 bar
Pressure Inc. Per Turn	90 bar
Max. Pressure	210 bar
Pilot Ratio	3.2:1
Weight	0.700 kg
Port Sizes	G1/2
Adjustment Type	Leakproof screw
Oil Temperature Range	-20°C + 80°C
Recommended Filtration	Nominal max. 10µ, ISO 4406-19/17/14 (NAS8) or less
Ambient Temperature Range	-30°C + 60°C

Pressure Drop Curves

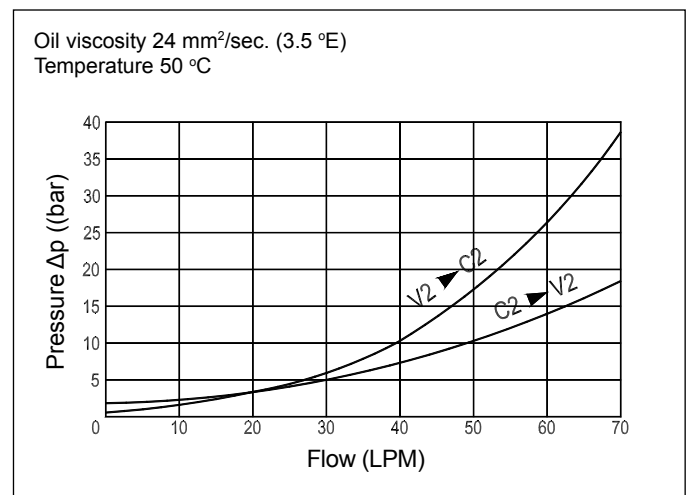

Content is subject to change without notice. Please refer to our website for the most current product information.