

# 75627 SAE "C" TO SAE "C"

## WET

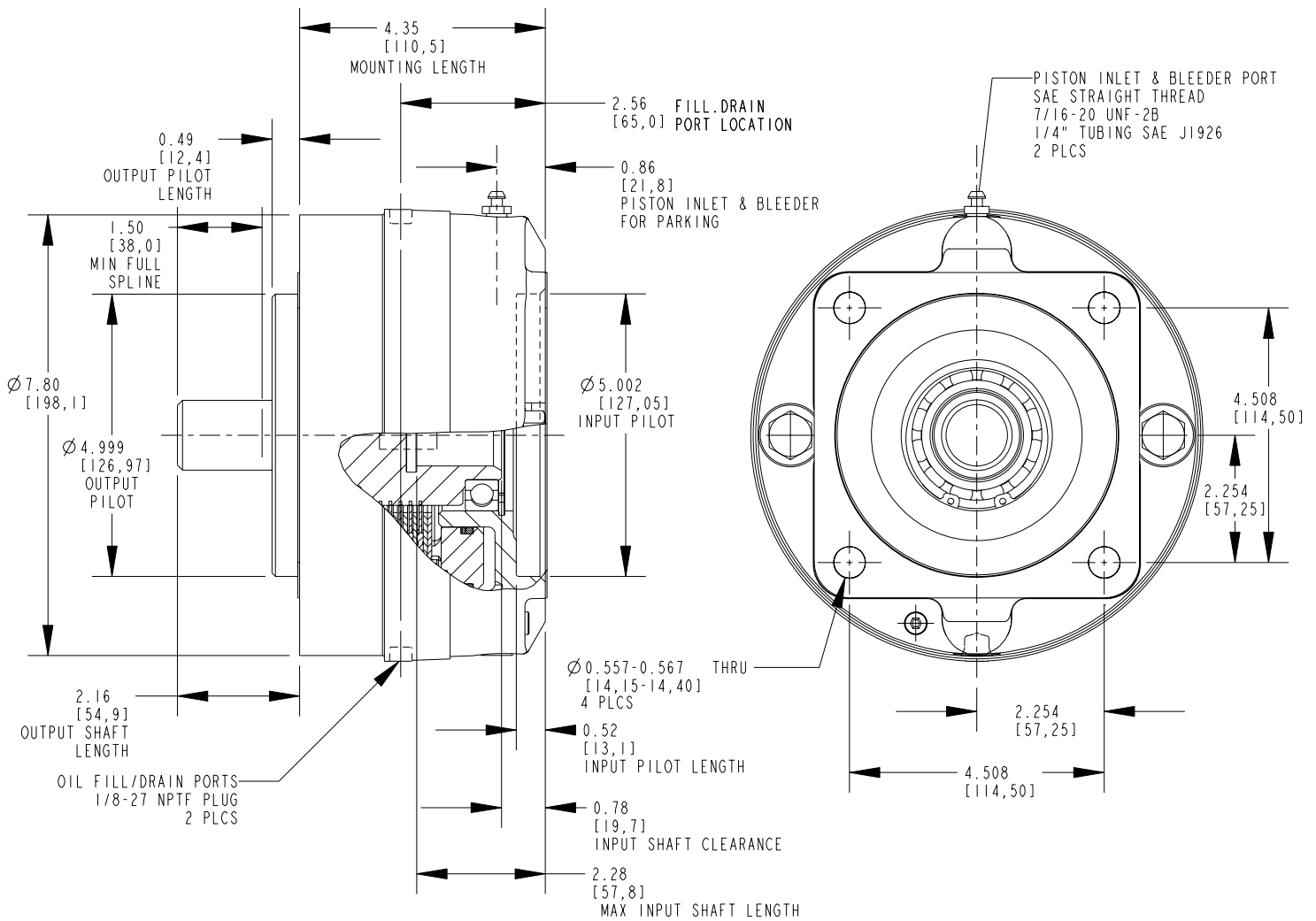

RATED TORQUE	5400 (610)
FULL RELEASE PRESSURE	150 (10)
INPUT SPLINE (INTERNAL)	14T 12/24 ANSI B92.1 SIDE FIT 30° PRESSURE ANGLE
OUTPUT SPLINE (EXTERNAL)	14T 12/24 ANSI B92.1 SIDE FIT 30° PRESSURE ANGLE
OIL FILL VOLUME HORIZONTAL (mL)	150
OIL FILL VOLUME VERTICAL (mL)	300
O-RING SERVICE KIT	PK-1368
STACK SERVICE KIT	PK-1370
BEARING SERVICE KIT	PK-933
GASKET SERVICE KIT	PK-679

- \* UNITS: LENGTH, DIAMETER = IN (mm), PRESSURE = PSI (BAR), TORQUE = LBS IN (Nm)
- \* MAX OPERATING PRESSURE FOR PARKING IS 3000 PSI (207 BAR).
- \* PRESSURE SPIKES OR SURGES ARE NOT TO EXCEED 4000 PSI (276 BAR).
- \* BRAKE CAVITY COOLING OIL PRESSURE NOT TO EXCEED 15 PSI (1 BAR).
- \* MAXIMUM HORIZONTAL OPERATING SPEED IS 5000 RPM.
- \* FOR VERTICAL APPLICATION, CONTACT AUSCO FOR MAX SPEED DETAILS.
- \* REVIEW IMPORTANT NOTES ON GENERAL INFORMATION.