

THE MULTI-DISC BRAKE IS A SPRING-APPLIED, HYDRAULICALLY RELEASED BRAKE. HYDRAULIC PRESSURE IS REQUIRED TO RELEASE OR "HOLD OFF" THE BRAKE. NORMAL OPERATION IS TO HAVE THE BRAKE PRESSURIZED IN THE RELEASED POSITION WITH THE VEHICLE HYDRAULIC SYSTEM RUNNING. ANY FUNCTION WHICH REDUCES THE HYDRAULIC SYSTEM BELOW THE RELEASE PRESSURE OF THE BRAKE WILL CAUSE THE BRAKE TO BE APPLIED.

CAUTION:

FOR CORRECT OPERATION, HYDRAULIC PRESSURE TO THE BRAKE MUST FALL TO ZERO PSI. ANY RESIDUAL BACK PRESSURE APPLIED TO THE BRAKE WILL DEGRADE FUNCTION AND MAY RESULT IN A HAZARDOUS CONDITION.

INSTALLATION INFORMATION:

1. ASSEMBLE BRAKE BETWEEN MOTOR AND GEARBOX. PLACE MOUNTING GASKETS ON THE MOUNTING FACES BEFORE ASSEMBLY. IF NEEDED, BRAKE SHAFT CAN BE ROTATED BY APPLYING HYDRAULIC PRESSURE TO THE PISTON INLET PORT.
2. INSERT TWO 1/2" DIA. BOLTS (GRADE 58) THROUGH THE MOTOR FLANGE, THE GASKET, THE BRAKE, AND INTO THE THREADED HOLES IN THE GEAR REDUCER. MAKE SURE THAT THE BOLTS ARE NOT TOO LONG, SO THEY DO NOT BOTTOM OUT IN THE THREADED HOLES OF THE GEAR REDUCER.
3. TO PREVENT BINDING, RUN THE BOLTS IN ALTERNATELY UNTIL SNUG. TORQUE BOLTS TO 80-90 FT.-LBS.
NOTE: THE SHAFTS MUST SLIDE TOGETHER FREELY. DO NOT USE THE BOLTS TO FORCE THEM TOGETHER.
4. WITH MOTOR AND BRAKE BOLTED TOGETHER INTO POSITION, CONNECT INLET HYDRAULIC LINE. BRAKE INLET IS 1/4" LINE STRAIGHT THREAD O-RING BOSS (7/16-20 UNF).

BRAKE DISASSEMBLY INFORMATION:

1. DISASSEMBLE IN THE FOLLOWING ORDER: BOLTS (ALTERNATELY), POWER PLATE, GASKET, STATIONARY DISCS, ROTATING DISCS, PRIMARY DISC, TORQUE PINS, COMPRESSION SPRINGS, AND SPRING RETAINER.
2. FURTHER DISASSEMBLY IS NOT RECOMMENDED AND SHOULD NOT BE ATTEMPTED UNLESS NECESSARY TO REPLACE THE BEARING, THE SEAL, OR THE SHAFT.
NOTE: IF THE BEARING AND SEAL ARE REMOVED FOR ANY REASON, BOTH MUST BE REPLACED.
 - 2a. REMOVE SNAP RINGS AS NEEDED.
 - 2b. SEAL CAN BE REMOVED BY PRYING IT OUT WITH AN APPROPRIATE TOOL. TAKE CARE NOT TO DAMAGE THE BORE.
 - 2c. SHAFT CAN BE REMOVED BY PRESSING IT OUT WITH A SHOP PRESS.
3. REMOVE THE PISTON FROM THE POWER PLATE BY INTRODUCING LOW PRESSURE AIR (15 psi) INTO THE HYDRAULIC INLET. MAKE SURE THE PISTON IS DIRECTED AWAY FROM THE OPERATOR. DO NOT REMOVE O-RINGS AND BACKUP RINGS FROM THE O.D. AND I.D. GROOVES OF THE PISTON UNLESS REPLACEMENT IS NECESSARY, BECAUSE THEY WILL BE DAMAGED.

ASSEMBLY INFORMATION:

IMPORTANT: THERE MAY BE MORE PARTS IN A SERVICE KIT THAN YOUR BRAKE REQUIRES. CHECK THE PARTS LIST CAREFULLY FOR THE EXACT QUANTITY. SPACE THE SPRINGS AS SHOWN ON THE SPRING ORIENTATION VIEW.

USE THE REVERSE OF THE DISASSEMBLY PROCEDURE WITH THE FOLLOWING NOTES AND ADDITIONS:

1. WORN AND DAMAGED O-RINGS AND BACKUP RINGS MUST BE REPLACED PRIOR TO RE-ASSEMBLY.
2. LUBRICATE THE PISTON BORE OF THE POWER PLATE, THE PISTON, AND THE O-RINGS WITH SYSTEM HYDRAULIC FLUID PRIOR TO RE-ASSEMBLY.
3. PISTON ASSEMBLY:
ASSEMBLE PISTON INTO POWER PLATE USING A SHOP PRESS. TAKE CARE NOT TO DAMAGE THE O-RING OR TEFLON BACKUP RINGS. VISUALLY ALIGN THE CENTER OF THE CUTOUTS IN THE PISTON WITH THE TORQUE PIN HOLES IN THE POWER PLATE.
CAUTION: THE DEPTH THE PISTON IS INSTALLED INTO THE POWER PLATE IS CRITICAL. THE SURFACE OF THE PISTON AT THE CUTOUTS MUST BE FLUSH TO 0.120 BELOW THE SURFACE OF THE POWER PLATE, OR PISTON MAY COCK RESULTING IN A COMPLETE LOSS OF BRAKING.
4. BEARING ASSEMBLY:
USE A SHOP PRESS TO PRESS THE BEARING ONTO THE SHAFT. PRESS ONLY ON THE INNER RACE OF THE BEARING. BEARING IS A SLIP FIT TO THE HOUSING.
5. LIP SEAL ASSEMBLY:
LIP OF SEAL MUST FACE AWAY THE BEARING. SEE CUTAWAY VIEW FOR SEAL ORIENTATION DETAIL.
6. ROTATING, STATIONARY, AND PRIMARY DISC ASSEMBLY:
ROTATING DISCS MUST BE CLEAN & DRY. THE LINING MATERIAL AND MATING SURFACES OF THE STATIONARY DISCS MUST BE THOROUGHLY CLEAN AND FREE FROM DEBRIS. WORN OR SCARRED ROTATING DISCS MUST BE REPLACED.
7. INSTALL BOLTS IN THE POWER PLATE. TIGHTEN SEQUENTIALLY ONE TURN AT A TIME UNTIL POWER PLATE IS PROPERLY SEATED. TORQUE BOLTS TO 80-90 FT-LBS.

OIL FILL PROCEDURE:

UNSCREW THE TOP OIL FILL PLUG AND ADD DTE-26 OIL TO THE APPROPRIATE LEVEL.

SERVICE KIT INFORMATION:

- BEARING KIT: PK - 1320 - INCLUDES SEALS, RETAINING RINGS, AND BEARINGS.
- STACK KIT: PK - 1323 - INCLUDES TORQUE PINS, PRIMARY, STATIONARY, ROTATING DISCS AND COMPRESSION SPRINGS.
- O-RING KIT: PK- 1324 - INCLUDES O-RINGS, BACKUP RINGS, AND INTERNAL GASKET.
- GASKET KIT: PK - 1325 - INCLUDES EXTERIOR GASKET(S).



BRAKE NUMBER 75255 PARTS LIST

ECO 24393 REV H

	PART	DESCRIPTION	QTY
1	28426	GASKET	2
2	75395	PIPE PLUG	2
3	75503	HOUSING	1
4	35875	TORQUE PIN	2
5	28963	COMPRESSION SPRING	10
6	74554	SPRING RETAINER	1
7	28962	COMPRESSION SPRING	10
8	75124	SHAFT	1
9	34574	BEARING	1
10	75540	SNAP RING	1
11	37144	SEAL	1
12	74553	PRIMARY DISC	1
13	74551	ROTATING DISC	4
14	74552	STATIONARY DISC	4
15	73741	GASKET	1
16	27966	BACKUP RING	1
17	27777	O-RING	1
18	27808	O-RING	1
19	27967	BACKUP RING	1
20	75499	POWER PLATE	1
21	75109	PISTON	1
22	29035	BLEEDER	1
23	73594	HEX HEAD BOLT	4
24	74877	WASHER	4
25	28435	PROTECTIVE PLUG	1
26	75970	CAUTION TAG	1

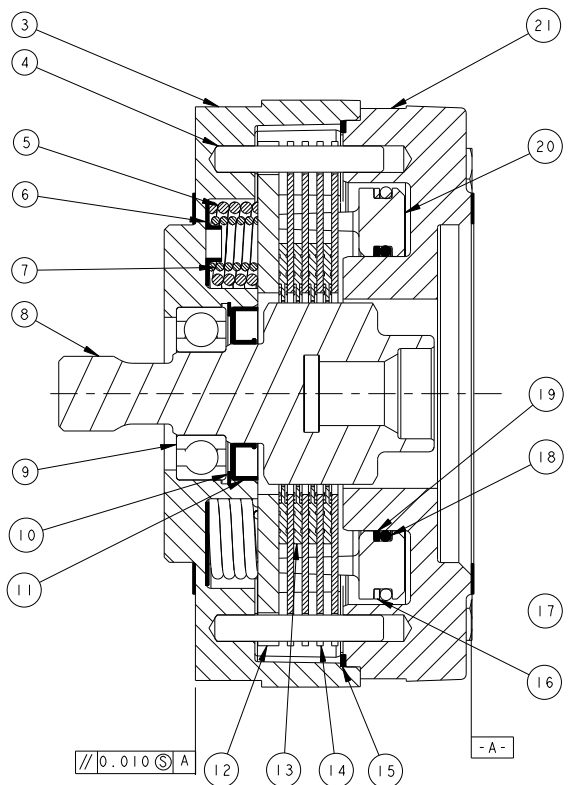
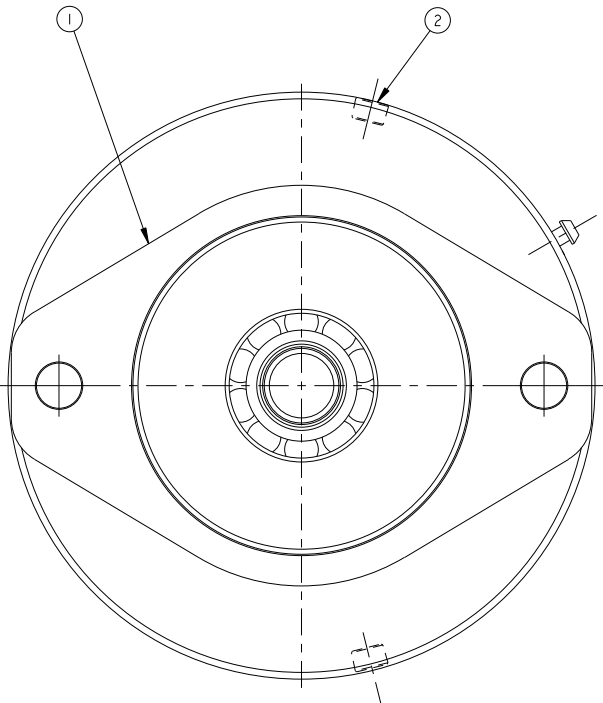

SECTION A-A

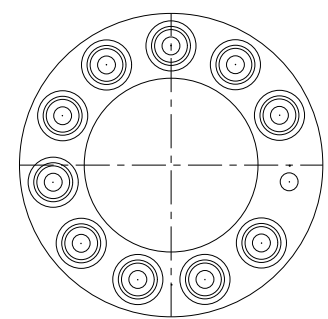
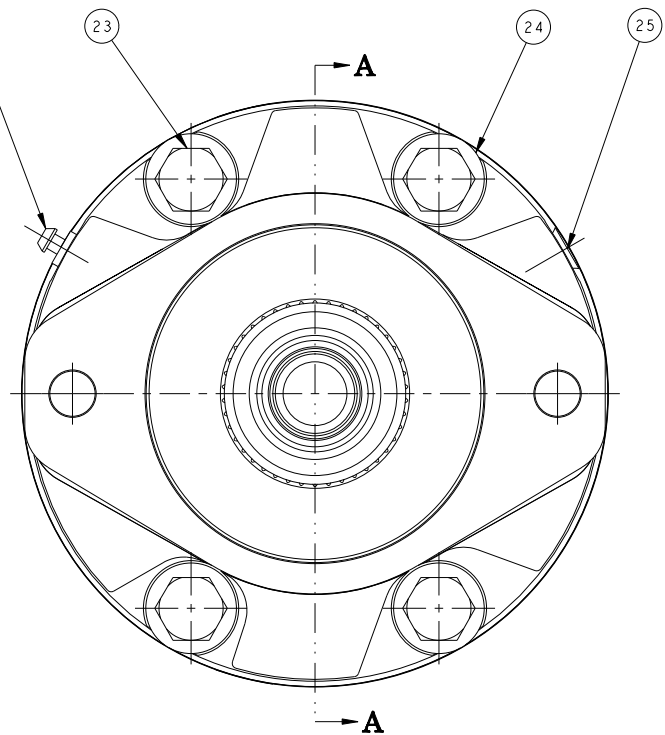

NESTED SPRING ORIENTATION
NO SCALE



STANDARD WET OR DRY MULTI-DISC BRAKES GENERAL ASSEMBLY VIEW

NOTE: THIS DRAWING PROVIDES GENERAL GUIDELINES AND ASSEMBLY INFORMATION ON AUSCO MULTI-DISC BRAKES. CONFIGURATION OF BRAKES VARIES FROM MODEL TO MODEL. CONSULT YOUR BRAKES SERVICE NOTES, BILL OF MATERIAL, AND CUTAWAY VIEW FOR EXACT DETAILS.

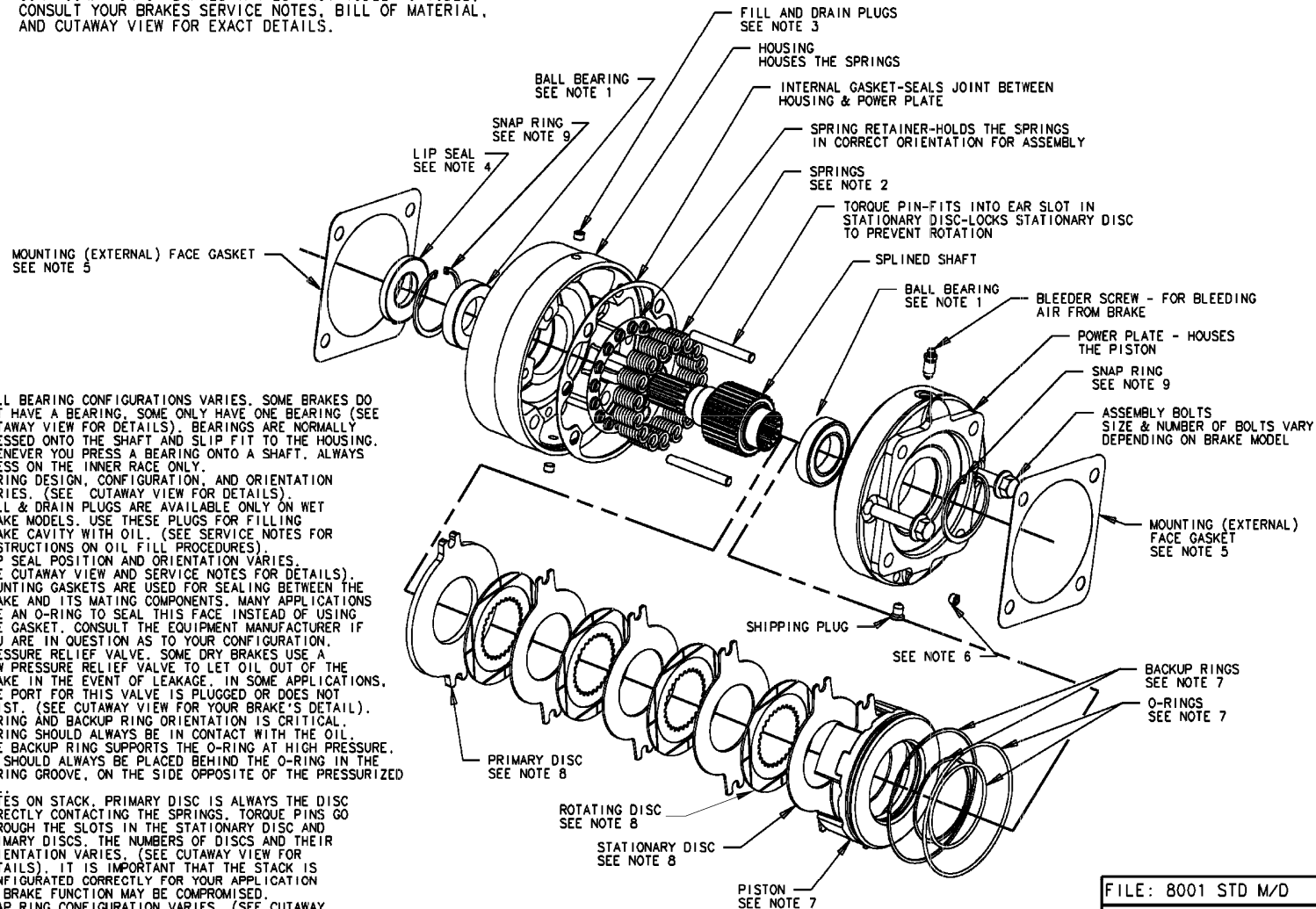

NOTES:

1. BALL BEARING CONFIGURATIONS VARIES. SOME BRAKES DO NOT HAVE A BEARING. SOME ONLY HAVE ONE BEARING (SEE CUTAWAY VIEW FOR DETAILS). BEARINGS ARE NORMALLY PRESSED ONTO THE SHAFT AND SLIP FIT TO THE HOUSING. WHENEVER YOU PRESS A BEARING ONTO A SHAFT. ALWAYS PRESS ON THE INNER RACE ONLY.
2. SPRING DESIGN, CONFIGURATION, AND ORIENTATION VARIES. (SEE CUTAWAY VIEW FOR DETAILS).
3. FILL & DRAIN PLUGS ARE AVAILABLE ONLY ON WET BRAKE MODELS. USE THESE PLUGS FOR FILLING BRAKE CAVITY WITH OIL. (SEE SERVICE NOTES FOR INSTRUCTIONS ON OIL FILL PROCEDURES).
4. LIP SEAL POSITION AND ORIENTATION VARIES. (SEE CUTAWAY VIEW AND SERVICE NOTES FOR DETAILS).
5. MOUNTING GASKETS ARE USED FOR SEALING BETWEEN THE BRAKE AND ITS MATING COMPONENTS. MANY APPLICATIONS USE AN O-RING TO SEAL THIS FACE INSTEAD OF USING THE GASKET. CONSULT THE EQUIPMENT MANUFACTURER IF YOU ARE IN QUESTION AS TO YOUR CONFIGURATION.
6. PRESSURE RELIEF VALVE. SOME DRY BRAKES USE A LOW PRESSURE RELIEF VALVE TO LET OIL OUT OF THE BRAKE IN THE EVENT OF LEAKAGE. IN SOME APPLICATIONS, THE PORT FOR THIS VALVE IS PLUGGED OR DOES NOT EXIST. (SEE CUTAWAY VIEW FOR YOUR BRAKE'S DETAIL).
7. O-RING AND BACKUP RING ORIENTATION IS CRITICAL. O-RING SHOULD ALWAYS BE IN CONTACT WITH THE OIL. THE BACKUP RING SUPPORTS THE O-RING AT HIGH PRESSURE. IT SHOULD ALWAYS BE PLACED BEHIND THE O-RING IN THE O-RING GROOVE, ON THE SIDE OPPOSITE OF THE PRESSURIZED OIL.
8. NOTES ON STACK, PRIMARY DISC IS ALWAYS THE DISC DIRECTLY CONTACTING THE SPRINGS. TORQUE PINS GO THROUGH THE SLOTS IN THE STATIONARY DISC AND PRIMARY DISCS. THE NUMBERS OF DISCS AND THEIR ORIENTATION VARIES. (SEE CUTAWAY VIEW FOR DETAILS). IT IS IMPORTANT THAT THE STACK IS CONFIGURATED CORRECTLY FOR YOUR APPLICATION OR BRAKE FUNCTION MAY BE COMPROMISED.
9. SNAP RING CONFIGURATION VARIES. (SEE CUTAWAY VIEW FOR DETAILS).

FILE: 8001 STD M/D
CURRENT REV: ECO11481 REV A