

75125 MODIFIED SAE "A" TO SAE "B" WET

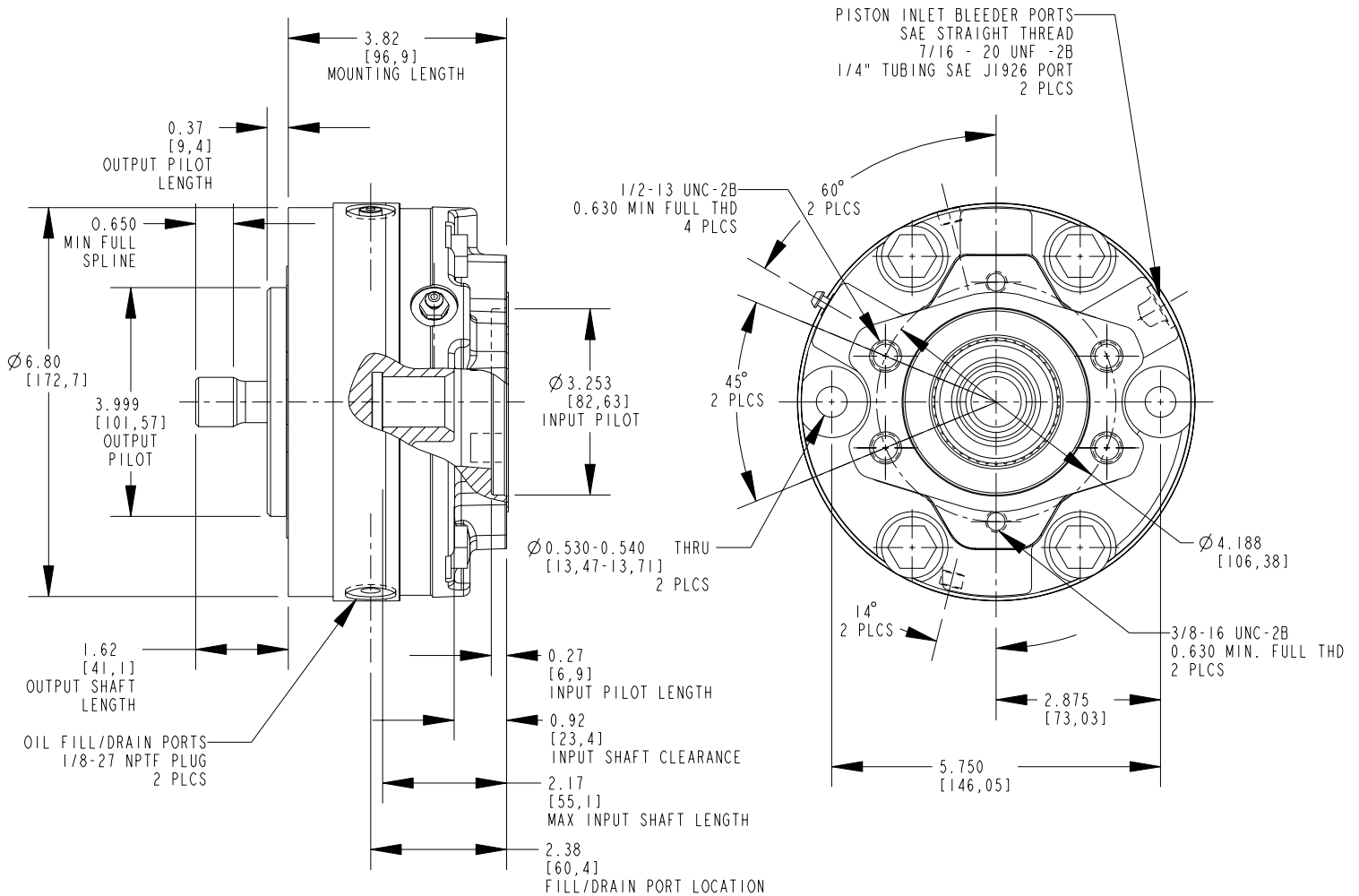

RATED TORQUE	3800 (429)
FULL RELEASE PRESSURE	240 (17)
INPUT SPLINE (INTERNAL)	SAE 6B 1.00 O.D. PARALLEL SIDE FIT
OUTPUT SPLINE (EXTERNAL)	13T 16/32 ANSI B92.1 SIDE FIT 30° PRESSURE ANGLE
OIL FILL VOLUME HORIZONTAL (mL)	160
OIL FILL VOLUME VERTICAL (mL)	320
O-RING SERVICE KIT	PK-1324
STACK SERVICE KIT	PK-1323
BEARING SERVICE KIT	PK-1320
GASKET SERVICE KIT	PK-1356

- * UNITS: LENGTH, DIAMETER = IN (mm), PRESSURE = PSI (BAR), TORQUE = LBS IN (Nm)
- * MAX OPERATING PRESSURE FOR PARKING IS 3000 PSI (207 BAR).
- * PRESSURE SPIKES OR SURGES ARE NOT TO EXCEED 4000 PSI (276 BAR).
- * BRAKE CAVITY COOLING OIL PRESSURE NOT TO EXCEED 15 PSI (1 BAR).
- * MAXIMUM HORIZONTAL OPERATING SPEED IS 5000 RPM.
- * FOR VERTICAL APPLICATION, CONTACT AUSCO FOR MAX SPEED DETAILS.
- * REVIEW IMPORTANT NOTES ON GENERAL INFORMATION.