

## Variable Displacement Piston Pump

### Manual Controlled



Model 70160  
20,3 cm<sup>3</sup>/r [1.24 in<sup>3</sup>/r]  
23,6 cm<sup>3</sup>/r [1.44 in<sup>3</sup>/r]



Model 70360  
40,6 cm<sup>3</sup>/r [2.48 in<sup>3</sup>/r]  
49,2 cm<sup>3</sup>/r [3.00 in<sup>3</sup>/r]

### Servo Controlled

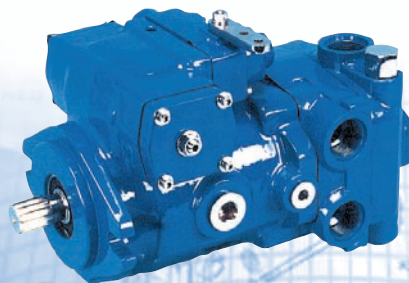

Model 72400  
40,6 cm<sup>3</sup>/r [2.48 in<sup>3</sup>/r]  
49,2 cm<sup>3</sup>/r [3.00 in<sup>3</sup>/r]

We Manufacture

# Solutions

Hydraulics

---

Experienced system design engineers - Systems-based solutions to all your hydraulic needs.

Global manufacturing capability - Manufacturing plants and joint ventures in the U.S., Europe, Japan and China.

Global sales support - Sales offices in the U.S., Scotland, Germany, Singapore, China and Korea.

World's largest distributor network - Over 100 distributors in 50 different countries.

Reliable, robust products - Field-proven leader in the hydraulics industry.

Exceptional product quality - All products manufactured in ISO 9001-certified sites.

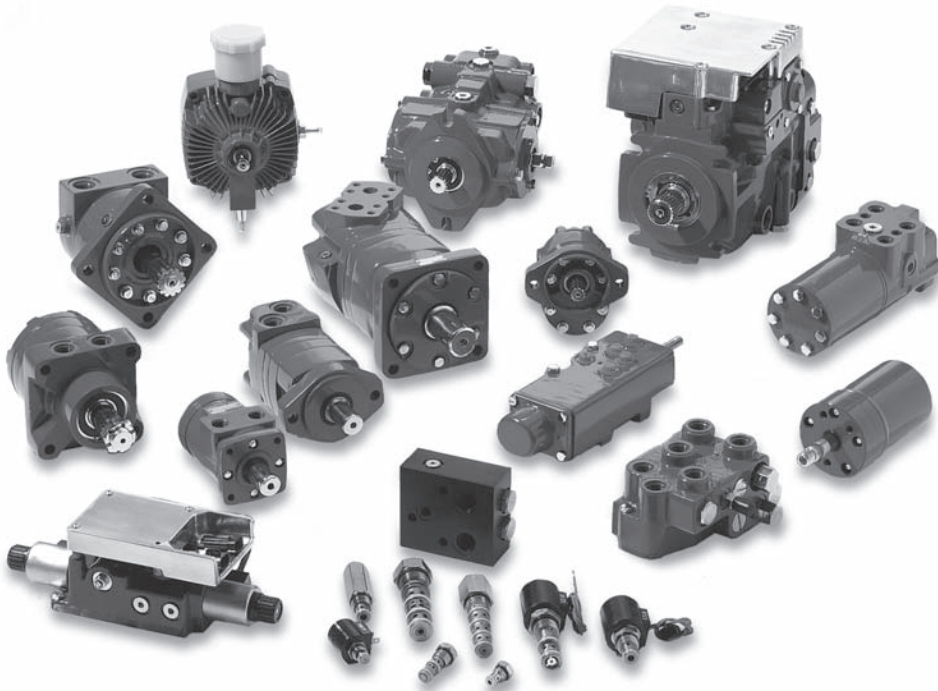

Hydraulics Division



# Contents

- Introduction ..... 4
- Typical Applications ..... 4
- Model 70160 - Section 1 ..... 5**
  - Features ..... 6-7
  - Installation Drawings ..... 8-9
  - Specifications ..... 10
  - Performance Data ..... 11
  - Model 70160 Code ..... 12-13
  - Input Shafts ..... 14
  - Auxiliary Rear Mounts & Output Shafts ..... 15
  - Bracket and Cover Plate ..... 16
  - Port locations ..... 17
  - 70160 and 70142 Comparisons, Key Improvements 18 - 19
- Model 70360 - Section 2 ..... 21**
  - Features ..... 22-23
  - Installation Drawings, Typical ..... 24
  - Installation Drawings, Tandem Assembly ..... 25
  - Specifications ..... 26
  - Performance Data ..... 27
  - Model 70360 Code ..... 28-29
  - Input Shafts ..... 30
  - Auxiliary Rear Mounts & Output Shafts ..... 31
  - Port locations ..... 32-33
- Model 72400 - Section 3 ..... 35**
  - Features ..... 36-37
  - Installation Drawing - Single Piston Pump ..... 38-39
  - Installation Drawing -
    - Front Piston Pump of Tandem Pumps ..... 40-41
  - Installation Drawing -
    - Rear Piston Pump of Tandem Pumps ..... 42-43
  - Features, Benefits & Specifications ..... 44
  - Performance Data ..... 45
  - Model 72400 Code ..... 46-47
  - Input Shafts ..... 48
  - Output Shafts ..... 49
  - Auxiliary Rear Mounts ..... 50
  - Charge Pump Routing and Location ..... 51
  - Auxiliary and Drain Port Locations ..... 52
  - Main Ports and Relief Valve Location ..... 53
  - Additional Functions ..... 54
  - Control Assembly -
    - Port Plate ..... 54
    - Manual Control ..... 55
    - Hydraulic Remote Control ..... 56
    - Electronic Proportional Displ. Control ..... 57-59
    - Solenoid Operated Control ..... 60
    - Adjustable displacement Limiter ..... 61-62
  - 72400 Supply and Control Orifice ..... 63

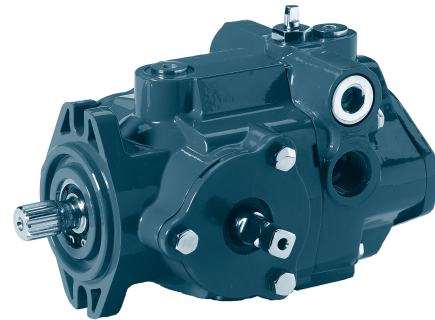

Model 70160

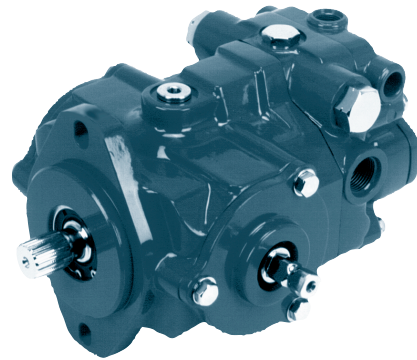

Model 70360

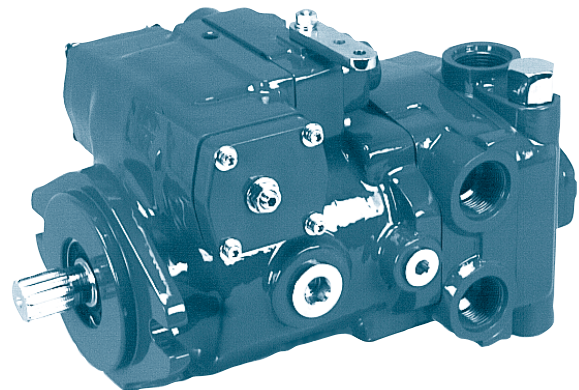

Model 72400

- Application Information - Section 4 ..... 64**
  - Component Selection ..... 64-65
  - Installation Requirements ..... 65
  - Hydraulic Fluid Recommendations ..... 66-67

Application Info.

# Introduction

Variable displacement piston pumps are used in closed loop systems either as a single or tandem pump. Oil is circulated by the pump to the motor and then returned directly back to the pump. A charge supply is used to supplement the closed loop system with oil. The charge supply may be supplied by an internal charge pump (standard) or an external source.

## Typical Applications

### Harvester Equipment

- Combines
- Fruit or Vegetable Pickers
- Swathers



### Forestry Equipment

- Log Skidders
- Bark Removers
- Limb Removers

### Construction Equipment

- Trenchers
- Skid Loaders
- Utility Vehicles
- Sweepers



### Turf Care Equipment

- Mowers
- Loaders



### Industrial Equipment

- Lift Trucks
- Sissor lifts



### Paving Equipment

- Rollers
- Packers



## Section 3

## Model 72400

### Servo Controlled

40,6 cm<sup>3</sup>/r [2.48 in<sup>3</sup>/r]

49,2 cm<sup>3</sup>/r [3.00 in<sup>3</sup>/r]

Displacement

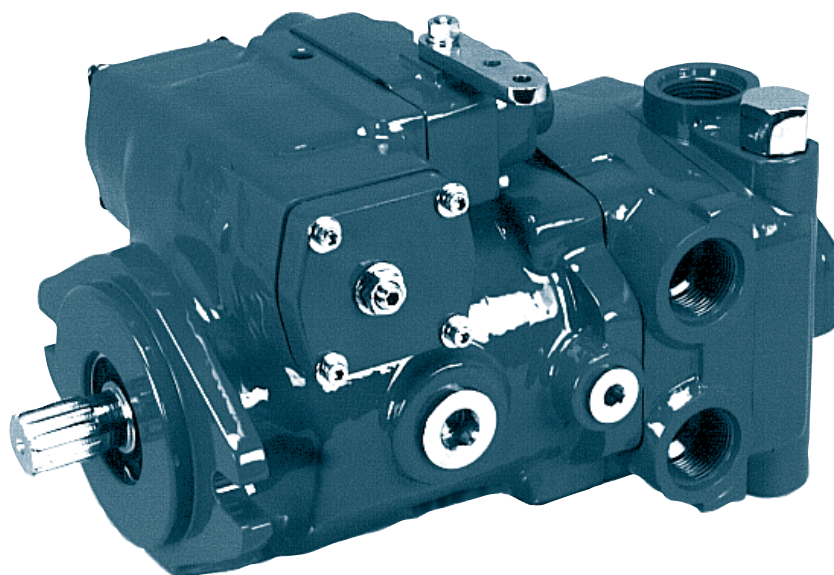

Model 72400

# Features

## Model 72400

### A. Housing

- Compact package size.
- Durable cast iron design.
- Multiple drain options.
- Quiet operation.

### B. Endcover

### C. Charge Pump Adapter

### D. Manual Displacement Servo Control Valve

- Low operator effort.
- Modular design.

### E. Input Shaft and Mounting

- SAE "B" or "B-B" Mount (2 Bolt)
- Numerous shaft options.

### F. Seals

### G. Bearings

### H. Swashplate Cradle

### I. Swashplate Bushing

### J. Swashplate

### K. Rotating Group

- 40,6 cm<sup>3</sup>/r [2.48 in<sup>3</sup>/r] Displacement
- 49,2 cm<sup>3</sup>/r [3.00 in<sup>3</sup>/r] Displacement

### L. Valve plate

- Improved serviceability.

### M. Servo Piston Assembly

### N. Bypass Valve

- Cross ports the closed loop hydraulic circuit - used to move a disabled machine a limited distance.

### O. Internal High Pressure Relief Valves

- prevents excessive pressure.

### P. Gerotor Charge Pump

- Two sizes available
  - 6,9 cm<sup>3</sup>/r [.42 in<sup>3</sup>/r]
  - 13,8 cm<sup>3</sup>/r [.84 in<sup>3</sup>/r]

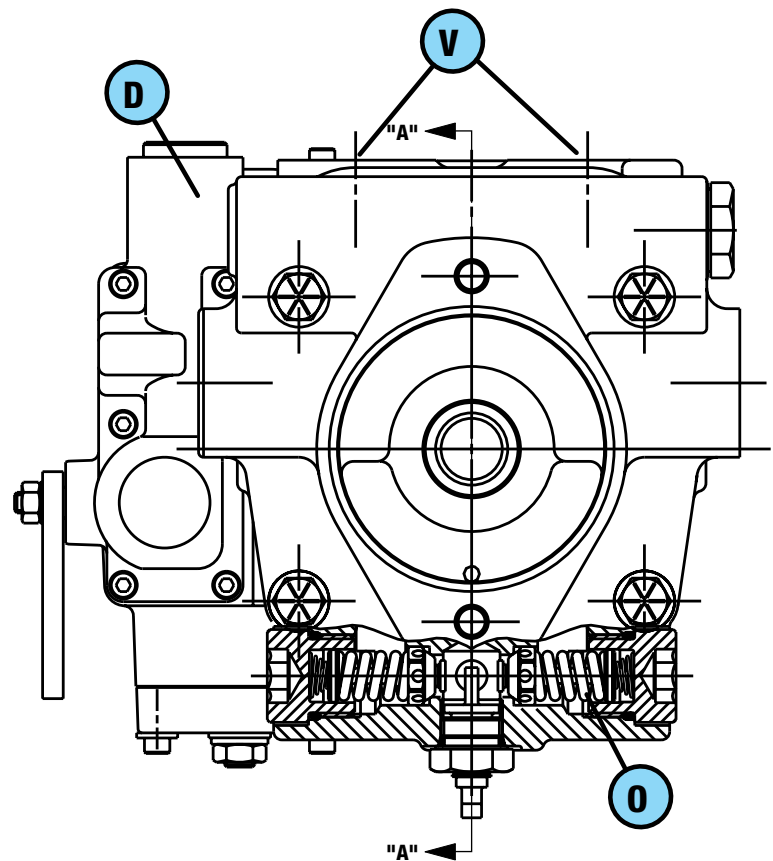

### Q. Auxiliary Pump Mounting Flange (Rear)

- SAE "A" or "B"

### R. Case Drain Port

### S. Auxiliary Port

- For pressure check port or remote charge pressure port.

### T. Control Lever

### U. Control Orifices

- Controls rate of change of displacement.

### V. Main System Ports

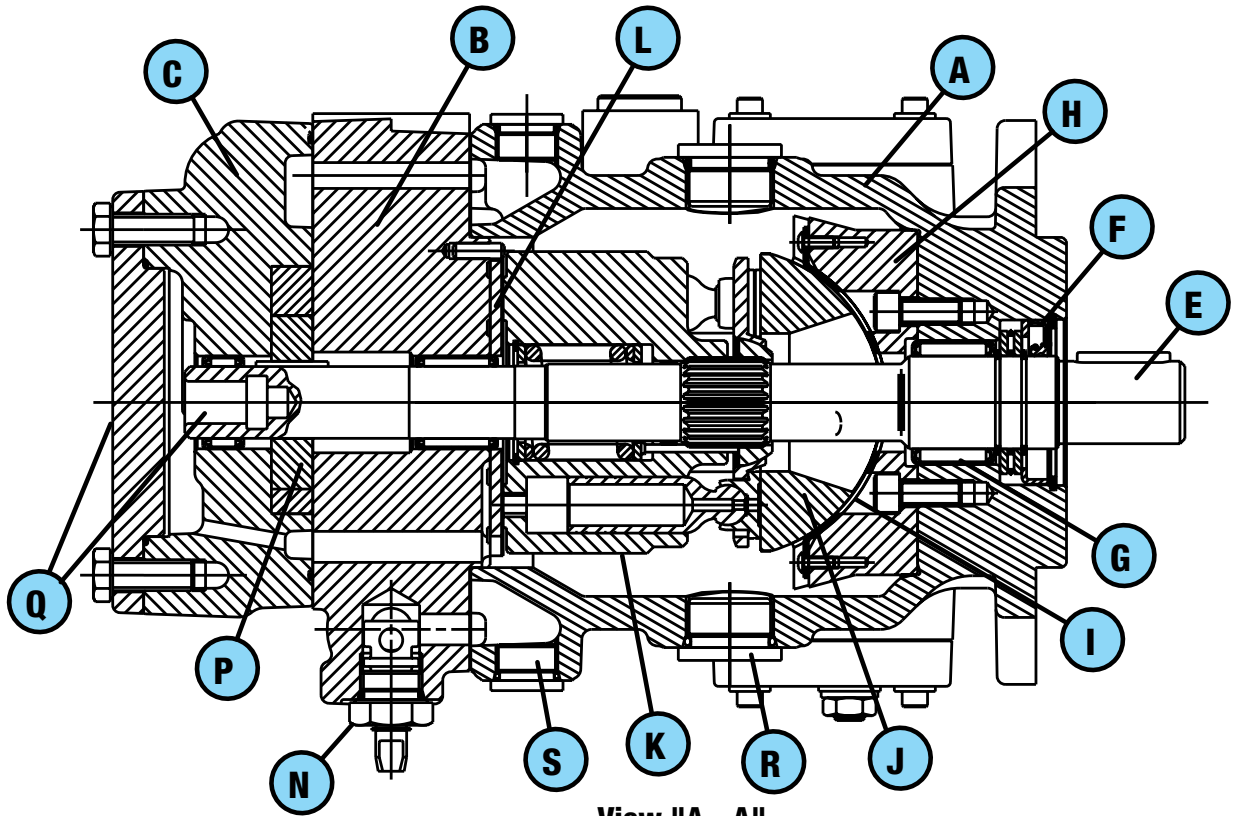

View "A - A"

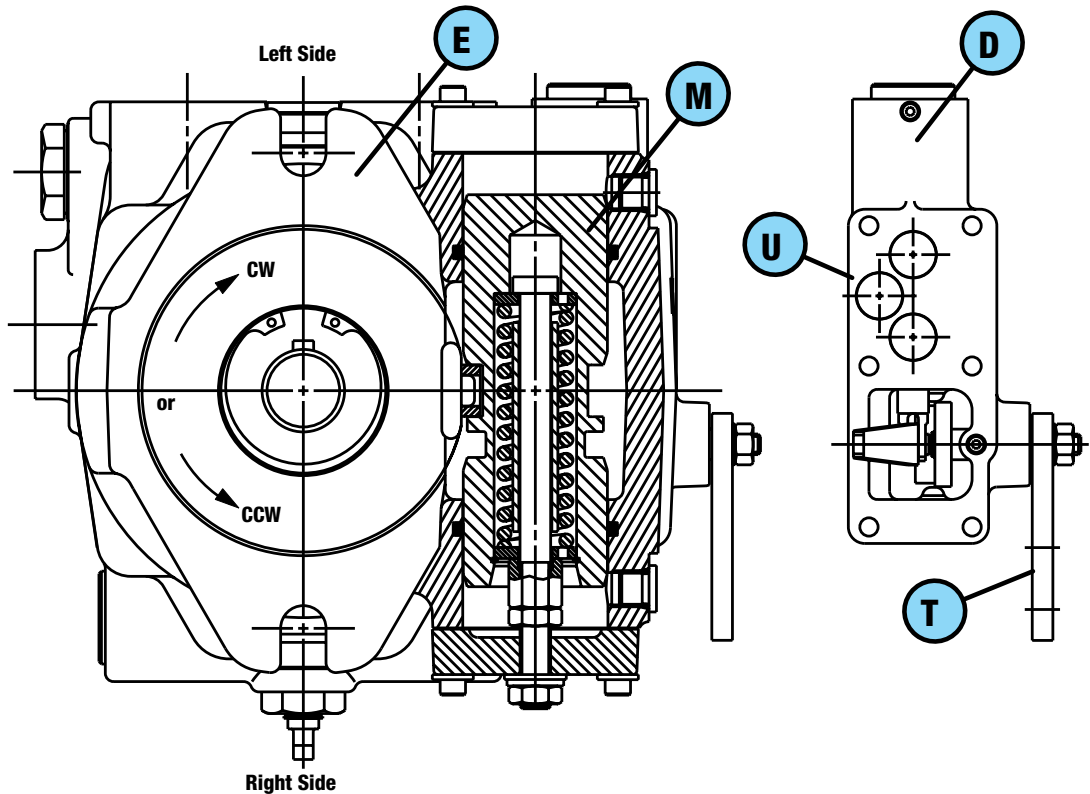

Model 72400

Installation Drawing - Model 72400 Servo Controlled Single Piston Pump



Lever Position vs. Pressurized Port	
Righthand (CW) Rotation	
Lever position "A"---	Port (A) is Pressurized
Lever position "B"---	Port (B) is Pressurized
Lefthand (CCW) Rotation	
Lever position "A"---	Port (B) is Pressurized
Lever position "B"---	Port (A) is Pressurized

This unit will accept another unit with an SAE "A" Auxiliary Mounting Flange and 15,7 [.62] Dia. 9 Tooth, 16/32 DP 30 involute flat root, class 1, side fit spline SAE J498b. Additional units driven by this spline must not require more than 54 N-m [480 lbf-in] of torque.

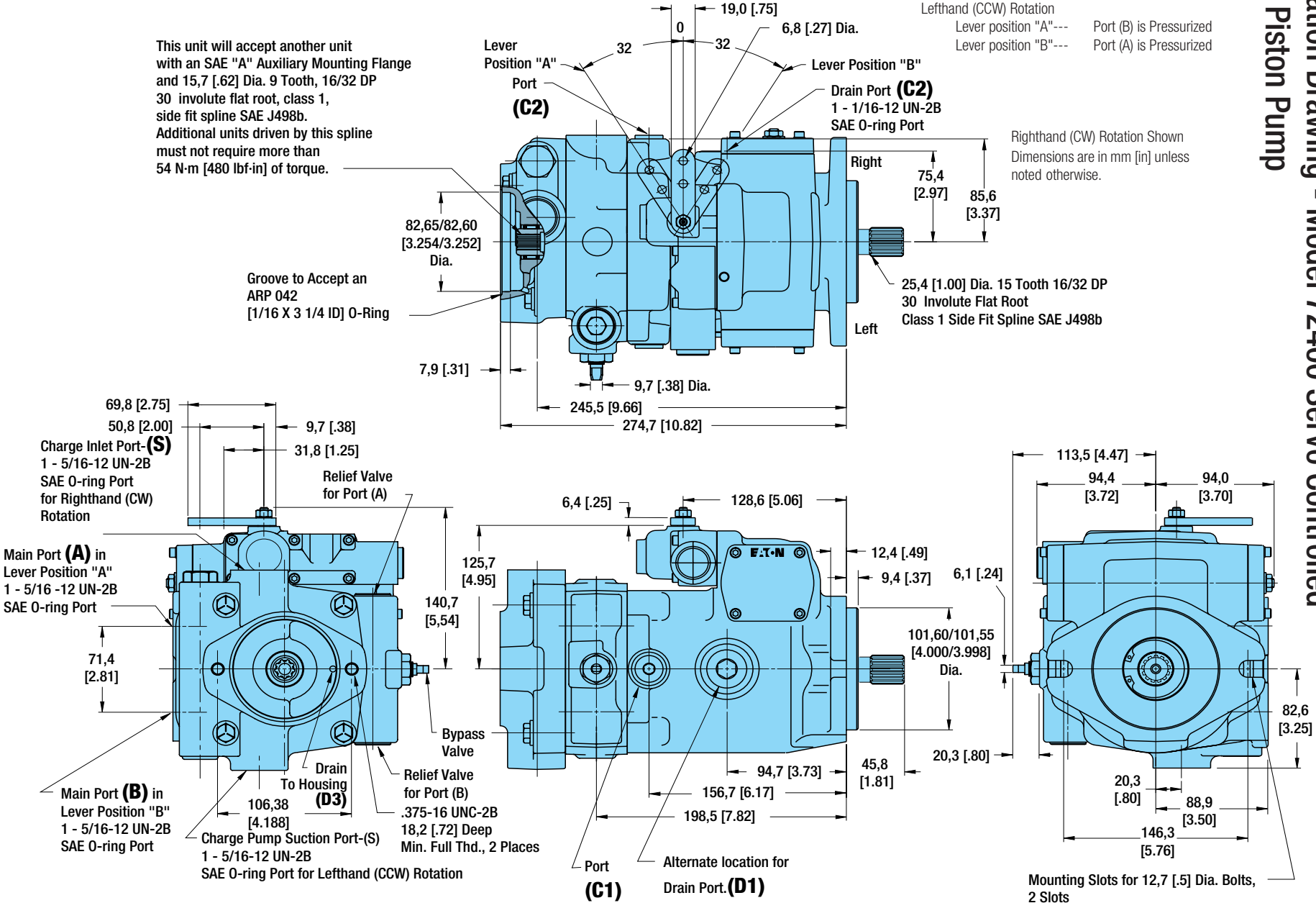

Righthand (CW) Rotation Shown  
Dimensions are in mm [in] unless noted otherwise.



# Model 72400 Servo Controlled Single Piston Pump

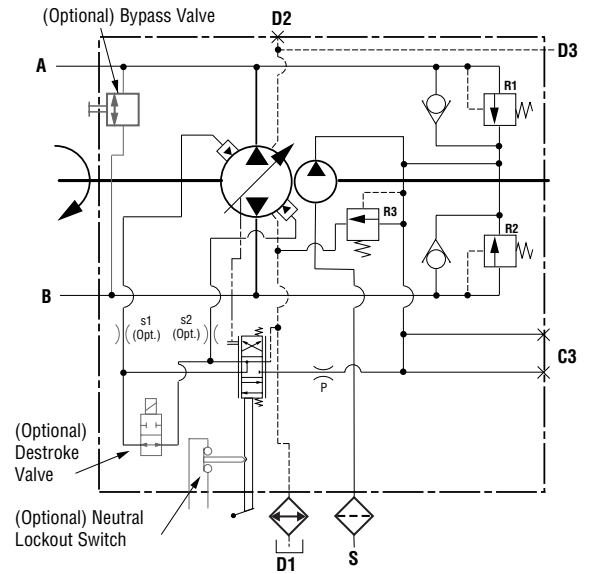
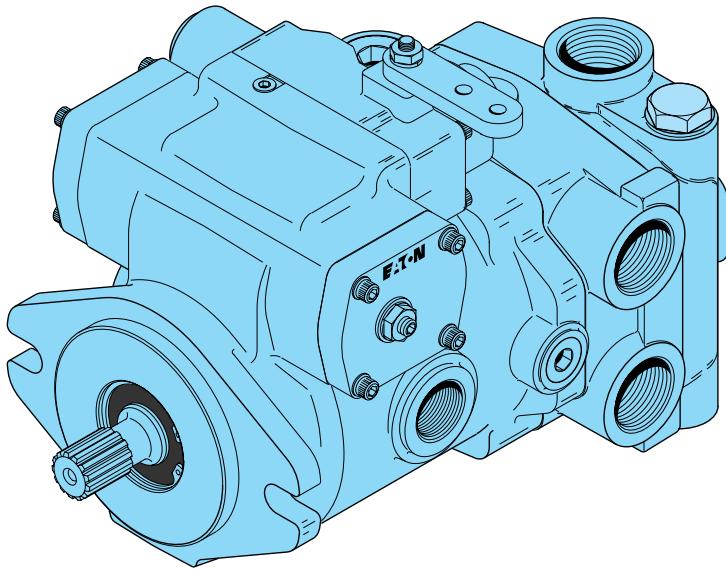

## Description of Unit on Opposite Page:

- Righthand (CW) Rotation
- Input Shaft: 15 tooth
- Output Shaft: 9 tooth
- Auxiliary Rear Mounting: SAE "A" Series 82-2
- Charge Pump: 6,9 cm<sup>3</sup>/r [.42 in<sup>3</sup>/r] disp. with Inlet Port 1 - 5/16-12 UN-2B, SAE O-ring Port
- Charge Pump Relief Setting: 17 to 21 bar [250 to 300 PSI], relieved to case.
- Auxiliary Port: 3/4-16 UNF-2B, SAE O-ring Port, plugged on both sides.
- Drain Port: 1 - 1/16-12 UN-2B, SAE O-ring Port, on right side and rear flange drained into housing
- Main Ports: 1 - 5/16-12 UN-2B, SAE O-ring Port, same side on right
- Relief Valves: Available in a range of settings to 379 bar [5500 PSI]
- Additional Functions: Bypass Valve
- Control Assembly: Manual with no additional features
- Supply Orifice: .71 mm [.028 in]
- Paint: Black

Additional options are available by using the Model Code and Details.

All left (CCW) or right (CW) directions given are viewed from the input shaft end of the pump.

Assembly Dimensions - Model 72400 Servo Controlled  
Front Piston Pump of Tandem Pumps

Lever Position vs. Pressurized Port

Righthand (CW) Rotation	Lever position "A"---	Port (A) is Pressurized
	Lever position "B"---	Port (B) is Pressurized
Lefthand (CCW) Rotation	Lever position "A"---	Port (B) is Pressurized
	Lever position "B"---	Port (A) is Pressurized

Righthand (CW) Rotation Shown  
Dimensions are in mm [in] unless noted otherwise.

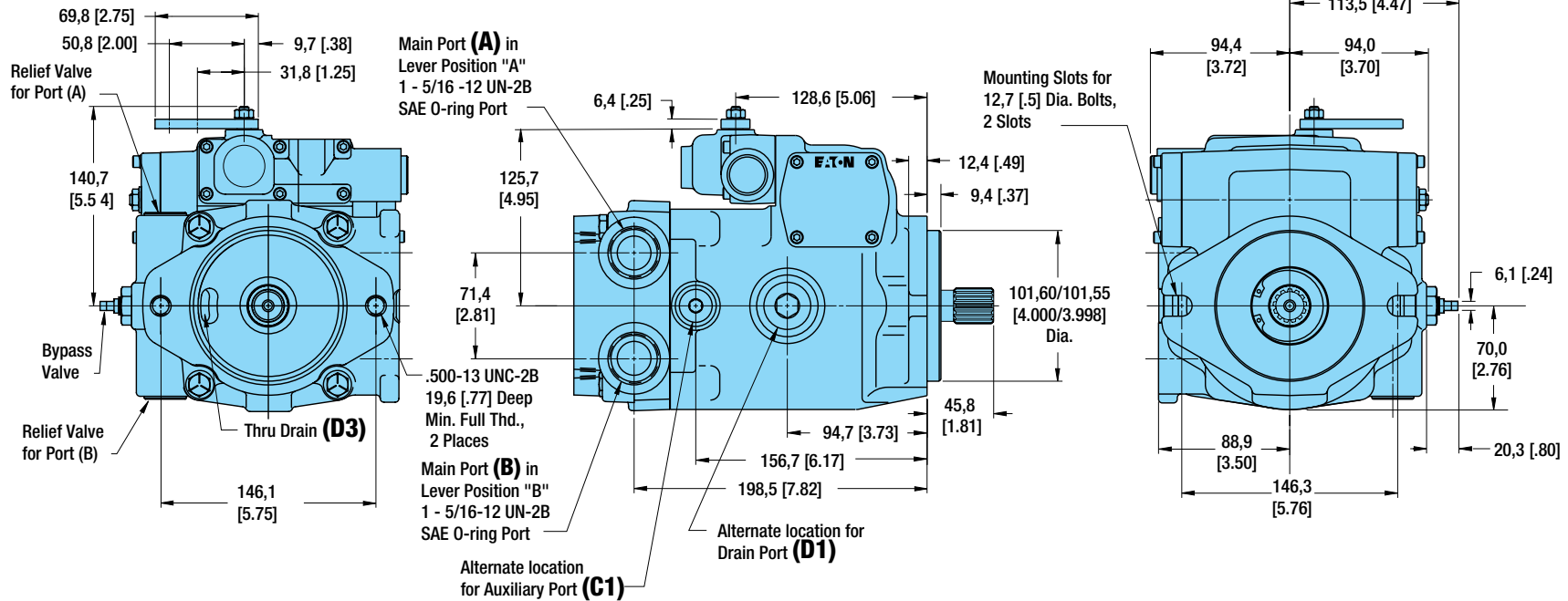
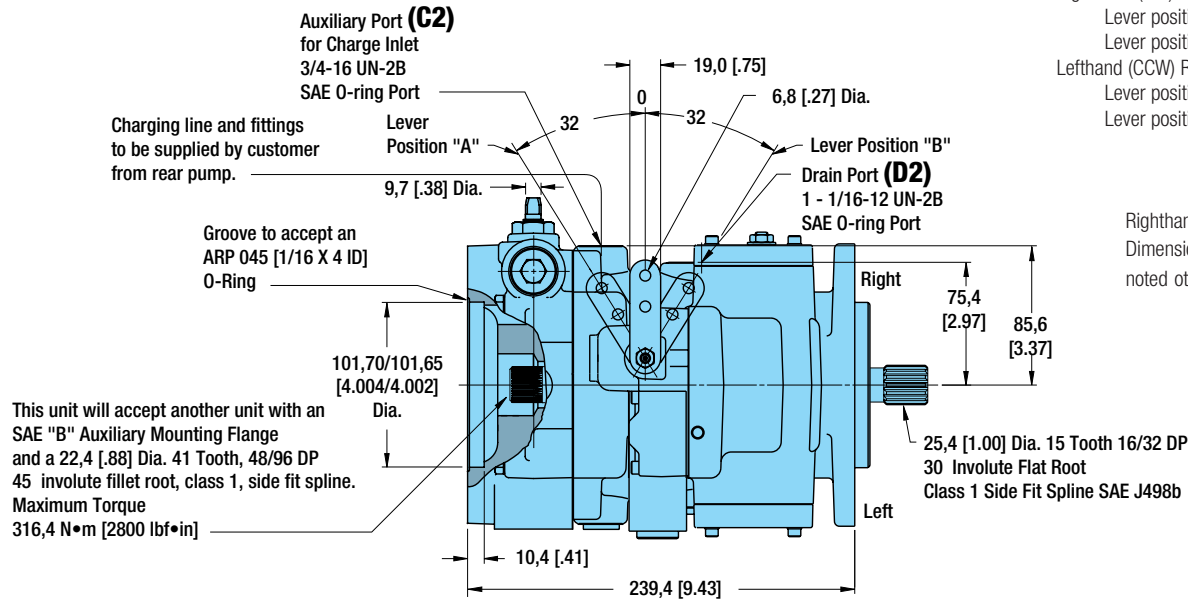

# Model 72400 Servo Controlled Front Piston Pump of Tandem Pumps

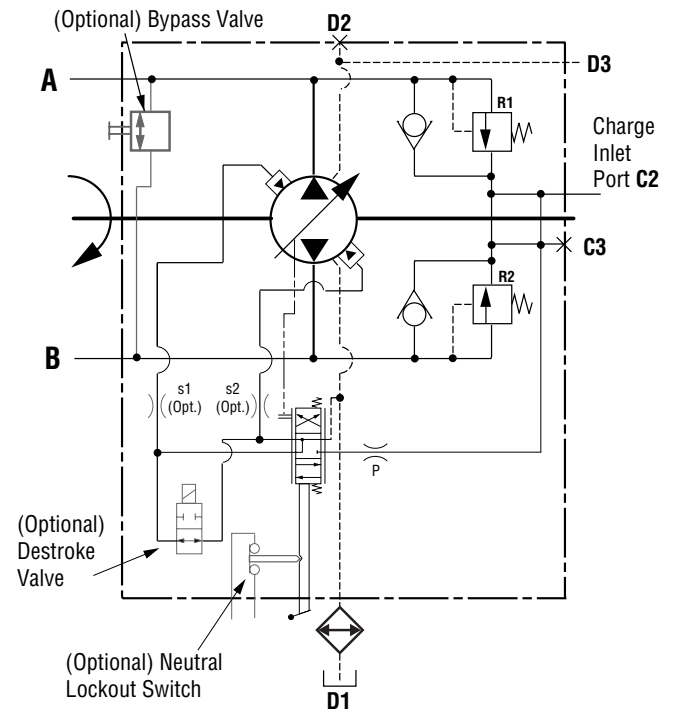
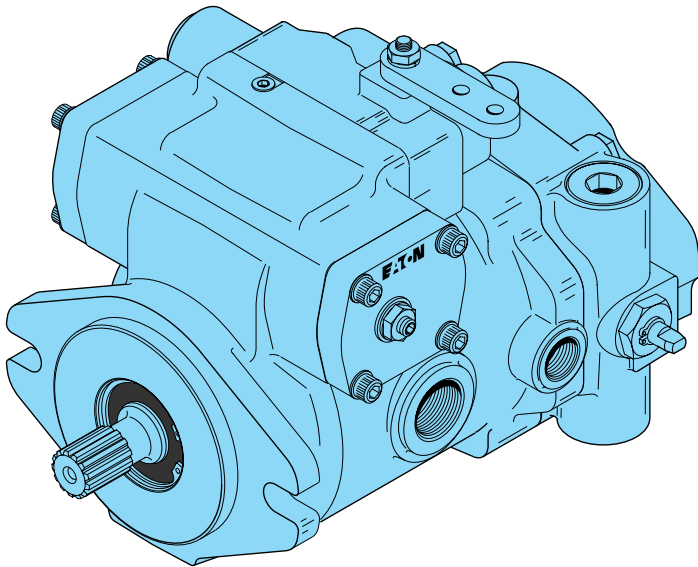

## Description of Unit on Opposite Page:

- Righthand (CW) Rotation
- Input Shaft: 15 tooth
- Output Shaft: 41 tooth
- Auxiliary Rear Mounting: SAE 2 bolt "B" Series 101-2
- Charge Pump: Not included
- Auxiliary Port: 3/4-16 UNF-2B SAE O-ring Port on right side
- Drain Port: 1 - 1/16-12 UN-2B SAE O-ring Port on right side and rear flange drained into housing
- Main Ports: 1 - 5/16-12 UN-2B SAE O-ring Port on same side (left side of pump)
- Relief Valves: Available in a range of settings to 379 bar [5500 PSI]
- Additional Functions: Bypass Valve
- Control Assembly: Manual with no additional features
- Supply Orifice: ,71 mm [.028 in]
- Paint: Black

Additional options are available by using the Model Code and Details.

All left (CCW) or right (CW) directions given are viewed from the input shaft end of the pump.

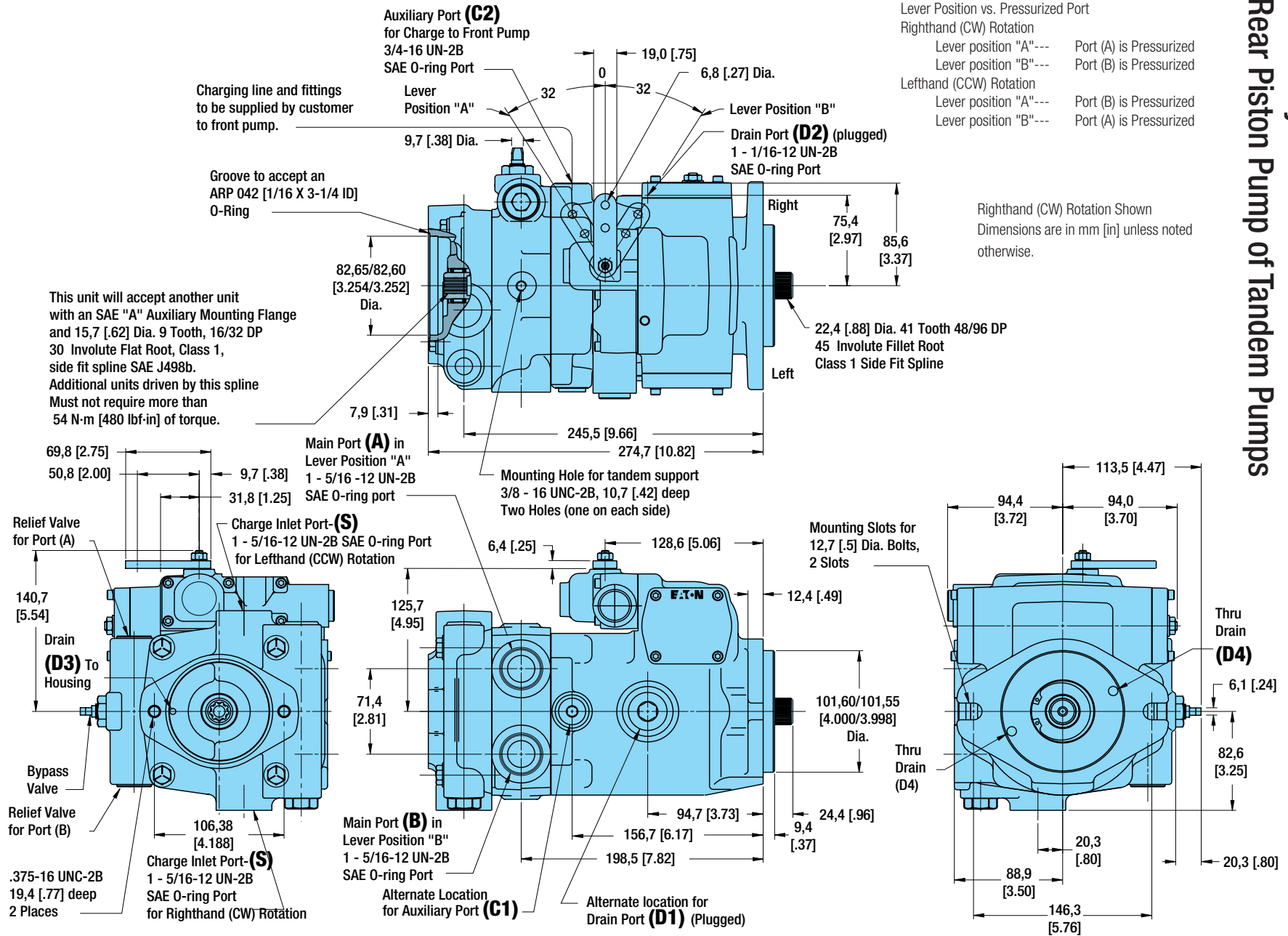

Lever Position vs. Pressurized Port

Righthand (CW) Rotation  
Lever position "A"--- Port (A) is Pressurized  
Lever position "B"--- Port (B) is Pressurized

Lefthand (CCW) Rotation  
Lever position "A"--- Port (B) is Pressurized  
Lever position "B"--- Port (A) is Pressurized

Righthand (CW) Rotation Shown  
Dimensions are in mm [in] unless noted otherwise.

Rear Piston Pump of Tandem Pumps

Assembly Dimensions - Model 72400 Servo Controlled

Medium Duty Piston Pump



# Model 72400 Servo Controlled Rear Piston Pump of Tandem Pumps

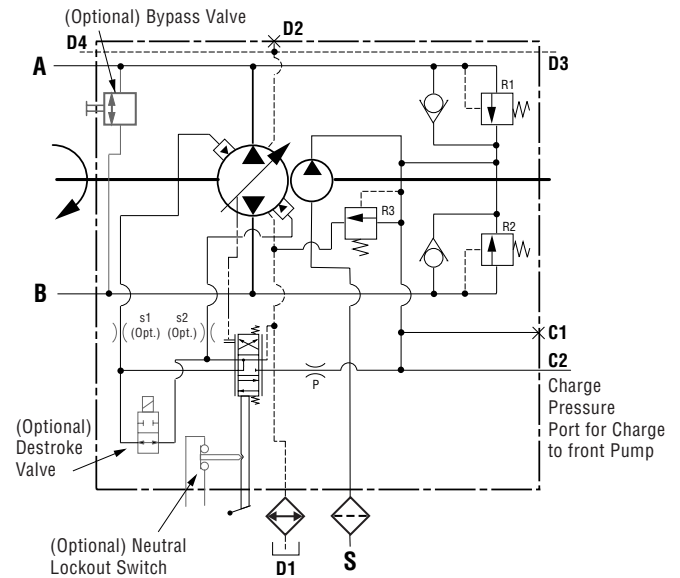
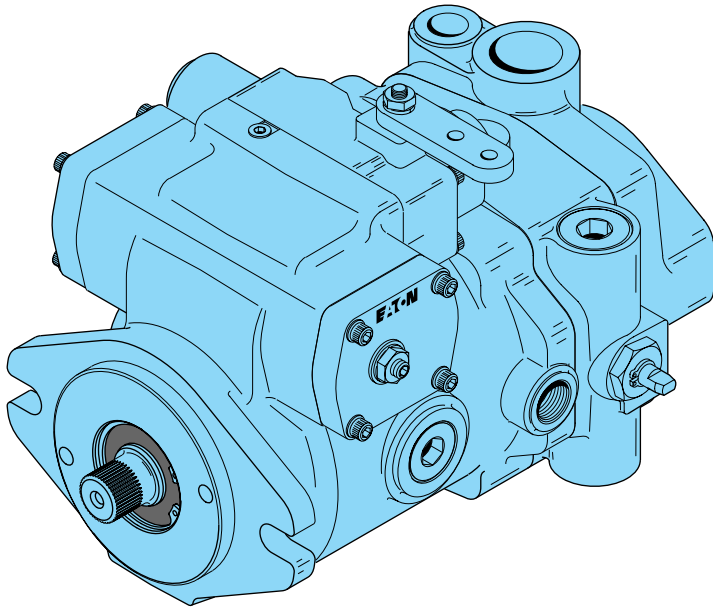

## Description of Unit on Opposite Page:

- Righthand (CW) Rotation
- Input Shaft: 41 tooth
- Output Shaft: 9 tooth
- Auxiliary Rear Mounting: SAE "A" Series 82-2 w/mounting support hole
- Charge Pump: 13,8 cm<sup>3</sup>/r [.84 in<sup>3</sup>/r] disp. with Inlet Port, 1 - 5/16-12 UN-2B SAE O-ring Port
- Charge Pump Relief Setting: 17 to 21 bar [250 to 300 PSI], Relieved to Case.
- Auxiliary Port: 3/4-16 UNF-2B SAE O-ring Port on right side
- Drain Port: 1 - 1/16-12 UN-2B SAE O-ring Port on both sides, plugged, and drain hole thru housing to front pump.
- Main Ports: 1 - 5/16-12 UN-2B SAE O-ring Port same side on left
- Relief Valves: Available in a range of settings to 379 bar [5500 PSI]
- Additional Functions: Bypass Valve
- Control Assembly: Manual with no additional features
- Supply Orifice: .71 mm [.028 in]
- Paint: Black

Additional options are available by using the Model Code and Details.

All left (CCW) or right (CW) directions given are viewed from the input shaft end of the pump.

# Model 72400

## Features, Benefits & Specifications

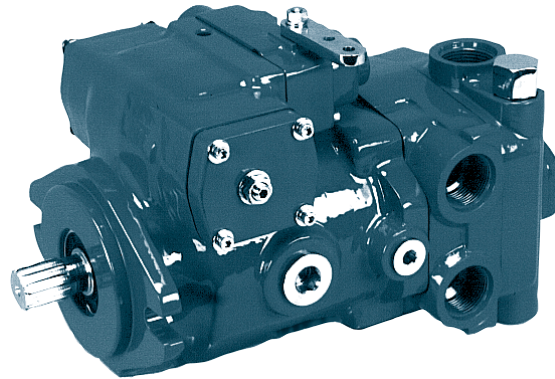

### Features

- Modular design
- Durable cast iron housing
- Multiple drain options
- SAE "B" or "B-B" Mount (2 Bolt) Flange
- Numerous shaft options
- Auxiliary or tandem mount capability
- Charge pump
- Control options

### Benefits

- Compact package size
- Quiet operation
- Low operator effort
- Improved serviceability

### Model 72400

#### Specifications - Piston Pump

Maximum Displacement .....	40,6 cm <sup>3</sup> /r [2.48 in <sup>3</sup> /r]	49,2 cm <sup>3</sup> /r [3.00 in <sup>3</sup> /r]
Input Mounting Flange .....	SAE "B" or "BB"	SAE "B" or "BB"
Flow @ Rated Speed & PSI .....	140 l/min [37.0 gal/min]	170 l/min [44.8 gal/min]
Maximum Rated Speed .....	3600 RPM	3600 RPM
Continuous Rated Pressure .....	210 bar [3000 PSI]	210 bar [3000 PSI]
Maximum Intermittent Pressure .....	379 bar [5500 PSI]	345 bar [5000 PSI]
Continuous Allowable		
Case Pressure .....	2 bar [25 PSI]	2 bar [25 PSI]
Maximum Case Drain		
Temperature .....	107° C [225° F]	107° C [225° F]
Weight per single pump (aprox.) .....	27 to 28 kg [59 to 62 lbs]	27 to 28 kg [59 to 62 lbs]

#### Specifications - Internal Gerotor Charge Pump

Displacement Options	
.....	6,9 cm <sup>3</sup> /r [.42 in <sup>3</sup> /r]
.....	13,8 cm <sup>3</sup> /r [.84 in <sup>3</sup> /r]
Operating Pressure Range (std.) .....	17 to 21 bar [250 to 300 PSI]
Maximum Charge Inlet Vacuum .....	0,80 bar Abs. [6 inHg]

# Model 72400 Performance Data

The charts below are representative of a single 40,6 cm<sup>3</sup>/r [2.48 in<sup>3</sup>/r] Variable Displacement Piston Pump. The tests were run at an oil temperature of 82°C [180°F] with viscosity at 9 - 12 cSt [54 - 66 SUS] and the pump at maximum displacement.

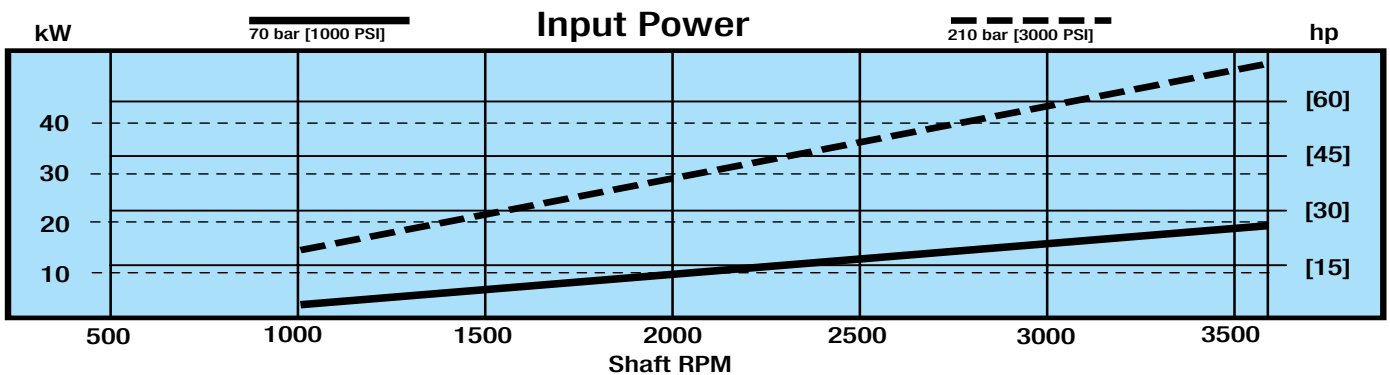
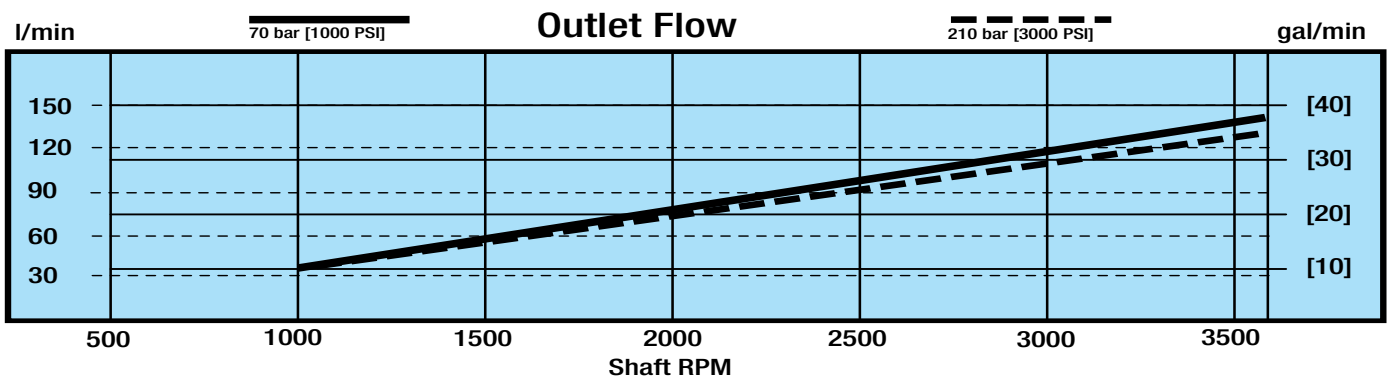
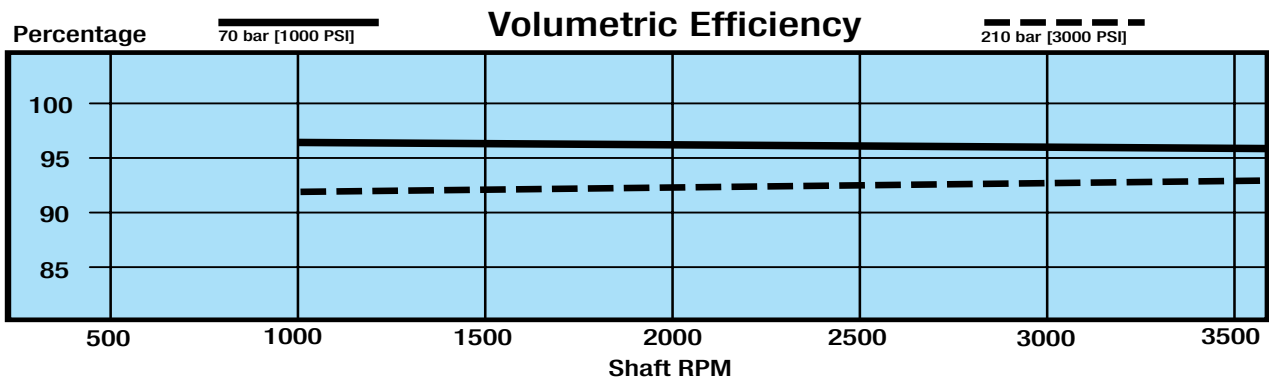
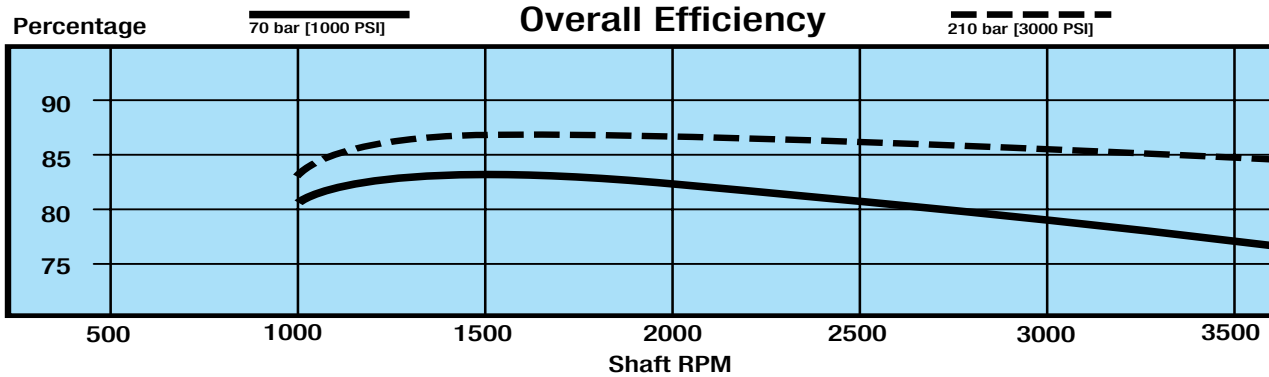

Model 72400

## Medium Duty Piston Pump

# Model Code for the 72400 Piston Pumps

### Ordering Instructions

The Model 72400 Servo Controlled piston pumps are selected by using the following Model Code System tailoring the pump configuration to the requirement. Once a pump is built from the model code, a product number will be assigned to that configuration and the pump identified.

Make sure all positions are selected within the 27-digit code for each pump ordered.

<b>Code Example:</b>	A	A	D	R	A	A	A	1	3	E	E	1	T	T	A	M	O	O	A	O	O	O	A	O	O	O	O
<b>Position:</b>	1	2	3	4	5	6	7	8	9	10	11	12	13	14	15	16	17	18	19	20	21	22	23	24	25	26	27
																					0	0	A			0	D

#### Positions 1, 2, 3 - Code Title

- AAD = 40,6 cm³/r [2.48 in³/r] Servo Controlled Variable Displacement Pump
- AAE = 40,6 cm³/r [2.48 in³/r] Servo Controlled Variable Displacement Pump (Tandem Front Pump)
- AAF = 40,6 cm³/r [2.48 in³/r] Servo Controlled Variable Displacement Pump (Tandem Rear Pump)
- ACG = 49,2 cm³/r [3.00 in³/r] Servo Controlled Variable Displacement Pump
- ACH = 49,2 cm³/r [3.00 in³/r] Servo Controlled Variable Displacement Pump (Tandem Front Pump)
- ACJ = 49,2 cm³/r [3.00 in³/r] Servo Controlled Variable Displacement Pump (Tandem Rear Pump)

#### Position 4 - Input Shaft Rotation

- R = Righthand Rotation (CW)
- L = Lefthand Rotation (CCW)

#### Position 5 - Input Shaft

- A = 15 Tooth, 16/32 External Spline, 46 [1.81] Shaft Extension ..... A
- B = 41 Tooth, 48/96 External Spline, 24,4 [96] Shaft Extension ..... B
- C = 13 Tooth, 16/32 External Spline, 41,1 [1.62] Shaft Extension ..... C
- D = Taper 1.502:12, 6,4 [25] x 19,8 [78] keyway, 3/8 - 24 UNF Int. Thread, 35,1[1.38] Shaft Extension ..... D
- G = 25.4 [1.00] Dia. Str., 6,4 [25] x 28,4 [1.12] keyway, 46 [1.81] Shaft Extension (Key Included) ..... G

#### Position 6 - Output Shaft

- A = 9 Tooth, 16/32 Internal Spline, Accepts 31,8 [1.25] Shaft Extension (for SAE "A" mount only) ..... A
- B = 41 Tooth, 48/96 External Spline, Accepts 24,4 [96] Shaft Extension (for SAE "B" mount only) ..... B
- F = 11 Tooth, 16/32 Internal Spline, Accepts 31,8 [1.25] Shaft Extension (for SAE "A" mount only) ..... F
- J = 11 Tooth, 16/32 External Spline, Accepts 31,8 [1.25] Shaft Extension (for SAE "B" mount only) ..... J
- (To be used with 36,8 [1.45] spacer) ..... J

#### Position 7 - Auxiliary Rear Mounting

- A = "A" SAE Flange Series 82-2 ..... A
- B = 2 Bolt "B" SAE Flange Series 101-2 ..... B
- C = "A" SAE Flange Series 82-2 w/ Cover Plate ..... C
- D = "A" SAE Flange Series 82-2 w/ Cover Plate and Mounting Support Holes ..... D
- E = "A" SAE Flange Series 82-2 w/ Mounting Support Holes ..... E
- F = 2 Bolt "B" SAE Flange Series 101-2 w/ Mounting Support Holes ..... F

#### Position 8 - Charge Pump

- 0 = No charge pump ..... 0
- 1 = 6,9 cm³/r [4.2 in³/r] disp. w/1-5/16 - 12 UN-2B SAE O-ring straight thread inlet port (S) ..... 1
- 2 = 13,8 cm³/r [8.4 in³/r] disp. w/1-5/16 - 12 UN-2B SAE O-ring straight thread inlet port (S) ..... 2

#### Position 9 - Charge Pump Relief Setting and Routing

- 0 = No charge pump ..... 0
- 3 = 17- 21 bar [250-300 PSI] (Relieved to Case) ..... 3
- 4 = 17- 21 bar [250-300 PSI], 1- 5/16 - 12 UN-2B SAE O-ring straight thread Outlet port (C3), 3/4 - 16 UNF-2B SAE O-ring straight thread Return Port (C4), (Remote filter and/or heat exchanger, relieved to case) ..... 4

#### Position 10 - Auxiliary Port, Size and Location (left C1 and right C2)

- D = On both sides w/left side plugged (housing), 3/4 - 16 UNF-2B SAE O-ring straight thread port ..... D
- E = On both sides and both plugged (housing), 3/4 - 16 UNF-2B SAE O-ring straight thread port ..... E

#### Position 11 - Drain Port Size and Location (left D1 and right D2)

- D = On both sides w/ right side plugged & rear flange drained into housing, 1-1/16 - 12 UN-2B SAE O-ring straight thread port ..... D
- E = On both Sides w/ left side plugged & rear flange drained into housing, 1-1/16 - 12 UN-2B SAE O-ring straight thread port ..... E
- M = On both sides w/ left side plugged & thru drain into mount (front), 1-1/16 - 12 UN-2B SAE O-ring straight thread port ..... M
- S = On both sides w/ both sides plugged & thru drain into mount (front), 1-1/16 - 12 UN-2B SAE O-ring straight thread port ..... S

#### Position 12 - Main Ports, Size and Location (port A and B)

- 1 = 1- 5/16 - 12 UN-2B O-ring straight thread port, Same Side (Right Side) ..... 1
- 2 = 1- 5/16 - 12 UN-2B O-ring straight thread port, Same Side (Left Side) ..... 2

#### Positions 13, 14 - Relief Valve Setting for Main Ports

(Select a Setting for port "A" in position 13 and port "B" in Position 14)

- 0 = Check Valve Only ..... 0
- B = 140 bar [2000 PSI] ..... B
- E = 175 bar [2500 PSI] ..... E
- H = 210 bar [3000 PSI] ..... H
- L = 240 bar [3500 PSI] ..... L

Code	Single Unit	Tandem Unit	
		Front	Rear
A	Std.	Std.	NA
B	NA	NA	Std.
C	Opt.	NA	NA
D	Opt.	Opt.	NA
G	Opt.	NA	NA
A	Std.	NA	Std.
B	NA	Std.	NA
F	Opt.	NA	Opt.
J	Opt.	NA	Opt.
A	Std.	NA	Opt.
B	Opt.	Std.	Opt.
C	Opt.	NA	Opt.
D	Opt.	NA	Opt.
E	Opt.	NA	Std.
F	Opt.	Opt.	Opt.
0	Opt.	Std.	Opt.
1	Std.	NA	NA
2	Opt.	NA	Std.
0	Opt.	Std.	Opt.
3	Std.	NA	Std.
4	Opt.	NA	Opt.
D	Opt.	Std.	Std.
E	Std.	NA	NA
D	Opt.	Opt.	NA
E	Std.	Std.	NA
M	NA	NA	Opt.
S	NA	NA	Std.
1	Std.	Opt.	Opt.
2	Opt.	Std.	Std.
0	Opt.	Opt.	Opt.
B	Opt.	Opt.	Opt.
E	Opt.	Opt.	Opt.
H	Opt.	Opt.	Opt.
L	Opt.	Opt.	Opt.



# Model Code for the 72400 Piston Pumps

	Code	Single Unit	Tandem Unit	
			Front	Rear
N = 275 bar [4000 PSI] .....	N	Opt.	Opt.	Opt.
Q = 310 bar [4500 PSI] .....	Q	Opt.	Opt.	Opt.
T = 345 bar [5000 PSI] .....	T	Std.	Std.	Std.
Y = 379 bar [5500 PSI] .....	Y	Opt.	Opt.	Opt.
<b>Position 15 - Additional Functions</b>				
0 = No Additional Functions .....	0	Std.	Std.	Std.
A = Bypass Valve .....	A	Opt.	Opt.	Opt.
<b>Positions 16, 17 - Control Assembly</b>				
Manual Control				
MO = No Additional Features .....	MO	Std.	Std.	Std.
MA = Neutral Lockout Switch (Includes Wide Band Neutral) .....	MA	Opt.	Opt.	Opt.
MB = Neutral Detent (Includes Wide Band Neutral) .....	MB	Opt.	Opt.	Opt.
MC = Wide Band Neutral .....	MC	Opt.	Opt.	Opt.
Port Plate				
P0 = No Additional Features .....	P0	Opt.	Opt.	Opt.
Hydraulic Remote Control				
HA = 5-15 bar [72-217 PSI] Pilot Pressure range, 2X Port .4375-20 UNF-2B SAE O-ring Port .....	HA	Opt.	Opt.	Opt.
Electrohydraulic Control				
EC = Electronic Proportional Control 12 Vdc without Electronic Driver .....	EC	Opt.	Opt.	Opt.
ED = Electronic Proportional Control 24 Vdc without Electronic Driver .....	ED	Opt.	Opt.	Opt.
EE = Electronic Proportional Control 12/24 Vdc and Electronic Driver with 1 to 6 Vdc Potentiometric Command Input .....	EE	Opt.	Opt.	Opt.
EG = Electronic Proportional Control 12/24 Vdc and Electronic Driver with 4 to 20 mA Command Input .....	EG	Opt.	Opt.	Opt.
EL = Electronic Proportional Control 12 Vdc and Electronic Driver with ± 100 mA Command Input .....	EL	Opt.	Opt.	Opt.
Solenoid Operated				
SA = 3 pos (FNR) 12 Vdc solenoids with Weather Pack Connectors (locations at port s1 and s2) .....	SA	Opt.	Opt.	Opt.
SB = 2 pos 12 Vdc solenoid with Weather Pack Connectors (location at port s1) .....	SB	Opt.	Opt.	Opt.
SC = 2 pos 12 Vdc solenoid with Weather Pack Connectors (location at port s2) .....	SC	Opt.	Opt.	Opt.
<b>Position 18 - Destroke Valve</b>				
0 = Not required .....	0	Std.	Std.	Std.
1 = with 12 VDC Coil and Weather Pack Connector .....	1	Opt.	Opt.	Opt.
2 = with 24 VDC Coil and Weather Pack Connector .....	2	Opt.	Opt.	Opt.
3 = with 12 VDC Coil and DIN 43650 Connector .....	3	Opt.	Opt.	Opt.
4 = with 24 VDC Coil and DIN 43650 Connector .....	4	Opt.	Opt.	Opt.
<b>Position 19 - Supply Orifice (location p)</b>				
0 = No Supply Orifice (NA for pumps w/ destroke) .....	0	Opt.	Opt.	Opt.
A = 0,71 mm [.028 in] .....	A	Opt.	Opt.	Opt.
B = 0,81 mm [.032 in] .....	B	Opt.	Opt.	Opt.
C = 0,91 mm [.036 in] .....	C	Std.	Std.	Std.
D = 1,02 mm [.040 in] .....	D	Opt.	Opt.	Opt.
E = 1,12 mm [.044 in] .....	E	Opt.	Opt.	Opt.
F = 1,32 mm [.052 in] (Maximum orifice size if position 18 selection is 1 thru 4) .....	F	Opt.	Opt.	Opt.
G = 1,45 mm [.057 in] (NA for pumps w/ destroke) .....	G	Opt.	Opt.	Opt.
H = 1,65 mm [.065 in] (NA for pumps w/ destroke) .....	H	Opt.	Opt.	Opt.
J = 1,85 mm [.073 in] (NA for pumps w/ destroke) .....	J	Opt.	Opt.	Opt.
<b>Position 20 - Control Orifice (location s1 &amp; s2)</b>				
0 = No Control Orifice .....	0	Std.	Std.	Std.
A = 0,71 mm [.028 in] .....	A	Opt.	Opt.	Opt.
B = 0,81 mm [.032 in] .....	B	Opt.	Opt.	Opt.
C = 0,91 mm [.036 in] .....	C	Opt.	Opt.	Opt.
D = 1,02 mm [.040 in] .....	D	Opt.	Opt.	Opt.
E = 1,12 mm [.044 in] .....	E	Opt.	Opt.	Opt.
F = 1,32 mm [.052 in] .....	F	Opt.	Opt.	Opt.
G = 1,45 mm [.057 in] .....	G	Opt.	Opt.	Opt.
<b>Position 21 - Special Control Option</b>				
Manual Control (only)				
0 = No Special Control Options (Standard Control Lever Position) .....	0	Std.	Std.	Std.
<b>Positions 22, 23 - Paint</b>				
0A = Primer .....	0A	Std.	Std.	Std.
0B = Black .....	0B	Opt.	Opt.	Opt.
<b>Positions 24, 25 - Special Features</b>				
00 = No Special Features .....	00	Std.	Std.	Std.
BB = Adjustable Displacement Limiter, Both Sides .....	BB	Opt.	Opt.	Opt.
<b>Position 26 - Identification</b>				
0 = Standard .....	0	Std.	Std.	Std.
<b>Position 27 - Design Code</b>				
D = Eaton - assigned design code				

# 72400

## Input Shafts

### Code Position 5

Dimensions are in millimeters [inches], unless otherwise specified.

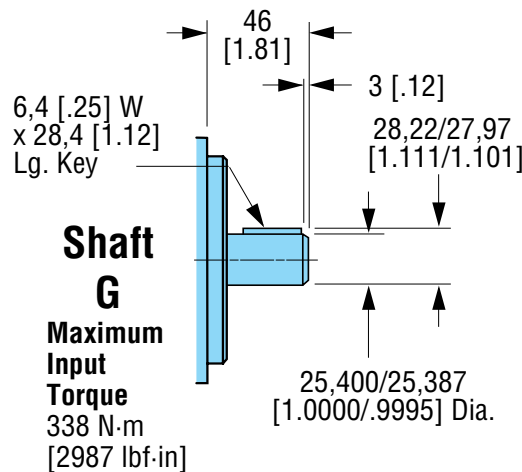
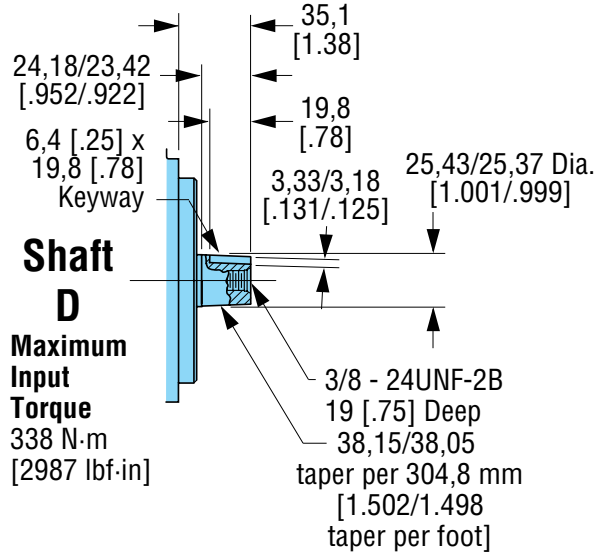
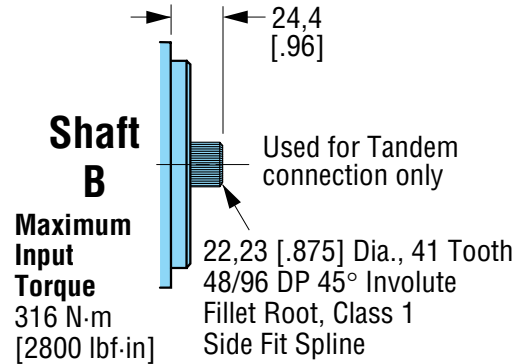
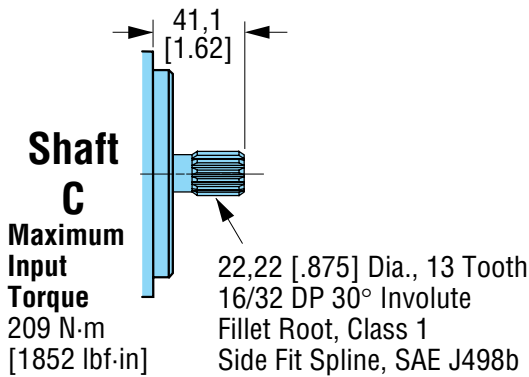
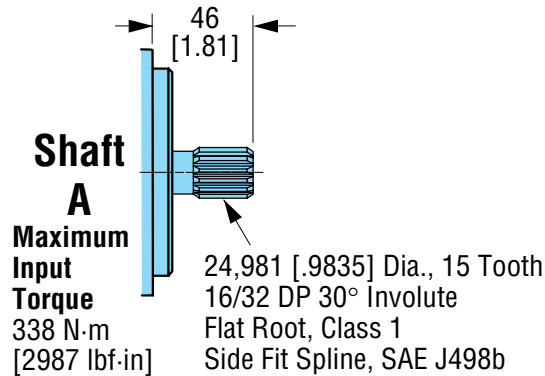

**Torque Note:**  
 The combined torque required to turn multiple pumps must not exceed the torque rating of the input drive shaft of the front piston pump.  
 Consult an Eaton representative and/or Eaton engineering on side load recommendations.

**Ordering Note:**  
 Input and output shafts (code position 5 & 6) must be selected in relationship to pump code (position 1, 2, & 3).

# 72400

## Output Shafts - Code Position 6

**9 Tooth**, 16/32 DP Int., 15,875  
 [.6250] O.D., Accepts 31,8 [1.25]  
 Shaft Extension, "A" Mount SAE J498b

**Position 6  
 Shaft A**

**Torque limit** on internal rear spline of piston pump with internal charge pump must not exceed 54 N·m [480 lbf·in]. Piston pump without internal charge pump must not exceed 76 N·m [672 lbf·in].

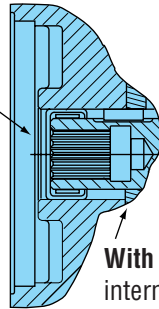

With internal charge.

**11 Tooth**, 16/32 DP Int., 19,33  
 [.761] O.D., Accepts 31,8 [1.25]  
 Shaft Extension, "A" Mount SAE J498b

**Position 6  
 Shaft F**  
**Maximum Torque**  
 119 N·m [1050 lbf·in]

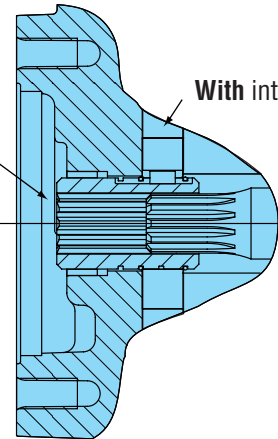

With internal charge.

**11 Tooth**, 16/32 DP Ext., 19,05  
 [.750] O.D., Accepts 31,8 [1.25]  
 Shaft Extension, "A" Mount SAE J498b  
 (Used with spacer)

**Position 6  
 Shaft J**  
**Maximum Torque**  
 119 N·m [1050 lbf·in]

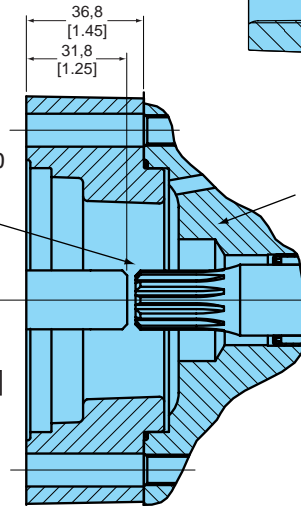

Without internal charge

**13 Tooth**, 16/32 DP External, 21,81  
 [.8585] O.D., Accepts 41,1 [1.62] Shaft  
 Extension "B" Auxiliary Mount,  
 SAE J744

**Position 6  
 Shaft L**  
**Maximum Torque**  
 209 N·m [1852 lbf·in]

Without internal charge

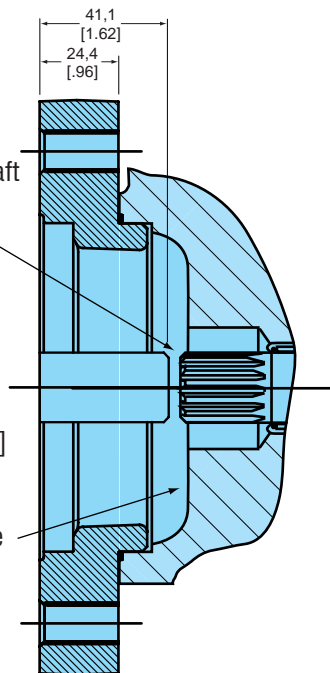

**41 Tooth**, 48/96 DP Extension, 22,225  
 [.8750] O.D., Accepts 24,4 [.96] Shaft  
 Extension "B" Auxiliary Mount,  
 SAE J498b

**Position 6  
 Shaft B**  
**Maximum Torque**  
 316 N·m [2,800 lbf·in]

**41 Tooth** for tandem connections on rear of front pump.

Tandem Servo Piston Pump  
 SAE "B" Mounting Kit #72400-902:  
 Includes 41T coupling, o-ring, cap screws (2),  
 and washer.

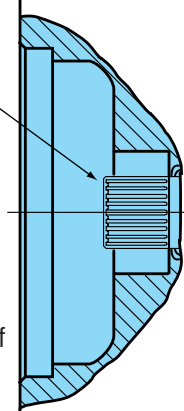

# 72400

## Auxiliary Rear Mounting

### Code Position 7

Dimensions are in millimeters [inches], unless otherwise specified.

**2 Bolt "A" Auxiliary Mounting Flange**  
(Rear of Single or Tandem Rear Pump)

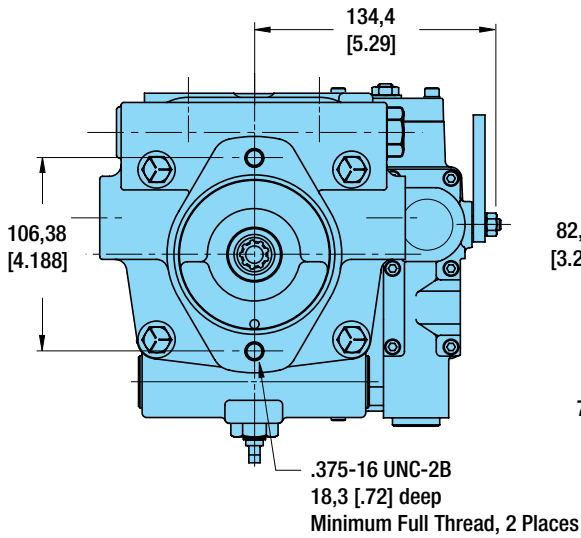

Groove to Accept an ARP 042  
[1/16 X 3-1/4 ID] O-Ring

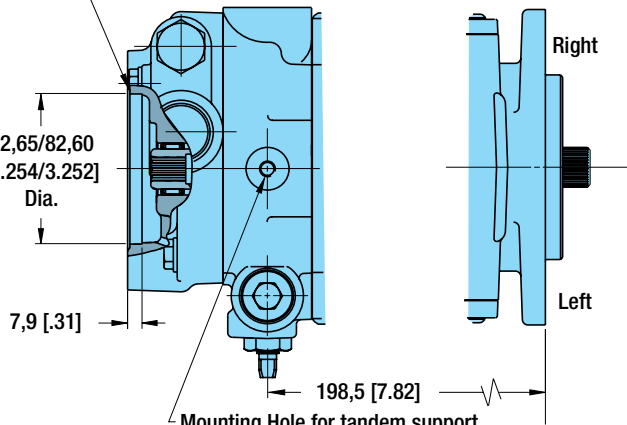

**2 Bolt "B" Auxiliary Mounting Flange**  
(Rear of Front Pump)

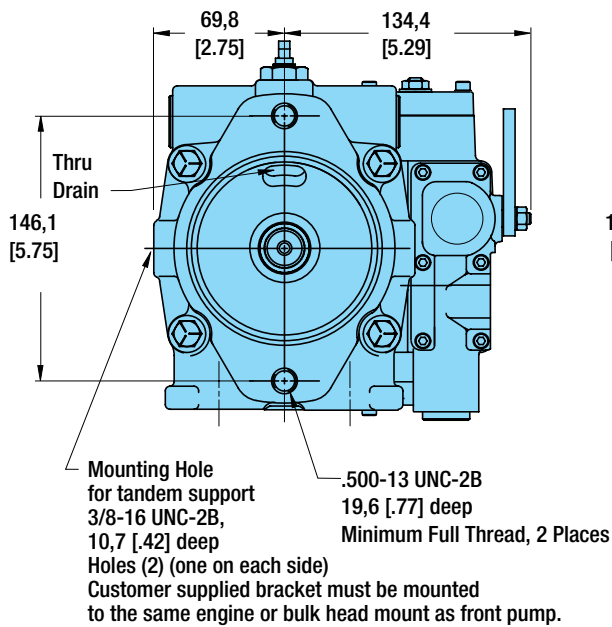

Groove to Accept an ARP 045  
[1/16 X 4 ID] O-Ring

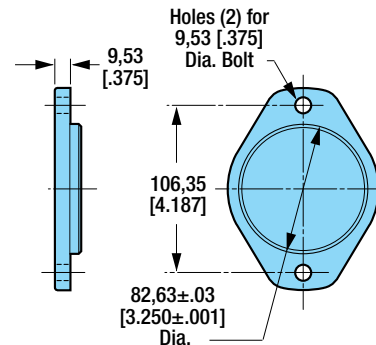
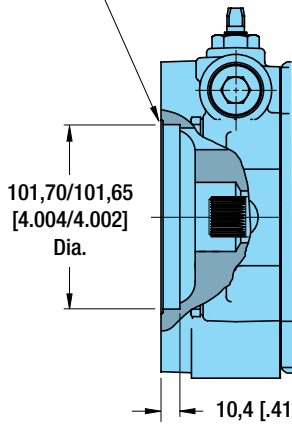

**Cover Plate**

Fits "A" SAE Auxiliary Mounting Flange.  
Cover Plate Kit #70142-915: Includes plate, cap screws (2), and o-ring.

Model 72400

# 72400

## Charge Pump Routing and Location

### Code Position 9

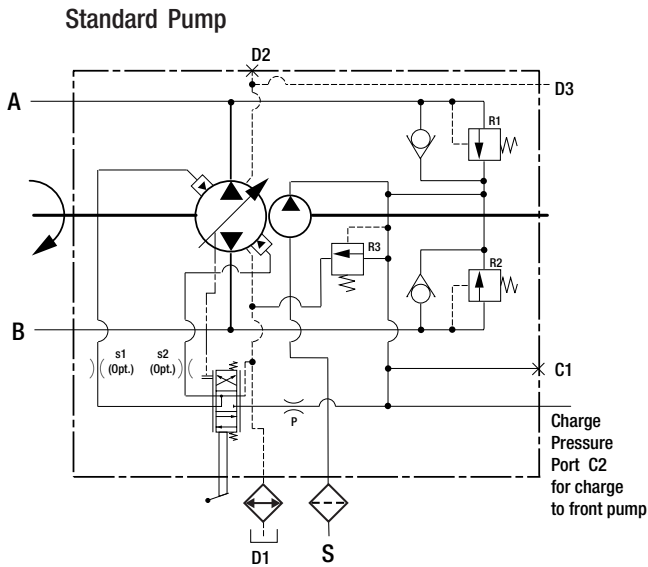

### Charge Pump with Remote Filter/ Heat Exchanger Ports

(Filter and heat exchanger supplied by customer.)

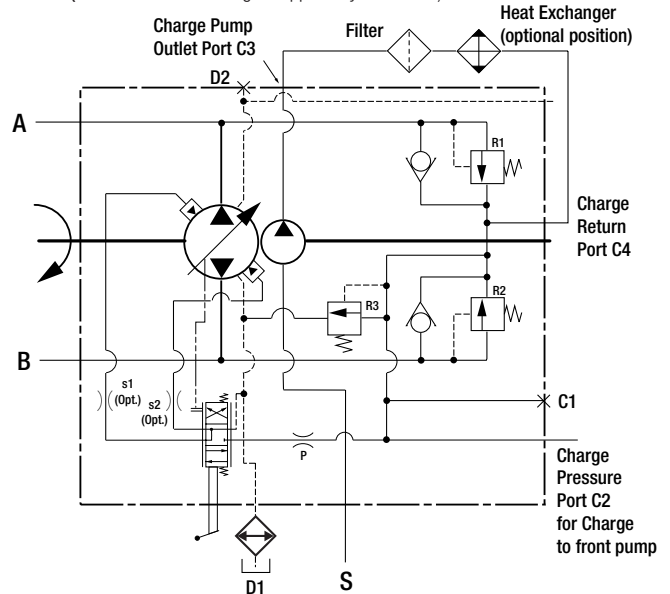

### Charge Outlet Port Location

The charge outlet and return port is located in the charge pump housing, opposite of the suction port and charge relief valve.

For further detail on port relationship to rotation and position, refer to installation drawings.

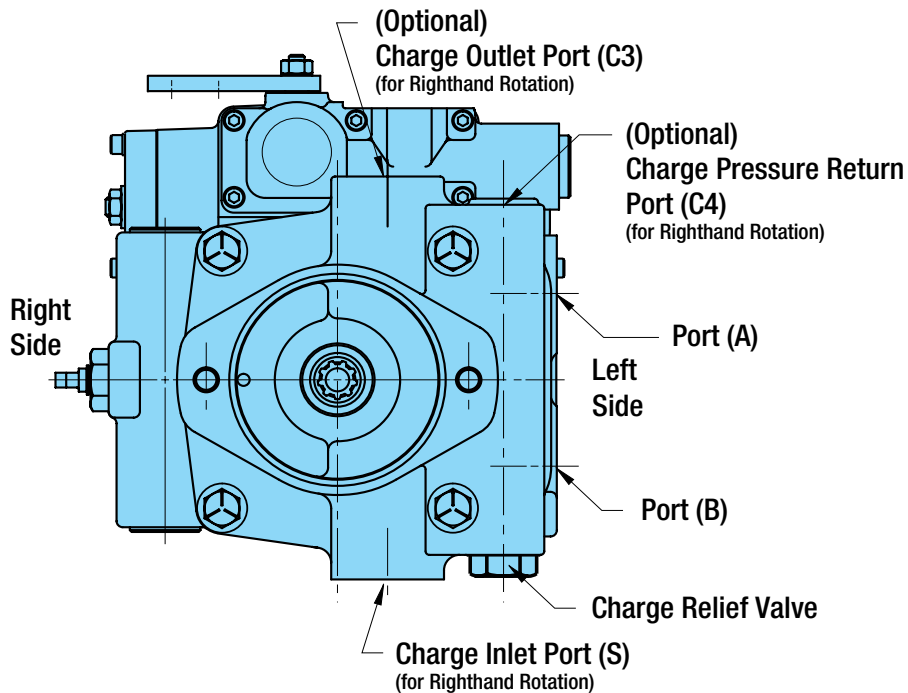

All left (CCW) or right (CW) directions given are viewed looking at the input shaft end of the pump.

# 72400

## Auxiliary and Drain Port Locations

### Code Position 10 and 11

(For dimensions, refer to Installation drawings.)

#### Drain Locations in Rear of Pumps

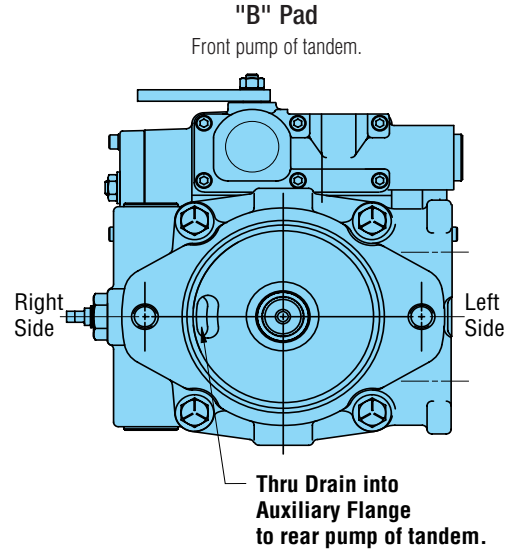
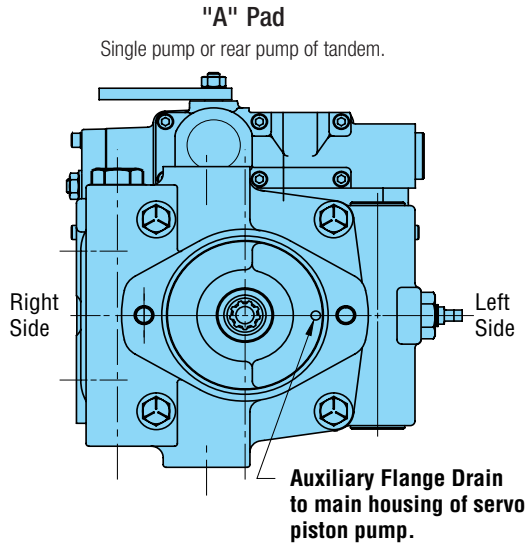

#### Side and Front of Pump

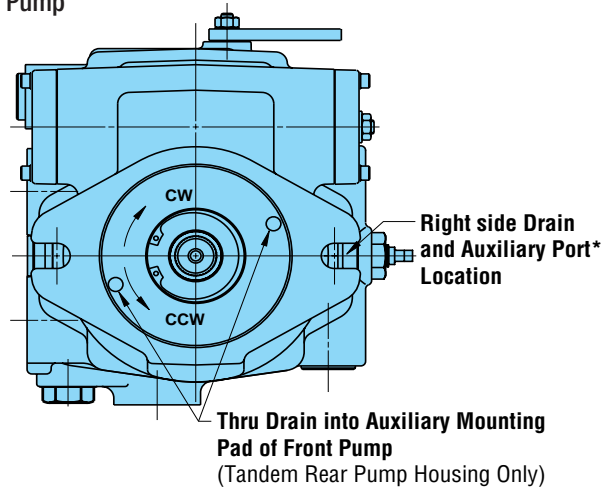
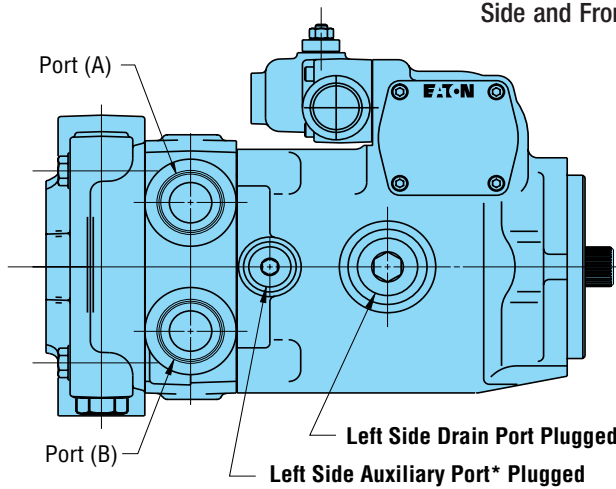

\*NOTE: Auxiliary port required in rear and front pump of tandem to provide charge flow and pressure to front pump.

All left (CCW) or right (CW) directions given are viewed looking at the input shaft end of the pump.

# 72400

## Main Ports and Relief Valve Location

### Code Position 12, 13, and 14

(For dimensions, refer to installation drawings.)  
 Charge pump position must stay in relationship to backplate as pictured below.

#### \*Righthand Rotation (CW)

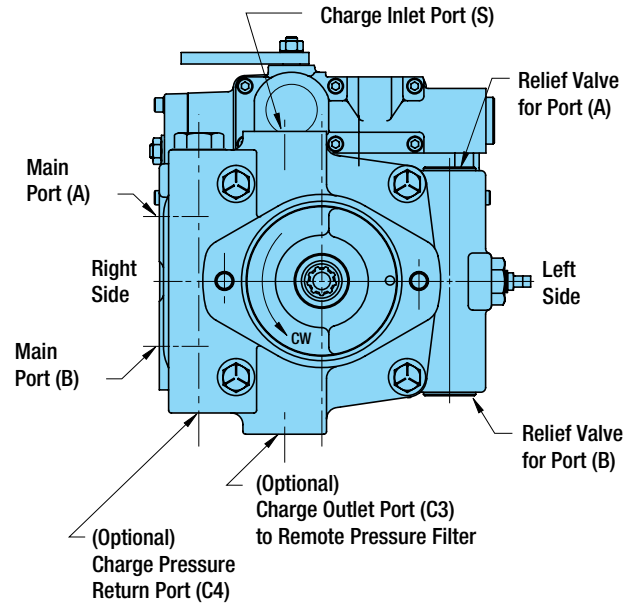
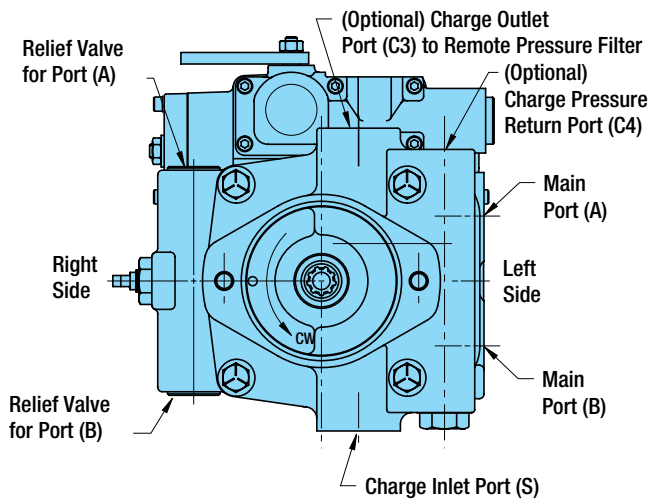

#### \*Lefthand Rotation (CCW)

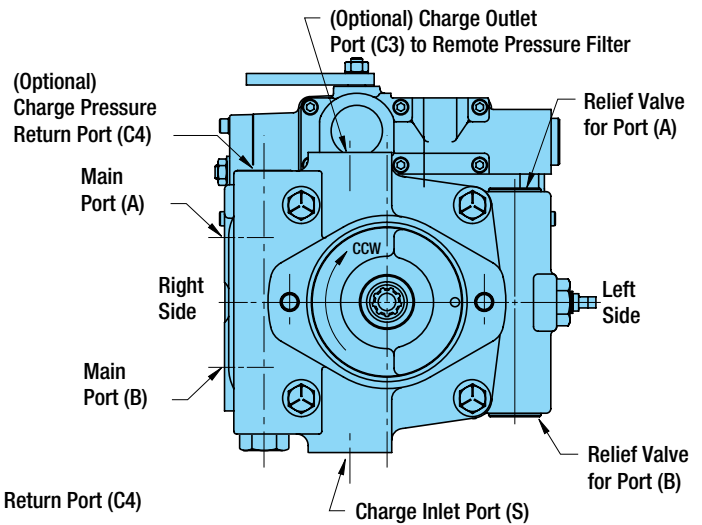
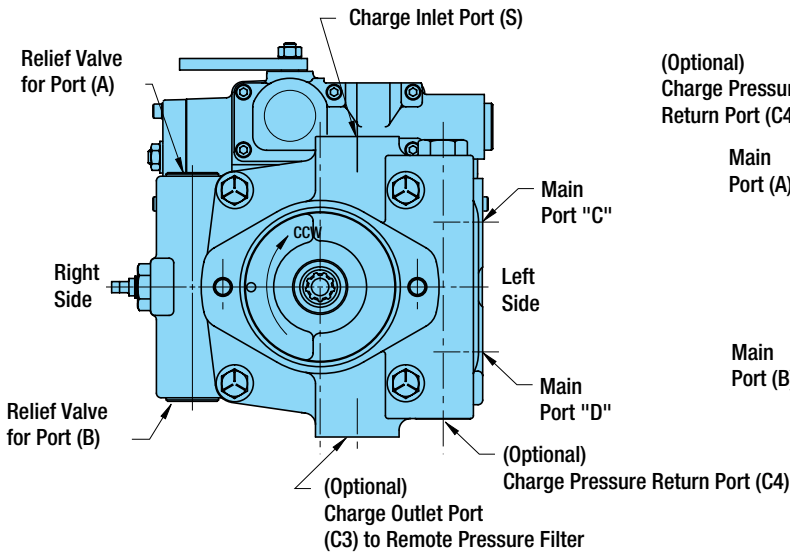

\*All left (CCW) or right (CW) directions given are viewed looking at the input shaft end of the pump.

# 72400

## Additional Functions

### Code Position 15

(For dimensions, refer to installation drawings.)

#### Bypass Valve

Opens the closed loop hydraulic circuit, allowing limited movement of a machine.

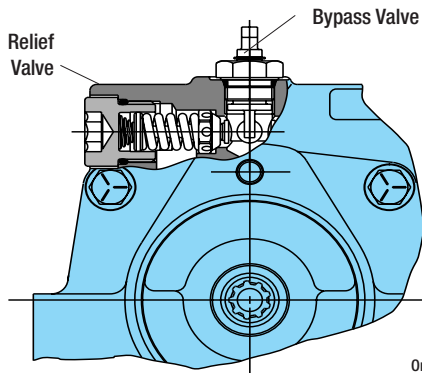

Order #72400-900 kit for Bypass Valve separately.

Dimensions are in millimeters [inches], unless otherwise specified.

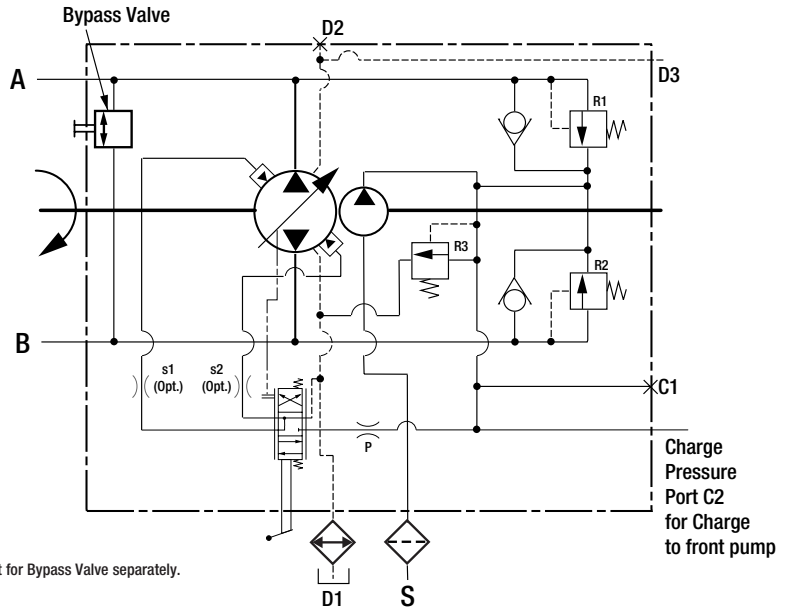

## Port Plate Control

### Code Position 16,17, and,18

The port plate is commonly used as a slave control that receives commands from other controls in the same system.

Minimum required control-pressure is 17 bar [250 PSI]

Righthand (CW) Input Rotation

- Pressure to Control Port 1
- Pressure to Control Port 2

Output Flow

- Port (B)
- Port (A)

Lefthand (CCW) Input Rotation

- Pressure to Control Port 1
- Pressure to Control Port 2

Output Flow

- Port (A)
- Port (B)

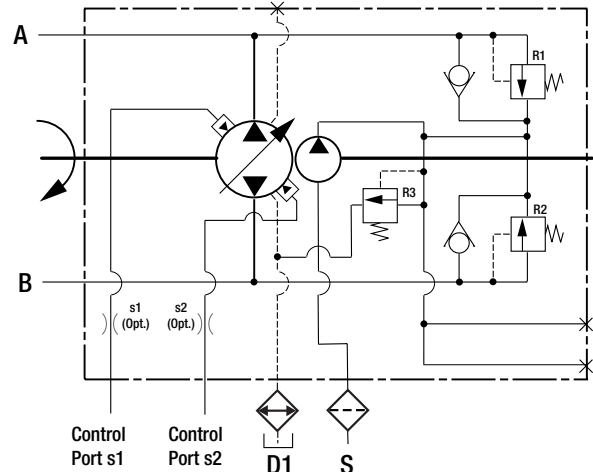

Model 72400

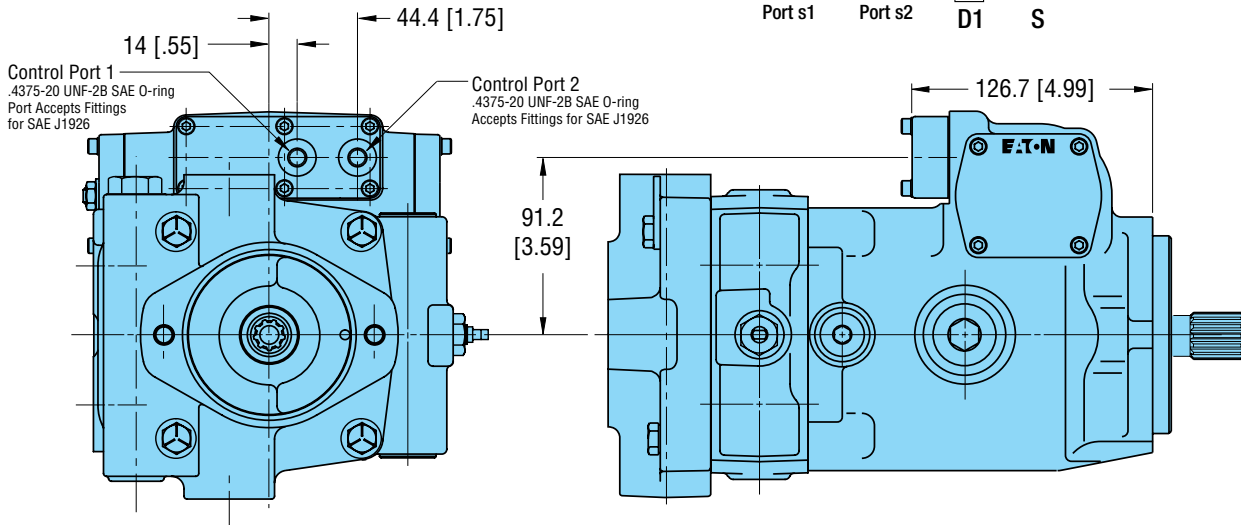



# 72400

## Manual Control

### Code Position 16,17, and,18

Dimensions are in millimeters [inches], unless otherwise specified.

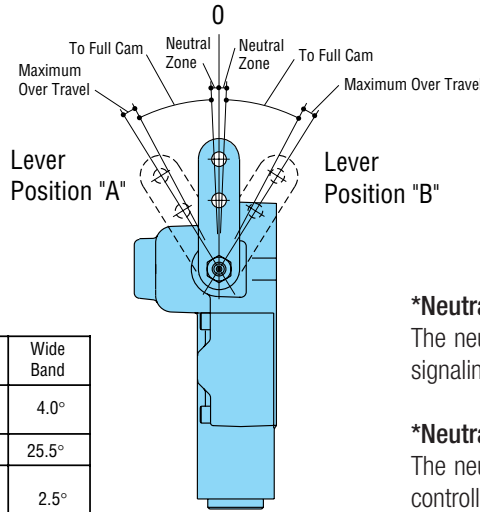

Control Lever Travel	Standard Band		Wide Band	
	Standard Band	Wide Band	Standard Band	Wide Band
Neutral Zone	2.5°	4.0°	2.5°	4.0°
Max. Displ.	25.5°	25.5°	25.5°	25.5°
Maximum Over Travel	4.0°	2.5°	4.0°	2.5°

#### \*Neutral Detent Feature

The neutral detent provides a positive, centered feeling to the handle, signaling the operator when the pump is in neutral position.

#### \*Neutral Lockout Feature

The neutral lockout switch consists of an electrical switch installed on the controller. This switch closes at the neutral position of the input lever and opens if lever is rotated either direction. The electronic "lockout" prevents the operator from starting any auxiliary functions unless the pump is in neutral position.

#### \*Destroke Valve Feature

The destroke valve provides an emergency return to neutral and must be energized in order for the pump to stroke. If at any time power is interrupted to the solenoid, the pump will destroke to neutral.

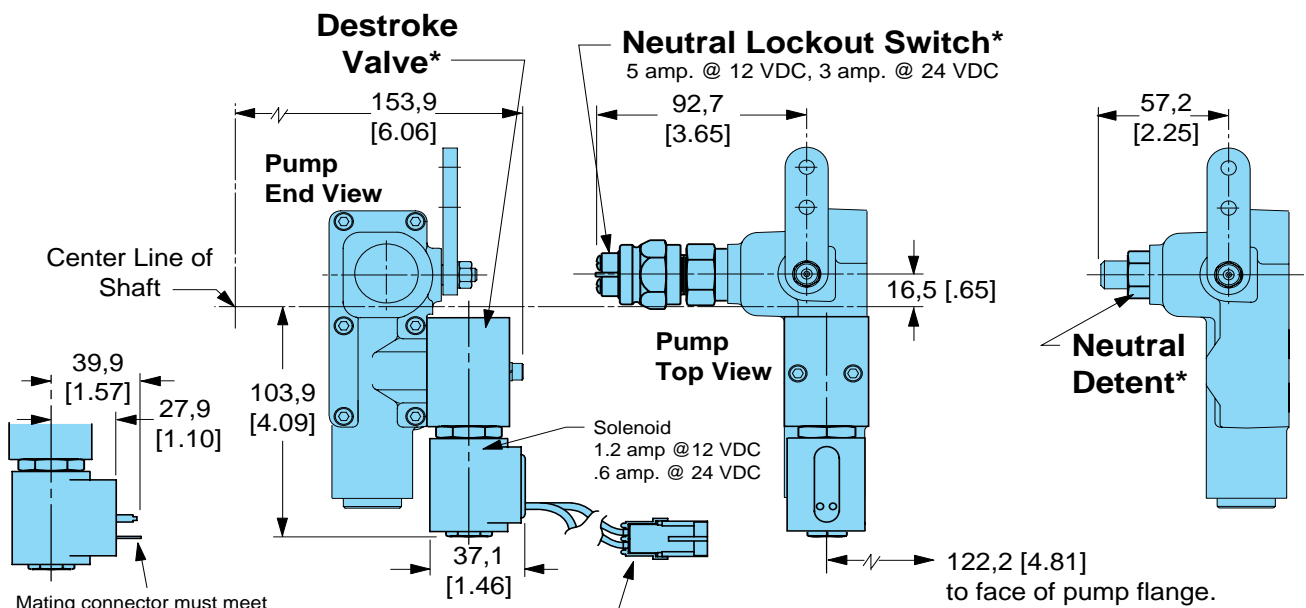

Mating connector must meet DIN 43650 specification such as Hirschman connector #931-236-100 with seal #731-531-002, or equivalent. Eaton P/N 103330-XXX

Weather Pack Connector provided on solenoid:

Body #12010973 (black)  
Terminal #12033674 (2)  
Seal #12010293 (2)

Weather Pack Mating Connector Required:

Body #12015792 (black)  
\*Terminal #12089188 (2)  
\*Seal #12010293 (2)

\*May vary due to wire gauge used.

# 72400

## Hydraulic Remote Control

Code Position 16,17

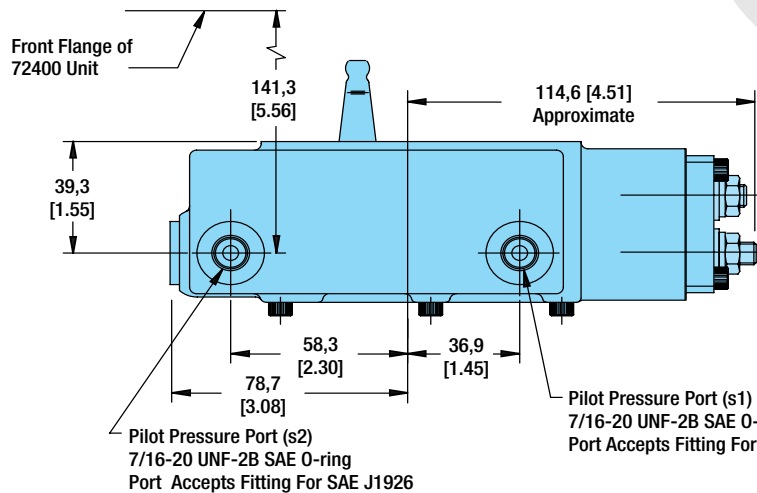
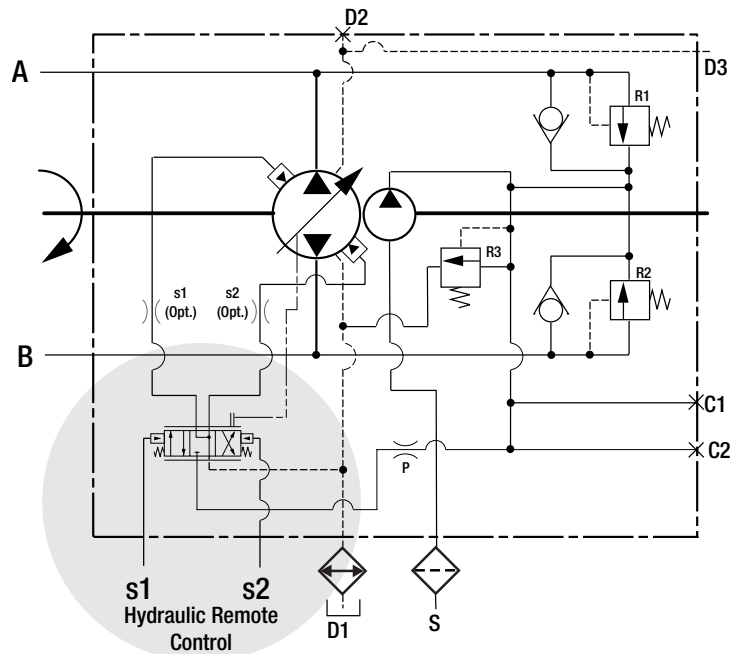
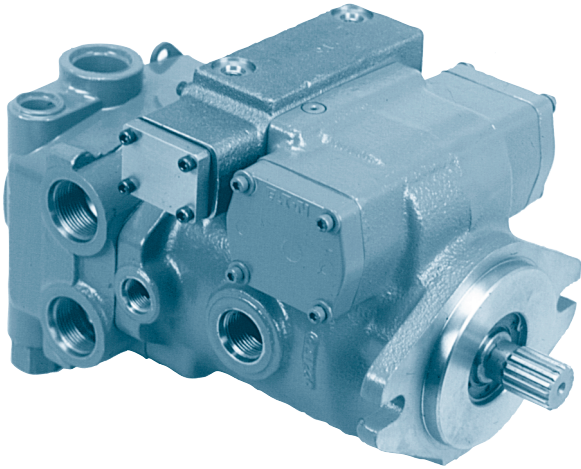

**NOTE**

- 1 Right Hand (Clockwise) Rotation  
 Pilot Press Port -1 Pressurized...flow From System Press Port -B  
 Pilot Press Port -2 Pressurized...flow From System Press Port -A
- Left Hand (Counter Clockwise) Rotation  
 Pilot Press Port -1 Pressurized...flow From System Press Port -A  
 Pilot Press Port -2 Pressurized...flow From System Press Port -B
- 2 Nominal Threshold Pressure ..... 5 bar [72.5 PSI]  
 Nominal Max Displacement Pressure ..... 15 bar [217.6 PSI]

Model 72400

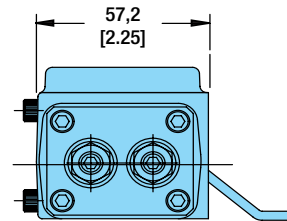
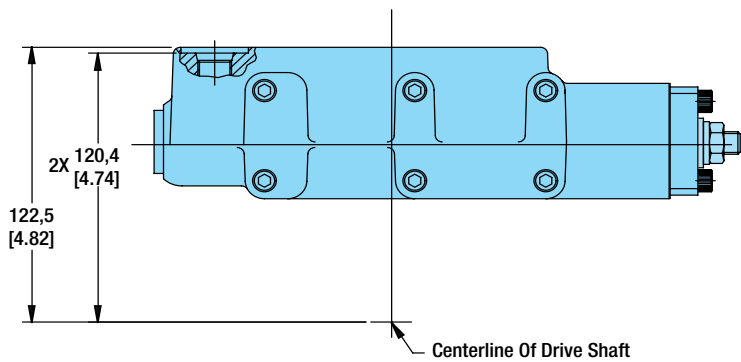

### Hydraulic Remote Control Conversion Kit

Order Part Number 72400-919

Includes: Control sub-assembly (1pc), Socket head cap screws (6 pc), Control housing gasket (1pc)

# 72400 Electronic Proportional Displacement Control

## Code Position 16,17

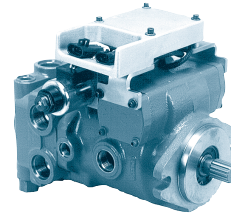

Model Code	Model Code Description	Typical Input Devices	Nominal Command Input Impedance of Electronics Module
	Command Input Signal		
EE	1 to 6 Vdc Potentiometric	Joysticks or Potentiometers with a resistance between 160 ohms and 50K ohms.	500K Ohms
EG	± 20 mA Current loop (4-20 mA)	Programmable Logic Controllers (PLC)	250 Ohms
EL	± 100 mA differential	Torque motor servo valve current drivers	28 Ohms
EC	12 Volts	Requires customer supplied electronics	
ED	24 Volts		

The Electronic Proportional (EP) displacement control is ideal for applications requiring electronic pump displacement control. The EP displacement control provides the flexibility of three command input choices. Control components include a proportional solenoid actuated valve assembly and an electronic solenoid driver module mounted on the pump. The control driver module converts a command input signal to a proportional current output to the proportional solenoids resulting in a proportional pump displacement.

The EP displacement control has been designed to withstand the rigors of off-highway equipment environmental conditions.

### EP Displacement Control Features

- Ease of installation
- Automotive style environmentally sealed Metri-Pack connectors
- Operates from 12 or 24 Vdc power supply
- External fuse (customer supplied):  
3A for 12 Vdc system, 1A for 24 Vdc system
- Three choices for command input signal
- Operating temperature range -40° C to +85° C
- Control driver module encapsulated for environmental protection
- Closed loop current control compensates for resistance change of the proportional solenoids due to temperature variations
- Return to neutral for loss of power, or loss of command input signal
- Mechanical feedback of swashplate position for closed loop control
- External neutral adjustment
- Manual override capability
- Control drive module qualification per SAE J1455, SAE J1113, CISPR 25

Control Driver Module Qualification  
(Contact Eaton for Specific Levels)

- SAE J1455 - Recommended Environmental Practices for Electronic Equipment Design

Humidity/Temperature Extreme Cycling  
Salt Spray  
Splash & Immersion  
Steam Cleaning/High Pressure Wash  
Vibration  
Mechanical Shock  
Temperature Cycling  
Load Dump Transients  
Inductive Load Switching Transients

- SAE J1113 - Electromagnetic Susceptibility Measurement Procedures for Vehicle Components

EMI/EMC - Conducted & Radiated Immunity

- CISPR 25 - International Electrotechnical Commission "Limits and Methods of Measurement of Radio Disturbance Characteristics for the Protection of Receivers used on Board Vehicles".

EMI /EMC - Conducted & Radiated Emissions

# 72400

## Electronic Proportional Displacement Control

Code Position 16,17 (EE, EG, EL) Cont.

### Interface Schematic

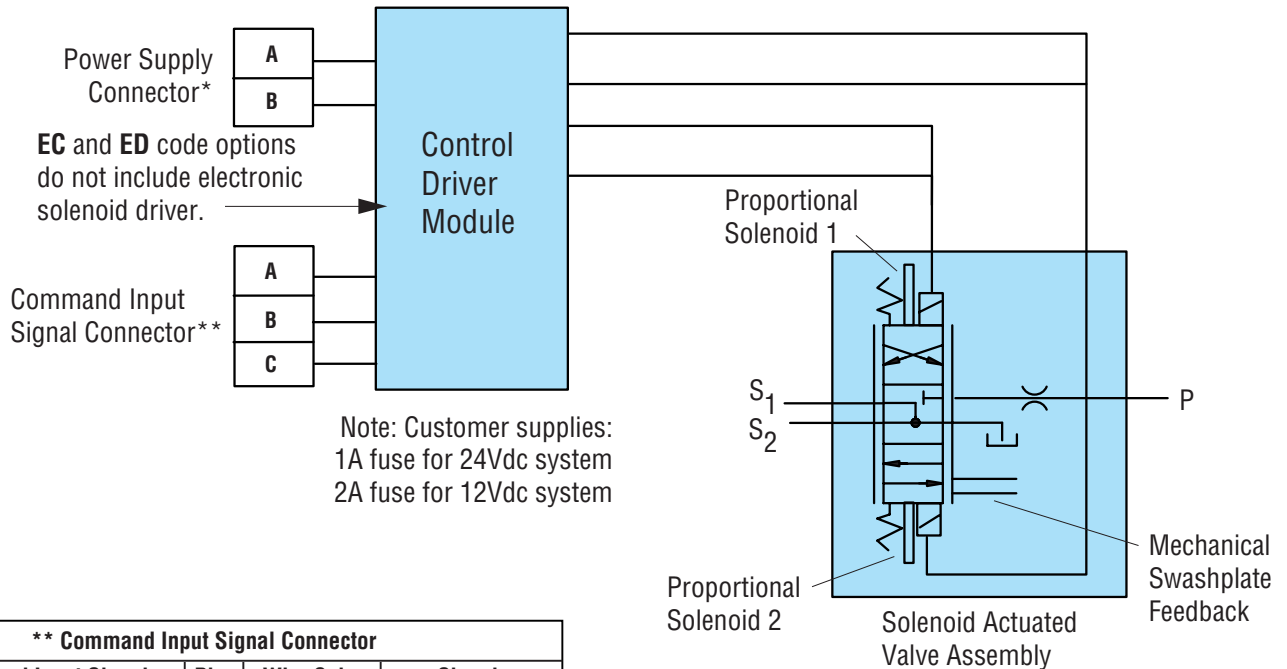

** Command Input Signal Connector			
Command Input Signal	Pins	Wire Color	Signal
1 to 6 Vdc Potentiometric	A	Black	Ref Low - 1 Vdc
	B	Green	Command (wiper)
	C	Red	Ref Hi - 6 Vdc
± 20 mA Current loop (4-20 mA)	A	Orange	Loop Return
	B	White	Loop In
	C	No Connection Required*	
± 100 mA differential	A	Blue	Loop Return
	B	White	Loop In
	C	No Connection Required*	

\* Mating connector kit 990762-000 contains plug to be used to seal mating end connector.

Model 72400

### Solenoid Actuated Valve Assembly

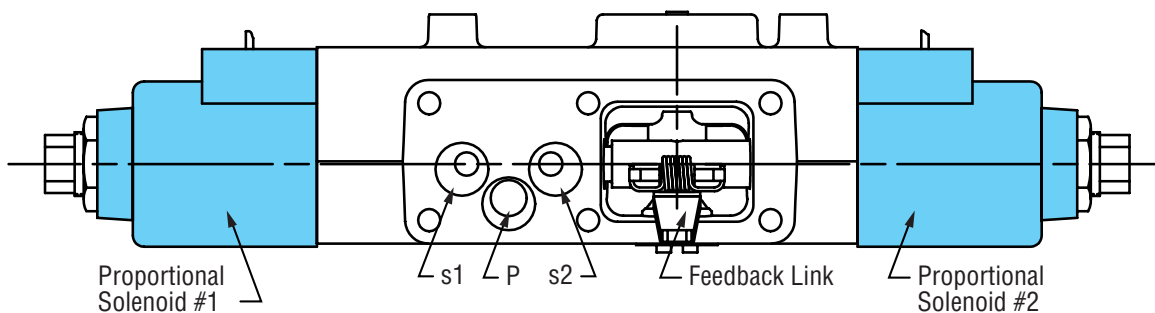

# 72400

## Electronic Proportional Displacement Control

### Code Position 16,17

(EE, EG, EL) Cont.

Mating Connector Kit: Eaton P/N 990762-000\*

Recommended: Wire Size 16-18 AWG,  
Cable Dia. 2.03 - 2.80 mm

Kit includes:

Mating Connectors for 2-pin Power Supply Connector,  
3-pin Command Input Signal Connector

\*Delphi/Packard  
Mating Connector Part Numbers:  
Recommended: Wire Size 16-18 AWG,  
Cable Dia. 2.03 - 2.80 mm  
Reference Source: Pioneer-Standard Electronics 1-800  
257-6613

1) Power Supply 2-pin connector  
Connector P/N 1205 2641  
Terminal P/N 1204 8074  
TPA P/N 1205 2634  
Cable Seal 1204 8086

2) Command Input Signal 3 Pin Connector  
Connector P/N 1211 0293  
Terminal P/N 1204 8074  
TPA P/N 1205 2845  
Cable Seal 1204 8086

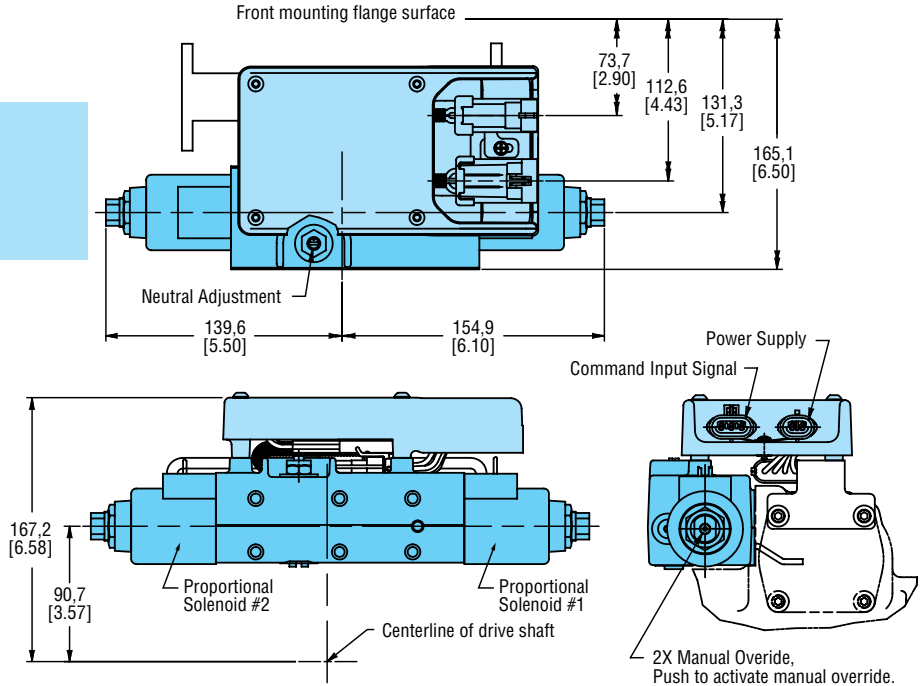

**Note:** In order to assure the most reliable installation and operation of any electronic control, proper installation methods should be followed with respect to interconnection wiring harness, command signal devices, fusing, and input power switching. Proper care should be taken to prevent damage to all electrical and electronic components due to abrasion, moving objects, heat, moisture or other environmental hazards. For safety critical applications, Eaton recommends that a switch be installed in line with (+ Battery) power to the module so that power may quickly be disconnected in case of emergency. A 2 ampere slow blow fuse should always be installed in the + battery line. It is recommended that during initial start-up and checkout, the machine be placed on jack stands to prevent inadvertent movement of the machine.

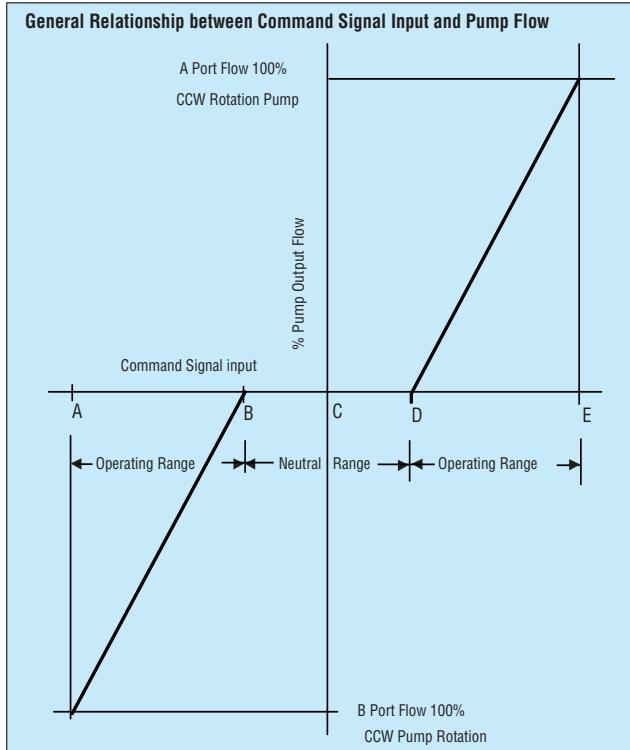

Command Input Signal	A (max)	B (min)	C	D (min)	E (max)
1 to 6 Vdc	1.5 Vdc	3.3 Vdc	3.5 Vdc	3.7 Vdc	5.5 Vdc
4-20 mA*	-20 mA	-4.5 mA	0 mA	+4.5 mA	+20 mA
±100 mA	-100 mA	-7.5 mA	0 mA	+7.5 mA	+100 mA

\*Note: The +20 mA command input signal configuration operates the pumps in one direction. The customer has to change the polarity on the -20 mA signal to operate the pump in the opposite direction.

# 72400

## Solenoid Operated Control

### Code Position 16,17

Schematic Code SA

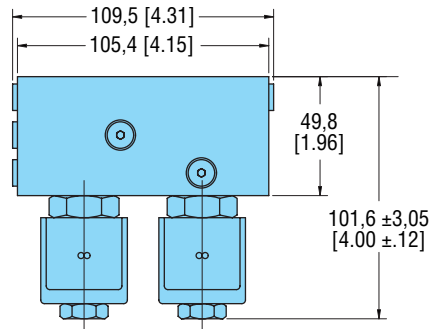
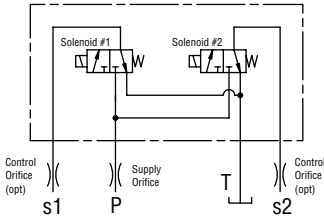

Code SA  
Drawing Shown.

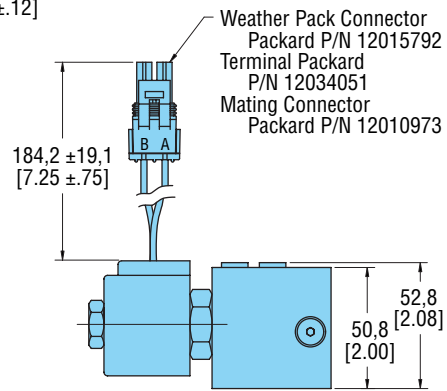
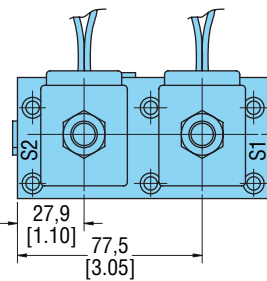

Note:  
Solenoid Coil Specifications  
Voltage: 12 Vdc  
Watts: 20 (Nominal)

Weather Pack Connector  
Packard P/N 12015792  
Terminal Packard  
P/N 12034051  
Mating Connector  
Packard P/N 12010973

Schematic Code SB

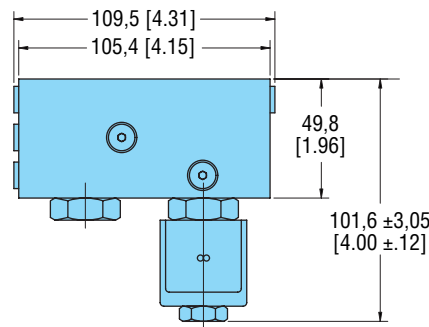
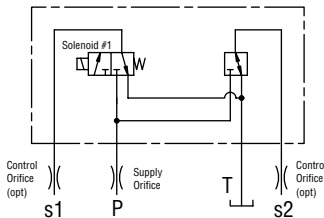

Code SB  
Drawing Shown.  
The SC Code has Solenoid  
in place of plug and plug  
in place of Solenoid.

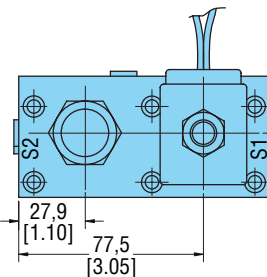

Note:  
Solenoid Coil Specifications  
Voltage: 12 Vdc  
Watts: 20 (Nominal)

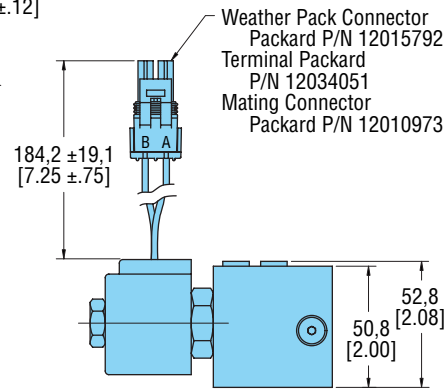

Weather Pack Connector  
Packard P/N 12015792  
Terminal Packard  
P/N 12034051  
Mating Connector  
Packard P/N 12010973

Schematic Code SC

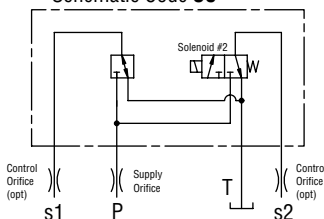

# 72400

## Adjustable Displacement Limiter

### Code Position 24, 25 and Selection BB

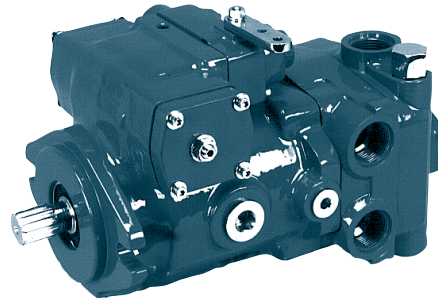

- Externally Adjustable Displacement
- Settings are Maximum Displacement of the Pump to Zero
- Independent Adjustment for Both Main Ports
- Field Adjustable
- Available in Kit Form (see page 62)

All factory units shipped with adjustable stops are set at maximum pump displacement.  
See re-adjustment instructions below.

### To Calculate Displacement Required

The displacement required divided by displacement of one turn of set screw equals the number of turns of set screw to obtain displacement.

Example for 3.00 in<sup>3</sup>/r re-adjustment:  
 $2.0 \text{ in}^3/\text{r} \div .2854 \text{ in}^3/\text{r} =$   
 7 turns of set screw

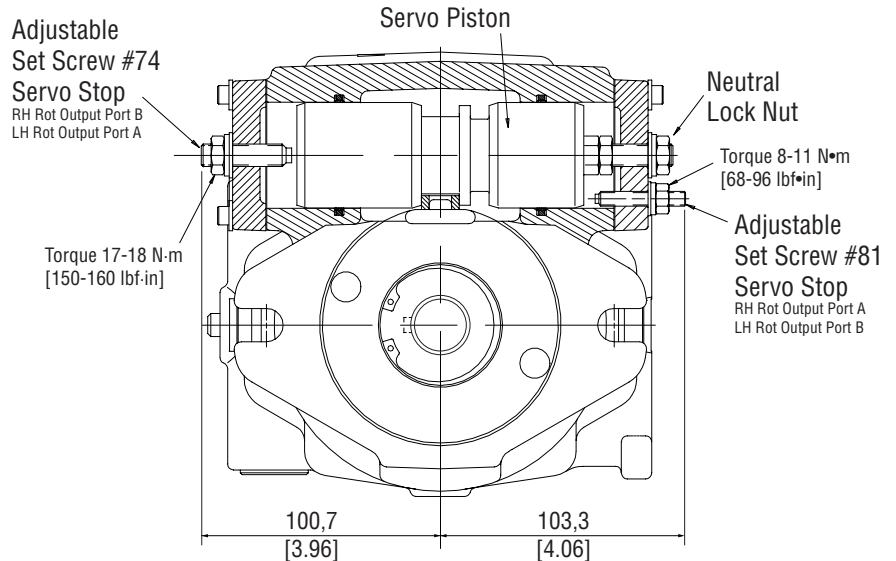

Displacement per Turn		
2.48 in <sup>3</sup> /r Pump Displacement @ Full Cam		
Turns of Set Screw	Item #81 Stop	Item #74 Stop
1	.2359 in <sup>3</sup> /r	.2022 in <sup>3</sup> /r
2	.47 in <sup>3</sup> /r	.40 in <sup>3</sup> /r
3	.71 in <sup>3</sup> /r	.61 in <sup>3</sup> /r
4	.94 in <sup>3</sup> /r	.81 in <sup>3</sup> /r
5	1.18 in <sup>3</sup> /r	1.01 in <sup>3</sup> /r
6	1.42 in <sup>3</sup> /r	1.21 in <sup>3</sup> /r
7	1.65 in <sup>3</sup> /r	1.42 in <sup>3</sup> /r
8	1.89 in <sup>3</sup> /r	1.62 in <sup>3</sup> /r
9	2.12 in <sup>3</sup> /r	1.82 in <sup>3</sup> /r
10	2.36 in <sup>3</sup> /r	2.02 in <sup>3</sup> /r
10.5	<b>2.48 in<sup>3</sup>/r</b>	2.13 in <sup>3</sup> /r
11	N/A	2.22 in <sup>3</sup> /r
12	N/A	2.43 in <sup>3</sup> /r
12.3	N/A	<b>2.48 in<sup>3</sup>/r</b>

Displacement per Turn		
2.48 in <sup>3</sup> /r Pump Displacement @ Full Cam		
Turns of Set Screw	Item #81 Stop	Item #74 Stop
1	.2359 in <sup>3</sup> /r	.2022 in <sup>3</sup> /r
2	.47 in <sup>3</sup> /r	.40 in <sup>3</sup> /r
3	.71 in <sup>3</sup> /r	.61 in <sup>3</sup> /r
4	.94 in <sup>3</sup> /r	.81 in <sup>3</sup> /r
5	1.18 in <sup>3</sup> /r	1.01 in <sup>3</sup> /r
6	1.42 in <sup>3</sup> /r	1.21 in <sup>3</sup> /r
7	1.65 in <sup>3</sup> /r	1.42 in <sup>3</sup> /r
8	1.89 in <sup>3</sup> /r	1.62 in <sup>3</sup> /r
9	2.12 in <sup>3</sup> /r	1.82 in <sup>3</sup> /r
10	2.36 in <sup>3</sup> /r	2.02 in <sup>3</sup> /r
10.5	<b>2.48 in<sup>3</sup>/r</b>	2.13 in <sup>3</sup> /r
11	N/A	2.22 in <sup>3</sup> /r
12	N/A	2.43 in <sup>3</sup> /r
12.3	N/A	<b>2.48 in<sup>3</sup>/r</b>

### To Re-Adjust Displacement

- 1 Loosen nut on adjustable set screw #81 servo stop. Screw stop in until it touches the servo piston. Back the screw out (number of turns required) to obtain the flow required. Refer to chart for displacements. Lock adjustment with nut. Torque nut 8 to 11 N·m [68 to 96 lbf·in].
- 2 Loosen nut on adjustable set screw #74 servo stop. Screw stop in until it touches the servo piston. Back the screw out (number of turns required) to obtain the flow required. Refer to chart for displacements. Lock adjustment in place with nut. Torque nut 17 to 18 N·m [150 to 160 lbf·in].

Metric Conversion: Displacement in<sup>3</sup>/r X 16.387 = cm<sup>3</sup>/r

# 72400 Adjustable Displacement Limiter Kits

Field Installed Kits

One side ..... Kit #72400-938

Two sides ..... Kit #72400-940

## Disassembly

- 1 Remove the four cap screws (Item #7) and washers (Item #61) retaining the existing cover plate (Item #11) opposite neutral set screw.
- 2 After removing existing cover plate (Item #11) and cover gasket, measure the distance from the servo piston to the surface of housing for reference for neutral setting.
- 3 Remove neutral setting nut (Item #2).
- 4 Remove the four cap screws retaining the existing cover plate (Item #17).
- 5 The cover plate (Item #17) is screwed onto the servo piston bolt. When removing the cover plate, count the amount of turns it takes to remove cover for reassembly. Also remove existing gasket (Item #12).

## Installing Servo Stops

- 1 Place new gasket (Item #12) onto the housing on the neutral setting screw side of the servo piston. Hold in position with a small amount of petroleum jelly.
- 2 Screw new cover plate (Item #17) onto servo piston bolt the same number of turns as it took to remove it. Install the four cap screws (Item #7) and washers (Item #61) to retain cover plate. Torque 4,5 to 5,4 N-m [40 to 48 lbf-in].
- 3 Install seal washer (Item #6), washer (Item #60) and jam nut (Item #2). Torque nut 17 to 18 N-m [150 to 160 lbf-in]. At this time, check the distance from the servo piston to housing surface on opposite side. It should be the same as previously measured at disassembly. If not the same, loosen jam nut and with a hex key wrench, adjust and re-torque nut.
- 4 Install new cover plate (Item #11) and retain with four cap screws (Item #7) and washers (Item #61). Torque 4,5 to 5,4 N-m [40 to 48 lbf-in].
- 5 Insert adjustable servo stop set screw (Item #81) in until it touches the servo piston. Back the screw out to obtain the flow required. Refer to chart for displacements. Lock adjustment into place with seal washer (Item #83), washer (Item #82), and jam nut (Item #80). Torque nut 8 to 11 N-m [68 to 96 lbf-in].
- 6 Insert adjustable servo stop set screw (Item #74) in until it touches the servo piston. Back the screw out to obtain the flow required. Refer to chart for displacements. Lock adjustment into place with seal washer (Item #6), washer (Item #60), and jam nut (Item #2). Torque nut 17 to 18 N-m [150 to 160 lbf-in].

Adjustable Servo Stop Kit Parts			Kit #72400-938	Kit #72400-940
Item #	Part Number	Description	Qty.	Qty.
2	16024-6	Jam Nut	1	2
6	16254-6	Seal Washer	1	2
11	72400-651	Cover Plate	1	1
12	72400-621	Cover Gasket	1	2
17	72400-771	Cover Plate		1
60	16254-26	Washer	1	2
74	16139-624	Set Screw	1	1
80	16022-4	Jam Nut		1
81	16139-424	Set Screw		1
82	16254-24	Washer		1
83	16254-4	Seal Washer		1

Model 72400

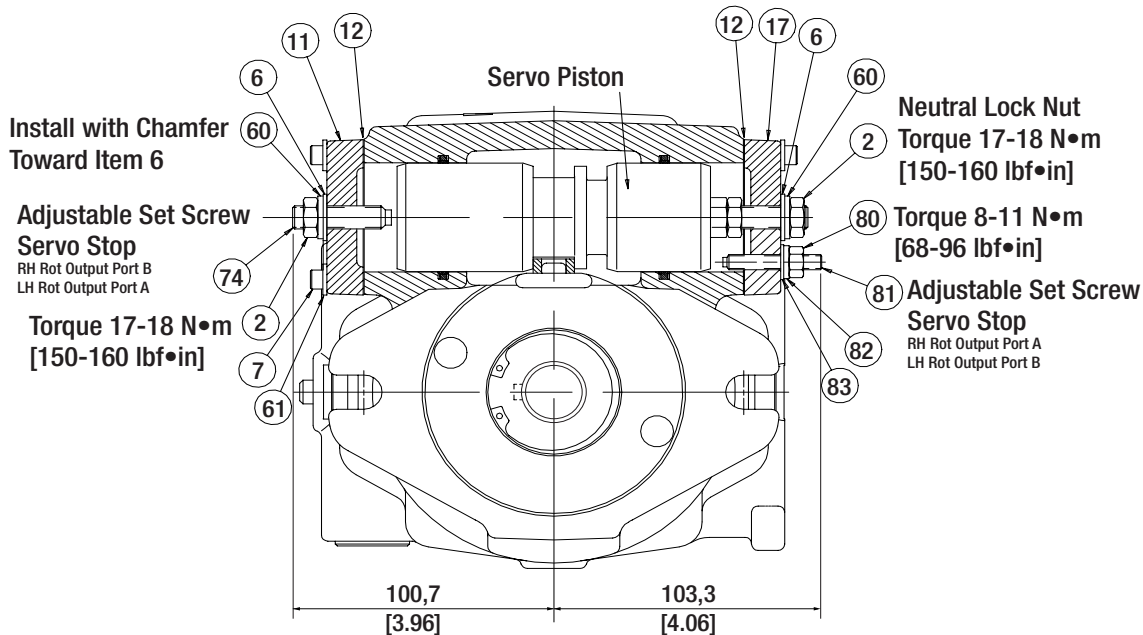



# 72400

## Supply and Control Orifice

Code Position 19 and 20

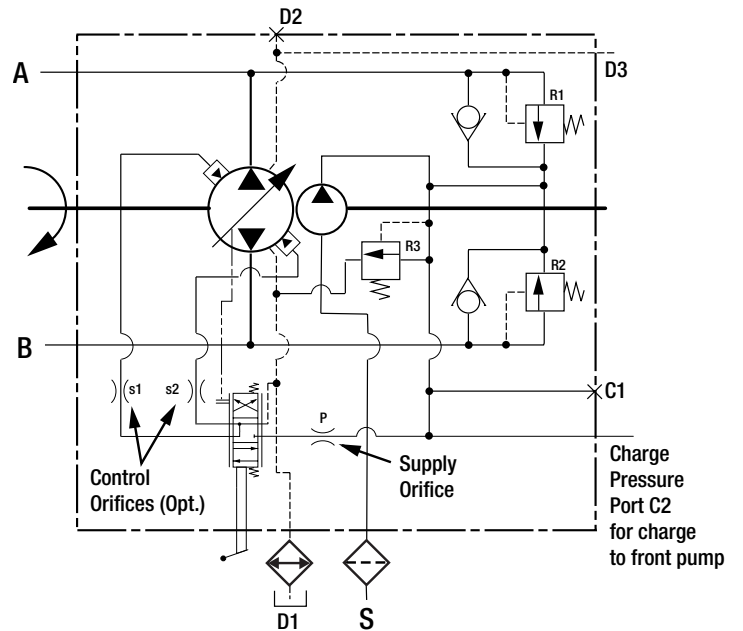
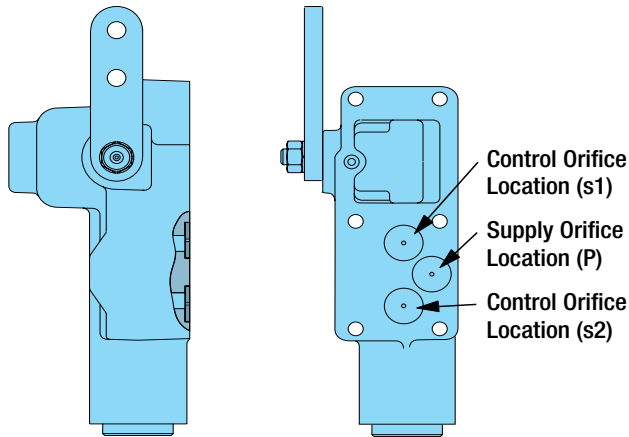

### Calculated Time from Neutral to Full Stroke (seconds)

Supply Orifice Size mm [in]	Control Orifice Size, mm [in]							
	0,71 [0.028]	0,81 [0.032]	0,91 [0.036]	1,02 [0.040]	1,12 [0.044]	1,32 [0.052]	1,45 [0.057]	None
0,71 [0.028]	1.245	1.148	1.085	1.043	1.015	0.983	0.972	0.946
0,81 [0.032]	1.199	1.089	1.013	0.961	0.925	0.881	0.866	0.828
0,91 [0.036]	1.173	1.053	0.968	0.907	0.863	0.808	0.788	0.736
1,02 [0.040]	1.157	1.031	0.939	0.871	0.821	0.756	0.731	0.662
1,12 [0.044]	1.147	1.017	0.920	0.847	0.792	0.718	0.688	0.602
1,32 [0.052]	1.136	1.001	0.899	0.820	0.758	0.670	0.633	0.510
1,45 [0.057]	1.133	0.996	0.892	0.810	0.745	0.652	0.611	0.465
1,65 [0.065]	1.129	0.991	0.885	0.801	0.734	0.634	0.589	0.408
1,85 [0.073]	1.128	0.988	0.881	0.796	0.727	0.624	0.576	0.364
None	1.125	0.984	0.875	0.787	0.716	0.606	0.553	0.138

**Note:** Proper orifice selection must be determined by actual testing.

# Component Selection

The long service life of Eaton hydrostatic transmissions is largely dependent on the proper selection and installation of the components necessary for transmission operation.

The following components are necessary for transmission operation:

1. Variable Displacement Pump
2. Fixed or Variable Displacement Motor
3. Reservoir
4. Filter
5. Charge Pump Inlet Line
6. Pump and Motor Case Drain Lines
7. High Pressure Lines
8. Heat Exchanger
9. Heat Exchanger Bypass Valve
10. Reservoir Return Line

## 1. Variable Displacement Pump

Eaton hydrostatic variable displacement pumps are an axial piston design. They are equipped with standard SAE mounts, shafts and port connections.

## 2. Fixed or Variable Displacement Motor

Eaton hydrostatic motors are an axial piston design. They are equipped with standard SAE mounts, shafts and port connections.

## 3. Reservoir

The reservoir is an important part of the hydrostatic transmission system. It should provide adequate oil storage and allow easy oil maintenance.

The reservoir must hold enough oil to provide a continuous oil supply to the charge pump inlet. It must also have enough room for the hydraulic oil to expand as the system warms up. Consider charge pump flow when sizing the reservoir: One half (.5) minute times (X) the maximum charge pump flow should be the minimum oil volume in the reservoir. Maintaining this oil volume will give the oil a minimum of thirty (30) seconds in the reservoir. This will allow any entrained air to escape and contamination to settle out of the oil.

To allow for oil expansion, the reservoir's total volume should be at least six tenths (.6) minute times (X) the maximum charge pump flow.

The reservoir's internal structure should cut down turbulence and prevent oil aeration.

The line returning flow to the reservoir should be fitted with a diffuser to slow the incoming oil to 1 to 1.2 meters [3-4 feet] per second to help reduce turbulence. The return flow line should also

be positioned so that returning oil enters the reservoir below the liquid surface. This will help reduce aeration and foaming of the oil.

The reservoir should have baffles between the return line and suction line. Baffles prevent return flow from immediately reentering the pump.

A sixty mesh screen placed across the suction chamber of the reservoir will act as a bubble separator. The screen should be placed at a 30° angle to the horizon.

The entrance to the suction line should be located well below the fluid surface so there is no chance of air being drawn into the charge pump inlet. However, the suction line entrance should not be located on the bottom of the reservoir where there may be a buildup of sediment. The suction line entrance should be flared and covered with a screen.

The reservoir should be easily accessible. The fill port should be designed to minimize the possibility of contamination during filling and to help prevent over filling. There should be a drain plug at the lowest point of the reservoir and it should also have a clean-out and inspection cover so the reservoir can be thoroughly cleaned after prolonged use. A vented reservoir should have a breather cap with a micronic filter.

Sealed reservoirs must be used at altitudes above 2500 feet. These reservoirs should be fitted with a two-way micronic filter pressure cap to allow for fluid expansion and contraction.

In both cases the caps must be designed to prevent water from entering the reservoir during bad weather or machine washing.

A hydrostatic transmission with a well designed reservoir will run quieter, stay cleaner and last longer.

## 4. Filter

A filter must be used to keep the hydraulic fluid clean. Either a suction filter or a pressure side filter may be used. The filter must be a no-bypass type. System oil particle levels should not exceed ISO 18/13. Refer to Eaton Hydraulic Fluid Recommendations.

Recommended beta ratios for each filter type are listed below:

Suction Filter  $\beta_{10} = 1.5$  to 2.0

Pressure Side Filter  $\beta_{10} = 10$  to 20

When a suction filter is used, its flow capacity must be large enough to prevent an excessive pressure drop between the reservoir and charge pump inlet. The pressure at the charge pump inlet port must not be less than 0,80 bar absolute [6 in. Hg.] at normal continuous operating temperatures.

## 5. Charge Pump Inlet Line

The inlet line to the charge pump should be large enough to keep the pressure drop between the reservoir and charge pump inlet within the limits described in the filter section. Fittings will increase the pressure drop, so their number should be kept to a

minimum. It is best to keep fluid velocities below 1,25 meters [4 feet] per second.

Fluid and temperature compatibility must be considered when selecting the inlet line.

### 6. Pump and Motor Case Drain

The case drain lines should be large enough to limit the pump and motor case pressures (Medium Duty to 2 bar [25 PSI]) at normal operating temperatures. Fluid and temperature compatibility must also be considered when selecting the case drain lines.

### 7. High Pressure Lines

The high pressure lines that connect the pump and motor must be able to withstand the pressures generated in the high pressure loop.

### 8. Heat Exchanger

Use of a heat exchanger is dependent on the transmission's duty cycle and on machine layout. The normal continuous operating fluid temperature measured in the pump and motor cases should not exceed 80½C [180½F] for most hydraulic fluids. The maximum fluid temperature should not exceed 107½C [225½F].

The heat exchanger should be sized to dissipate 25% of the maximum input power available to the transmission. It must also be sized to prevent the case pressures in the pump and motor from getting too high. Medium duty case pressure up to 2 bar [25 psi], at normal operating temperatures, are acceptable.

### 9. Heat Exchanger Bypass Valve

The heat exchanger bypass valve is a pressure and/or temperature valve in parallel with the heat exchanger. Its purpose is to prevent case pressures from getting too high. The heat exchanger bypass valve opens when the oil is thick, especially during cold starts.

### 10. Reservoir Return Line

The same general requirements that apply to case drain lines apply to the reservoir return line.

## Installation Requirements

The mounting orientation of pumps and motors is unrestricted provided the case drain of the pump and motor remain full. Position the case drain such that it assures an oil level at or above unit center line at start-up. The case drain line that carries the flow leaving the pump or motor should be connected to the highest

drain port on each of the units. This assures that the pump and motor cases remain full.

The combined torque required to turn two or more pumps must not exceed the torque rating of the input drive shaft of the front piston pump.

Installer to provide centering and a secure neutral for pump swashplate control shaft.

An external support is recommended for all tandems.

### Open Loop Circuits

Eaton pumps and motors may be used in open loop circuits under certain operating conditions. Consult your Eaton representative for details.

# Hydraulic Fluid Recommendations

## Introduction

The ability of Eaton hydrostatic components to provide the desired performance and life expectancy depends largely on the fluid used. The purpose of this document is to provide readers with the knowledge required to select the appropriate fluids for use in systems that employ Eaton hydrostatic components.

One of the most important characteristics to consider when choosing a fluid to be used in a hydraulic system is viscosity. Viscosity choice is always a compromise; the fluid must be thin enough to flow easily but thick enough to seal and maintain a lubricating film between bearing and sealing surfaces. Viscosity requirements for Eaton's Heavy Duty Hydrostatic product line are specified later in this document.

## Viscosity and Temperature

Fluid temperature affects viscosity. In general, as the fluid warms it gets thinner and its viscosity decreases. The opposite is true when fluid cools. When choosing a fluid, it is important to consider the start-up and operating temperatures of the hydrostatic system. Generally, the fluid is thick when the hydraulic system is started. With movement, the fluid warms to a point where the cooling system begins to operate. From then on, the fluid is maintained at the temperature for which the hydrostatic system was designed. In actual applications this sequence varies; hydrostatic systems are used in many environments from very cold to very hot. Cooling systems also vary from very elaborate to very simple, so ambient temperature may affect operating temperature. Equipment manufacturers who use Eaton hydrostatic components in their products should anticipate temperature in their designs and make the appropriate fluid recommendations to their customers.

In general, an ISO viscosity grade 68 fluid is recommended for operation in cold to moderate climates. An ISO viscosity grade 100 fluid is recommended for operation in moderate to hot climates.

## Cleanliness

Cleanliness of the fluid in a hydrostatic system is extremely important. Eaton recommends that the fluid used in its hydrostatic components be maintained at ISO Cleanliness Code 18/13 per

SAE J1165. This code allows a maximum of 2500 particles per milliliter greater than 5  $\mu\text{m}$  and a maximum of 80 particles per milliliter greater than 15  $\mu\text{m}$ . When components with different cleanliness requirements are used in the same system, the cleanest standard should be applied. OEM's and distributors who use Eaton hydrostatic components in their products should provide for these requirements in their designs. A reputable filter supplier can supply filter information.

## Fluid Maintenance

Maintaining correct fluid viscosity and cleanliness level is essential for all hydrostatic systems. Since Eaton hydrostatic components are used in a wide variety of applications it is impossible for Eaton to publish a fluid maintenance schedule that would cover every situation. Field testing and monitoring are the only ways to get accurate measurements of system cleanliness. OEM's and distributors who use Eaton hydrostatic components should test and establish fluid maintenance schedules for their products. These maintenance schedules should be designed to meet the viscosity and cleanliness requirements laid out in this document.

## Fluid Selection

Premium grade petroleum based hydraulic fluids will provide the best performance in Eaton hydrostatic components. These fluids typically contain additives that are beneficial to hydrostatic systems. Eaton recommends fluids that contain anti-wear agents, rust inhibitors, anti-foaming agents, and oxidation inhibitors. Premium grade petroleum based hydraulic fluids carry an ISO VG rating.

# Hydraulic Fluid Recommendations

## Viscosity Requirements

Product Line	* Minimum	Optimum Range	Maximum	ISO Cleanliness Requirements	Comments
Heavy Duty Piston Pumps and Motors	45 SUS [6 cSt]	60 - 180 SUS [10 - 39 cSt]	10,000 SUS [2158 cSt]	18/13	
Medium Duty Piston Pumps and Motors Charged Systems	45 SUS [6 cSt]	60 - 180 SUS [10 - 39 cSt]	10,000 SUS [2158 cSt]	18/13	
Medium Duty Piston Pumps and Motors Non-charged Systems	60 SUS [10 cSt]	60 - 180 SUS [10 - 39 cSt]	2,000 SUS [432 cSt]	18/13	
Light Duty Transaxles, Transmissions, Pumps and Series 1150 Transaxles	60 SUS [10 cSt]	80 - 180 SUS [16 - 39 cSt]	10,000 SUS [2158 cSt]	18/13	Automotive multi-viscosity oils and ATF are not recommended
Series 2030 Motor Axles	70 SUS [13 cSt]	100 - 200 SUS [20 - 43 cSt]	10,000 SUS [2158 cSt]	18/13	Automotive multi-viscosity oils and ATF are not recommended
Char-Lynn J, R, and S Series Motors, and Disc Valve Motors	70 SUS [13 cSt]	100 - 200 SUS [20 - 43 cSt]	10,000 SUS [2158 cSt]	18/13	
Char-Lynn A Series and H Series Motors	100 SUS [20 cSt]	100 - 200 SUS [20 - 43 cSt]	10,000 SUS [2158 cSt]	18/13	
Char-Lynn Steering Control Units, Priority and Control Valves	55 SUS [9 cSt]	100 - 200 SUS [20 - 43 cSt]	10,000 SUS [2158 cSt]	18/13	When emergency manual steering is required, maximum viscosity is 2,000 SUS [450 cSt]
Gear Pumps and Motors, and Cylinders	45 SUS [6 cSt]	60 - 200 SUS [10 - 43 cSt]	10,000 SUS [2158 cSt]	18/13	

\* MINIMUM VISCOSITY APPLIES AT INTERMITTENT CONDITION OF 10% OF EVERY MINUTE.

### Additional Notes:

- Fluids too thick to flow in cold weather start-ups will cause pump cavitation and possible damage. Motor cavitation is not a problem during cold start-ups, except for two speed motors. Thick oil can cause high case pressures which in turn cause shaft seal problems.
- When choosing a hydraulic fluid, all the components in the system must be considered and the optimum viscosity range adjusted accordingly. For example, when a medium duty piston pump is combined with a Disk Valve Motor the optimum viscosity range becomes 100 - 180 SUS [20 - 39 cSt] and viscosity should never fall below 70 SUS [13 cSt].

- If the natural color of the fluid has become black it is possible that an overheating problem exists.
- If the fluid becomes milky, water contamination may be a problem.
- Take fluid level reading when the system is cold.
- Contact your Eaton representative if you have specific questions about the fluid requirements of Eaton hydraulic components.

**Eaton**  
Fluid Power Group  
Hydraulics Group USA  
14615 Lone Oak Road  
Eden Prairie, MN 55344  
USA  
Tel: 952-937-9800  
Fax: 952-294-7722  
[www.eaton.com/hydraulics](http://www.eaton.com/hydraulics)

**Eaton**  
Fluid Power Group  
Hydraulics Group Europe  
Route de la Longeraie 7  
1110 Morges  
Switzerland  
Tel: +41 (0) 21 811 4600  
Fax: +41 (0) 21 811 4601

**Eaton**  
Fluid Power Group  
Hydraulics Group Asia Pacific  
11th Floor Hong Kong New World Tower  
300 Huaihai Zhong Road  
Shanghai 200021  
China  
Tel: 86-21-6387-9988  
Fax: 86-21-6335-3912