

# MODEL 6000 SECTIONAL VALVE

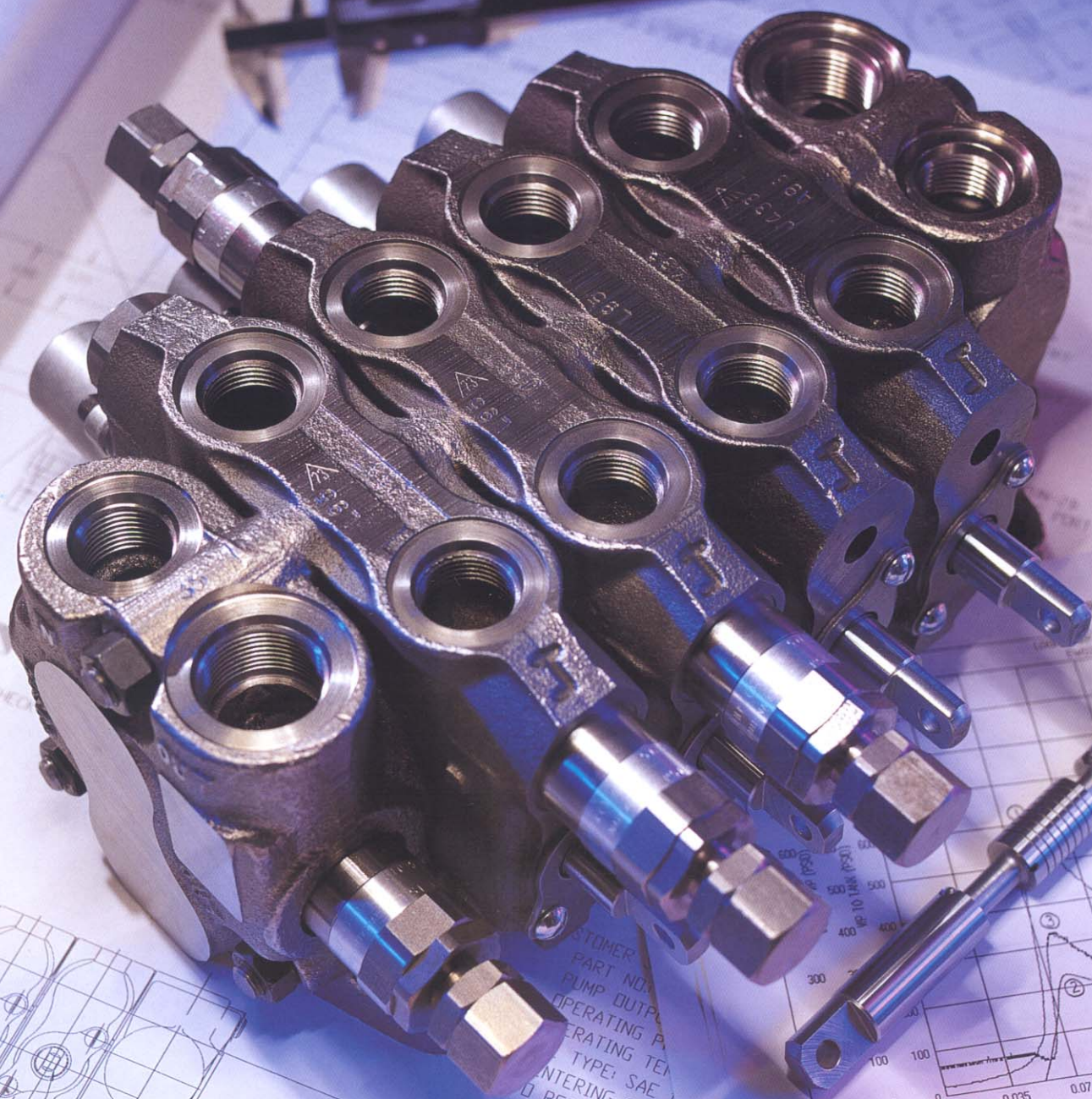

INDICATE NO CHECK

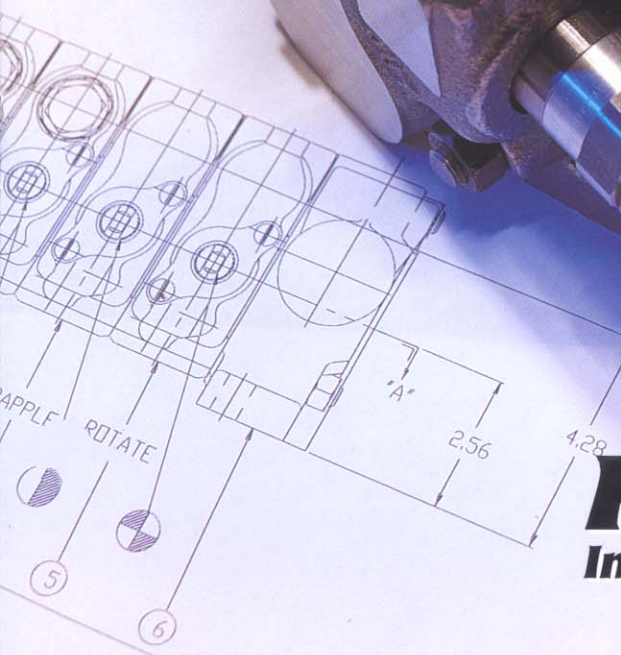

CUSTOMER PART NO. PUMP OUTPUT OPERATING TEMPERATURE TYPE: SAE CENTERING SPRING RETURN SPOOLS ABOVE INFORMATION.

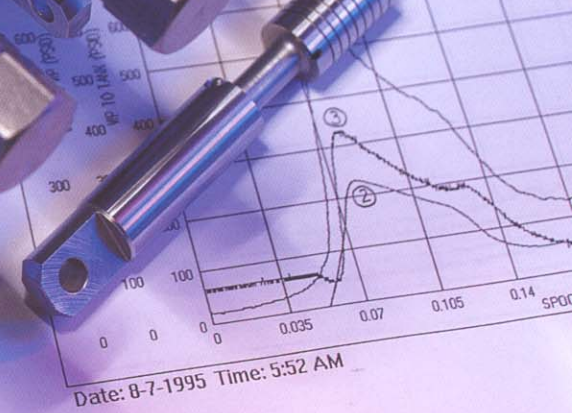

# HUSCO

International

VALVE TO  
SI @ 40 GPM  
A) 1000 PSI  
SPOOLS TO BE AS  
EXCEPT 4A & 4B MOTOR  
B) LOAD CHECK, ALL PORTS  
EXCEED 10 CIPM EXC  
MOTOR SPOOL  
4) SPECIAL SPOOL  
TP-10

# MODEL 6000 SECTIONAL CUTAWAY

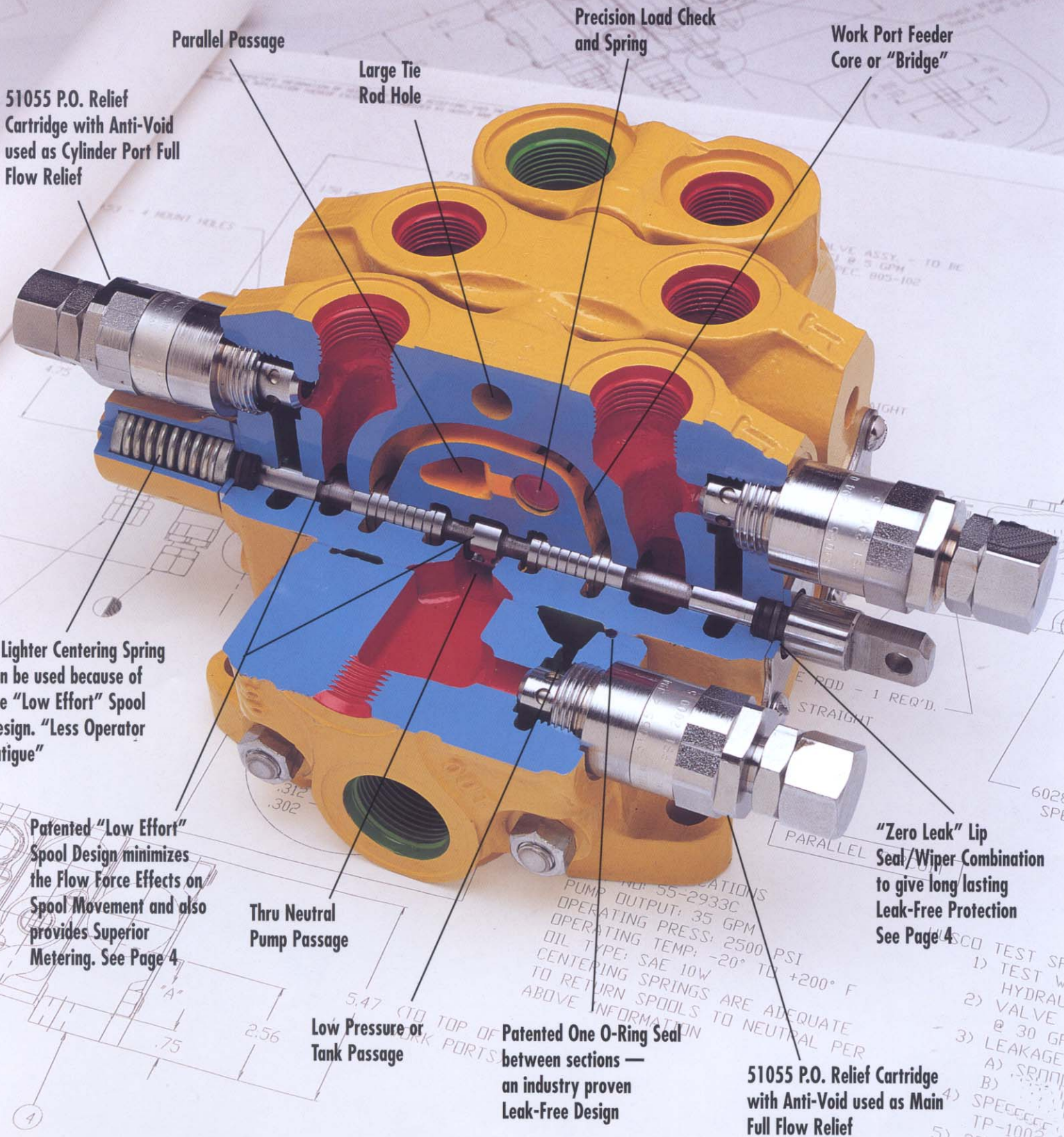

Parallel Passage

Precision Load Check  
and Spring

Work Port Feeder  
Core or "Bridge"

51055 P.O. Relief  
Cartridge with Anti-Void  
used as Cylinder Port Full  
Flow Relief

Large Tie  
Rod Hole

A Lighter Centering Spring  
can be used because of  
the "Low Effort" Spool  
Design. "Less Operator  
Fatigue"

Patented "Low Effort"  
Spool Design minimizes  
the Flow Force Effects on  
Spool Movement and also  
provides Superior  
Metering. See Page 4

Thru Neutral  
Pump Passage

Low Pressure or  
Tank Passage

Patented One O-Ring Seal  
between sections —  
an industry proven  
Leak-Free Design

"Zero Leak" Lip  
Seal/Wiper Combination  
to give long lasting  
Leak-Free Protection  
See Page 4

51055 P.O. Relief Cartridge  
with Anti-Void used as Main  
Full Flow Relief

PUMP NO: 55-2933C  
OPERATING OUTPUT: 35 GPM  
OPERATING PRESS: 2500 PSI  
OIL TYPE: SAE 10W  
CENTERING SPRINGS ARE ADEQUATE  
TO RETURN SPOOLS TO NEUTRAL PER  
ABOVE INFORMATION

TEST SPEC  
1) TEST WIT  
HYDRAULI  
2) VALVE TO  
@ 30 GPM,  
3) LEAKAGE R  
A) SPOOL S  
B) SPOOL S  
4) SPECIFIC  
TP-1002 & T  
5) SPOOL CENTE

5.47 (TO TOP OF  
WORK PORTS)

2.56  
.75

.312  
.302

PARALLEL

STRAIGHT

REQ'D.

6028  
SPEC.

4

# MODEL 6000

The Model 6000 sectional valve is a directional control valve designed for use with parallel, conventional and series circuit hydraulic systems, of open or closed center types. Model 6000 inlets, mid-inlets, outlets and spool sections provide a compact envelope to save space.

Standard spool types include single acting, double acting, motor and double acting float, with non-standard custom designed spools available.

Most design requirements can be met with a variety of work port options and end mechanisms.

## FEATURES

- “Low effort” spools
- “Zero leak” spool seals } see page 4.
- 4000 psi maximum operating pressure — see page 6.
- Open center or closed center operation.
- Hard chrome plated spools.
- Load check in each section.
- Single “low pressure” O-ring sealing between sections.
- Precision metering.

## OPTIONS

- High pressure carry over (Power Beyond).
- Lock-Out spool section.\*
- Mid-inlet check/upstream flow combiner or separator.
- Left hand spool sections.
- Parallel, Conventional and Series circuitry.
- End Mechanisms:
  - Spring centered;
  - Detent — single or multi-position;
  - 4th position float;
  - Hydraulic pilot operated;
  - Automatic kickout;
  - Magnetic detent\*.
- Auxiliary Valves:
  - Pilot operated, anti-cavitation check combination; relief cartridges.
  - Anti-cavitation; cartridges.
- Regenerative spools\*
- Specialized spools\*

\*Consult factory

### ValveCad™ Software Package For Your AutoCAD® System

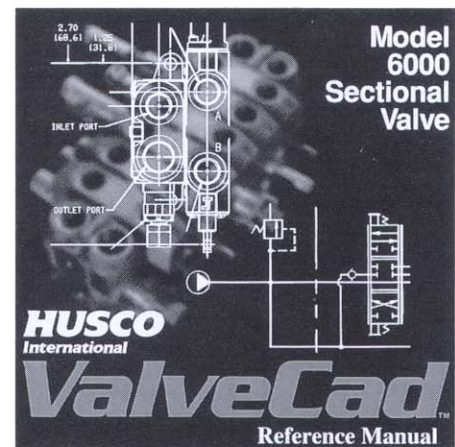

With the ValveCad Software Package, you can place all the dimensional and circuit information on components, options and accessories for the HUSCO Model 6000 sectional control valve directly into your AutoCAD® drawing system. This will significantly increase the speed, accuracy and efficiency of your design process, and help you produce specification drawings in a fraction of the time required to redraw the parts from scratch.

Information about obtaining and using the ValveCad package for your application is available from your local HUSCO Distributor or directly from the factory.

## “LOW EFFORT” SPOOLS

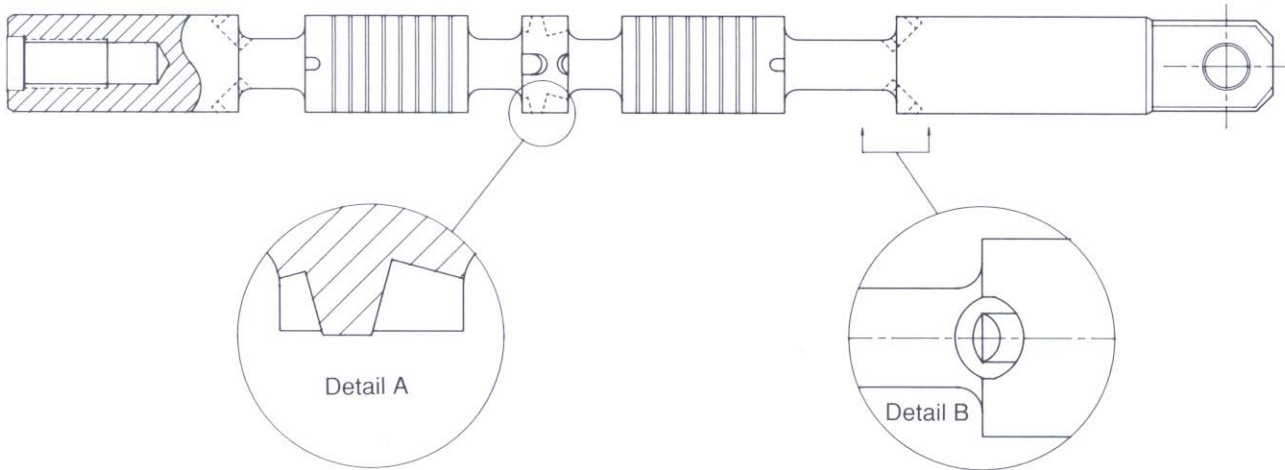

The term “Low Effort” was associated with this spool type as a result of the successful design efforts to reduce the variety of flow forces on the spool during operation.

The machined notch design in detail A directs the **fluid entering** the spool land area in such a way as to create a reactionary force on the spool that reduces the force created by the high velocity. The machined notch in detail B cushions the **exhausting fluid** from the land area by directing the initial flow jet back against the housing land when the grooves are first exposed, then vertical to the spool axis as the groove completely opens.

The combined effect of both notch types not only reduces the flow forces for easier spool movement and with less operator fatigue, it also provides a spool with an increased metering band for superior control, especially during multifunction operations.

For the reasons above and many years of proven successful applications of “low effort” spool type design, Model 6000 spool sections equipped with “low effort” type spools became the obvious choice to feature in the Model 6000 catalog.

## “ZERO LEAK” SEALS

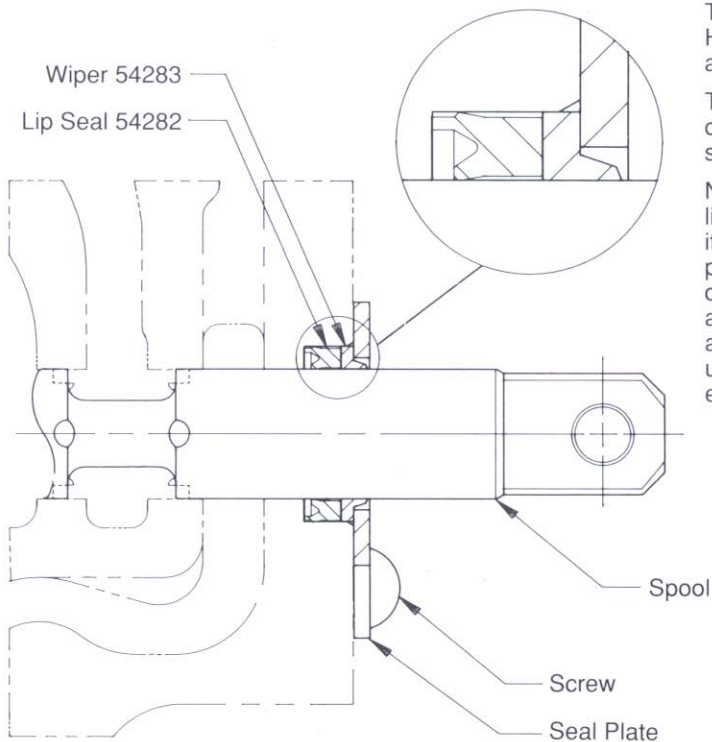

Through many hours of research and testing, HUSCO International has determined the best seal arrangement to keep your system **dry**.

This seal arrangement has been incorporated into our standard catalog offering of Model 6000 spool sections and specified as “Zero Leak” seals.

Note: The “Zero Leak” seal arrangement contains a lip seal that requires a special tool and procedure for its installation in the field. Consult factory for this procedure. The machined groove for spool end seals did not change to accommodate the “Zero Leak” arrangement. Therefore, the previous P/N 571 O-ring and P/N 4137 back-up ring combination can be used. These are still used on end mechanism kits for ease of field installation.

# TABLE OF CONTENTS

	Page
Features and Options .....	3
“Low Effort” Spools .....	4
“Zero Leak” Seals .....	4
Pressure Drop Curves .....	6
Technical Data .....	6
Dimensional Data in Inches (Millimeters).....	7
Inlet End Section Assemblies (L.H. Covers).....	8-10
Inlet Sections .....	8
Inlet/Outlet Sections (cutaway photo pg. 19).....	9
Mid-Inlet Sections .....	10
Spool Section Assemblies .....	11-15
Parallel Circuit Manually Operated Sections.....	11
Parallel Circuit Hydraulic Remote Sections .....	12
Parallel Circuit Pneumatic Remote Sections .....	13
Conventional (Tandem) Circuit Manually Operated Sections .....	14
Series Circuit Manually Operated Sections .....	15
Outlet Section Assemblies (R.H. Covers).....	16-18
End Outlet/Turnaround Sections .....	16
Power Beyond/Closed Center Sections .....	17
Universal Outlet/Optional P.B. Sections (cutaway photo pg. 19).....	18
Cutaway photo of Inlet P/N 6001D102 and Outlet P/N 6003D49 .....	19
Relief Valve Assemblies.....	20
Auxiliary Valve and Tie Rod Information .....	21
Lever Assemblies .....	22
End Mechanisms ■ Service and Kit Information.....	23-24
Spring Ctr. ■ Detents ■ Detent Float.....	23
Hydraulic Remote ■ Pneumatic Remote.....	24
Appendices	
Appendix 1 Automatic Kickout Feature (ordering information pg. 14) .....	25
Appendix 2 Spool End Orientation/Cable Connectors .....	26
Appendix 3 Basic Casting Identification.....	26
Appendix 4 P.O. Relief and Anti-Void Operation.....	27
Appendix 5 P.O. Relief and Anti-Void Maintenance Procedure .....	28
Appendix 6 Valve Assembly Procedure .....	29
Appendix 7 Valve Assembly Specification Sheet.....	30

# PRESSURE DROP CURVES

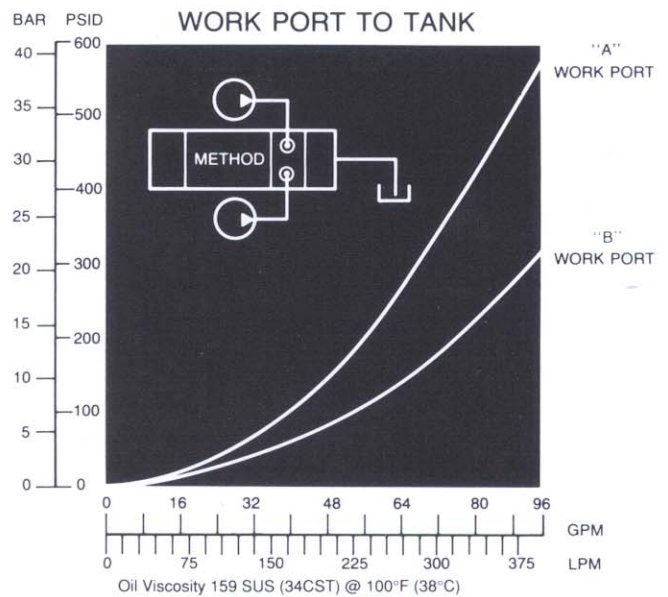
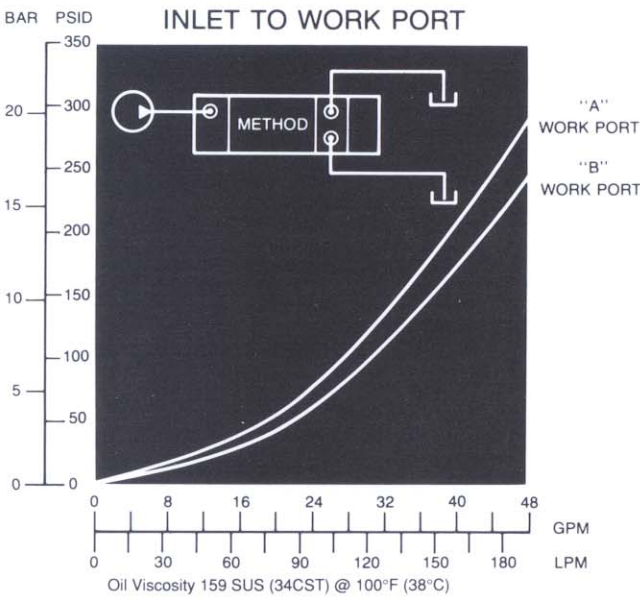
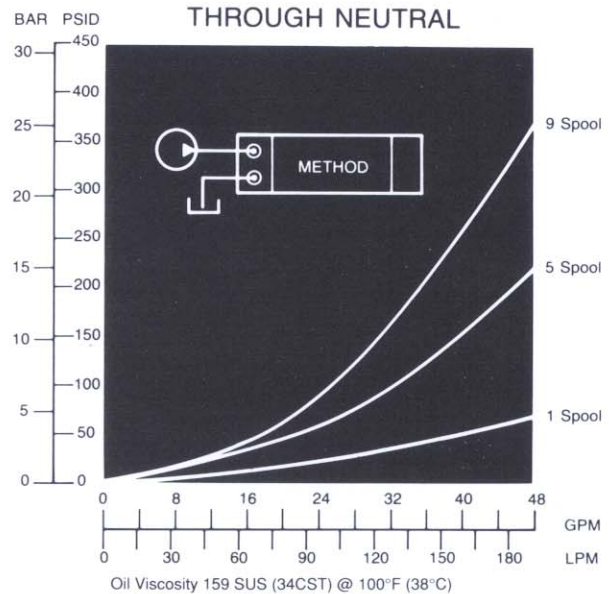
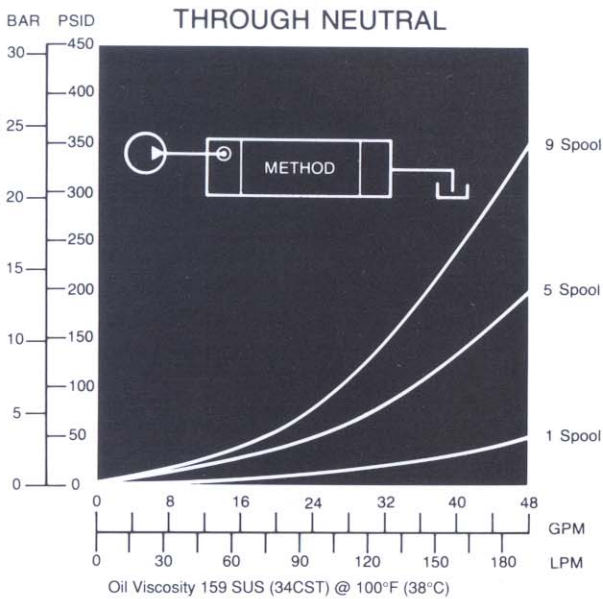

## TECHNICAL DATA

Flow rating (nominal) .....35 U.S. gpm (132 lpm)

Maximum Rated Operating Pressure  
 Parallel Spool Sections.....4000 psi (276 bar)\*  
 Conventional Spool Sections.....Consult Factory

(Method of verifying rated fatigue pressure of the pressure containing envelope conforms to NFPA Recommended Std., NFPA / 2.6.1 -1974 Category 1/90)

Seals .....Buna-N Standard  
 Vitron Optional

Recommended  
 Filtration .....10 micron nominal

Maximum number of spool sections (any combination of) per valve assembly.....10

Maximum outlet port pressure.....250 PSI

We reserve the right to amend these specifications at any time without notice. The only warranty applicable is our standard written warranty. We make no other warranty, expressed or implied.

Performance characteristics shown are typical of production units tested in the laboratory and are not necessarily representative of any one unit.

\* Consult factory-certain port sizes may reduce this rating.

# MODEL 6000 VALVE ASSEMBLY

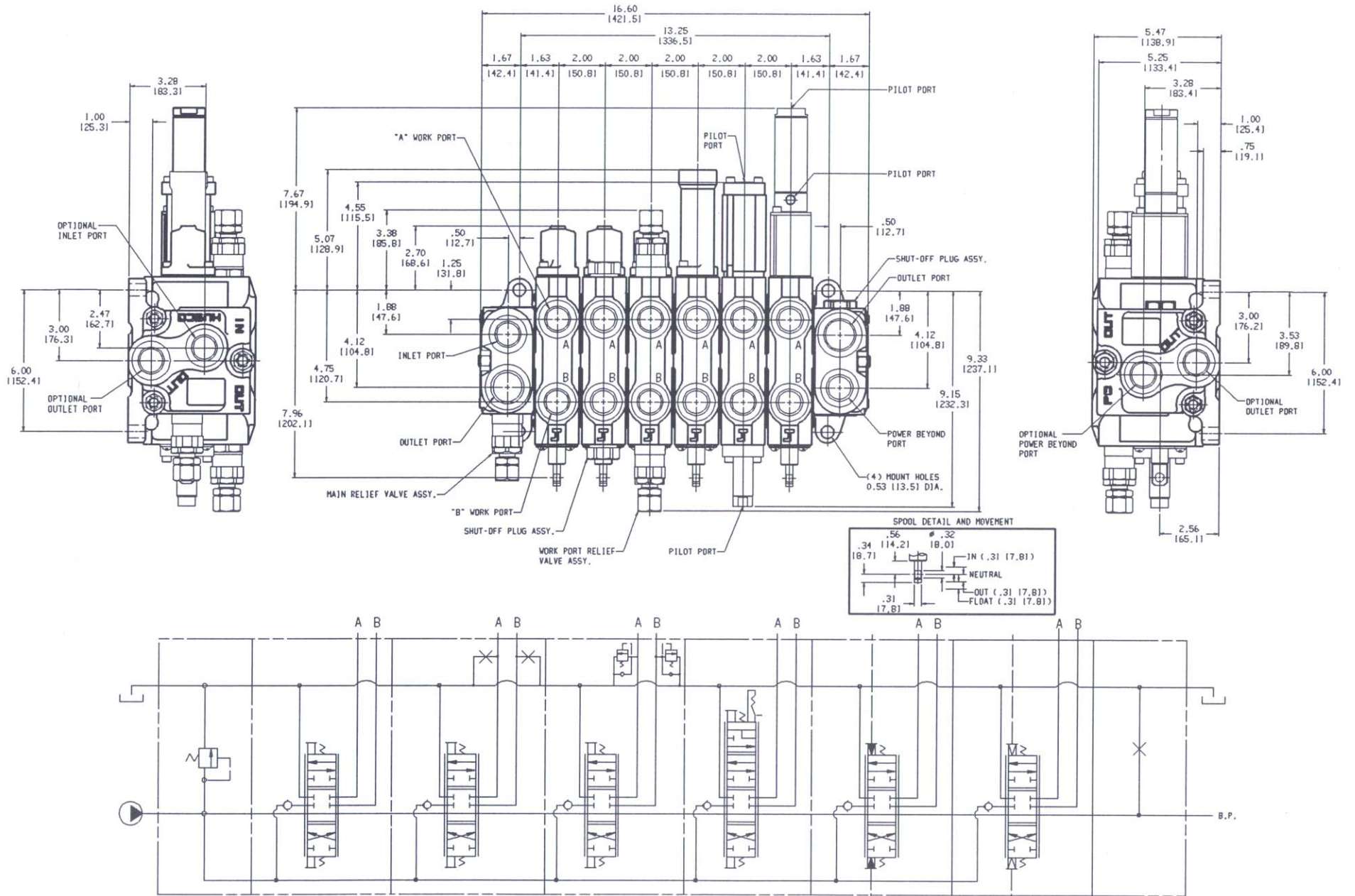

# INLET SECTION ASSEMBLIES

WITH AUXILIARY PORT FOR MAIN RELIEF VALVE.  
END INLET AND SIDE GAGE PORT (PLUGGED)

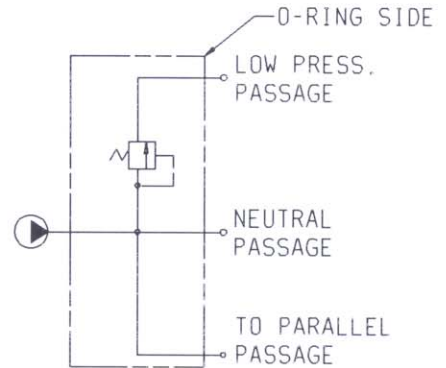
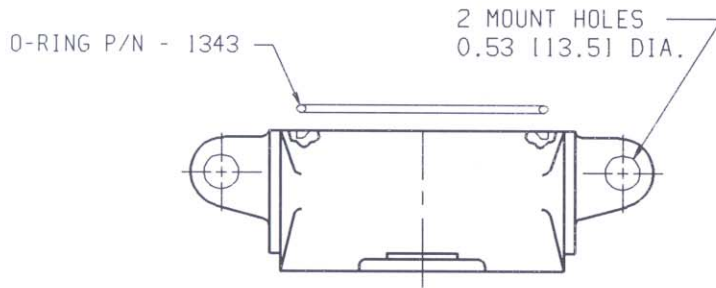

CIRCUIT SHOWN WITH R.V. INSTALLED  
(R.V. SOLD SEPARATELY)

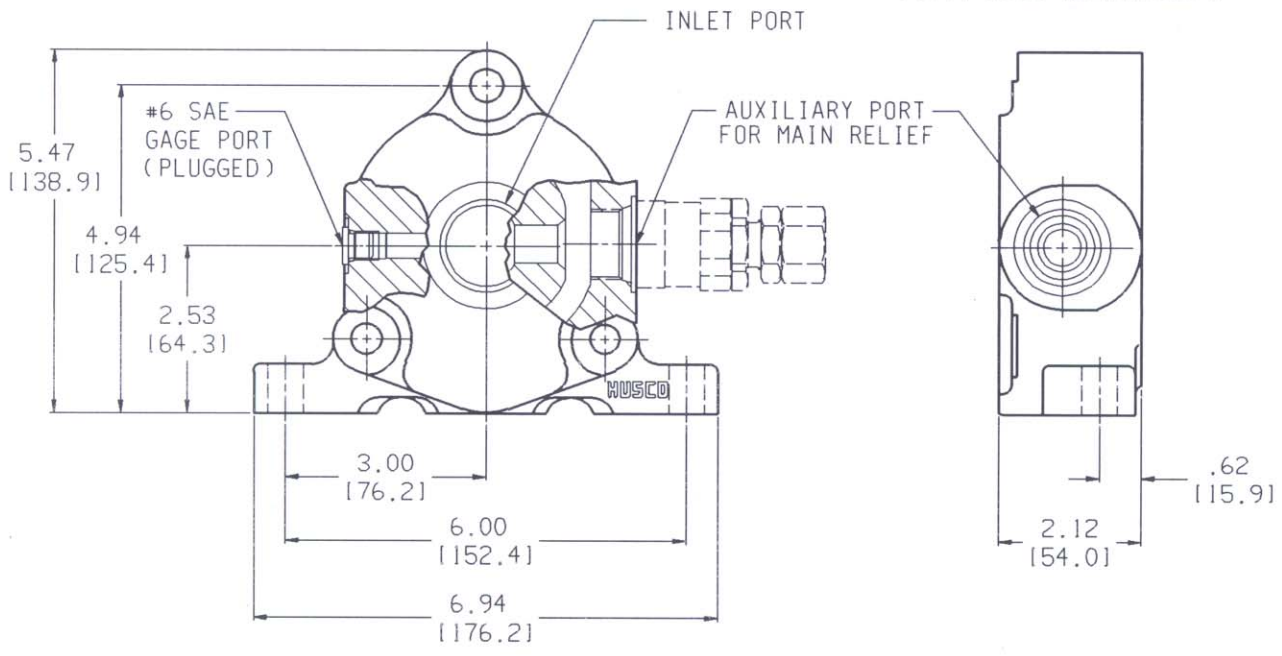

PORT SIZE	INLET SECTION PART NUMBER (51055 R.V.)
SAE 16	6001-J11

USED IN SECTION ① OF THE VALVE  
ASSEMBLY SPECIFICATION SHEET (Pg 30)

WEIGHT:  
APPROX. 9 LBS [4.1 kg]



# INLET/OUTLET SECTION ASSEMBLIES

WITH AUXILIARY PORT FOR MAIN RELIEF VALVE.  
TOP INLET / OUTLET PORTS AND OPTIONAL END  
INLET / OUTLET PORTS

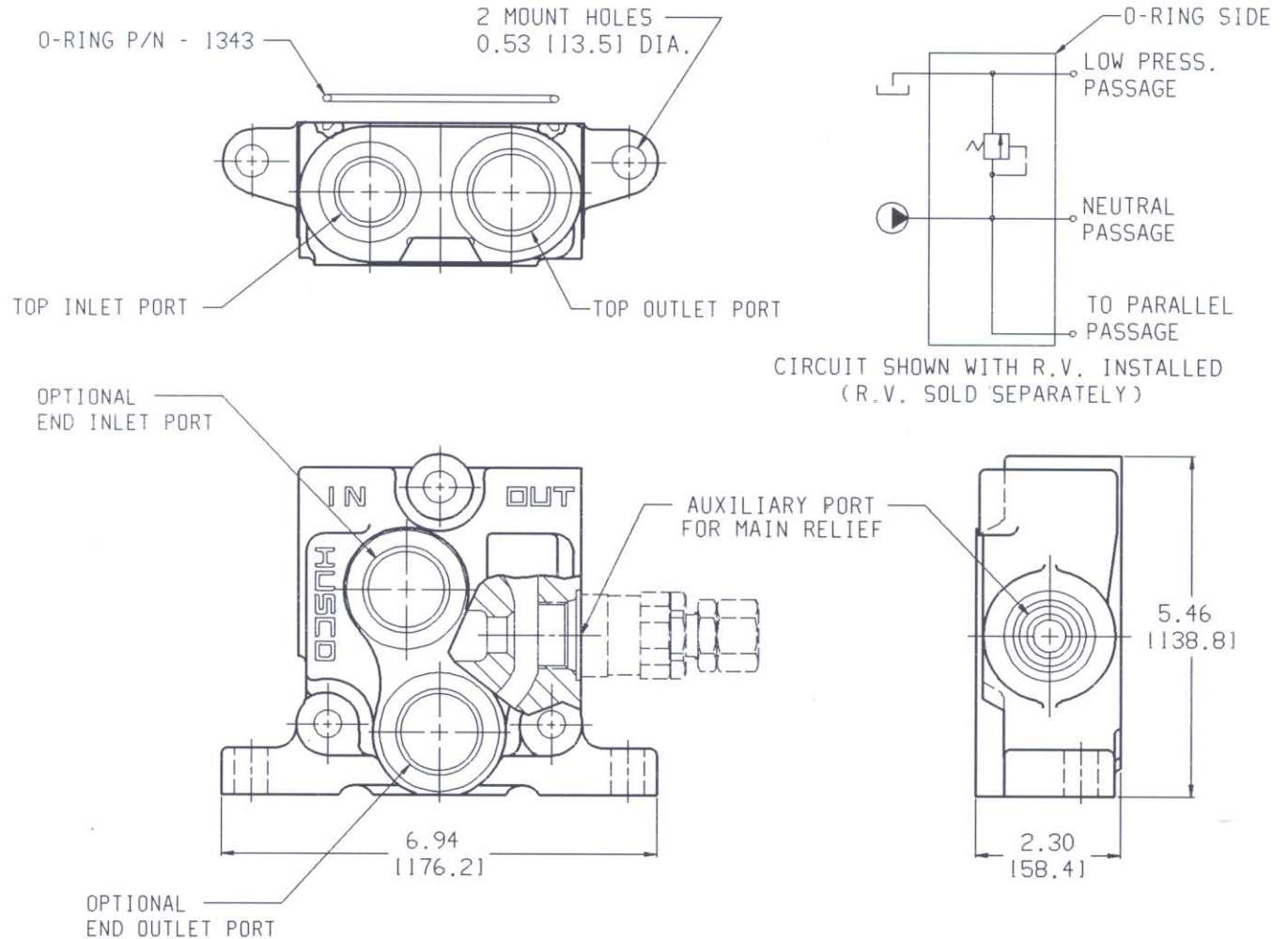

PORT SIZES				INLET SECTION PART NUMBER (51055 R.V.)
INLET		OUTLET		
TOP	END	TOP	END	
SAE 12	NONE	SAE 16	NONE	6001-D100
SAE 12	SAE 16	SAE 16	SAE 16	6001-D102

USED IN SECTION ① OF THE VALVE  
ASSEMBLY SPECIFICATION SHEET (Pg 30)

SEE PAGE 7 FOR ADDITIONAL DIMENSIONAL INFORMATION

WEIGHT:  
APPROX. 10 LBS. (4.5 kg)

# MID-INLET SECTION ASSEMBLIES

MUST BE ORDERED IN CONJUNCTION WITH ONE OF THE OPTIONS SHOWN (BELOW)

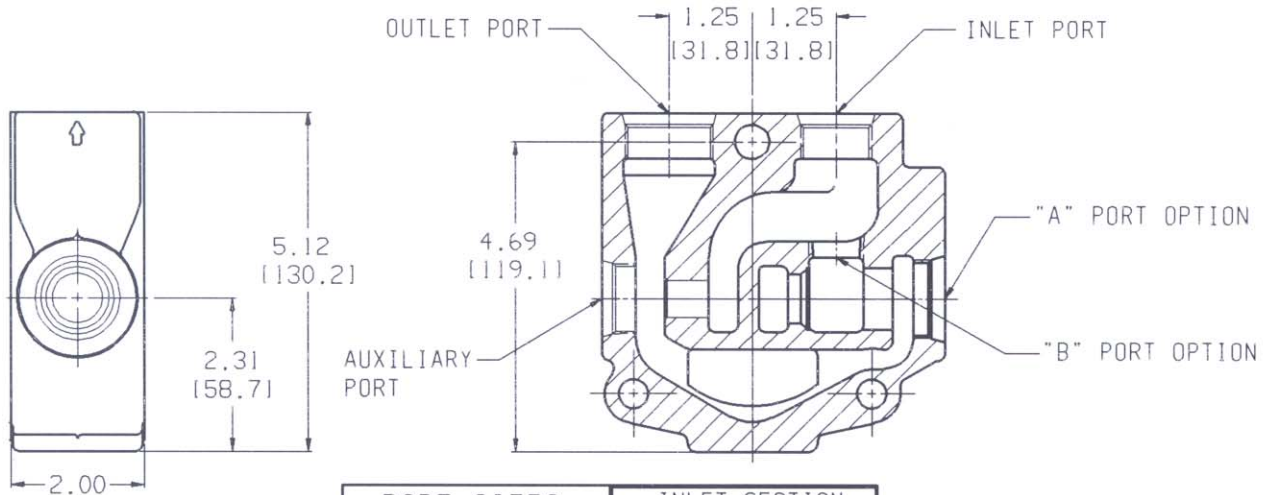

PORT SIZES		INLET SECTION PART NUMBER (51055 R.V.)
INLET	OUTLET	
SAE 12	SAE 16	6001-M21

WEIGHT:  
APPROX. 7 LBS (3.2kg)

USED IN SECTION ② OF THE VALVE  
ASSEMBLY SPECIFICATION SHEET (Pg 30)

## MID-INLET COMBINER OPTION

TO COMBINE INLET FLOW ORDER  
THIS CHECK VALVE ASSY AND INSTALL  
IN "A" OPTION PORT OF MID-INLET

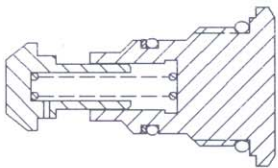

PART NUMBER
52664

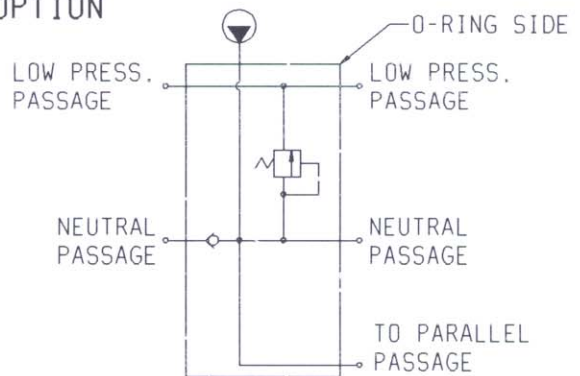

CIRCUIT SHOWN WITH R.V. INSTALLED  
(R.V. SOLD SEPARATELY)

## MID-INLET SEPARATE FLOW OPTION

TO SEPARATE INLET FLOW ORDER THIS PIPE  
PLUG AND INSTALL INTO "B" PORT OPTION  
AND ALSO THIS SAE PLUG AND INSTALL INTO  
"A" PORT OPTION.

DESCRIPTION	PART NUMBER
PIPE PLUG	229
SAE 14	11240

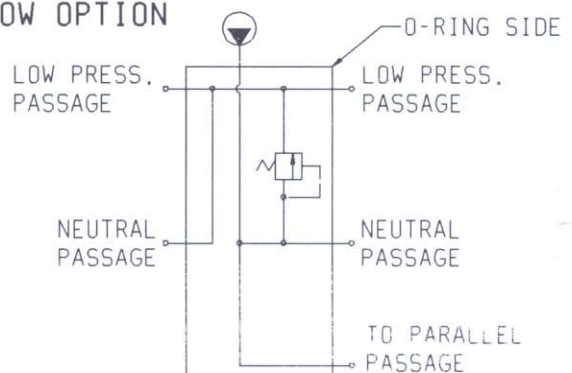

CIRCUIT SHOWN WITH R.V. INSTALLED  
(R.V. SOLD SEPARATELY)

# PARALLEL CIRCUIT MANUALLY OPERATED SPOOL SECTION ASSEMBLIES

FEATURES HUSCO PATENTED "LOW EFFORT" SPOOLS  
AND "ZERO LEAK" SPOOL SEALS

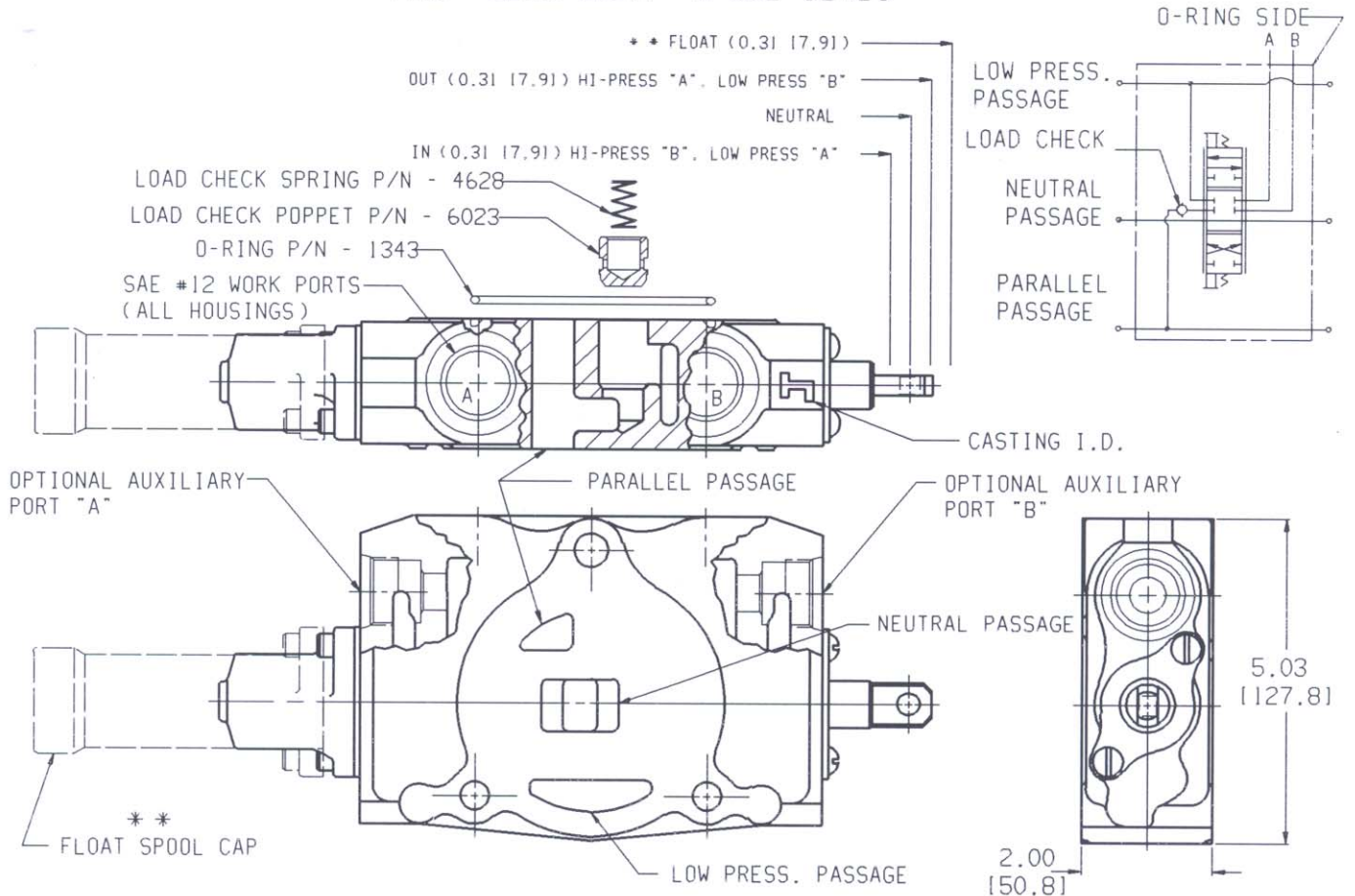

3 POS. - 4 WAY		SPOOL SECTION ASSY PART No.			
SPOOL AND END MECHANISM IN → OUT	SPOOL P/N:	END MECHANISM KIT P/N:	WITH NO AUX. VALVE PORTS	WITH 51055 STYLE AUX PORTS	
SPRING CTR	51054	D10-200			6002-J433 6002-J387
3 POS. DETENTED	51054	D11-100			6002-J411 6002-J413
SPRING CTR FLT IN NEUTRAL (MOTOR)	51476	D10-200			6002-J154 6002-J394
3 POS DETENTED FLT IN NEUTRAL (MOTOR)	51476	D11-100			6002-J328 6002-J395
3 POS. - 3 WAY					
SPRING CTR (SINGLE ACTING)	51425	D10-200			6002-J332 6002-J396
** 4 POS. - 4 WAY					
SPRING CTR DETENTED FLT	52092	D11-204			6002-J336 6002-J397

STANDARD SPRING CENTERING FORCES  
(SPRING P/N: 3329B) = 37 LBS.

USED IN SECTION ② OF THE VALVE  
ASSEMBLY SPECIFICATION SHEET (Pg 30)

WEIGHT:  
APPROX. 14 LBS. [6.4 kg]

SEE PAGE 7 FOR ADDITIONAL DIMENSIONAL INFORMATION

# PARALLEL CIRCUIT HYDRAULIC REMOTE (OIL PILOT OPERATED) SPOOL SECTION ASSEMBLIES

FEATURES HUSCO PATENTED "LOW EFFORT" SPOOLS

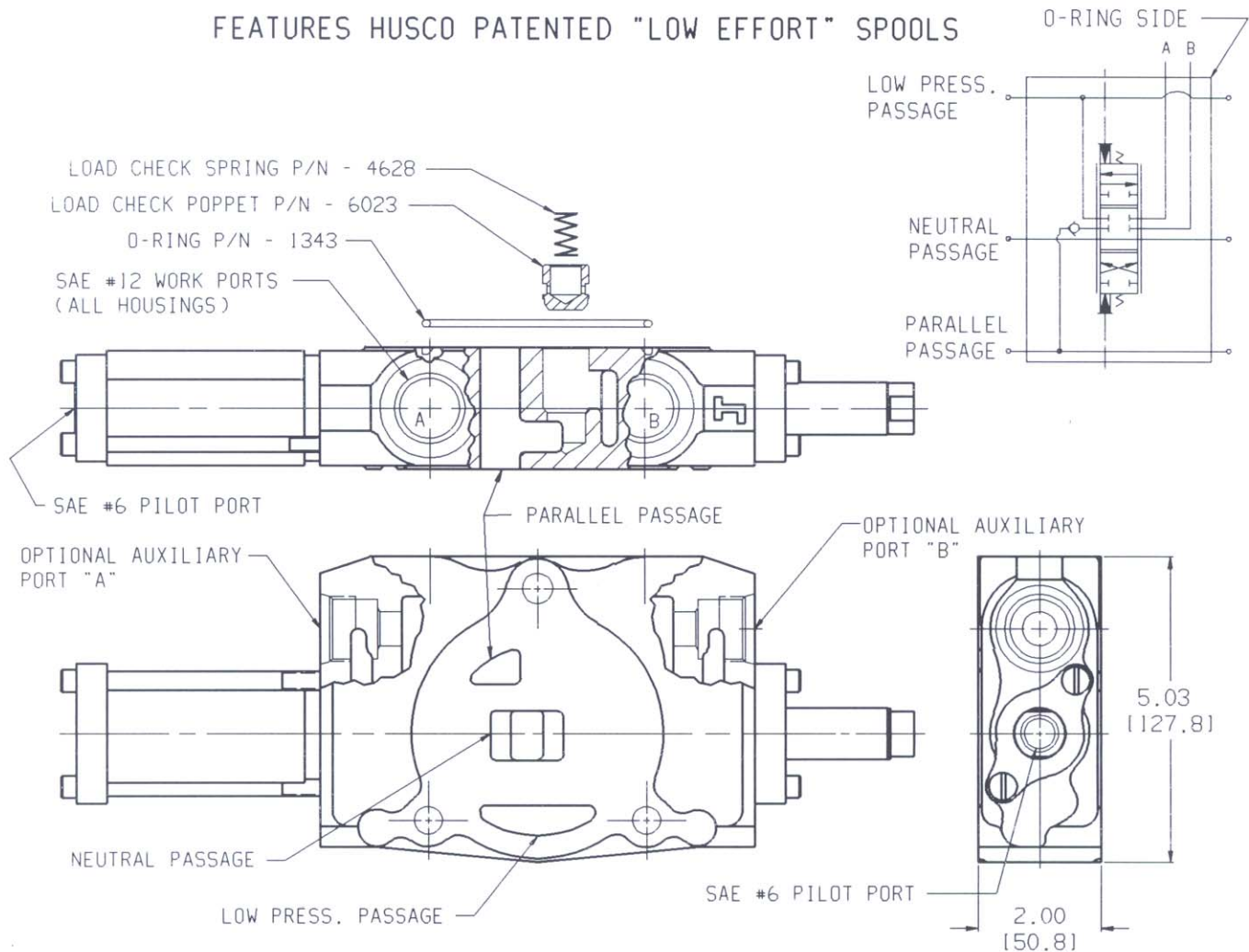

3 POS. - 4 WAY		SPOOL SECTION ASSY PART No.			
SPOOL AND END MECHANISM IN → OUT	SPOOL P/N:	END MECHANISM KIT P/N:	WITH NO AUX. VALVE PORTS	WITH 51055 STYLE AUX PORTS	
SPRING CTR	51054	D12-109	6002-J334	6002-J391	
SPRING CTR FLT IN NEUTRAL (MOTOR)	51476	D12-109	6002-J354	6002-J410	

USED IN SECTION ② OF THE VALVE ASSEMBLY SPECIFICATION SHEET (Pg 30)

SEE PAGE 7 FOR ADDITIONAL DIMENSIONAL INFORMATION

APPROXIMATE PILOT PRESSURE VS SPOOL TRAVEL  
 20 PSI -- SPOOL STARTS TO SHIFT  
 80 PSI -- FLOW BEGINS AT WORK PORT  
 360 PSI -- FULL SHIFT, FULL WORK PORT FLOW  
 1000 PSI -- MAXIMUM PILOT PRESSURE

USE WITH HUSCO MANUAL HYDRAULIC CONTROLLERS:  
 STD. SECTIONAL TYPE: P/N: 7470-A15 (1 SPOOL OPERATION)  
 STD. JOYSTICK TYPE: P/N: 7480-19 (2 SPOOL OPERATION)

WEIGHT:  
APPROX. 16 LBS. (7.2 kg)

# PARALLEL CIRCUIT PNEUMATIC REMOTE (AIR PILOT OPERATED) SPOOL SECTION ASSEMBLIES

FEATURES HUSCO PATENTED "LOW EFFORT" SPOOLS  
AND "ZERO LEAK" SPOOL SEALS

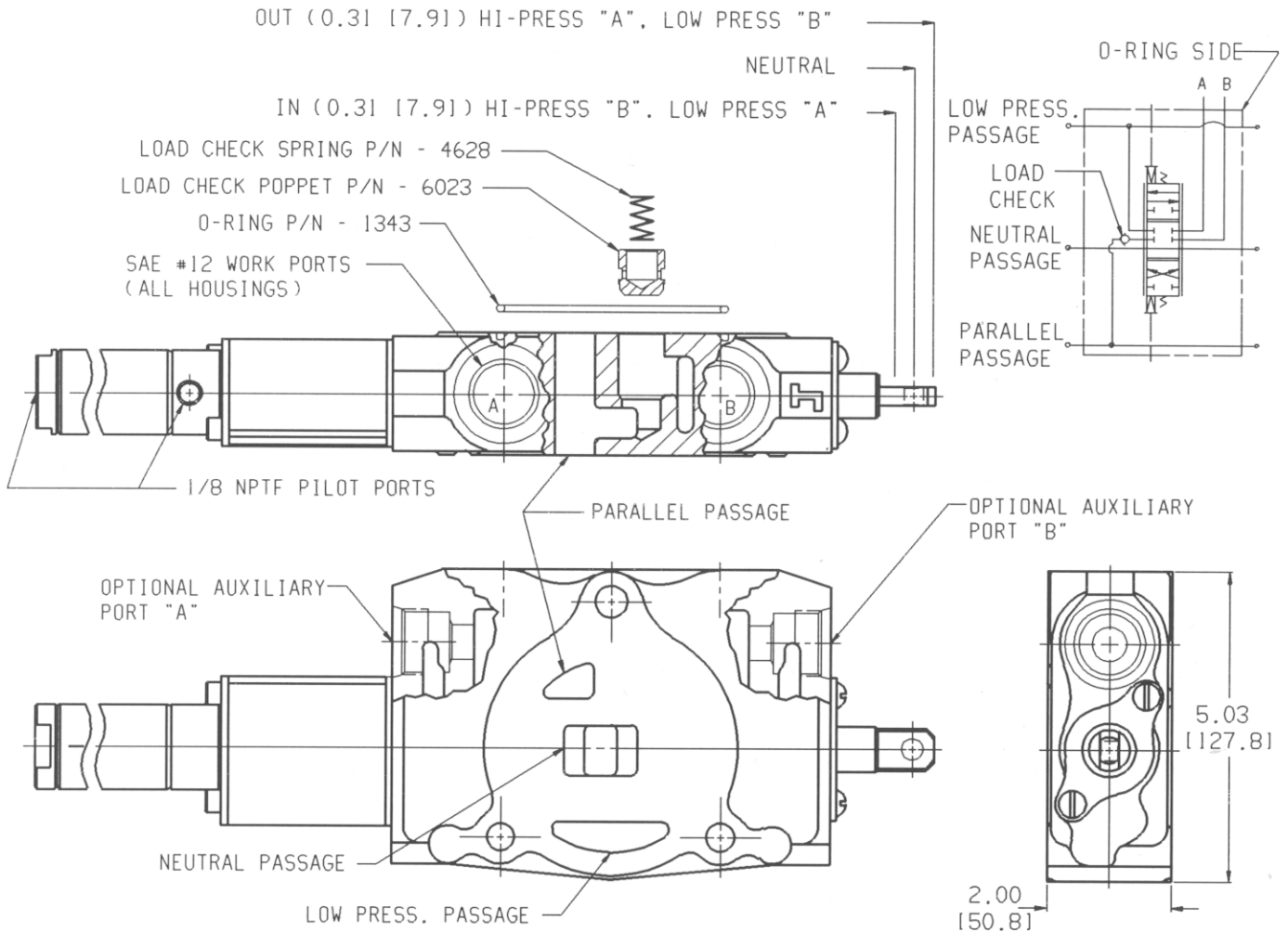

3 POS. - 4 WAY		SPOOL SECTION ASSY PART No.		
SPOOL AND END MECHANISM IN → OUT	SPOOL P/N:	END MECHANISM KIT P/N:	WITH NO AUX. VALVE PORTS	WITH 51055 STYLE AUX PORTS
SPRING CTR	51054	54702	6002-J381	6002-J398
SPRING CTR FLT IN NEUTRAL (MOTOR)	51476	54702	6002-J404	6002-J406

USED IN SECTION ② OF THE VALVE ASSEMBLY SPECIFICATION SHEET (Pg 30)

SEE PAGE 7 FOR ADDITIONAL DIMENSIONAL INFORMATION





THIS CHART IS SPRING FORCE ONLY	BEGIN SPOOL SHIFT	FULL SPOOL SHIFT
BASE SIDE STROKE "OUT"	30 PSI	55 PSI
ROD SIDE STROKE "IN"	34 PSI	62 PSI

WEIGHT:  
APPROX. 16 LBS. 17.2 kg)

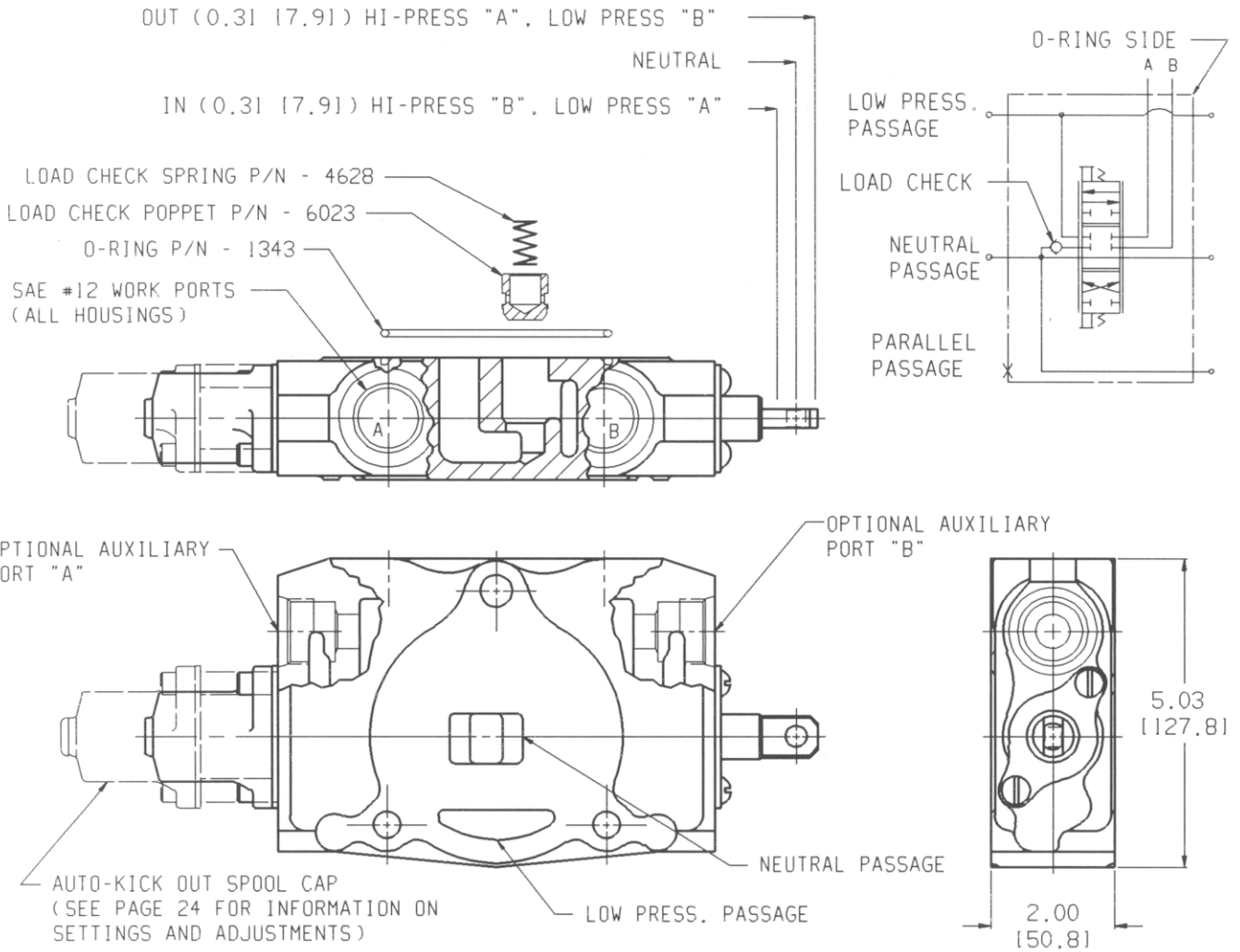
# CONVENTIONAL CIRCUIT MANUALLY OPERATED (TANDEM) SPOOL SECTION ASSEMBLIES

FEATURES HUSCO PATENTED "LOW EFFORT" SPOOLS  
AND "ZERO LEAK" SPOOL SEALS



3 POS. - 4 WAY		SPOOL SECTION ASSY PART No.			
SPOOL AND END MECHANISM IN → OUT	SPOOL P/N:	END MECHANISM KIT P/N:	WITH NO AUX. VALVE PORTS	WITH 51055 STYLE AUX PORTS	
 SPRING CTR	51054	D10-200	 6002-K142	 6002-K140	
 SPRING CENTER DETENT IN & OUT (AUTO-KICK OUT)	53169	N/A	6002-W3	6002-W23	

STANDARD SPRING CENTERING FORCES  
(SPRING P/N: 3329B) = 37 LBS.  
(DOESN'T APPLY TO AUTO-K.O. SECTION)

USED IN SECTION ② OF THE VALVE  
ASSEMBLY SPECIFICATION SHEET (Pg 30)



WEIGHT:  
APPROX. 14 LBS. [6.4 kg]

SEE PAGE 7 FOR ADDITIONAL DIMENSIONAL INFORMATION

# SERIES CIRCUIT MANUALLY OPERATED SPOOL SECTION ASSEMBLIES

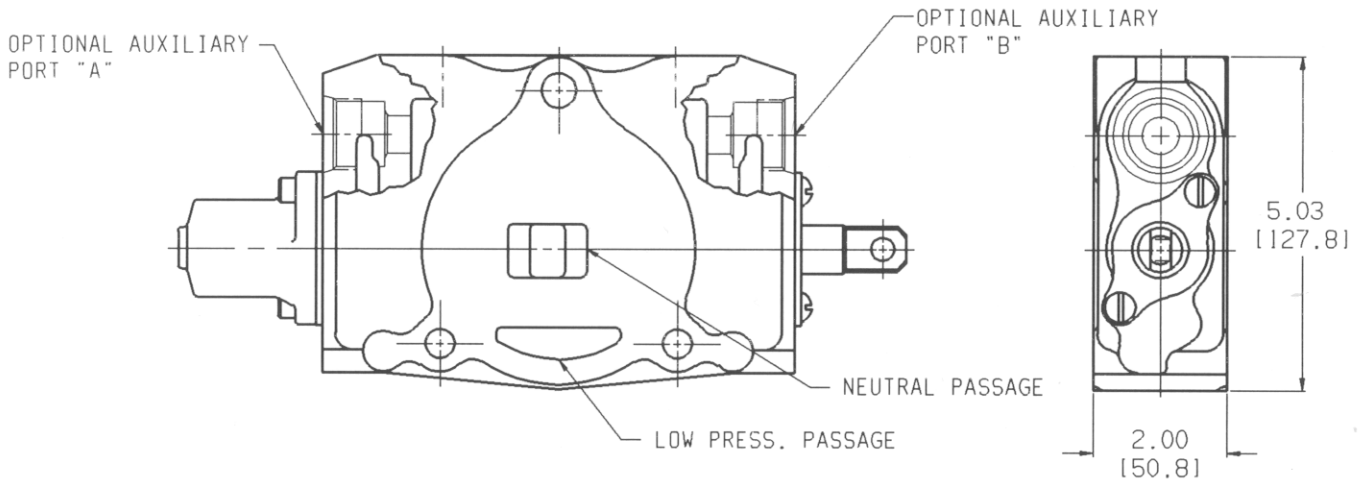
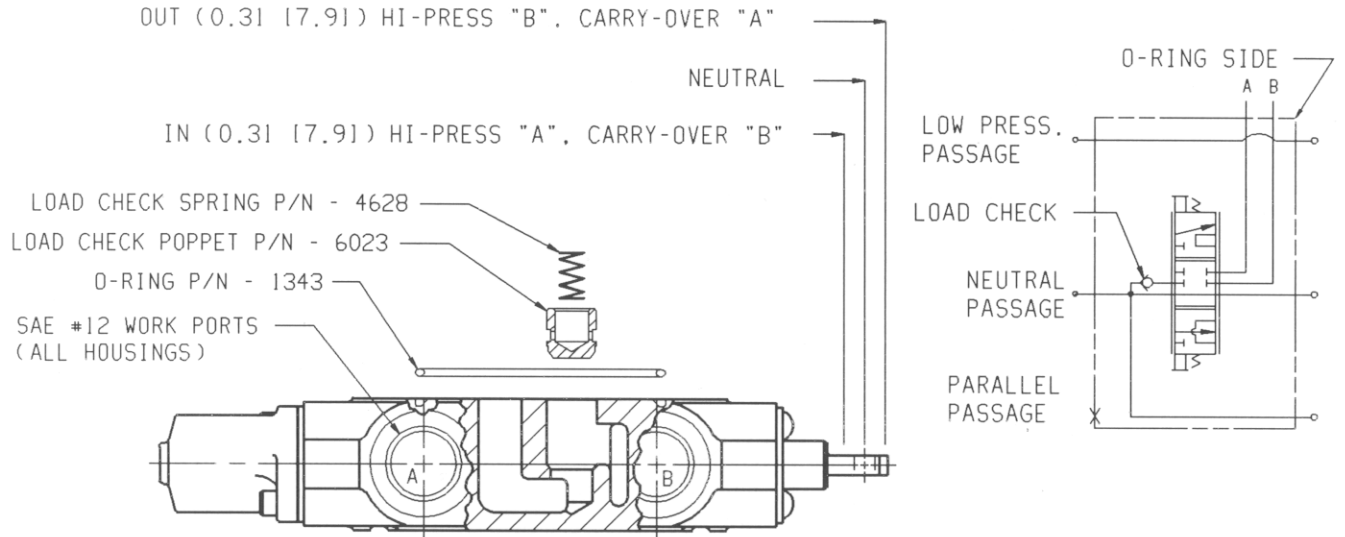
## FEATURES "ZERO LEAK" SPOOL SEALS

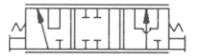

3 POS. - 4 WAY		SPOOL SECTION ASSY PART No.		
SPOOL AND END MECHANISM IN ← → OUT	SPOOL P/N: 51389	END MECHANISM KIT P/N: D10-104	WITH NO AUX. VALVE PORTS	WITH 51055 STYLE AUX PORTS
				
 SPRING CTR			6002-K27	6002-K141

STANDARD SPRING CENTERING FORCES  
(SPRING P/N: 3329E) - 45 LBS.

USED IN SECTION ② OF THE VALVE  
ASSEMBLY SPECIFICATION SHEET (Pg 30)

SEE PAGE 7 FOR ADDITIONAL DIMENSIONAL INFORMATION

WEIGHT:  
APPROX. 14 LBS. [6.4 kg]

# END OUTLET / TURNAROUND OUTLET SECTION ASSEMBLIES

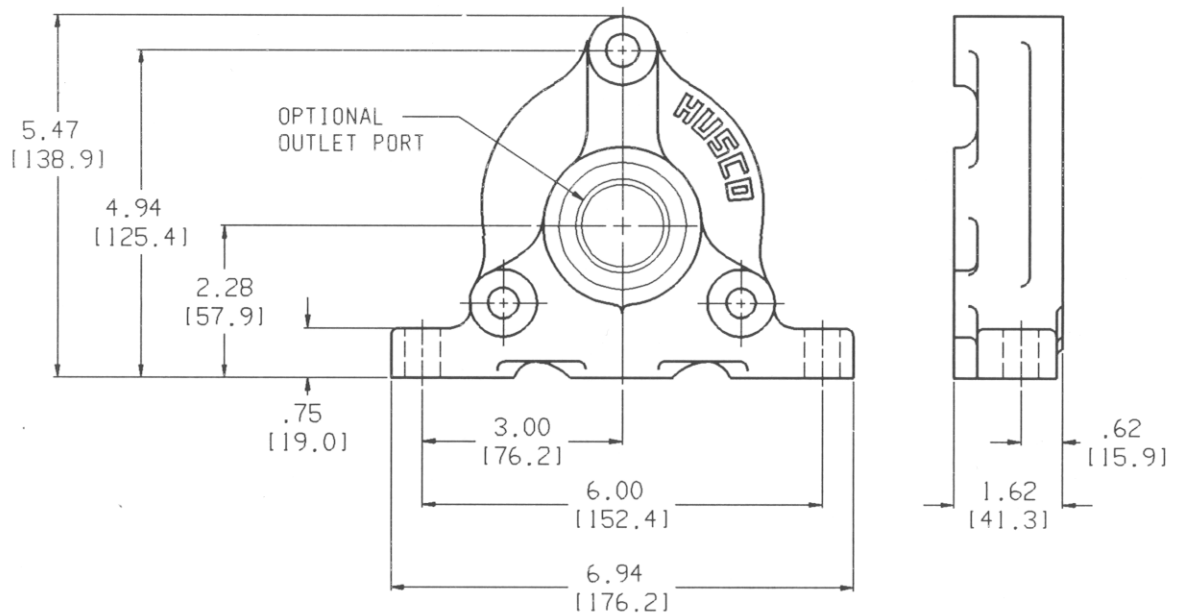
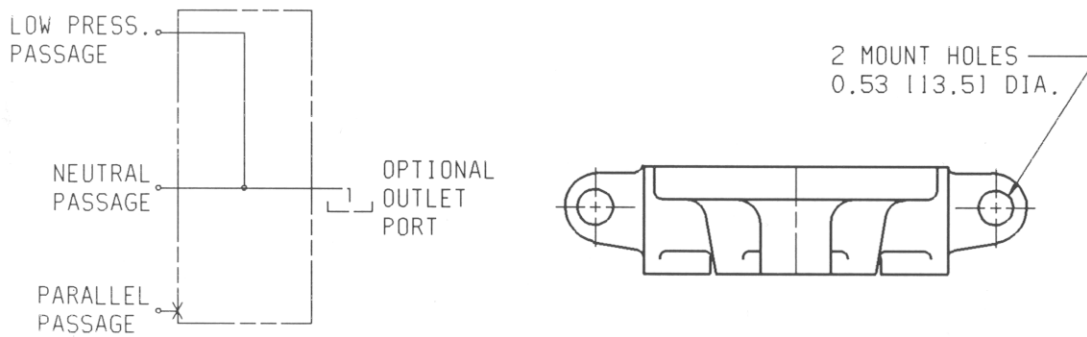

PORT SIZES	OUTLET SECTION PART NUMBERS
* NONE	6003-E1
SAE 16	6003-E2

USED IN SECTION ③ OF THE VALVE  
ASSEMBLY SPECIFICATION SHEET (Pg 30)

\* REQUIRES UPSTREAM OUTLET PORT  
SOMEWHERE ELSE IN VALVE ASSY.

WEIGHT:  
APPROX. 6 LBS. [2.7] kg



# POWER BEYOND / CLOSED CENTER SECTION ASSEMBLIES

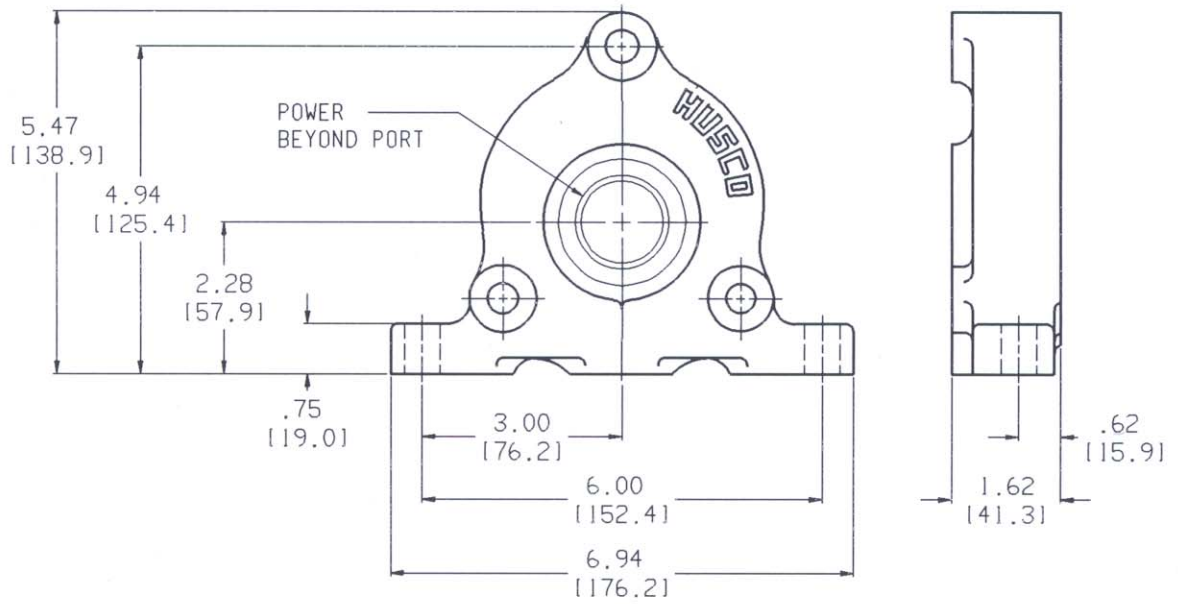
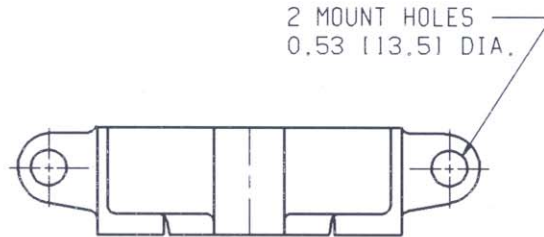
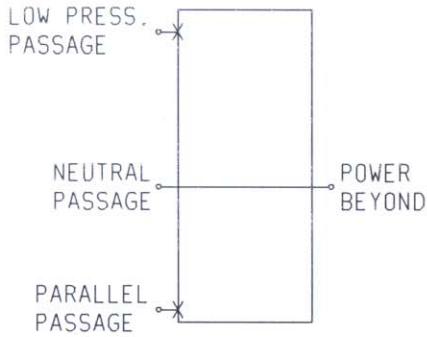

PORT SIZES	OUTLET SECTION PART NUMBERS
SAE 16	6003-K3

TO CREATE A CLOSED CENTER CIRCUIT, PLUG POWER BEYOND PORT.

REQUIRES AN UPSTREAM OUTLET PORT IN VALVE ASSY.

USED IN SECTION ③ OF THE VALVE ASSEMBLY SPECIFICATION SHEET (Pg 30)

WEIGHT:  
APPROX. 6 LBS. (2.7 kg)

# UNIVERSAL OUTLET/POWER BEYOND OPTION SECTION ASSEMBLIES

## AUXILIARY VALVE PORT CIRCUIT OPTIONS (ALL SOLD SEPARATELY)

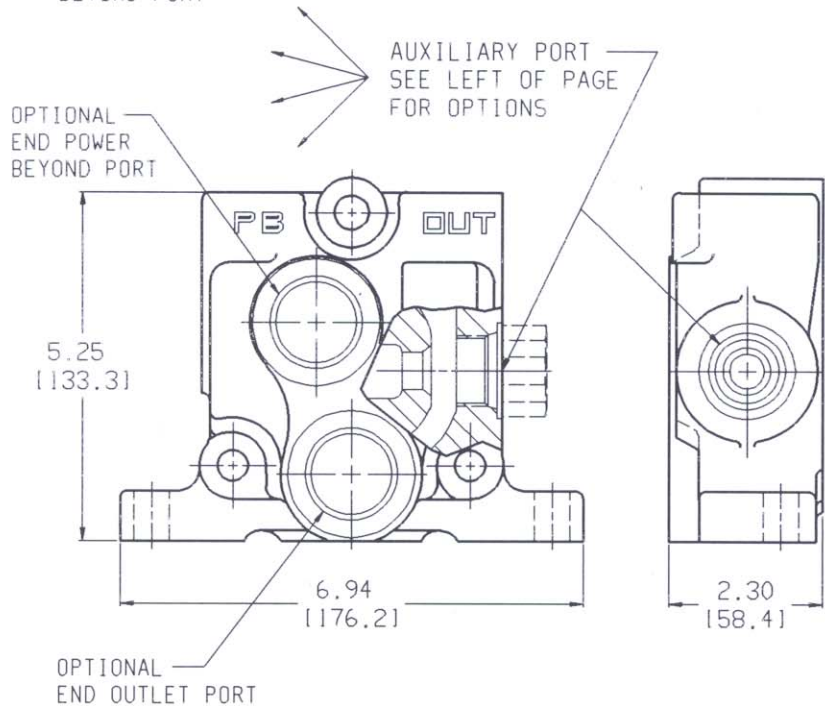
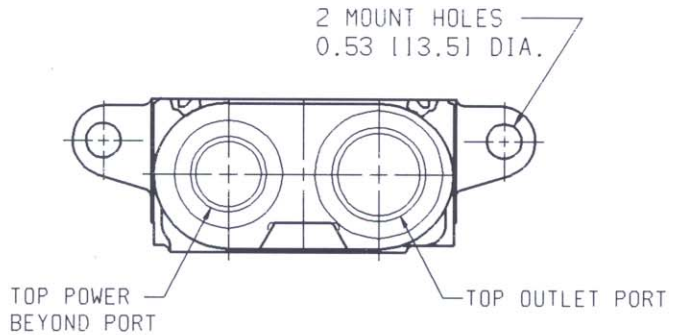
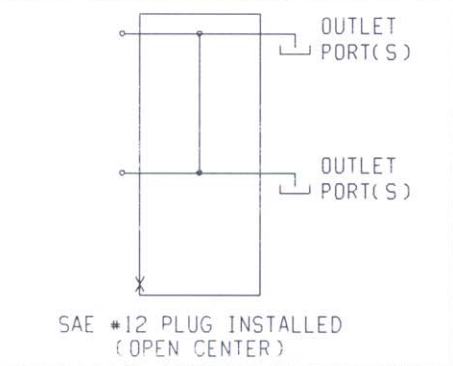
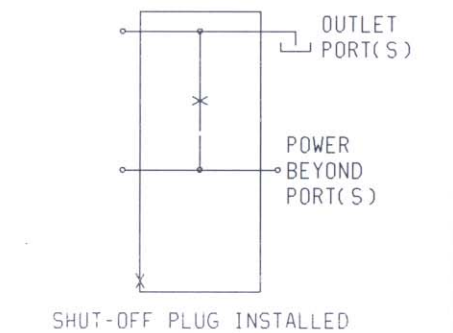
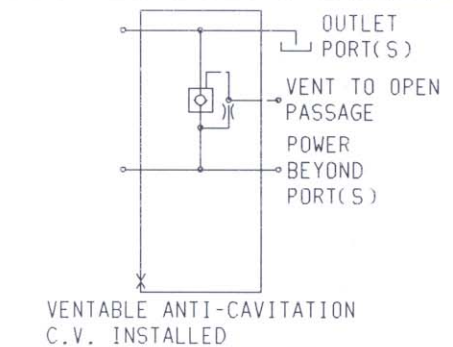
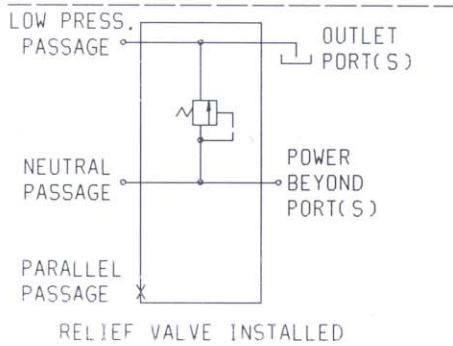

TO CREATE A CLOSED CENTER CIRCUIT, PLUG POWER BEYOND PORT(S) AND INSTALL SHUT-OFF PLUG IN AUXILIARY PORT

WITH 53203 HOLLOW HEX PLUG INSTALLED IN AUXILIARY PORT, ALL PORTS ARE COMMON TO OUTLET

PORT SIZES				OUTLET SECTION PART NUMBER (51055 R.V.)
OUTLET TOP	END	POWER BEYOND TOP	END	
SAE 16	NONE	SAE 12	NONE	6003-D48
SAE 16	SAE 16	SAE 12	SAE 16	6003-D49

USED IN SECTION ③ OF THE VALVE  
ASSEMBLY SPECIFICATION SHEET (Pg 30)

SEE PAGE 7 FOR ADDITIONAL DIMENSIONAL INFORMATION

WEIGHT:  
APPROX. 10 LBS. (4.5 kg)

## Cutaway View and Downstream View (“O” Ring Face) of Inlet End Section Assembly P/N 6001-D102

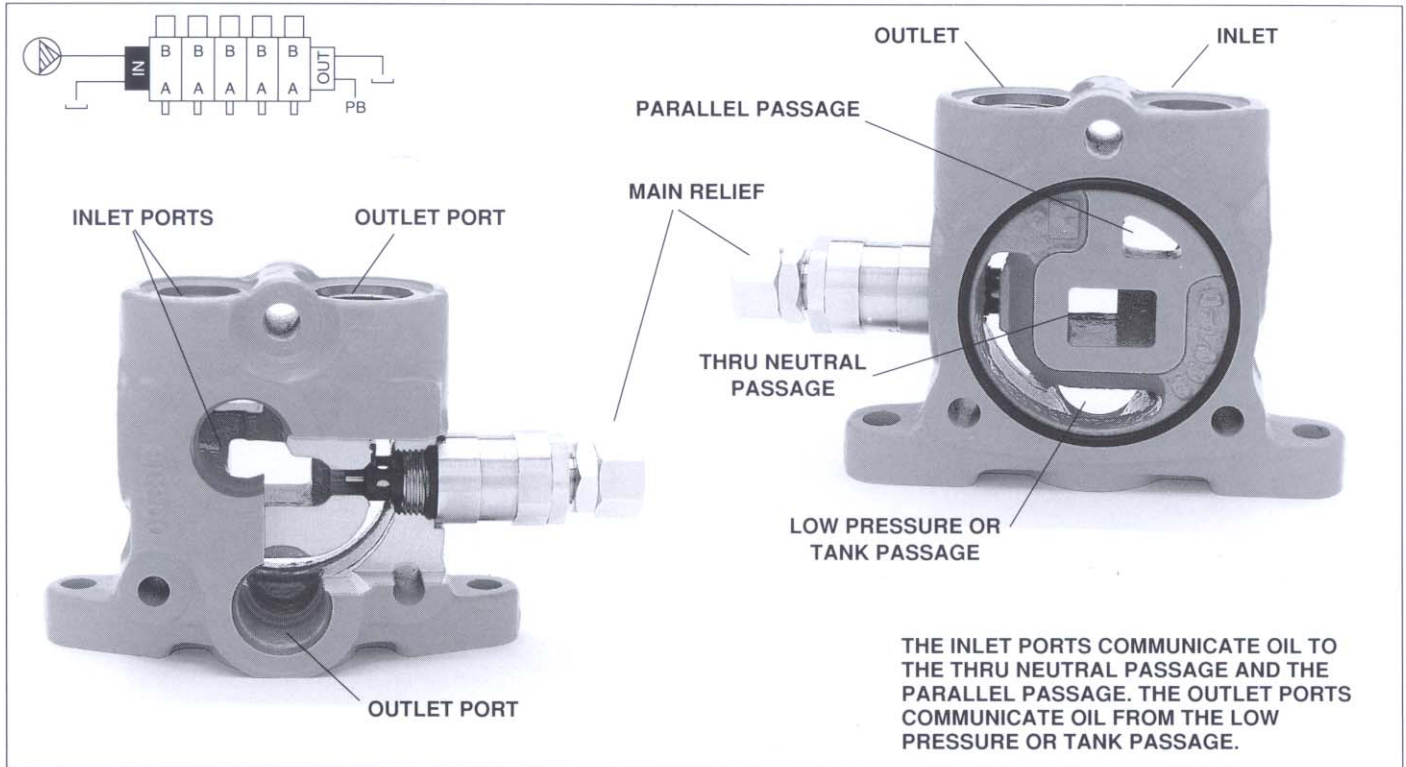

## Cutaway View and Upstream View (Non-“O”-Ring Face) of Outlet End Section Assembly P/N 6003-D49

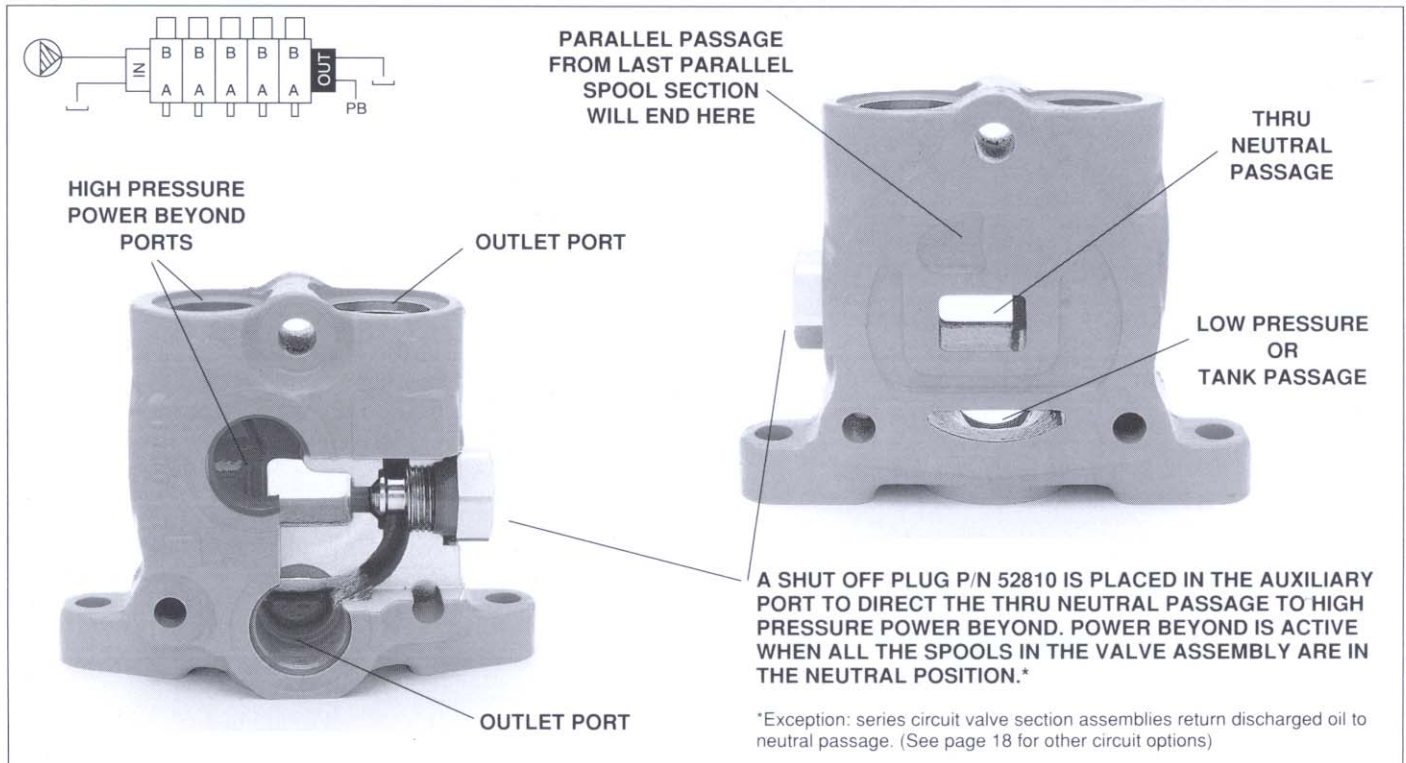

# RELIEF VALVE ASSEMBLIES

## HIGH PERFORMANCE P.O. RELIEF VALVE

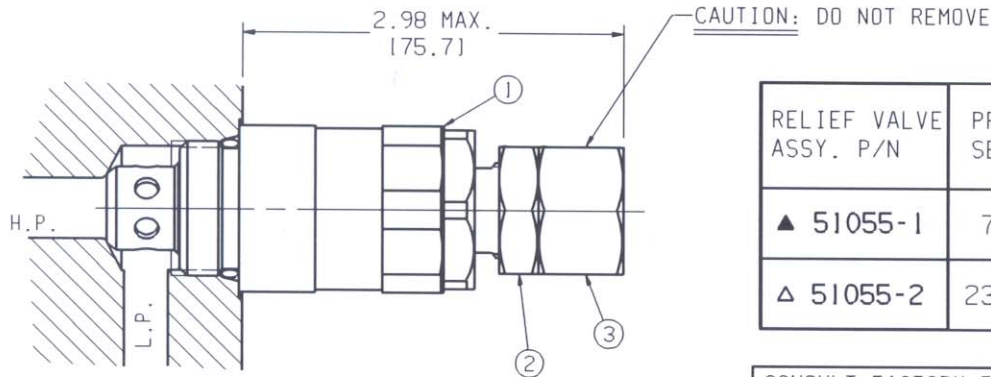

TORQUE MAIN BODY #1 INTO VALVE HOUSING USING 43 - 53 FT.-LBS.

TO ADJUST PRESSURE SETTING, LOOSEN JAM NUT #2. TURN ADJUST SCREW #3 TO DESIRED SETTING. RE-TIGHTEN JAM NUT USING 29.5 - 36.5 FT.-LBS.

RELIEF VALVE ASSY. P/N	PRESSURE SETTING RANGE:
▲ 51055-1	700-2700 PSI
△ 51055-2	2300-4300 PSI

CONSULT FACTORY FOR 51055 STYLE RELIEFS TO 5500 PSI

- ▲ FACTORY SET AT 2000 PSI AT 5 GPM
- △ FACTORY SET AT 2500 PSI AT 5 GPM

APPROX. ADJUSTMENT VALUES:  
51055 STYLE - 400 PSI PER 1/4 TURN

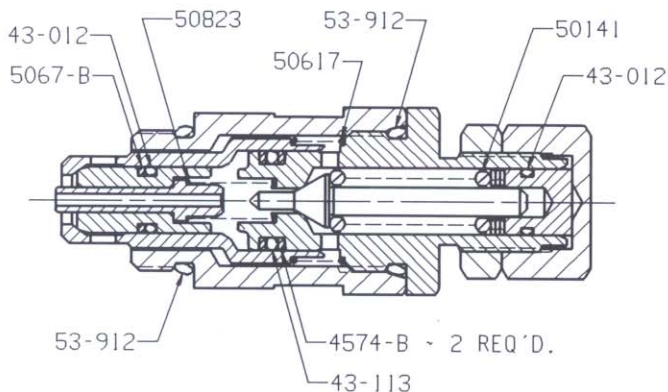
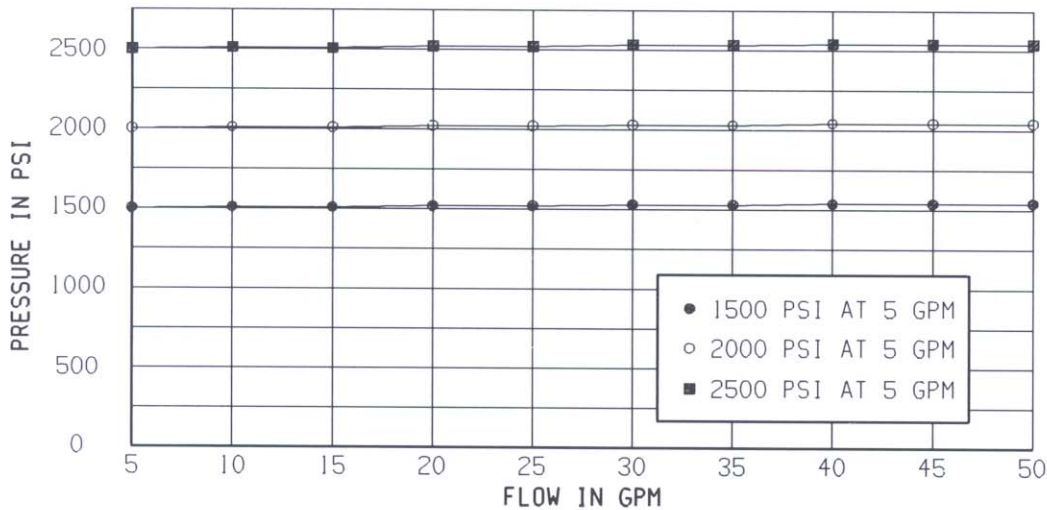

SPRING & SEAL KIT 51799-1		
PART NO.	DESCRIPTION	QTY.
43-012	O-RING	2
43-113	O-RING	1
53-912	O-RING	2
4574-B	BACK-UP RING	2
5067-B	BACK-UP RING	1
50141	SPRING	1
50617	SPRING	1
50823	SPRING	1

# AUXILIARY VALVE AND TIE ROD INFORMATION

## ANTI-CAVITATION CHECK VALVE

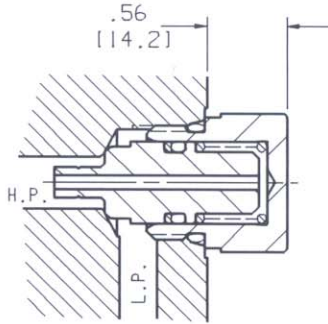

THE ANTI-CAVITATION CHECK VALVE OPENS WHEN L.P. PASSAGE PRESSURE EXCEEDS THE H.P. PASSAGE PRESSURE.

R.V. STYLE	P/N:	TORQUE
51055	5375-F	43-53 FT-LBS

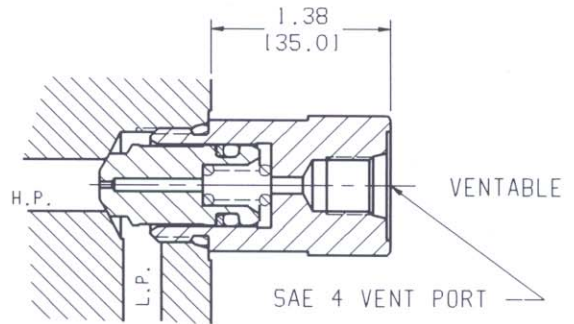

THE VENTABLE ANTI-CAVITATION CHECK VALVE OPENS WHEN THE L.P. PASSAGE PRESSURE EXCEEDS THE H.P. PASSAGE PRESSURE OR WHEN THE VENT PORT IS OPENED TO TANK.

R.V. STYLE	P/N:	TORQUE
51055	5375-H	43-53 FT-LBS

## SHUT-OFF PLUG ASSEMBLY

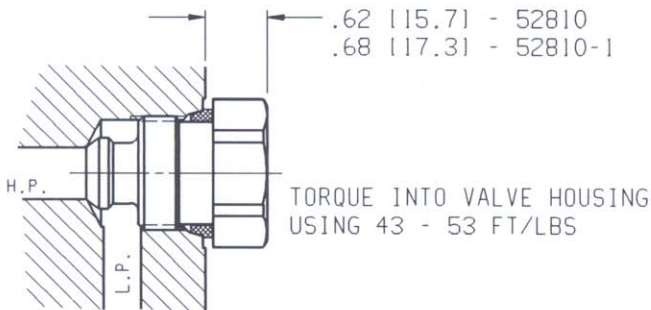

THE SHUT-OFF PLUG IS USED TO SHUT-OFF THE L.P. PASSAGE FROM THE H.P. PASSAGE IN ALL THE AUX. VALVE PORTS. IT IS USED TO PLUG THE AUX. VALVE PORT WHEN AN AUXILIARY VALVE IS NOT REQUIRED. THE SHUT-OFF PLUG IS ALSO USED IN THE OUTLET SECTION TO ACTIVATE THE POWER BEYOND PORT(S).

R.V. STYLE	P/N:	TORQUE
51055	52810	43-53 FT-LBS

## MODEL 6000 TIE ROD KITS

P/N:	NO OF SECTIONS
6246-41	1
6246-42	2
6246-43	3
6246-44	4
6246-45	5
6246-46	6
6246-47	7
6246-48	8
6246-49	9

## STANDARD SAE PLUG AND O-RING

DESCRIPTION	P/N:	TORQUE
#12 SAE	11210	66-82 FT-LBS
#12 SAE **	11215	66-82 FT-LBS
#16 SAE	11270	94-116 FT-LBS

\*\* HAS #6 SAE GAGE PORT

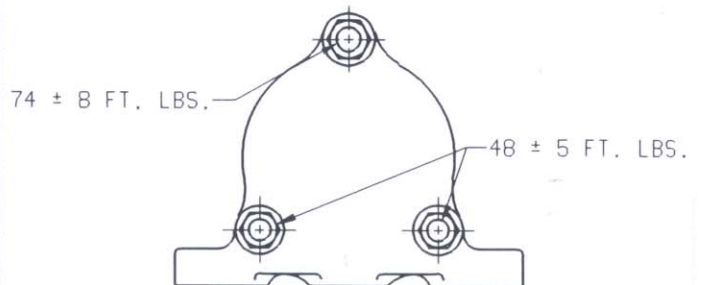

TIE ROD HOLE PATTERN

TORQUE - ANY QTY. OF SECTIONS

# LEVER ASSEMBLIES

## HEAVY DUTY LEVER

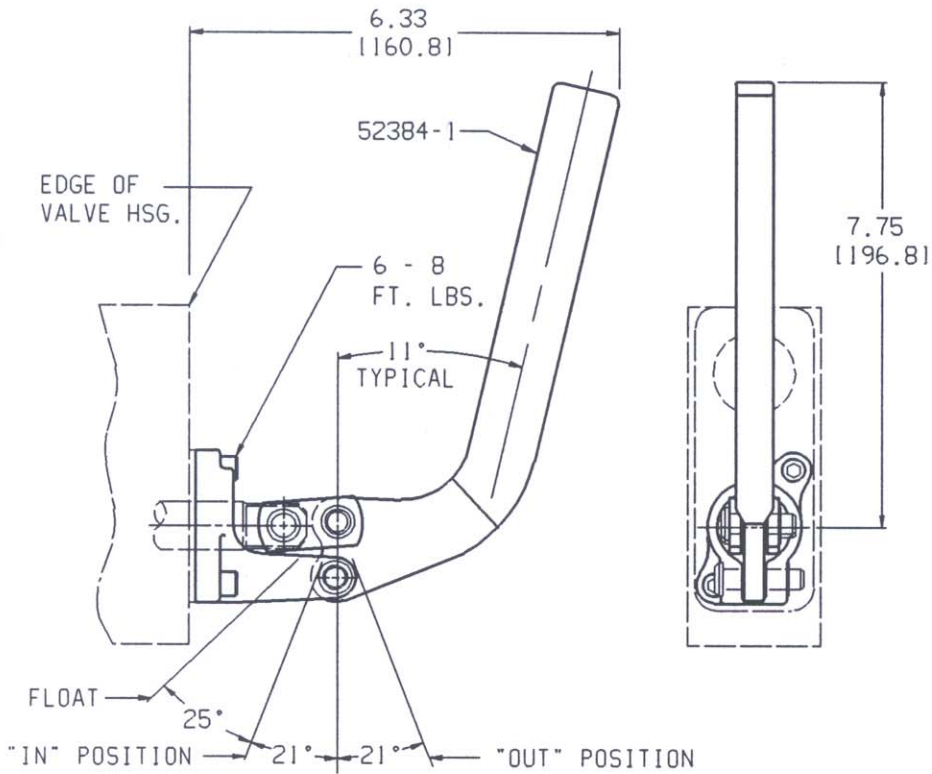

PART NUMBER 6105-1
LEVER ASSY. AS SHOWN

PART NUMBER 6105-C
LESS LEVER P/N 52384-1

## LEVER WITH BOOT

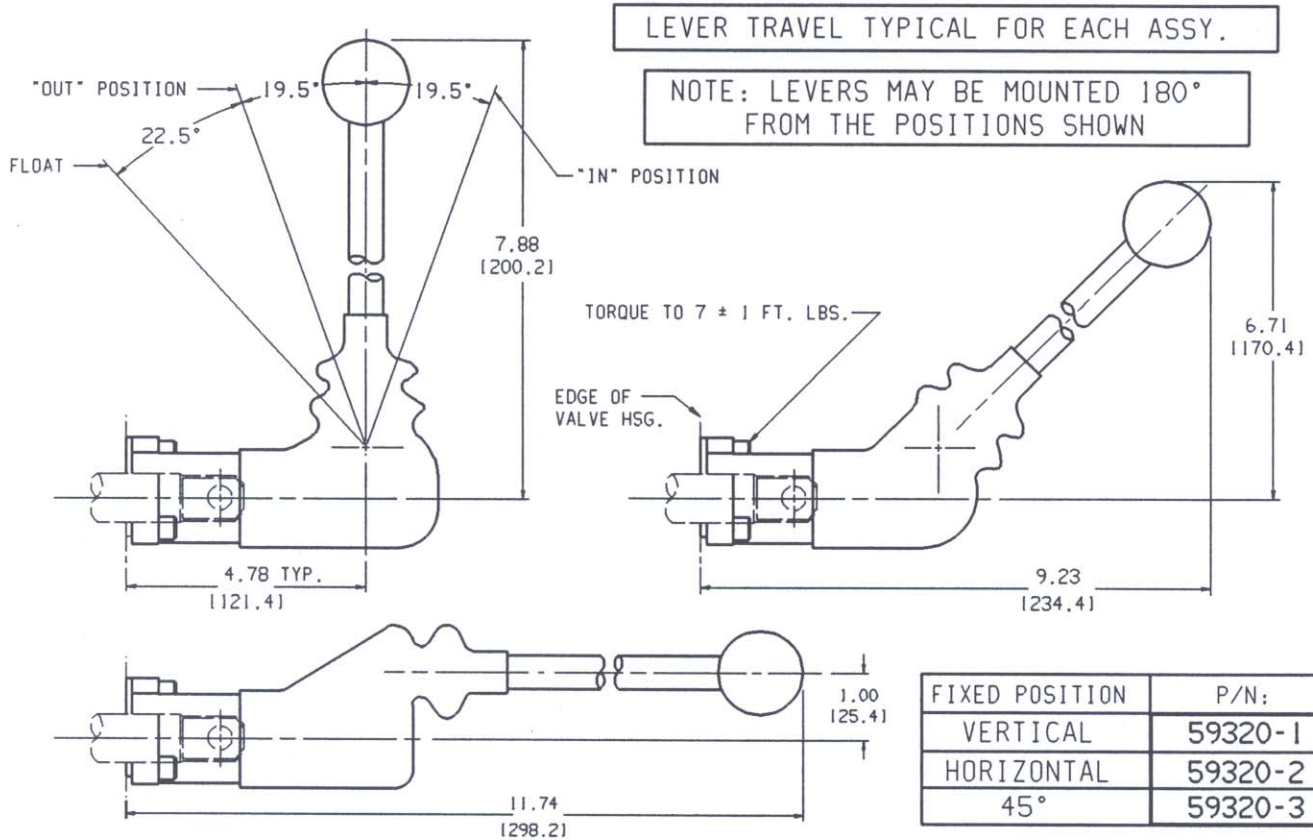

LEVER TRAVEL TYPICAL FOR EACH ASSY.

NOTE: LEVERS MAY BE MOUNTED 180° FROM THE POSITIONS SHOWN

FIXED POSITION	P/N:
VERTICAL	59320-1
HORIZONTAL	59320-2
45°	59320-3

# END MECHANISM KITS

FOR PARALLEL AND CONVENTIONAL CIRCUIT SECTIONS

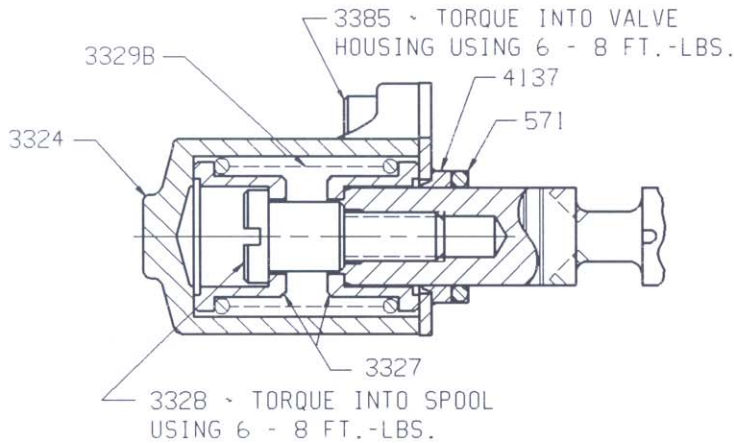

3 POSITION, 4 WAY  
DOUBLE ACTING SPRING CENTERED

**KIT #D10-200**

PART NO.	DESCRIPTION	QTY.
571	O-RING	1
3324	CAP	1
3326	SEALPLATE	1
3327	SPRING SEAT	2
3328	SCREW	1
3329B	SPRING	1
3385	CAP SCREW	2
4137	WIPER	1

FOR SERIES CIRCUIT SECTIONS USE: KIT #D10-104 (P/N 4156 AND 4159 REPLACE P/N 3328)

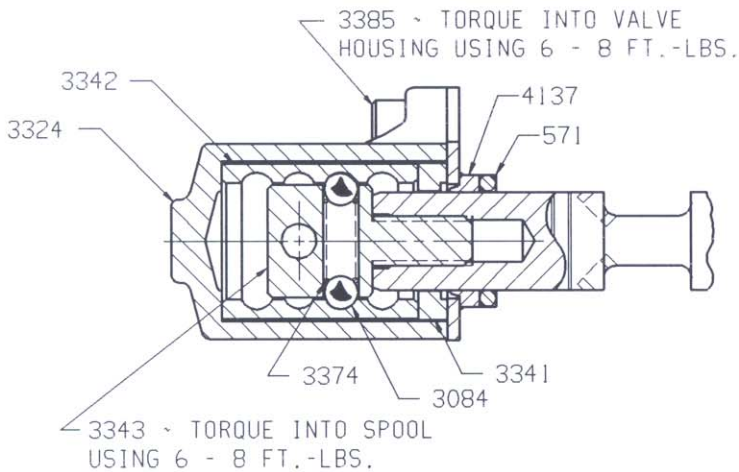

3 POSITION, 4 WAY  
DOUBLE ACTING DETENT

**KIT #D11-100**

PART NO.	DESCRIPTION	QTY.
571	O-RING	1
3084	BALL	2
3324	CAP	1
3326	SEALPLATE	1
3341	SPACER	1
3342	DET. SLEEVE	1
3343	DET. PIN	1
3374	SPRING	1
3385	CAP SCREW	2
4137	WIPER	1

FOR SERIES CIRCUIT SECTIONS USE: KIT #D11-116 (P/N 51509 AND 4159 REPLACE P/N 3343)

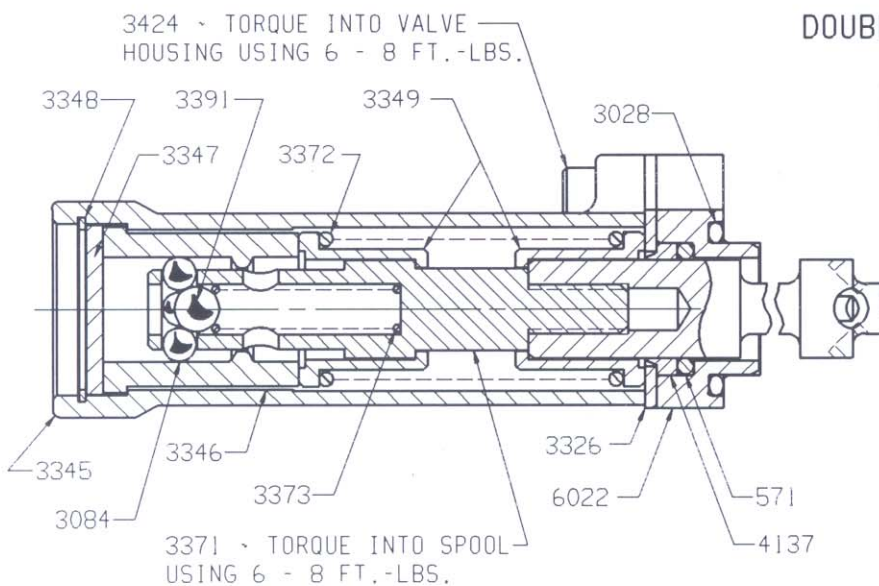

4 POSITION, 4 WAY  
DOUBLE ACTING SPRING CENTERED  
DETENT IN FLOAT

**KIT #D11-204**

(NOT FOR CONVERSION)

PART NO.	DESCRIPTION	QTY.
571	O-RING	1
3028	O-RING	1
3084	BALL	4
3326	SEALPLATE	1
3345	CAP	1
3346	DET. SLEEVE	1
3347	DET. PLUG	1
3348	SNAP RING	1
3349	SPRING SEAT	2
3371	DET. PIN	1
3372	SPRING	1
3373	SPRING	1
3391	BALL	1
3324	CAP SCREW	2
4137	WIPER	1
6022	SPACER	1

# END MECHANISM KITS

- NOT FOR SERIES SECTIONS -

## HYDRAULIC REMOTE (OIL PILOT OPERATED)

**KIT P/N: D12-109**

PILOT PRESSURE RANGE:

18 PSI TO BEGIN SPOOL SHIFT -  
390 PSI TO COMPLETE SPOOL SHIFT

PART NO.	DESCRIPTION	QTY.
3285	O-RING	1
3385	CAP SCREW	2
41-020	O-RING	2
52072	SPRING	1
53346	SPACER	1
53347	WASHER	2
53351	SHLDR. SCREW	2
55000	RETAINER	2
55001	CAP	1
55003-5	CAP	1
55119	CAP SCREW	2
55251	RETAINER	1

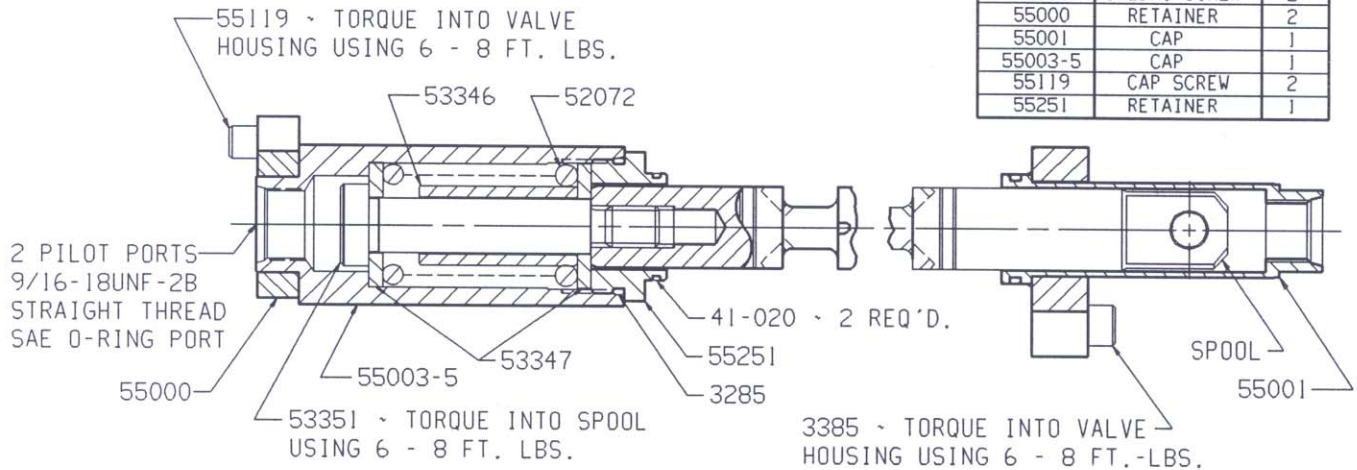

FOR SERIES CIRCUIT SECTIONS USE: KIT #D12-110

## PNEUMATIC REMOTE (AIR PILOT OPERATED)

**KIT P/N: 54702**

PILOT PRESSURE RANGE:

THIS CHART IS SPRING FORCE ONLY	START TO SHIFT PSI	FULL SHIFT PSI
BASE SIDE STROKE "OUT"	30 PSI	55 PSI
ROD SIDE STROKE "IN"	34 PSI	62 PSI

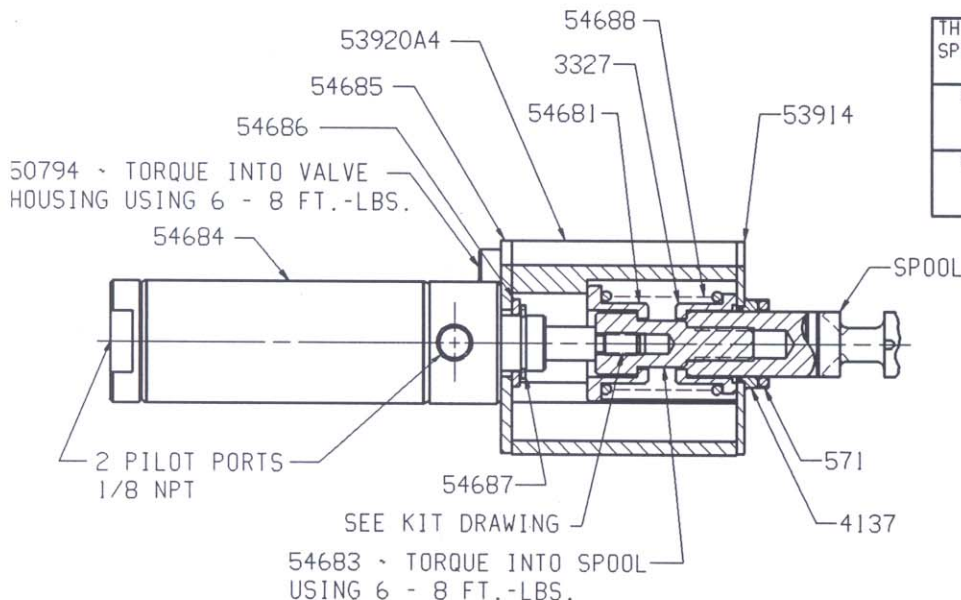

PART NO.	DESCRIPTION	QTY.
571	O-RING	1
3327	SPRING SEAT	1
4137	WIPER	1
50794	CAP SCREW	2
53914	SEAL PLATE	1
53920-A4	CAP	1
54681	SPRING SEAT	1
54683	SPOOL END	1
54684	AIR ACTUATOR	1
54685	CAP	1
54686	WASHER	1
54687	RET. RING	1
54688	SPRING	1
	KIT-DRG.	1



## AUTOMATIC KICKOUT FEATURE

The auto-kickout feature, more commonly used and available on conventional circuit spool section assemblies (page 14), is an optional spool end mechanism. The auto-kickout mechanism combines a spring centered mechanism with a spool dented "in" and "out" mechanism that will release the spool to the center position at a pre-determined settable cylinder port pressure.

The illustration below identifies the working components of the auto-kickout mechanism. The auto-kickout mechanism is not available in kit conversion form because it requires a special valve section housing for its operation. Consult HUSCO for disassembly and reassembly maintenance procedures.

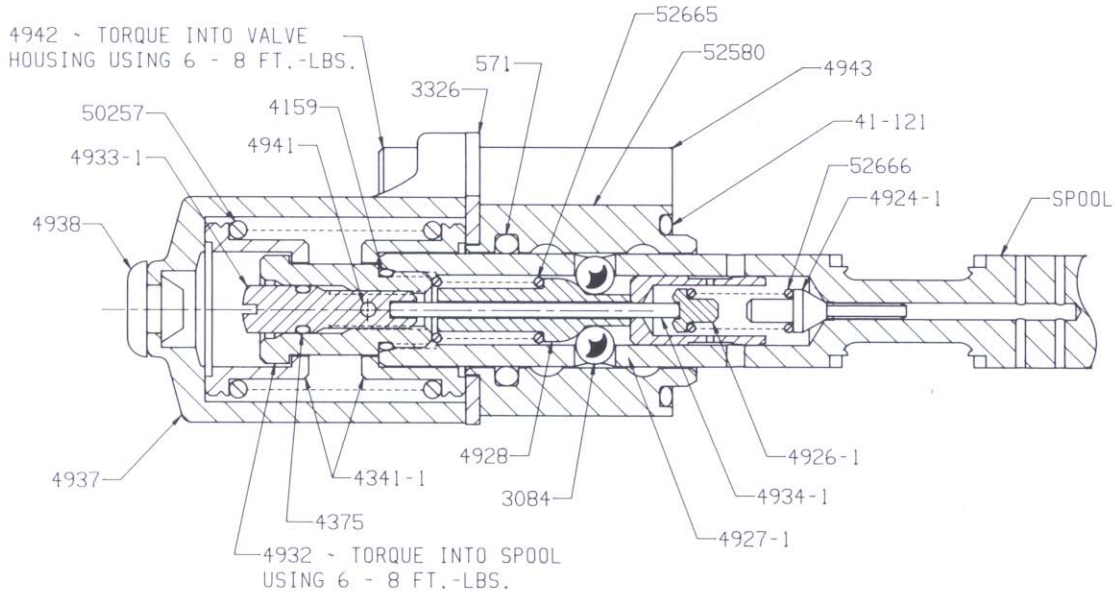

PART NO.	DESCRIPTION	QTY.
41-121	O-RING	1
571	O-RING	1
3084	BALL	2
3326	SEALPLATE	1
4159	O-RING	1
4341-1	SPRING SEAT	2
4375	O-RING	1
4924-1	POPPE	1
4926-1	SPRING GUIDE	1
4927-1	SLEEVE	1
4928	DET. CAM	1
4932	SPOOL END	1

PART NO.	DESCRIPTION	QTY.
4933-1	ADJUST SCREW	1
4934-1	ADJUST ROD	2
4937	CAP	1
4938	PLUG	1
4941	LOCKING INSERT	1
4942	CAP SCREW	2
4943	SPACER	2
50257	SPRING	1
52580	DET. SLEEVE	1
52665	SPRING	1
52666	SPRING	1

### Auto-Kickout Setting and Adjustment

Adjustments to the auto-kickout valve section are made when integrated within a hydraulic circuit.

- 1 Install a pressure gage in the valve assembly inlet or a cylinder port line which is in communication with the auto-kickout valve section to be adjusted.
- 2 With the hydraulic system off, shift auto-kickout valve section to a detented position.
- 3 Activate the hydraulic system at a reduced pressure below that of the desired setting. Let the cylinder bottom out or plug the cylinder port to allow pressure build-up for kickout activation. Slowly increase the hydraulic system pressure (the main system relief may be used for the purpose) until the auto-kickout activates and the spool returns to the center neutral position. **Do not exceed system capability.** Note the pressure reading at time of kickout; this will determine its current setting. Standard factory setting, if not specified, is 2000 PSI.
- 4 To make adjustments, remove rubber plug (P/N 4938) from end cap to access adjustment screw (P/N 4933-1). With hydraulic system off, turn adjustment screw clockwise (in) to increase the pressure setting, counterclockwise (out) to decrease pressure setting. One revolution of the adjustment screw is approximately equal to 650 PSI change in the kickout pressure. Repeat Procedure #3 above until desired setting is achieved. Adjustment range is 1000-2600 PSI. Run a few cycles to assure setting consistency, replace rubber plug. Note: Final main relief setting must be at least 250 PSI higher than the highest auto-kickout setting in the system.

Caution: To avoid damaged or lost parts do not remove adjustment screw.

(For reference, the adjustment screw has approximately 15 full turns of thread engagement before it "bottoms out." The kickout adjustment range is within the last 5 full turns before the "bottom out" condition occurs.)

# SPOOL END ORIENTATION

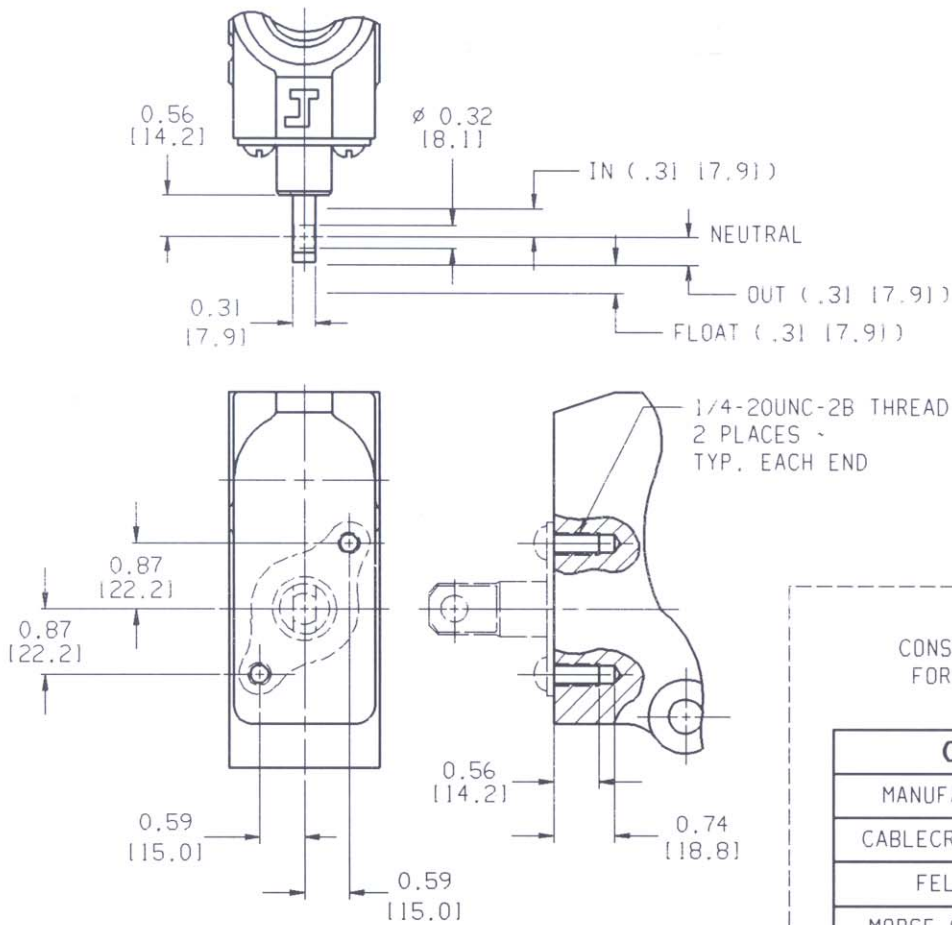

CONSULT CABLE MANUFACTURER  
 FOR FURTHER INFORMATION

CABLE CONNECTORS	
MANUFACTURER	KIT P/N
CABLECRAFT INC.	180-100-002
FELSTED	59103
MORSE CONTROLS	303031

# BASIC CASTING IDENTIFICATION

(NON-SERVICEABLE)

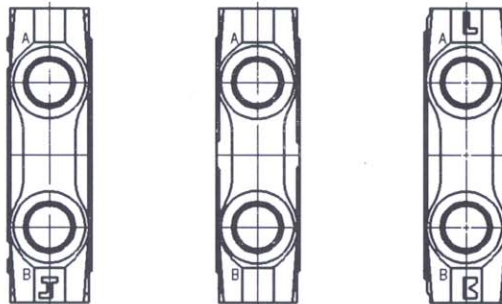

NOTE:  
 CASTING OPTIONS SHOWN  
 ARE REPRESENTED IN THIS  
 CATALOG.  
 CONTACT HUSCO FOR OTHER  
 AVAILABLE OPTIONS.

SECTION ASSY. BASE No. (REF. ONLY)	6002J	6002K	6002W
CASTING BASE No. (REF. ONLY)	6005J	6005K	6005W
IRON TYPE	GREY	GREY	GREY
CIRCUIT	PARALLEL R.H.	CONVENTIONAL R.H.	CONVENTIONAL L.H.

# SERVICE INFORMATION

## HUSCO COMBINATION WORK

### PORT RELIEF AND ANTI-VOID UNIT

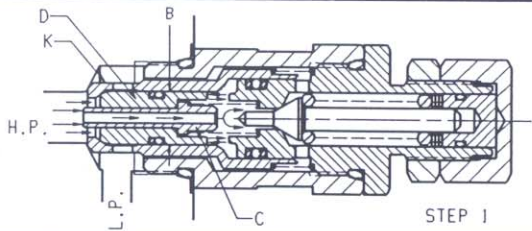

STEP 1

#### AS WORK PORT RELIEF

The relief valve is in communication between the high pressure port "HP" and low pressure "LP". Oil is admitted through the hole in poppet "C" and because of the differential area between diameters "A" and "B" relief valve poppet "D" and check valve poppet "K" are tightly seated as shown in the first step.

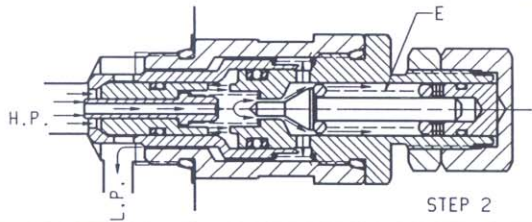

STEP 2

The oil pressure in the high pressure port "HP" has reached the setting of the pilot poppet spring force and unseats the pilot poppet "E" and oil flows around the poppet - through the cross drilled holes and to the low pressure area "LP".

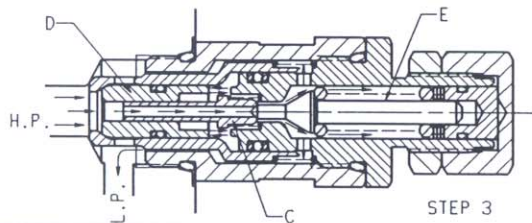

STEP 3

The loss of oil behind Poppet "C", effected by the opening of pilot poppet "E", causes poppet "C" to move back and seat against pilot poppet "E". This shuts off the oil flow to the area behind relief valve poppet "D", and causes a low pressure area internally.

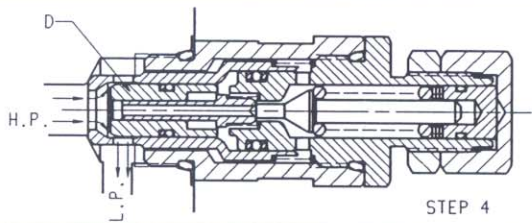

STEP 4

The imbalance of pressure on the inside as compared to that of the high pressure port "HP", forces the relief valve poppet "D" to open and relieve the oil directly to the low pressure chamber "LP" in the valve.

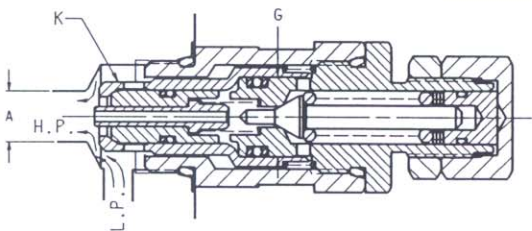

#### AS ANTI-VOID

The anti-void unit supplies oil to the high pressure port "HP" when cavitation has occurred. A lower pressure exists in the port "HP" compared to the low pressure chamber "LP". The difference between the effective area of diameter "A" and "G" causes imbalance of the check valve poppet "K" which unseats, thus allowing oil from the low pressure chamber "LP" to enter the port "HP" and fill the void.

#### AS SEPARATE ANTI-VOID

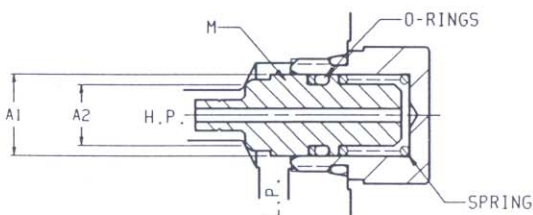

The anti-void check valve opens when cavitation occurs in the high pressure port "HP" and supplies oil from the reservoir "LP" to help fill this void. The poppet "M" is held on its seat by the port pressure "HP", acting on the larger area behind the "O" ring. When pressure "HP" drops below atmosphere, the tank pressure "LP" operating on the annular area  $A_1-A_2$  will overcome the port pressure "HP" and the spring force to open the poppet. When the void is eliminated the spring will return the poppet which will then be tightly seated by the port pressure "HP".

Check HUSCO first for modern hydraulic/electro hydraulic components and systems engineered to your specific needs.

**HUSCO**  
International

## MAINTENANCE PROCEDURE FOR HUSCO COMBINATION WORK PORT RELIEF AND ANTI-VOID UNIT

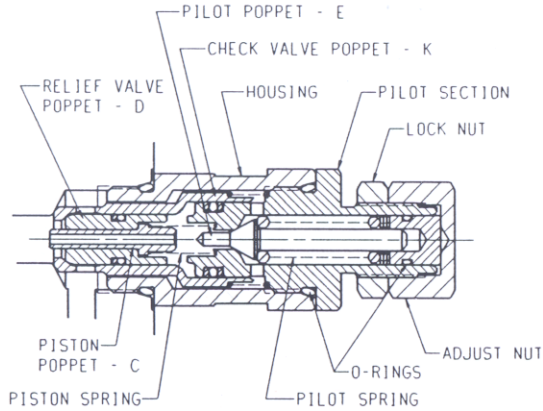

### SERVICE AND REPAIR INFORMATION

The cartridge type work port reliefs used in the HUSCO valves are typically of the pilot poppet type with external adjustment. Any mal-functioning is usually the result of foreign matter lodging between the piston, relief valve poppet, and check valve.

To perform service, clean the surrounding area and remove the complete relief valve cartridge. Examine the seat in the main valve housing and if grooves or ridges are present, the valve must be returned to HUSCO for re-machining.

The design of the pilot poppet and its seat provides positive seating and very seldom requires any maintenance. Therefore, the pilot section can be removed from the cartridge housing without disturbing the setting. With it will come the check valve poppet and other internal parts. These are easily disassembled and should be examined for foreign matter. All seats and seating surfaces should be smooth and free of nicks, scratches or grooves. Examine O-rings and back up washers for any damage and replace if necessary. All moving parts should slide freely, with only seal friction being present.

After inspecting and cleaning, immerse all parts in hydraulic oil and re-assemble. Since pressure setting was not disturbed, unit can be tested for proper functioning under actual working conditions.

If operating difficulties indicate that the pilot poppet is leaking or sticking, remove internal parts of the pilot section, and follow the same procedure as above plus follow "How to Set Pressure" previously discussed.

If unit still does not function properly, you may wish to return the cartridge to HUSCO.

There are several variations to the Work Port Relief. However all are similar in nature regarding service and repair.

### HOW TO SET PRESSURE ON WORK PORT RELIEF

A good pressure gage must be installed in the line which is in communication with the work port relief. A load must be applied in a manner to reach the set pressure of the port relief unit. Then, follow these steps:

- Loosen lock nut.
- Set adjusting nut to desired pressure setting
- If desired pressure setting cannot be achieved, add or remove shims as required
- Tighten lock nut.
- Retest in similar manner as above.

The Void Control Feature is not adjustable but is designed to operate whenever the work port pressure is lower than the reservoir pressure.

DIFFICULTY	PROBABLE CAUSE	REMEDY
Can't get Pressure	Poppet D, E or K stuck open or contamination under seat.	Check for foreign matter between poppets D, E or K and their mating parts. Parts must slide freely.
Erratic Pressure	Pilot poppet seat damaged. Poppet C sticking in D.	Replace the relief valve. Clean and remove surface marks for free movement.
Pressure setting not correct	Normal wear. Lock nut & adj. screw loose.	See "How to set pressure on work port relief."
Leaks	Damaged seats. Worn O-rings. Parts sticking due to contamination.	Replace the relief valve. Install seal and spring kit. Disassemble and clean.

### TROUBLE SHOOTING - ANTI-VOID

Trouble resulting in malfunctioning can usually be traced to foreign matter plugging the sensing hole or preventing free movement of poppet. Also check seat for scratches, nicks or other marks.

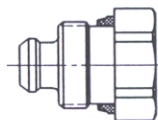

### SHUT-OFF VALVE

Shut-off valves are available to fit most work port and main relief valve machining locations.

**HUSCO International**  
W239N218 Pewaukee Rd. Waukesha, WI 53188  
Phone (262)513-4325 Fax(262)513-4427

Authorized Permission For Reprinting Must Be Granted From HUSCO.

GFI-3M0593

## ASSEMBLY PROCEDURES FOR THE HUSCO 6000 VALVE

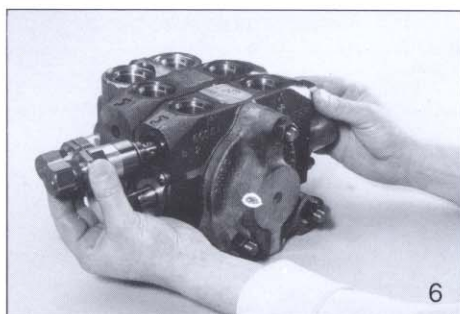
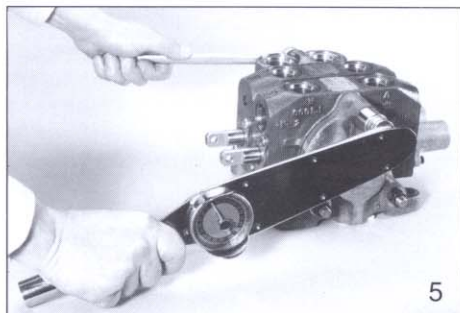
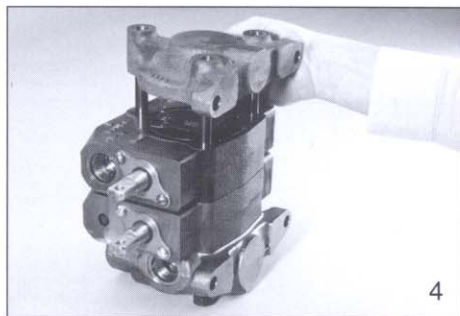
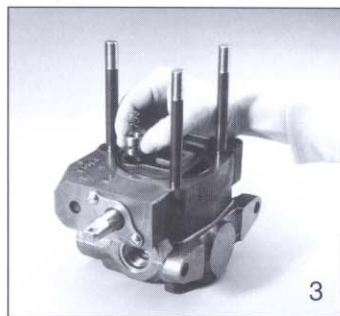
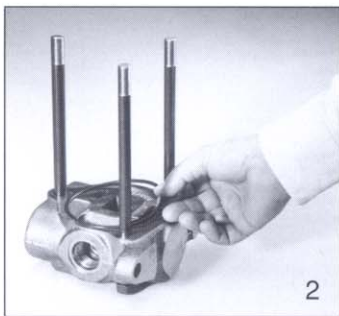
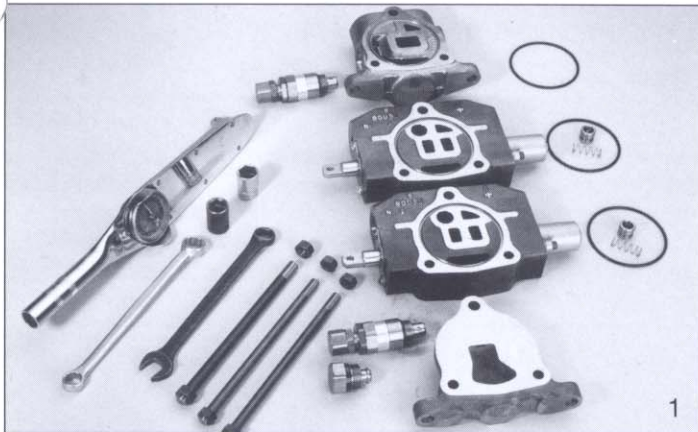

1. Lay out valve components on a clean, flat working surface. The inlet assembly will include an "o" ring, and the spool section(s) include an "o" ring, a load check poppet and a load check spring. Tools required for basic valve assembly include 3/4 and 11/16 open or box end wrenches and a torque wrench with thin wall sockets.

2. Assemble tie rod nuts to one end of each tie rod with one or two threads showing. Insert tie rods through tie rods through tie rod holes of inlet (larger tie rod at top). Lay inlet on end with tie rods up, place "o" ring into position.

3. Place first spool section ("o" ring side up) on inlet section, position "o" ring and insert load check poppet (nose down) and spring (behind poppet) into load check cavity as shown. Repeat this procedure for each spool section; the load check springs are compressed by the following sections during assembly.

4. Position end section on last spool section as shown and hand tighten tie rod nuts. The end section on picture is a "turn around" section without ports, (pg. 16). Universal outlet / power beyond section (pg. 18) and power beyond and closed center sections (pg. 17) are also used as end sections. These end sections do not have "o" ring grooves.

5. Position valve assembly with the mounting pads of the end sections on a flat surface. To obtain proper alignment of end sections relative to the spool sections apply downward pressure to the end sections; snug tie rod nuts to about 10 ft lbs.

Final torque the two 11/16 nuts to 48+/-5 ft lbs; final torque the 3/4 nut to 74+/-8 ft lbs. Check for proper spool movement.

6. Install auxiliary valves and plugs and torque to proper specifications.

### General assembly notes:

- A. Lever assemblies can be installed on section before or after complete valve assembly.
- B. The load check and spring may be omitted from assembly in certain circuit conditions (i.e., motor spools).

**MODEL 6000 SECTIONAL VALVE ASSEMBLY SPECIFICATION SHEET**

CUSTOMER: \_\_\_\_\_ CUSTOMER P/N: \_\_\_\_\_  
 MACHINE TYPE: \_\_\_\_\_ MACHINE MODEL: \_\_\_\_\_  
 ESTIMATED ANNUAL USAGE: \_\_\_\_\_ SUBMITTED BY: \_\_\_\_\_ DATE: \_\_\_\_\_  
 OPERATING PRESSURE: \_\_\_\_\_ INLET FLOW: \_\_\_\_\_ MID-INLET FLOW: \_\_\_\_\_

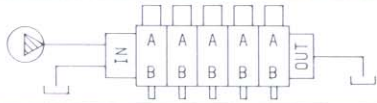

**4** AUXILIARY VALVES

**5** LEVERS

**SECTIONS**

AUX. "A"

AUX. "B"

ASSEMBLY P/N

①	INLET END COVER	6001- _____	P/N: _____ PSI: _____	INLET END COVER PORT PLUGS <small>SEE LISTING OF PLUG P/N'S BELOW</small> TOP IN: _____ TOP OUT: _____ END IN: _____ END OUT: _____		
OR MID-INLETS	FUNCT: _____ TIE-ROD KIT 6246-41	600 __ - _____	P/N: _____ PSI: _____	P/N: _____ PSI: _____		
	FUNCT: _____ TIE-ROD KIT 6246-42	600 __ - _____	P/N: _____ PSI: _____	P/N: _____ PSI: _____		
	FUNCT: _____ TIE-ROD KIT 6246-43	600 __ - _____	P/N: _____ PSI: _____	P/N: _____ PSI: _____		
	FUNCT: _____ TIE-ROD KIT 6246-44	600 __ - _____	P/N: _____ PSI: _____	P/N: _____ PSI: _____		
	SPOOL SECTIONS	FUNCT: _____ TIE-ROD KIT 6246-45	600 __ - _____	P/N: _____ PSI: _____	P/N: _____ PSI: _____	
		FUNCT: _____ TIE-ROD KIT 6246-46	600 __ - _____	P/N: _____ PSI: _____	P/N: _____ PSI: _____	
		FUNCT: _____ TIE-ROD KIT 6246-47	600 __ - _____	P/N: _____ PSI: _____	P/N: _____ PSI: _____	
		FUNCT: _____ TIE-ROD KIT 6246-48	600 __ - _____	P/N: _____ PSI: _____	P/N: _____ PSI: _____	
FUNCT: _____ TIE-ROD KIT 6246-49	600 __ - _____	P/N: _____ PSI: _____	P/N: _____ PSI: _____			
③	OUTLET END COVER	6003- _____	P/N: _____ PSI: _____	OUTLET END COVER PORT PLUGS <small>SEE LISTING OF PLUG P/N'S BELOW</small> TOP P.B.: _____ TOP OUT: _____ END P.B.: _____ END OUT: _____		

COMMENTS:

SAE PLUG ASSY P/N's: 12 SAE - 11210 16 SAE - 11270

TIE ROD TORQUE: LARGE DIA. 74 FT.LBS., SMALL DIA. 48 FT.LBS.