

4000 Series

Highlights

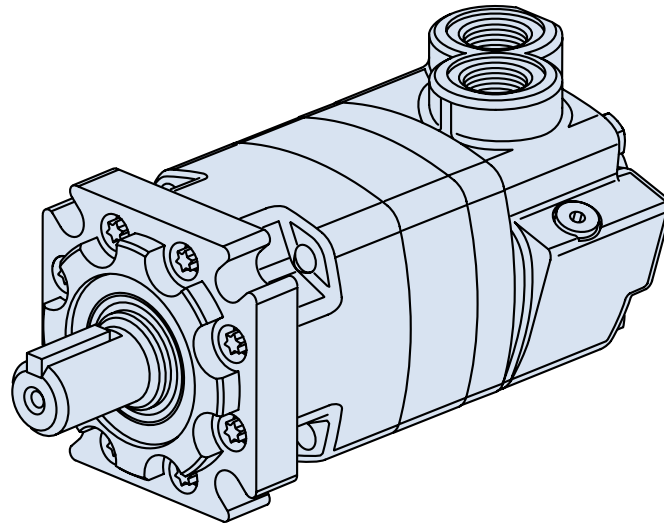

Features

- 10 displacements, a variety of mounting flanges and output shafts
- Reliable, proven design
- High efficiency
- Environmental protection options

Benefits

- Flexibility in designing this motor into a system
- Options that fit well into tough applications

Applications

- Mowing
- Snow Removal
- Sprayer
- Trencher
- Wood Products

Description

The 4000 Series offers up to 8600 in-lb of torque and 25 gpm (continuous ratings). This is the corner stone of the Char-Lynn line.

4000 Series Motors

Geroler Element	10 Displacements
Flow l/min [GPM]	95 [25] Continuous**
	150 [40] Intermittent*
Speed RPM	722 Cont.**
	868 Inter.*
Pressure bar [PSI]	200 [3000] Cont.**
	300 [4500] Inter.*
Torque Nm [lb-in]	970 [8600] Cont.**
	1180 [10450] Inter.*

** Continuous— (Cont.) Continuous rating, motor may be run continuously at these ratings

* Intermittent— (Inter.) Intermittent operation, 10% of every minute.



Mowing



Snow Removal



Sprayer



Trencher

4000 Series

Specifications

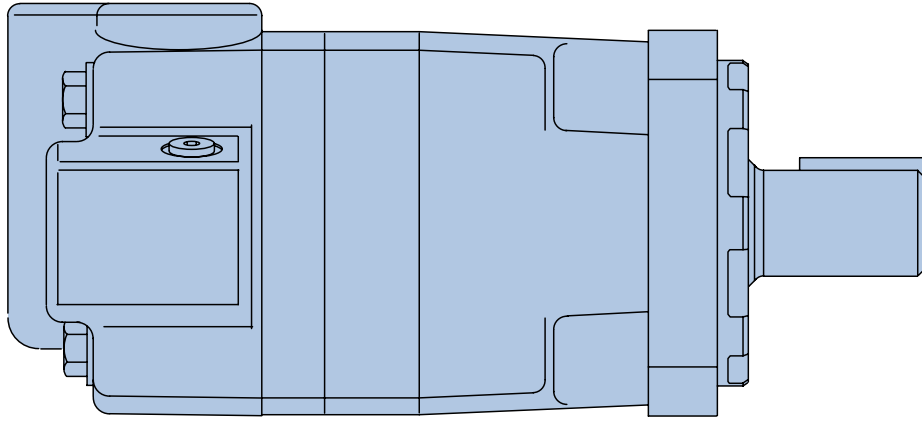

4000 SERIES MOTORS

Displ. cm ³ /r [in ³ /r]		110 [6.7]	130 [7.9]	160 [9.9]	205 [12.5]	245 [15.0]	280 [17.1]	310 [19.0]	395 [24.0]	495 [30.0]	625 [38.0]
Max. Speed (RPM)	Continuous	697	722	582	459	383	336	303	239	191	151
	Intermittent	868	862	693	546	532	488	422	376	305	241
@ Flow											
Flow l/min [GPM]	Continuous	75 [20]	95 [25]	95 [25]	95 [25]	95 [25]	95 [25]	95 [25]	95 [25]	95 [25]	95 [25]
	Intermittent	95 [25]	115 [30]	115 [30]	115 [30]	130 [35]	130 [35]	130 [35]	150 [40]	150 [40]	150 [40]
Torque* Nm [lb-in]	Continuous	320 [2850]	375 [3330]	485 [4290]	600 [5300]	705 [6240]	753 [6666]	850 [7530]	930 [8240]	945 [8375]	970 [8605]
	Intermittent	470 [4160]	560 [4940]	705 [6240]	800 [7100]	845 [7470]	957 [8471]	1065 [9420]	1185 [10470]	1170 [10350]	1180 [10450]
Pressure Δ bar [Δ PSI]	Continuous	205 [3000]	205 [3000]	205 [3000]	205 [3000]	205 [3000]	205 [3000]	205 [3000]	190 [2750]	140 [2000]	115 [1700]
	Intermittent Peak	310 [4500]	310 [4500]	310 [4500]	310 [4500]	310 [4500]	310 [4500]	310 [4500]	240 [3500]	170 [2500]	140 [2000]
Weight kg [lb]	Standard or Wheel Mount	17.9 [39.5]	18.1 [40.0]	18.1 [40.0]	18.4 [40.5]	18.6 [41.0]	19.1 [42.0]	19.5 [43.0]	20.4 [45.0]	21.8 [48.0]	23.1 [51.0]
	Bearingless	14.1 [31.0]	14.3 [31.5]	14.1 [31.0]	14.5 [32.0]	14.7 [32.5]	15.2 [33.5]	15.6 [34.5]	16.6 [36.5]	17.9 [39.5]	19.3 [42.5]

Maximum Case Pressure: See case pressure seal limitation graph.

*See shaft torque ratings for limitations..

Note:

To assure best motor life, run motor for approximately one hour at 30% of rated pressure before application to full load. Be sure motor is filled with fluid prior to any load applications.

Maximum Inlet Pressure:

310 bar [4500 PSI]
Do not exceed Δ pressure rating (see chart above).

Maximum Return Pressure:

310 bar [4500 PSI] with case drain line installed.
Do not exceed Δ pressure rating (see chart above).

Δ bar [Δ PSI] :

The true pressure difference between inlet port and outlet port

Continuous Rating:

Motor may be run continuously at these ratings

Intermittent Operation:

10% of every minute

Peak Operation:

1% of every minute

Recommended Fluids:

Premium quality, anti-wear type hydraulic oil with a viscosity of not less than 70 SUS at operating temperature.

Recommended Maximum System Operating Temp.:

82° C [180° F]

Recommended Filtration:

per ISO Cleanliness Code, 4406: 20/18/13

4000 Series

Performance Data

Motors run with high efficiency in all areas designated with a number for torque and speed. For best motor life select a motor to run with a torque and speed range shown in the light shaded area.

Performance data is typical at 120 SUS. Actual data may vary slightly from unit to unit in production.

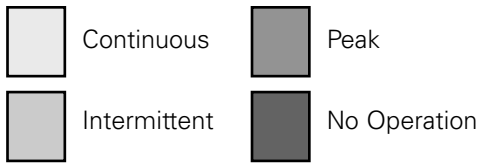

130 cm³/r [7.9 in³/r] Δ Pressure Bar [PSI]

	[250] 15	[500] 35	[1000] 70	[1500] 105	[2000] 140	[2500] 170	[3000] 205	[3500] 240	[4000] 275	[4500] 310
[.5] 1,9	[310] 35 12	[510] 60 9	[1060] 120 5	[1590] 180 2						
[1] 3,8	[290] 35 30	[530] 60 28	[1080] 120 25	[1600] 180 19	[2110] 240 14	[2640] 300 13	[3060] 345 12	[3450] 390 4		
[2] 7,5	[280] 30 57	[530] 60 56	[1100] 125 53	[1620] 185 47	[2140] 240 42	[2660] 300 40	[3180] 360 38	[3600] 405 29	[4020] 455 20	[4080] 460 12
[4] 15	[260] 30 116	[520] 60 114	[1100] 125 111	[1650] 185 105	[2200] 250 100	[2700] 305 95	[3210] 365 90	[3660] 415 70	[4100] 465 50	[4560] 515 37
[6] 23	[240] 25 173	[510] 60 170	[1100] 125 167	[1650] 185 161	[2200] 250 156	[2720] 305 149	[3240] 365 142	[3710] 420 123	[4180] 470 104	[4660] 525 91
[8] 30	[230] 25 228	[510] 60 225	[1080] 120 222	[1640] 185 216	[2210] 250 210	[2740] 310 202	[3270] 370 194	[3770] 425 176	[4270] 480 158	[4750] 535 145
[10] 38	[210] 25 283	[510] 60 281	[1080] 120 278	[1640] 185 272	[2210] 250 266	[2750] 310 256	[3300] 375 246	[3820] 430 229	[4350] 490 212	[4840] 545 189
[12] 45	[200] 25 341	[500] 55 338	[1070] 120 335	[1640] 185 329	[2220] 250 323	[2750] 310 312	[3300] 375 300	[3840] 435 282	[4370] 495 263	[4870] 550 237
[14] 53	[180] 20 400	[490] 55 396	[1060] 120 392	[1640] 185 386	[2220] 250 380	[2750] 310 368	[3310] 375 355	[3860] 435 335	[4390] 495 315	[4890] 550 286
[16] 61	[160] 20 457	[490] 55 453	[1050] 120 449	[1630] 185 443	[2220] 250 437	[2760] 310 424	[3310] 375 410	[3860] 435 388	[4400] 495 366	[4920] 555 335
[18] 68	[130] 15 516	[480] 55 511	[1050] 120 506	[1630] 185 500	[2220] 250 494	[2760] 310 480	[3320] 375 465	[3870] 435 442	[4420] 500 418	[4940] 560 384
[20] 76	[110] 10 574	[470] 55 569	[1040] 120 564	[1620] 185 559	[2210] 250 551	[2760] 310 536	[3330] 375 520	[3890] 440 495	[4440] 500 470	
[22] 83	[70] 10 633	[450] 50 628	[1020] 115 624	[1610] 180 615	[2190] 245 606	[2750] 310 590	[3320] 375 573	[3880] 440 547	[4440] 500 520	
[25] 95	[50] 5 722	[430] 50 718	[1000] 115 714	[1580] 180 702	[2160] 245 690	[2720] 305 672	[3300] 375 653	[3860] 435 625	[4430] 500 595	
[30] 114		[400] 45 862	[940] 105 855	[1500] 170 842	[2080] 235 827	[2670] 300 806	[3200] 360 783	[3740] 425 749		

110 cm³/r [6.7 in³/r] Δ Pressure Bar [PSI]

	[250] 15	[500] 35	[1000] 70	[1500] 105	[2000] 140	[2500] 170	[3000] 205	[3500] 240	[4000] 275	[4500] 310
[.5] 1,9	[150] 15 14	[390] 45 10	[850] 95 5	[1290] 145 2						
[1] 3,8	[170] 20 34	[440] 50 33	[900] 100 31	[1380] 155 28	[1860] 210 25	[2270] 255 22	[2680] 305 18	[3110] 350 11		
[2] 7,5	[180] 20 68	[450] 50 67	[910] 105 62	[1390] 155 56	[1860] 210 50	[2280] 260 44	[2700] 305 36	[3120] 355 28	[3450] 390 18	
[4] 15	[190] 20 138	[460] 50 136	[940] 105 123	[1400] 160 110	[1870] 210 97	[2310] 260 84	[2730] 310 70	[3140] 355 56	[3560] 400 42	[3880] 440 28
[6] 23	[200] 25 207	[470] 55 204	[960] 110 200	[1420] 160 193	[1880] 210 184	[2320] 260 174	[2760] 310 163	[3200] 360 150	[3640] 410 136	[3950] 455 121
[8] 30	[190] 20 277	[460] 50 274	[950] 105 270	[1420] 160 262	[1880] 210 253	[2340] 265 241	[2790] 315 228	[3230] 365 213	[3670] 415 196	[4010] 455 179
[10] 38	[180] 20 347	[460] 50 344	[950] 105 340	[1420] 160 331	[1890] 215 322	[2350] 265 308	[2820] 320 292	[3260] 370 274	[3700] 420 255	[4070] 460 236
[12] 45	[160] 20 417	[450] 50 414	[940] 105 410	[1420] 160 400	[1880] 210 390	[2350] 265 374	[2820] 320 355	[3260] 370 335	[3710] 420 313	[4080] 460 292
[14] 53	[140] 15 487	[440] 50 484	[930] 105 480	[1420] 160 469	[1880] 210 458	[2350] 265 440	[2830] 320 419	[3280] 370 446	[3730] 420 471	[4110] 465 348
[16] 61	[130] 15 556	[440] 50 553	[920] 105 549	[1410] 160 537	[1870] 210 525	[2350] 265 505	[2840] 320 482	[3300] 375 455	[3750] 425 428	[4120] 465 404
[18] 68	[100] 10 626	[440] 50 622	[910] 105 618	[1400] 160 606	[1870] 210 593	[2350] 265 570	[2840] 320 545	[3300] 375 516	[3770] 425 485	[4140] 465 460
[20] 76	[80] 10 697	[430] 50 694	[900] 100 690	[1370] 155 677	[1860] 210 664	[2350] 265 638	[2850] 320 611	[3320] 375 579	[3790] 430 545	[4160] 470 518
[25] 95		[400] 45 868	[860] 95 861	[1350] 155 838	[1850] 210 816	[2320] 260 792	[2830] 320 767	[3300] 375 729	[3780] 425 690	

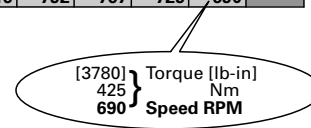

4000 Series

Performance Data

Motors run with high efficiency in all areas designated with a number for torque and speed. For best motor life select a motor to run with a torque and speed range shown in the light shaded area.

Performance data is typical at 120 SUS. Actual data may vary slightly from unit to unit in production.

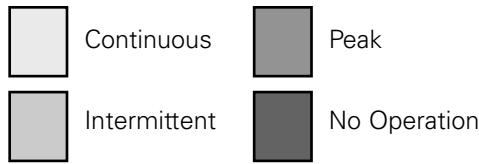

205 cm³/r [12.5 in³/r] Δ Pressure Bar [PSI]

	[250] 15	[500] 35	[1000] 70	[1500] 105	[2000] 140	[2500] 170	[3000] 205	[3500] 240	[4000] 275	[4500] 310
[.5] 1.9	[400] 45 8	[810] 90 5	[1500] 170 1							
[1] 3.8	[410] 45 17	[830] 95 17	[1590] 180 16	[2220] 250 15	[2860] 325 14	[3860] 435 12	[4560] 515 11	[5390] 610 9	[5510] 625 3	
[2] 7.5	[420] 45 36	[850] 95 35	[1680] 190 34	[2410] 270 32	[3140] 355 29	[4060] 460 27	[4800] 540 25	[5420] 610 22	[6000] 680 16	[6210] 700 8
[4] 15	[430] 50 73	[870] 100 73	[1770] 200 71	[2590] 295 70	[3410] 385 68	[4260] 480 61	[5040] 570 57	[5730] 645 45	[6340] 715 35	[6740] 760 23
[6] 23	[430] 50 107	[880] 100 106	[1800] 205 105	[2620] 295 103	[3530] 400 101	[4370] 495 98	[5170] 585 90	[5900] 665 81	[6590] 745 74	[7100] 800 65
[8] 30	[410] 45 144	[870] 100 143	[1820] 205 142	[2660] 300 138	[3560] 400 136	[4410] 500 132	[5240] 590 125	[6020] 680 116	[6770] 765 109	
[10] 38	[390] 45 182	[860] 95 180	[1820] 205 179	[2700] 305 174	[3580] 405 170	[4460] 505 166	[5300] 600 160	[6110] 690 152	[6890] 780 143	
[12] 45	[350] 40 217	[850] 95 216	[1810] 205 215	[2690] 305 211	[3570] 405 202	[4440] 500 200	[5300] 600 194	[6120] 690 185		
[14] 53	[330] 35 256	[840] 95 254	[1790] 200 252	[2670] 300 248	[3560] 400 243	[4430] 500 237	[5290] 600 229	[6120] 690 219		
[16] 61	[290] 35 291	[820] 95 290	[1770] 200 289	[2650] 300 284	[3540] 400 280	[4410] 500 272	[5280] 595 264	[6120] 690 253		
[18] 68	[270] 30 329	[810] 90 327	[1750] 200 325	[2640] 300 321	[3520] 400 316	[4400] 495 308	[5270] 595 298	[6120] 690 287		
[20] 76	[230] 25 366	[800] 90 364	[1730] 195 362	[2620] 295 358	[3510] 395 353	[4380] 495 345	[5270] 595 334	[6120] 690 321		
[22] 83	[190] 20 402	[780] 90 400	[1690] 190 398	[2600] 295 394	[3500] 395 389	[4370] 495 380	[5260] 595 368			
[25] 95	[150] 15 459	[750] 85 456	[1640] 185 453	[2560] 290 448	[3480] 395 442	[4360] 495 434	[5240] 590 421			
[30] 114		[710] 80 546	[1540] 175 542	[2510] 285 537	[3350] 380 529	[4190] 475 520	[5030] 570 504			

160 cm³/r [9.9 in³/r] Δ Pressure Bar [PSI]

	[250] 15	[500] 35	[1000] 70	[1500] 105	[2000] 140	[2500] 170	[3000] 205	[3500] 240	[4000] 275	[4500] 310
[.5] 1.9	[300] 35 8	[680] 75 7	[1320] 150 5	[2050] 230 3	[2750] 310 1					
[1] 3.8	[320] 35 23	[700] 80 22	[1350] 155 20	[2070] 235 19	[2780] 315 18	[3300] 375 16	[3940] 445 15	[4410] 500 8	[4950] 560 2	
[2] 7.5	[330] 35 46	[700] 80 45	[1360] 155 41	[2080] 235 40	[2790] 315 37	[3340] 375 32	[3970] 450 29	[4530] 510 27	[5090] 575 25	[5590] 630 13
[4] 15	[320] 35 93	[710] 80 92	[1400] 160 90	[2100] 240 88	[2820] 320 84	[3420] 385 76	[4020] 455 73	[4620] 520 62	[5220] 590 51	[5730] 645 35
[6] 23	[300] 35 137	[710] 80 135	[1420] 160 134	[2140] 240 131	[2850] 320 126	[3510] 395 120	[4180] 470 114	[4760] 540 90	[5340] 605 75	[5870] 665 57
[8] 30	[280] 30 184	[720] 80 182	[1450] 165 180	[2180] 245 176	[2900] 330 171	[3560] 400 163	[4230] 480 154	[4850] 550 138	[5470] 620 122	[6010] 680 100
[10] 38	[260] 30 232	[720] 80 229	[1480] 165 226	[2220] 250 221	[2950] 335 216	[3610] 410 206	[4290] 485 194	[4920] 555 182	[5560] 630 169	[6160] 695 142
[12] 45	[240] 25 277	[700] 80 274	[1450] 165 272	[2190] 245 266	[2920] 330 260	[3590] 405 250	[4280] 485 238	[4920] 555 224	[5570] 630 209	[6180] 700 182
[14] 53	[220] 25 321	[680] 75 319	[1420] 160 318	[2160] 245 311	[2890] 325 304	[3570] 405 294	[4270] 480 282	[4920] 555 266	[5580] 630 249	[6200] 700 222
[16] 61	[200] 25 366	[670] 75 364	[1400] 160 362	[2130] 240 356	[2860] 325 348	[3550] 400 338	[4260] 480 326	[4920] 555 308	[5590] 630 289	[6220] 705 262
[18] 68	[180] 20 410	[650] 75 409	[1360] 155 407	[2100] 235 401	[2830] 320 392	[3530] 400 382	[4250] 480 370	[4910] 555 350	[5600] 635 329	[6240] 705 302
[20] 76	[150] 15 460	[630] 70 458	[1340] 150 456	[2070] 235 448	[2800] 315 440	[3510] 395 429	[4240] 480 417	[4910] 555 396	[5610] 635 373	
[22] 83	[120] 15 509	[620] 70 506	[1330] 150 502	[2060] 235 494	[2790] 315 484	[3500] 395 473	[4220] 475 461	[4910] 555 438	[5600] 635 413	
[25] 95	[70] 10 582	[600] 70 578	[1320] 150 573	[2050] 230 563	[2780] 315 552	[3480] 395 540	[4210] 475 526	[4900] 555 501	[5590] 630 474	
[30] 114		[560] 65 693	[1280] 145 687	[1990] 225 675	[2700] 305 661	[3430] 390 647	[3970] 450 630	[4640] 525 600		

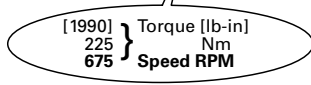

4000 Series

Performance Data

Motors run with high efficiency in all areas designated with a number for torque and speed. For best motor life select a motor to run with a torque and speed range shown in the light shaded area.

Performance data is typical at 120 SUS. Actual data may vary slightly from unit to unit in production.

	Continuous		Peak
	Intermittent		No Operation

245 cm³/r [15.0 in³/r]
Δ Pressure Bar [PSI]

		[250] 15	[500] 35	[750] 50	[1000] 70	[1250] 85	[1500] 105	[1750] 120	[2000] 140	[2250] 155	[2500] 170	[2750] 190	[3000] 205	[3250] 225	[3500] 240	[3750] 260		
Flow LPM [GPM]	[.5] 1.9	[460] 50 5	[980] 110 2															
	[1] 3.8	[480] 55 14	[990] 110 14	[1490] 170 14	[1990] 225 13	[2480] 280 13	[2970] 335 12	[3400] 385 12	[3830] 435 11	[4250] 480 11	[4680] 530 10	[5020] 565 4						
	[2] 7.5	[500] 55 30	[1000] 115 30	[1520] 170 29	[2040] 230 29	[2540] 285 28	[3050] 345 27	[3420] 385 26	[3930] 445 24	[4440] 500 23	[4900] 555 22	[5320] 600 20	[5740] 650 18	[6160] 695 16	[6640] 750 14	[7150] 810 11		
	[4] 15	[510] 60 61	[1030] 115 61	[1560] 170 60	[2080] 235 60	[2600] 295 59	[3130] 355 59	[3630] 415 58	[4130] 465 56	[4630] 525 53	[5120] 580 49	[5570] 630 47	[6030] 680 44	[6480] 730 42	[6870] 775 39	[7340] 830 36		
	[6] 23	[510] 60 91	[1040] 120 90	[1570] 175 90	[2100] 235 89	[2620] 295 88	[3160] 355 88	[3660] 415 86	[4200] 475 83	[4710] 530 80	[5220] 590 75	[5690] 645 72	[6150] 695 70	[6620] 750 67	[7050] 795 63	[7430] 840 59		
	[8] 30	[500] 55 121	[1020] 115 121	[1560] 175 120	[2100] 240 118	[2630] 295 117	[3150] 355 115	[3680] 415 113	[4210] 475 111	[4740] 535 106	[5250] 595 103	[5740] 645 103	[6200] 700 99	[6670] 755 96	[7090] 800 91	[7470] 845 87		
	[10] 38	[470] 55 152	[1000] 115 151	[1540] 175 150	[2100] 240 148	[2620] 295 148	[3150] 355 147	[3690] 415 145	[4230] 475 143	[4770] 540 141	[5290] 600 137	[5760] 655 133	[6240] 710 129	[6710] 765 125	[7140] 805 120			
	[12] 45	[450] 50 183	[980] 110 182	[1530] 175 180	[2080] 235 179	[2610] 295 178	[3140] 355 178	[3680] 415 176	[4220] 475 173	[4760] 540 170	[5280] 600 166	[5750] 650 161	[6230] 705 157	[6700] 755 152				
	[14] 53	[420] 45 213	[960] 110 212	[1520] 170 211	[2060] 235 210	[2600] 295 209	[3130] 355 208	[3670] 415 206	[4200] 475 203	[4740] 535 200	[5260] 595 195	[5740] 645 190	[6220] 700 185					
	[16] 61	[400] 45 244	[950] 105 243	[1500] 170 242	[2040] 230 241	[2580] 290 240	[3120] 355 239	[3660] 415 236	[4190] 475 232	[4730] 535 229	[5250] 595 225	[5730] 645 219	[6210] 700 213					
	[18] 68	[380] 45 275	[930] 105 274	[1480] 165 273	[2020] 230 272	[2560] 290 270	[3100] 350 269	[3650] 415 266	[4180] 475 262	[4710] 530 259	[5230] 585 254	[5720] 645 248	[6200] 700 241					
	[20] 76	[350] 40 305	[910] 105 305	[1460] 165 304	[2000] 225 302	[2550] 290 300	[3100] 350 296	[3640] 410 292	[4170] 470 288	[4700] 530 283	[5220] 585 276	[5710] 645 275						
	[22] 83	[310] 35 337	[870] 100 336	[1420] 160 335	[1970] 225 334	[2500] 280 332	[3050] 345 330	[3590] 405 326	[4140] 465 323	[4680] 525 319	[5200] 580 313	[5680] 640 306						
	[25] 95	[260] 30 383	[820] 95 382	[1380] 155 381	[1930] 220 380	[2460] 280 378	[2980] 335 376	[3540] 400 372	[4090] 460 369	[4640] 525 365	[5180] 585 357							
	[30] 114		[680] 75 457	[1250] 140 456	[1860] 210 455	[2390] 270 453	[2900] 330 450	[3430] 390 445	[3960] 445 442	[4460] 505 437	[4950] 560 427							
	[35] 132			[1110] 125 532	[1740] 195 531	[2270] 270 528	[2790] 315 525	[3340] 375 519	[3910] 440 515	[4400] 495 509								

280 cm³/r [17.1 in³/r]
Δ Pressure Bar [PSI]

		[250] 15	[500] 35	[750] 50	[1000] 70	[1250] 85	[1500] 105	[1750] 120	[2000] 140	[2250] 155	[2500] 170	[2750] 190	[3000] 205	[3250] 225	[3500] 240	[3750] 260		
Flow LPM [GPM]	[.5] 1.9	[533] 60 4	[1074] 121 2															
	[1] 3.8	[553] 62 12	[1136] 128 12	[1714] 194 12	[2287] 258 11	[2841] 321 11	[3394] 384 10	[3868] 437 10	[4389] 496 10	[4895] 553 8	[6080] 685 6	[5870] 663 6	[368] 720 6	[6811] 770 5	[7239] 818 5	[7654] 865 4		
	[2] 7.5	[568] 64 26	[1146] 130 26	[1740] 197 25	[2328] 263 25	[2902] 328 24	[3461] 391 24	[3955] 447 23	[4524] 511 22	[5092] 566 21	[6360] 694 20	[6146] 673 19	[6666] 753 17	[7191] 813 17	[7749] 876 15	[8323] 940 13		
	[4] 15	[579] 65 53	[1167] 132 53	[1771] 200 52	[2374] 268 52	[2962] 335 51	[3557] 402 51	[4139] 468 50	[4712] 532 49	[5285] 597 47	[6080] 685 45	[5870] 663 44	[6395] 722 44	[6946] 785 42	[7502] 848 41	[8020] 906 40	[8471] 957 38	
	[6] 23	[583] 66 79	[1177] 133 79	[1781] 201 78	[2395] 271 78	[2987] 338 77	[3601] 407 77	[4193] 474 76	[4793] 542 74	[5399] 607 72	[6420] 737 69	[6211] 703 67	[6721] 793 66	[7382] 859 66	[8097] 915 65			
	[8] 30	[573] 65 106	[1167] 132 106	[1780] 201 105	[2404] 272 105	[3007] 340 104	[3610] 408 104	[4218] 477 102	[4812] 544 101	[5411] 611 99	[6111] 677 96	[6566] 741 94	[7022] 793 92	[7518] 849 92				
	[10] 38	[547] 62 134	[1146] 130 133	[1765] 199 133	[2395] 271 131	[2997] 339 131	[3629] 410 130	[4238] 479 129	[4837] 547 127	[5442] 615 126	[6350] 746 122	[6035] 702 119	[6601] 746 115	[7022] 793 115	[7518] 849 111			
	[12] 45	[527] 60 161	[1126] 127 160	[1745] 197 186	[2369] 268 158	[2991] 338 157	[3609] 408 157	[4228] 478 156	[4832] 546 154	[5441] 615 152	[6420] 744 148	[6034] 703 144	[6586] 744 141	[6940] 784 141				
	[14] 53	[497] 56 187	[1106] 125 187	[1730] 195 186	[2344] 265 186	[2972] 336 185	[3585] 405 184	[4213] 476 182	[4816] 544 180	[5430] 614 178	[6350] 746 174	[6028] 681 170	[6511] 736 166	[6940] 784 166				
	[16] 61	[472] 53 214	[1096] 124 214	[1715] 194 213	[2324] 263 212	[2947] 333 211	[3565] 403 210	[4203] 475 208	[4811] 544 206	[5420] 612 203	[6420] 744 199	[6034] 689 195	[6586] 727 195	[6940] 784 195				
	[18] 68	[437] 39 241	[1075] 121 241	[1690] 191 240	[2299] 260 239	[2917] 330 237	[3541] 400 236	[4188] 473 234	[4801] 542 231	[5400] 610 229	[6420] 744 224	[6034] 689 224	[6586] 719 224	[6940] 784 224				
	[20] 76	[402] 45 268	[1055] 119 268	[1669] 189 268	[2274] 257 267	[2898] 327 266	[3521] 398 264	[4178] 472 261	[4791] 541 258	[5394] 609 255	[6420] 744 249	[6034] 689 249	[6586] 719 249	[6940] 784 249				
	[22] 83	[366] 41 296	[1005] 114 295	[1629] 184 295	[2257] 255 294	[2856] 323 292	[3480] 393 290	[4136] 467 288	[4756] 537 285	[5205] 588 279								
	[25] 95	[301] 34 336	[940] 106 336	[1588] 179 335	[2231] 252 334	[2825] 319 333	[3419] 386 331	[4086] 462 328	[4710] 532 325	[5205] 588 314								
	[30] 114		[845] 96 402	[1480] 167 401	[2151] 243 400	[2759] 312 398	[3328] 376 396	[3984] 450 392	[4573] 517 389	[5021] 567 377								
	[35] 132			[1348] 152 468	[2057] 232 466	[2623] 296 464	[3183] 360 463	[3883] 439 457	[4354] 492 449									

[3340] } Torque [lb-in]
[375] } Nm
[519] } Speed RPM

4000 Series

310 cm³/r [19.0 in³/r]
Δ Pressure Bar [PSI]

Performance Data

Motors run with high efficiency in all areas designated with a number for torque and speed. For best motor life select a motor to run with a torque and speed range shown in the light shaded area.

Performance data is typical at 120 SUS. Actual data may vary slightly from unit to unit in production.

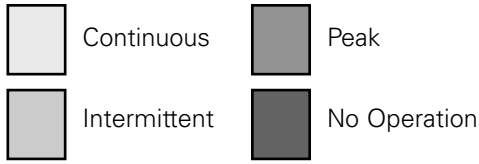

		[250] 15	[500] 35	[750] 50	[1000] 70	[1250] 85	[1500] 105	[1750] 120	[2000] 140	[2250] 155	[2500] 170	[2750] 190	[3000] 205	[3250] 225	[3500] 240	[3750] 260
Flow LPM [GPM]	[.5]	[600] 70	[1150] 130													
	1.9	4	2													
	[1]	[620] 70	[1270] 145	[1920] 215	[2560] 290	[3170] 360	[3780] 425	[4290] 485	[4900] 555	[5490] 620	[6080] 685	[6670] 755	[7270] 820	[7880] 890	[8490] 960	[9080] 1025
	3.8	11	11	11	10	10	10	9	9	9	8	8	7	7	6	5
	[2]	[630] 73	[1280] 145	[1940] 220	[2590] 295	[3230] 365	[3830] 435	[4450] 505	[5070] 575	[5680] 640	[6300] 710	[6910] 780	[7530] 850	[8160] 920	[8790] 995	[9420] 1065
	7.5	20	23	22	22	21	21	21	20	20	19	18	17	17	16	15
	[4]	[640] 70	[1290] 145	[1960] 220	[2640] 300	[3290] 370	[3940] 445	[4600] 520	[5240] 590	[5880] 665	[6510] 735	[7150] 810	[7790] 880	[8450] 955	[9100] 1030	
	15	47	47	46	46	45	45	44	44	43	42	42	41	41	40	
	[6]	[650] 75	[1300] 145	[1970] 225	[2660] 300	[3320] 375	[4000] 450	[4680] 530	[5330] 600	[5980] 675	[6630] 750	[7280] 825	[7940] 895			
	23	71	71	70	70	69	69	68	67	66	64	64	63			
	[8]	[640] 70	[1300] 145	[1980] 225	[2670] 300	[3350] 380	[4030] 455	[4710] 530	[5360] 605	[6020] 680	[6670] 755	[7320] 830				
	30	96	96	95	95	94	94	93	92	91	89	88				
	[10]	[620] 70	[1280] 145	[1970] 225	[2660] 300	[3340] 375	[4070] 460	[4740] 535	[5390] 610	[6050] 685	[6710] 760	[7370] 835				
	38	121	120	120	119	119	118	117	116	115	112	109				
	[12]	[600] 70	[1260] 140	[1940] 220	[2630] 295	[3340] 375	[4040] 455	[4730] 535	[5390] 610	[6060] 685	[6720] 760					
	45	145	144	144	143	142	142	141	140	139	135					
	[14]	[570] 65	[1240] 140	[1920] 215	[2600] 295	[3310] 375	[4000] 450	[4710] 530	[5380] 610	[6060] 685	[6730] 760					
	53	169	169	168	168	167	167	165	164	163	159					
	[16]	[540] 60	[1230] 140	[1900] 215	[2580] 290	[3280] 370	[3970] 450	[4700] 530	[5380] 610	[6050] 685						
	61	193	193	192	192	190	189	188	187	185						
[18]	[490] 55	[1210] 135	[1880] 210	[2550] 290	[3240] 365	[3930] 445	[4680] 530	[5370] 605	[6040] 680							
68	217	217	216	216	214	213	211	209	207							
[20]	[450] 50	[1190] 135	[1860] 210	[2520] 285	[3210] 365	[3900] 440	[4670] 530	[5360] 605	[6030] 680							
76	242	242	242	241	240	238	236	234	232							
[22]	[420] 45	[1130] 130	[1820] 205	[2520] 285	[3180] 360	[3870] 440	[4640] 525	[5320] 600								
83	267	266	266	265	264	262	260	258								
[25]	[340] 40	[1050] 120	[1780] 200	[2510] 285	[3160] 355	[3820] 430	[4590] 520	[5280] 595								
95	303	303	302	301	300	299	296	293								
[30]		[1010] 115	[1700] 190	[2420] 275	[3100] 350	[3720] 420	[4500] 510	[5140] 580								
114		363	362	360	359	358	354	351								
[35]			[1580] 180	[2360] 265	[2950] 335	[3540] 400	[4390] 495									
132			422	420	419	418	413									

395 cm³/r [24.0 in³/r]
Δ Pressure Bar [PSI]

		[250] 15	[500] 35	[750] 50	[1000] 70	[1250] 85	[1500] 105	[1750] 120	[2000] 140	[2250] 155	[2500] 170	[2750] 190	[3000] 205	[3250] 225	[3500] 240
Flow LPM [GPM]	[.5]	[700] 80	[1340] 150												
	1.9	4	2												
	[1]	[750] 85	[1430] 160	[2110] 240	[2770] 315	[3460] 390	[4170] 470	[4890] 550	[5610] 635	[6310] 715	[7010] 790	[7700] 870			
	3.8	9	9	8	8	8	7	7	7	5	4	2			
	[2]	[800] 90	[1500] 170	[2290] 260	[3030] 340	[3850] 435	[4620] 520	[5310] 600	[6000] 680	[6750] 765	[7490] 845	[8240] 930	[8990] 1015	[9730] 1100	[10470] 1185
	7.5	18	18	17	16	16	15	15	14	13	13	12	11	10	8
	[4]	[860] 95	[1630] 185	[2470] 280	[3310] 375	[4120] 465	[4900] 555	[5640] 635	[6390] 720	[7190] 810	[7890] 890	[8780] 990			
	15	38	38	37	36	36	35	35	34	34	33	32			
	[6]	[860] 95	[1690] 190	[2540] 285	[3410] 385	[4180] 470	[4980] 565	[5780] 655	[6580] 745	[7400] 835	[8220] 930				
	23	57	57	56	55	54	53	52	50	49	47				
	[8]	[840] 95	[1680] 190	[2550] 290	[3400] 385	[4260] 480	[5090] 575	[5870] 665	[6650] 750	[7480] 845					
	30	76	76	75	74	73	72	70	68	66					
	[10]	[800] 90	[1680] 190	[2550] 290	[3400] 385	[4260] 480	[5100] 575	[5920] 670	[6730] 760	[7560] 855					
	38	95	95	94	93	92	91	89	86	84					
	[12]	[760] 85	[1660] 190	[2520] 285	[3380] 380	[4270] 480	[5110] 575	[5900] 665	[6690] 755						
	45	114	114	113	112	111	110	108	105						
	[14]	[740] 85	[1640] 185	[2490] 280	[3370] 380	[4260] 480	[5100] 575	[5880] 665	[6650] 750						
	53	133	133	132	131	130	129	127	124						
	[16]	[710] 80	[1620] 185	[2460] 280	[3350] 380	[4240] 480	[5080] 575	[5840] 660							
	61	153	153	152	151	149	147	145							
[18]	[680] 75	[1600] 180	[2430] 275	[3340] 375	[4220] 475	[5060] 570	[5810] 655								
68	172	172	171	170	168	166	164								
[20]	[610] 70	[1580] 180	[2400] 270	[3320] 375	[4210] 475	[5040] 570	[5780] 655								
76	192	191	190	189	187	185	183								
[22]	[570] 65	[1490] 170	[2340] 265	[3220] 365	[4160] 470	[5010] 565	[5740] 650								
83	211	210	209	208	206	204	201								
[25]	[490] 55	[1350] 155	[2250] 255	[3080] 350	[4070] 460	[4960] 560	[5700] 645								
95	239	238	237	236	235	233									
[30]		[1080] 120	[1650] 185	[2270] 255	[3020] 340	[3850] 435									
114		285	284	282	281	279									
[35]			[1520] 170	[2120] 240	[2870] 325	[3760] 425									
132			331	330	328	325									
[40]				[2050] 230	[2790] 315	[3620] 410									
151				376	374	371									

[4390] Torque [lb-in]
495 Nm
413 Speed RPM

4000 Series

Performance Data

Motors run with high efficiency in all areas designated with a number for torque and speed. For best motor life select a motor to run with a torque and speed range shown in the light shaded area.

Performance data is typical at 120 SUS. Actual data may vary slightly from unit to unit in production.

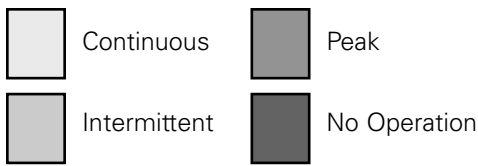

625 cm³/r [38.0 in³/r]
Δ Pressure Bar [PSI]

	[250] 15	[500] 35	[750] 50	[1000] 70	[1250] 85	[1500] 105	[1600] 100	[1700] 115	[1800] 125	[2000] 140
[.5] 1,9	[1000] 115 2									
[1] 3,8	[1080] 120 5	[2340] 265 5	[3600] 405 5	[4850] 550 4	[6100] 690 4	[7350] 830 3	[7820] 885 3	[8290] 935 2	[8760] 990 2	
[2] 7,5	[1085] 125 14	[2380] 270 14	[3675] 415 14	[5010] 565 13	[6350] 715 12	[7625] 860 11	[8115] 915 10	[8605] 970 9	[9095] 1030 8	[10075] 1140 7
[4] 15	[1090] 125 23	[2420] 275 23	[3750] 425 23	[5175] 585 22	[6600] 745 21	[7900] 895 19	[8410] 950 18	[9000] 1015 17	[9590] 1085 16	[10450] 1180 14
[6] 23	[1095] 125 35	[2460] 280 35	[3825] 430 35	[5220] 590 34	[6620] 750 33	[7950] 900 31	[8430] 950 30	[8910] 1005 29	[9490] 1070 28	
[8] 30	[1100] 125 48	[2500] 280 48	[3900] 440 47	[5270] 595 46	[6640] 750 45	[7990] 905 43	[8460] 955 43	[8925] 1010 42		
[10] 38	[1130] 130 60	[2550] 290 60	[3975] 450 59	[5320] 600 58	[6670] 755 57	[8045] 910 54	[8595] 970 53	[9150] 1035 52		
[12] 45	[1160] 130 72	[2600] 295 72	[4050] 460 71	[5375] 605 70	[6700] 755 69	[8100] 915 65	[8660] 980 64			
[14] 53	[1105] 125 84	[2535] 285 84	[3965] 450 83	[5325] 600 82	[6685] 755 81	[8065] 910 77	[8620] 975 76			
[16] 61	[1050] 120 96	[2465] 280 95	[3880] 440 95	[5275] 595 94	[6670] 755 93	[8035] 910 89	[8580] 970 88			
[18] 68	[990] 110 108	[2405] 270 107	[3825] 430 107	[5240] 590 105	[6655] 750 104	[7345] 830 100				
[20] 76	[930] 105 121	[2350] 265 120	[3770] 425 120	[5205] 590 118	[6640] 750 116					
[25] 95	[750] 85 151	[2175] 245 150	[3600] 405 149	[5000] 565 147	[6400] 725 146					
[30] 114	[550] 60 181	[1975] 225 180	[3400] 385 179	[4800] 530 177	[6200] 700 176					
[35] 132			[3125] 355 210	[4545] 515 208						
[40] 151			[2850] 320 241	[4295] 485 239						

495 cm³/r [30.0 in³/r]
Δ Pressure Bar [PSI]

	[250] 15	[500] 35	[750] 50	[1000] 70	[1250] 85	[1500] 105	[1750] 120	[2000] 140	[2250] 155	[2500] 170
[.5] 1,9	[800] 90 3	[1750] 200 1								
[1] 3,8	[880] 100 7	[1875] 210 6	[2875] 325 6	[3825] 430 5	[4775] 540 4	[5720] 645 3	[6670] 755 2	[7600] 860 1		
[2] 7,5	[905] 100 18	[1940] 220 17	[2975] 335 17	[3990] 450 16	[5010] 565 15	[6010] 680 12	[7010] 790 11	[8000] 905 10	[8980] 1015 8	
[4] 15	[935] 105 30	[2005] 225 29	[3075] 345 28	[4160] 470 27	[5245] 595 26	[6300] 710 23	[7355] 830 21	[8375] 945 19	[9400] 1060 17	[10350] 1170 14
[6] 23	[920] 105 45	[2010] 225 44	[3100] 350 43	[4185] 475 42	[5265] 595 40	[6345] 715 37	[7420] 840 35	[8445] 955 32	[9465] 1070 30	
[8] 30	[905] 100 61	[2015] 230 60	[3125] 355 59	[4205] 475 57	[5290] 600 55	[6385] 720 52	[7485] 845 49	[8510] 960 46		
[10] 38	[880] 100 76	[1995] 225 75	[3095] 350 74	[4205] 475 72	[5295] 600 70	[6390] 720 66	[7480] 845 63	[8525] 960 59		
[12] 45	[860] 95 91	[1975] 225 90	[3095] 350 89	[4200] 475 87	[5305] 600 85	[6390] 720 81	[7475] 845 77			
[14] 53	[830] 95 106	[1945] 220 105	[3055] 345 104	[4165] 470 102	[5275] 595 100	[6360] 720 96	[7445] 840 92			
[16] 61	[805] 90 122	[1910] 215 120	[3020] 340 119	[4130] 465 117	[5245] 595 115	[6330] 715 111	[7420] 840 107			
[18] 68	[740] 85 137	[1860] 210 136	[2980] 335 134	[4105] 465 132	[5235] 590 130	[6305] 715 125	[7380] 835 121			
[20] 76	[680] 75 153	[1810] 205 152	[2940] 330 150	[4085] 460 147	[5225] 590 145	[6285] 710 140				
[25] 95	[570] 65 191	[1665] 190 189	[2800] 315 187	[4005] 455 184	[5210] 590 182	[6135] 695 177				
[30] 114		[1520] 170 228	[2645] 300 226	[3765] 425 223	[4885] 550 220	[5985] 675 215				
[35] 132			[2400] 270 265	[3510] 395 263						
[40] 151			[2155] 245 305	[3260] 370 303						

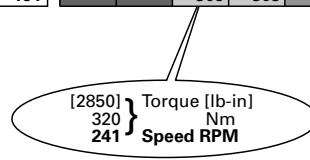

4000 Series

Dimensions

Standard Mount

Ports

- 1 1/16 -12 UN-2B SAE O-ring Staggered Ports (2)
- 7/16 -20 UNF-2B SAE O-ring Case Drain Port (1) or
- 4 Bolt 3/4 inch Split Flange Ports (2)
- 7/16 -20 UNF-2B SAE O-ring Case Drain Port (1) or
- G 3/4 (BSP) Staggered Ports (2)
- G 1/4 (BSP) Case Drain Port (1)

Standard Rotation Viewed from Shaft End

- Port A Pressurized — CW
- Port B Pressurized — CCW

Standard Mount

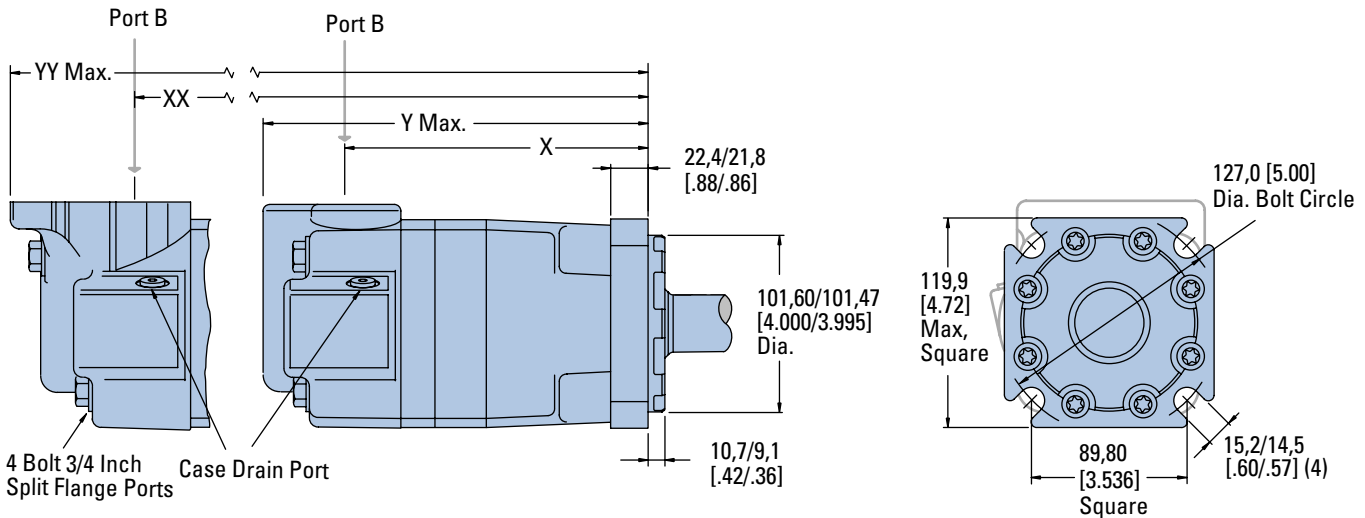

SAE C Flange

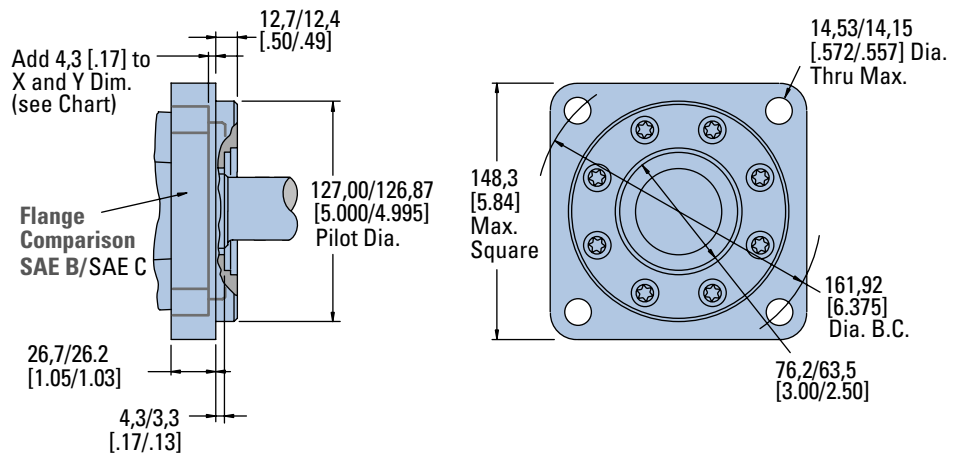

STANDARD MOUNT MOTOR DIMENSIONS

Displacement cm ³ /r [in ³ /r]	X mm [inch]	Y mm [inch]	XX mm [inch]	YY mm [inch]
110 [6.7]	158,3 [6.23]	214,4 [8.44]	167,3 [6.59]	246,3 [9.70]
130 [7.9]	162,3 [6.39]	218,4 [8.60]	171,3 [6.75]	250,4 [9.86]
160 [9.9]	168,7 [6.64]	224,7 [8.85]	177,7 [7.00]	256,7 [10.11]
205 [12.5]	177,2 [6.98]	233,2 [9.18]	186,2 [7.33]	265,2 [10.44]
245 [15.0]	168,7 [6.64]	224,7 [8.85]	177,7 [7.00]	256,7 [10.11]
310 [19.0]	177,2 [6.98]	233,2 [9.18]	186,2 [7.33]	265,2 [10.44]
395 [24.0]	187,9 [7.40]	243,9 [9.60]	196,9 [7.75]	275,9 [10.86]
495 [30.0]	200,7 [7.90]	256,8 [10.11]	209,7 [8.26]	288,8 [11.37]
625 [38.0]	217,8 [8.58]	273,9 [10.78]	226,7 [8.93]	305,9 [12.04]

4000 Series

Dimensions

Wheel Mount

Wheel Mount

Ports

- 1 1/16 -12 UN-2B SAE O-ring Staggered Ports (2)
- 7/16 -20 UNF-2B SAE O-ring Case Drain Port (1) or
- 4 Bolt 3/4 inch Split Flange Ports (2)
- 7/16 -20 UNF-2B SAE O-ring Case Drain Port (1) or
- G 3/4 (BSP) Staggered Ports (2)
- G 1/4 (BSP) Case Drain Port (1)

Standard Rotation Viewed from Shaft End

- Port A Pressurized — CW
- Port B Pressurized — CCW

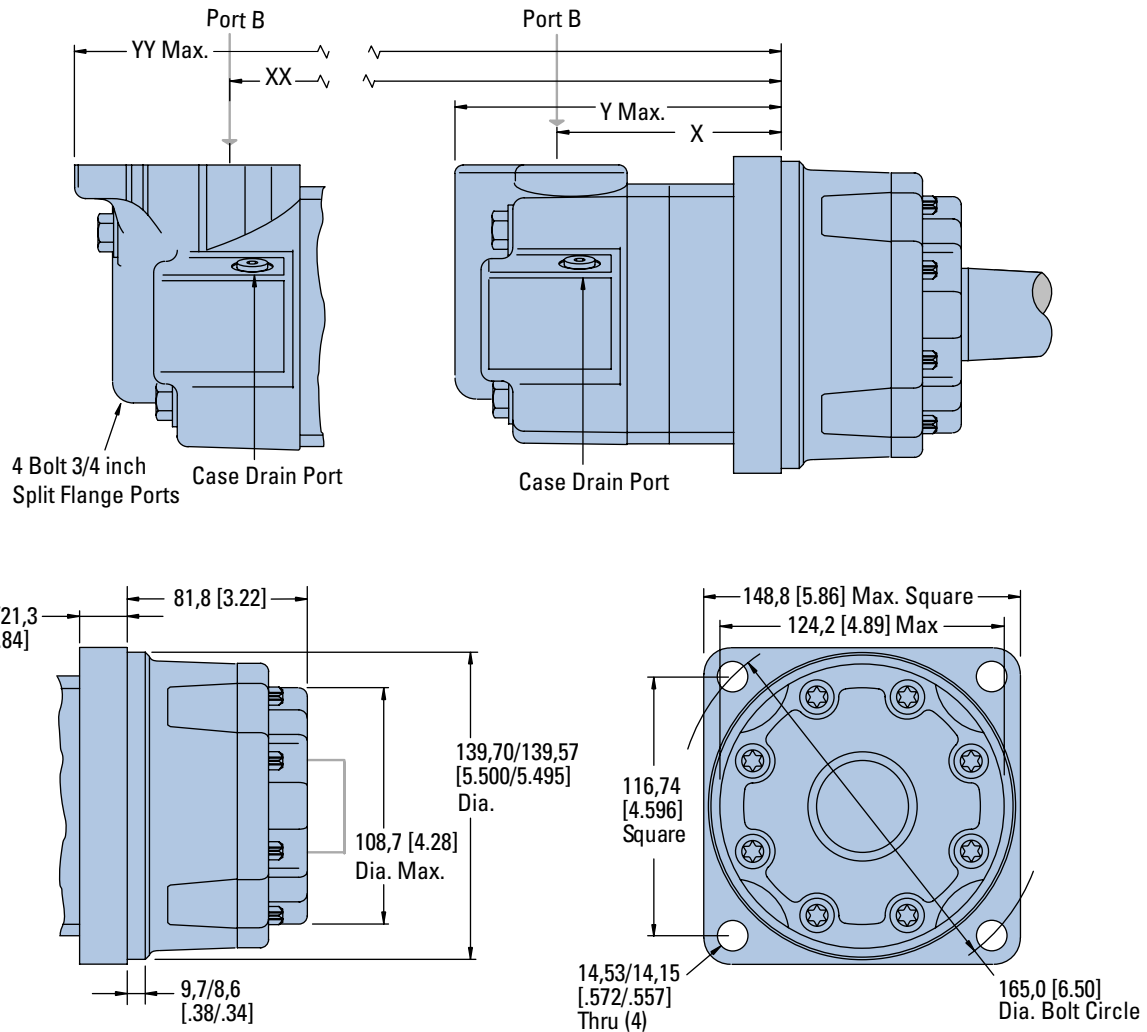

WHEEL MOUNT MOTOR DIMENSIONS

Displacement cm ³ /r [in ³ /r]	X mm [inch]	Y mm [inch]	XX mm [inch]	YY mm [inch]
110 [6.7]	87,5 [3.45]	143,3 [5.64]	96,4 [3.80]	175,3 [6.90]
130 [7.9]	91,6 [3.61]	147,3 [5.80]	100,5 [3.96]	179,3 [7.06]
160 [9.9]	97,8 [3.85]	153,7 [6.05]	106,8 [4.21]	185,7 [7.31]
205 [12.5]	106,4 [4.19]	162,3 [6.39]	115,4 [4.55]	194,3 [7.65]
245 [15.0]	97,8 [3.85]	153,7 [6.05]	106,8 [4.21]	185,7 [7.31]
310 [19.0]	106,4 [4.19]	162,3 [6.39]	115,4 [4.55]	194,3 [7.65]
395 [24.0]	117,1 [4.61]	173,0 [6.81]	126,1 [4.97]	205,0 [8.07]
495 [30.0]	129,9 [5.12]	185,7 [7.31]	138,8 [5.47]	217,7 [8.57]
625 [38.0]	146,9 [5.79]	202,9 [7.99]	156,0 [6.14]	235,0 [9.25]

4000 Series

Dimensions

Bearingless

Bearingless

Ports

- 1 1/16 -12 UN-2B SAE O-ring Staggered Ports (2)
- 7/16 -20 UNF-2B SAE O-ring Case Drain Port (1) or
- 4 Bolt 3/4 inch Split Flange Ports (2)
- 7/16 -20 UNF-2B SAE O-ring Case Drain Port (1) or
- G 3/4 (BSP) Staggered Ports (2)
- G 1/4 (BSP) Case Drain Port (1)

Standard Rotation Viewed from Shaft End

- Port A Pressurized — CW
- Port B Pressurized — CCW

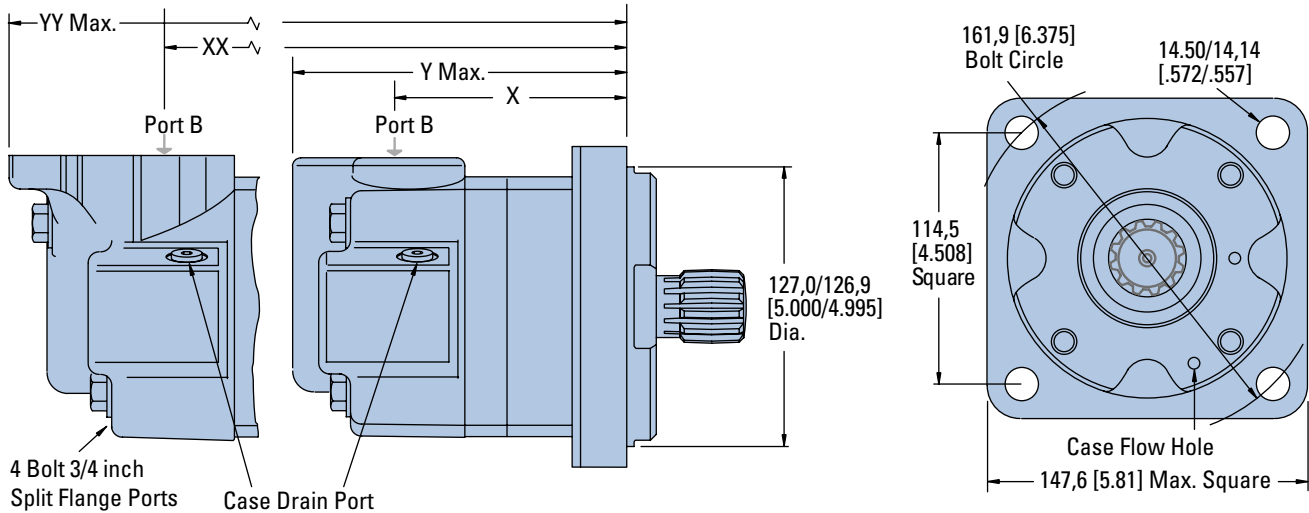

For 4000 Series Bearingless Motor application information contact your Eaton representative (mating coupling blanks available from Eaton Hydraulics).

Note:

After machining blank, part must be hardened per Eaton specification.

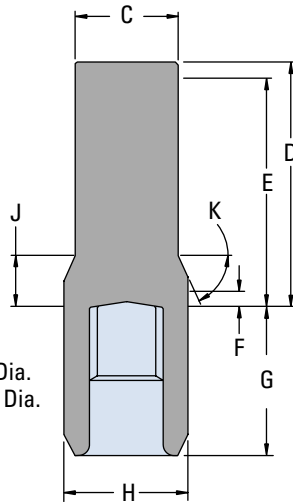

- C 47,2 [1.86] Dia.
- D 112,5 [4.43] Max.
- E 107,4 [4.23] Full Form Dia.
- F 7,4 [.29] Min. Full Form Dia.
- G 68,8 [2.71] Max.
- H 56,9 [2.24] Dia.
- J 18,29 [.720]
- K 38°

Mating Coupling Blank
Eaton Part No. 12745-003

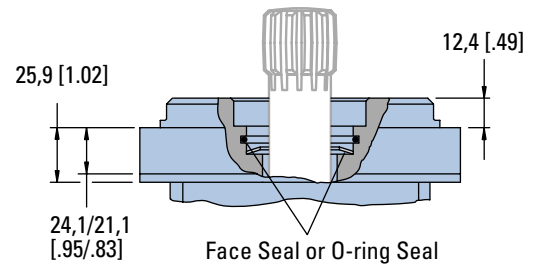
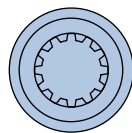

BEARINGLESS MOTOR DIMENSIONS

Displacement cm ³ /r [in ³ /r]	X mm [inch]	Y mm [inch]	XX mm [inch]	YY mm [inch]
110 [6.7]	91,0 [3.58]	146,8 [5.78]	100,1 [3.94]	178,8 [7.04]
130 [7.9]	95,0 [3.74]	150,8 [5.94]	104,1 [4.10]	182,9 [7.20]
160 [9.9]	101,4 [4.00]	157,1 [6.19]	110,5 [4.35]	189,2 [7.45]
205 [12.5]	109,9 [4.33]	165,7 [6.52]	118,9 [4.68]	197,6 [7.78]
245 [15.0]	101,4 [4.00]	157,1 [6.19]	110,5 [4.35]	189,2 [7.45]
310 [19.0]	109,9 [4.33]	165,7 [6.52]	118,9 [4.68]	197,6 [7.78]
395 [24.0]	120,6 [4.75]	176,3 [6.94]	129,5 [5.10]	208,3 [8.20]
495 [30.0]	133,5 [5.26]	189,2 [7.45]	142,5 [5.61]	221,2 [8.71]
625 [38.0]	150,5 [5.93]	206,3 [8.12]	159,5 [6.28]	238,3 [9.38]

4000 Series

Installation Information

Bearingless

- 1 Internal spline in mating part to be as follows: Material to be ASTM A304, 8620H. Carbonize to a hardness of 60-64 HRc with case depth (to 50HRc) of 0,076 - 1,27 [.030 - .050] (dimensions apply after heat treat).
- 2 Mating part to have critical dimensions as shown. Oil holes must be provided and open for proper oil circulation.
- 3 Seal to be furnished with motor for proper oil circulation thru splines.
- 4 Some means of maintaining clearance between shaft and mounting flange must be provided.
- 5 Counterbore designed to adapt to a standard sleeve bearing 50,010 - 50,040 [1.9689 - 1.9700] ID by 60,050 - 60,080 [2.3642 - 2.3653] (Oilite bronze sleeve bearing).
- 6 Similar to SAE "C" Four Bolt Flange.
- 7 52,8 [2.08] Max. dimension to be maintained when assembling shipping and installing unit to insure valve drive engagement with valve (this is required on displacement code number 24 only).

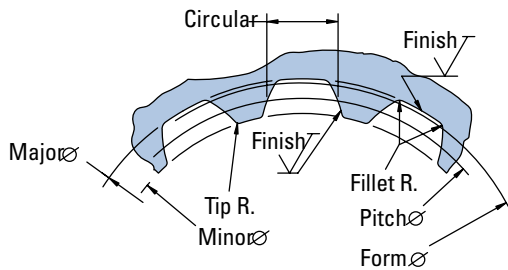
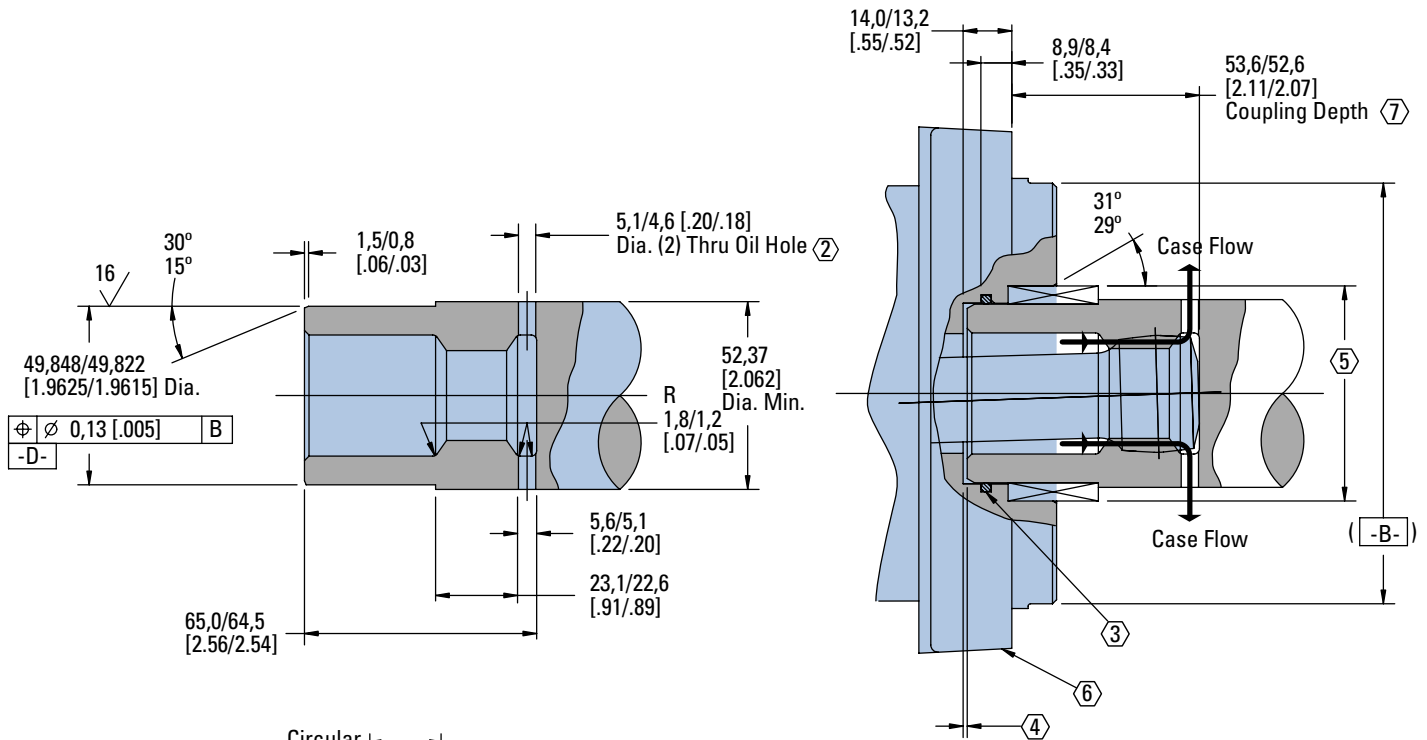

Spline Pitch.....	10/20
Pressure Angle.....	30°
Number of teeth.....	12
Class of Fit.....	Ref. 5
Type of Fit.....	Side
Pitch Diameter.....	Ref. 30,480000 [1.2000000] $\begin{matrix} \nearrow & 0,20 & [.008] \\ \searrow & & \end{matrix}$ D
Base Diameter.....	Ref. 26,396455 [1.0392305]
Major Diameter.....	33,43 [1.316] Max. 33,23 [1.308] Min.
Min. Minor Diameter.....	28,40 - 28,58 [1.118 - 1.125]
Form Diameter, Min.....	32,59 [1.283]
Fillet Radius.....	0,63 - 0,76 [.025 - .030]
Tip Radius.....	0,26 - 0,51 [.010 - .020]
Finish.....	1,6 (63)
Involute Profile Variation.....	+0,000 -0,025 [+ .0000 - .0010]
Total Index Variation.....	0,038 [.0015]
Lead Variation.....	0,013 [.0005]
Circular Space Width:	
Maximum Actual.....	5,045 [1.986]
Minimum Effective.....	4,995 [1.951]
Maximum Effective.....	Ref. 5,009 [1.972]
Minimum Actual.....	Ref. 4,986 [1.963]
Dimension Between Two Pins.....	Ref. 22,783 - 22,929 [.8970 - .9027]
Pin Diameter.....	5,334 [.2100] Pins to Have 3,73 [.147]
	Wide Flat for Root Clearance

4000 Series

Dimensions

Shafts

1 1/4 Inch Straight

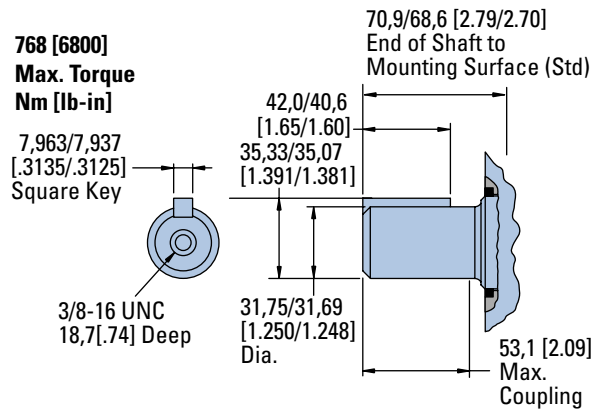

1 1/4 -14 Tooth Splined

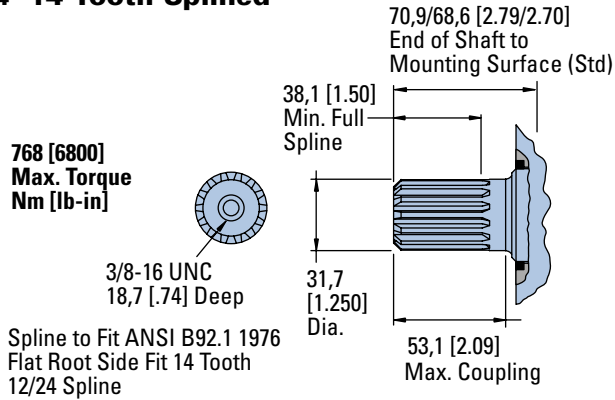

1 5/8 Tapered

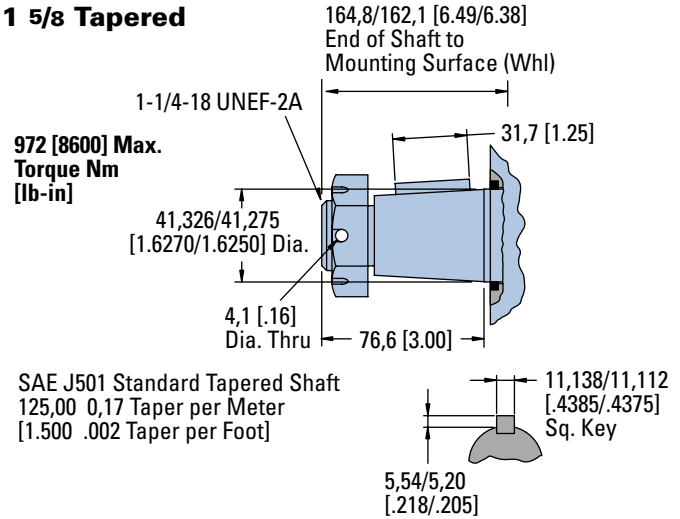

40 mm Straight

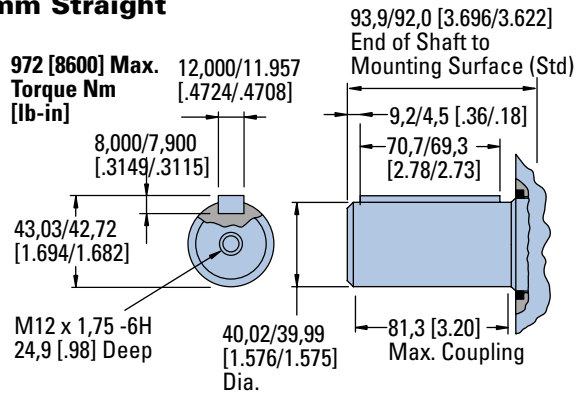

Tapered Shaft Hub Data

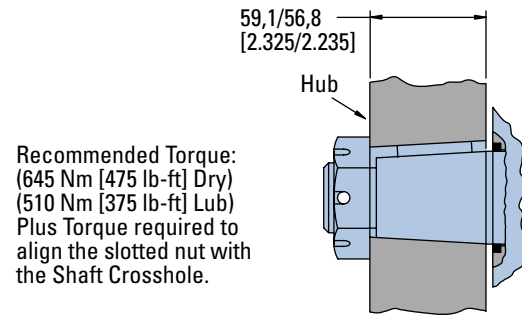

1 1/2 Inch 17-Tooth Splined

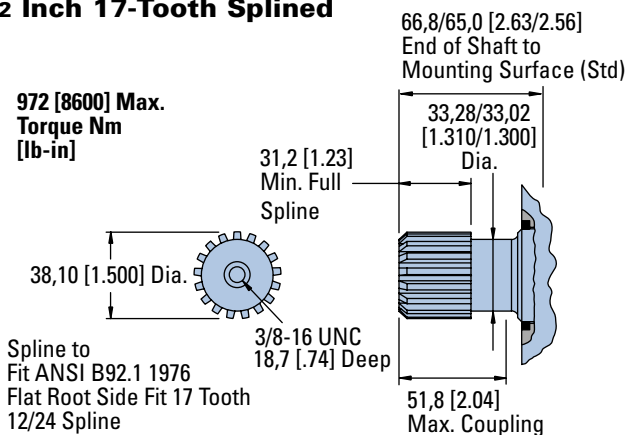

Slotted Hexagon Nut

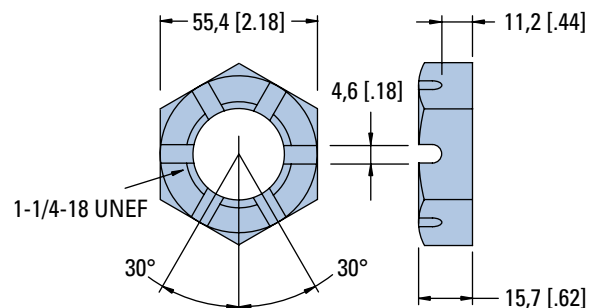

4000 Series

Shaft Side Load Capacity

These curves indicate the radial load capacity on the motor shaft(s) at various locations with an allowable external thrust load of 454 kg [1000 lb].

Note:

Case pressure will increase the allowable Inward thrust load and decrease the allowable outward thrust load. Case pressure will push outward on the shaft at 94 kg/7 Bar [208 lb/100 PSI].

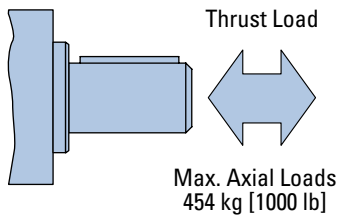

Each curve is based on B 10 bearing life (2000 hours of 12,000,000 shaft revolutions at 100 RPM) at rated output torque.

To determine radial load at speeds other than 100 RPM, multiply the load values given on the bearing curve by the factors in the chart below.

RPM	Multiplication Factor
50	1.23
100	1.00
200	0.81
300	0.72
400	0.66
500	0.62
600	0.58
700	0.56
800	0.54

For 3,000,000 shaft revolutions or 500 hours—Increase these shaft loads 52%.

Standard Motor
Straight and Splined Shafts

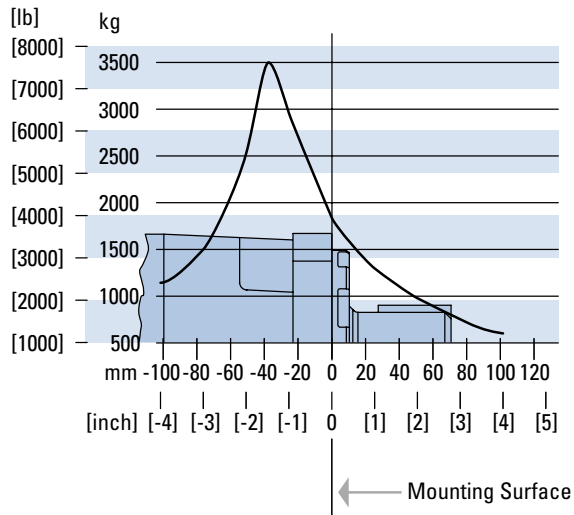

Wheel Motor Tapered Shaft

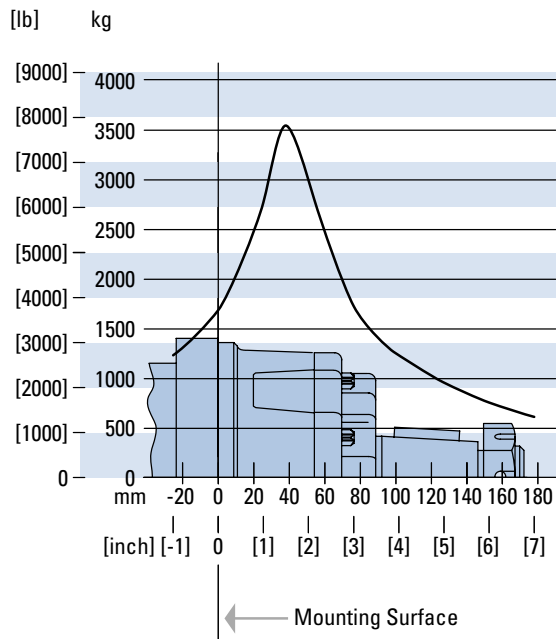

4000 Series

Case Pressure and Case Port

Char-Lynn 4000 Series motors are durable and have long life as long as the recommended case pressure is not exceeded. Allowable case pressure is highest at low shaft speeds. Consequently, motor life will be shortened if case pressure exceeds these ratings (acceptability may vary with application). Determine if an external case drain is required from the case pressure seal limitation chart.

Case Porting Advantage

Contamination Control — flushing the motor case.

Cooler Motor — exiting oil draws motor heat away.

Extend Motor Seal Life — maintain low case pressure with a preset restriction in the case drain line.

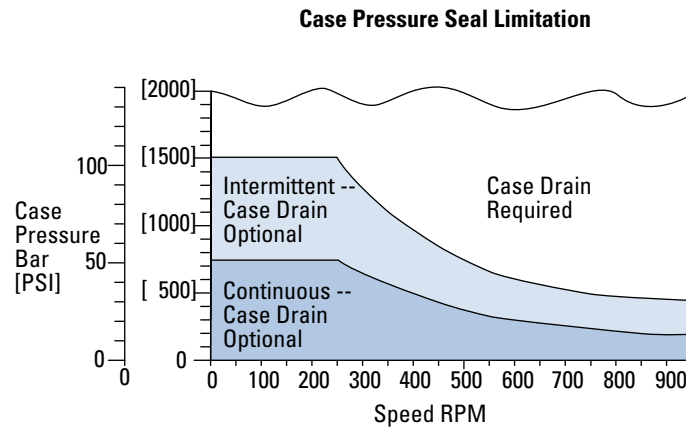

4000 Series

Dimensions

Ports

1-1/16-12 O-ring Ports (2) or G 3/4 (BSP) Ports (2)

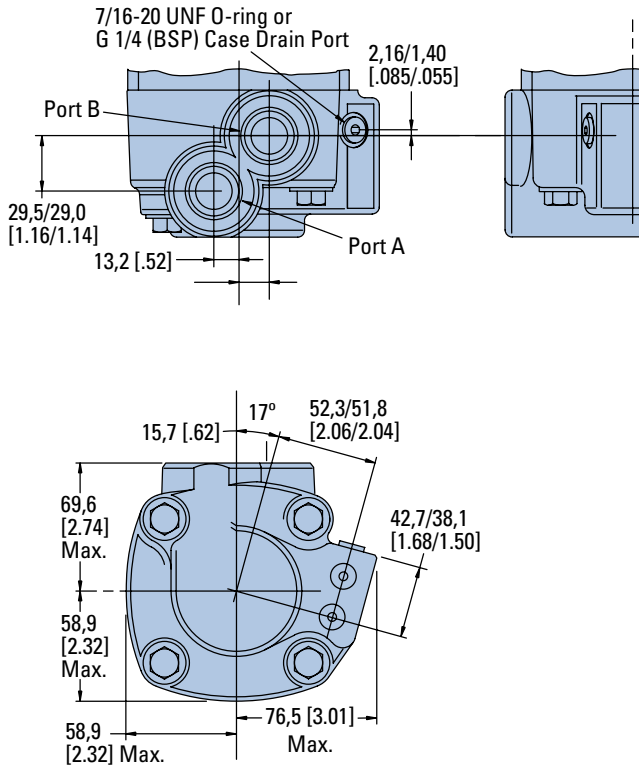

4 Bolt 3/4 Inch Split Flange Ports to Fit SAE J518 c (2)

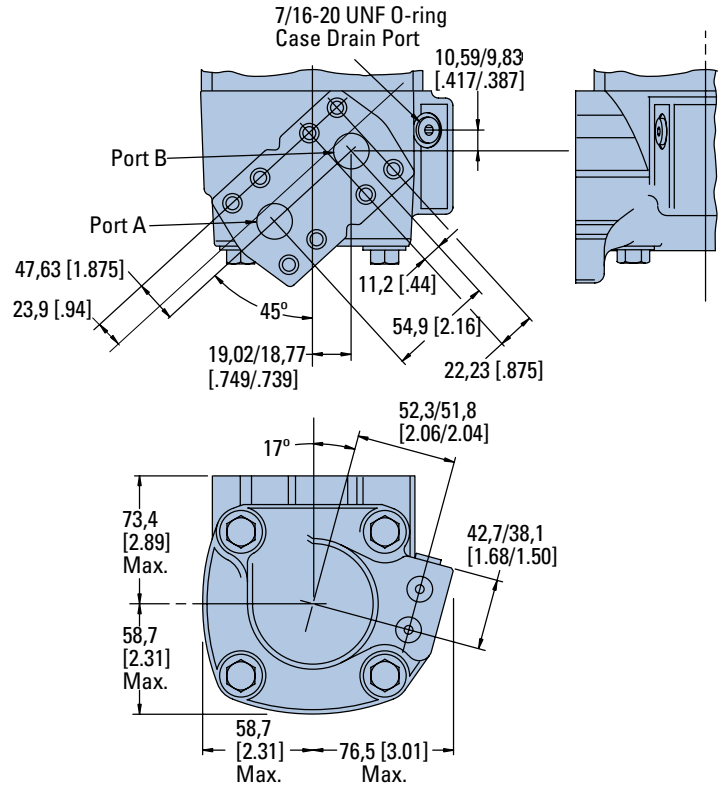

7/8-14 O-ring Ports (2) or M22 x 1,5-6H Ports (2)

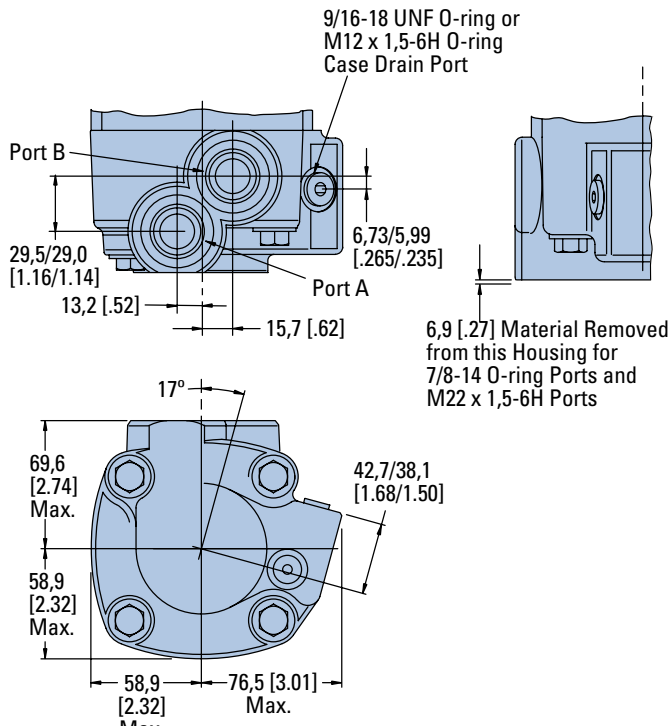

4000 Series

Product Numbers

Note:

For 4000 Series Motors with a configuration **Not Shown** in the charts below: Use model code number system on the next page to specify product in detail.

Use digit prefix —109-, 110-, or 111- plus four digit number from charts for complete product number— Example 111-1057.

Orders will not be accepted without three digit prefix.

MOUNTING	SHAFT	PORT SIZEDISPL. cm ³ /r [in ³ /r] / PRODUCT NUMBER										
		110 [6.7]	130 [7.9]	160 [9.9]	205 [12.5]	245 [15.0]	280* [17.1]	310 [19.0]	395 [24.0]	495 [30.0]	625 [38.0]	
Standard SAE B-Mount	1 1/4 Inch Straight	1 1/16 O-ring	109-1100	-1101	-1102	-1103	-1104	-1094	-1105	-1106	-1212	-1215
		3/4 inch Split Flange	109-1001	-1054	-1002	-1003	-1055	—	-1056	-1057	—	—
	1 5/8 Inch Tapered	1 1/16 O-ring	109-1107	-1108	-1109	-1110	-1111	—	-1112	-1113	-1479	-1455
		3/4 inch Split Flange	109-1006	-1058	-1007	-1008	-1059	—	-1402	-1061	—	—
	1 1/4 Inch 14 T Splined	1 1/16 O-ring	109-1114	-1115	-1116	-1117	-1118	—	-1119	-1120	—	—
		3/4 inch Split Flange	109-1011	-1062	-1012	-1013	-1063	—	-1064	-1065	—	—
Standard SAE C-Mount	40 mm Straight	G 3/4 (BSP)	109-1184	-1185	-1227	-1224	-1225	—	-1189	-1190	—	—
	1 1/4 Inch 17 T Splined	G 3/4 (BSP)	109-1191	-1192	-1193	-1194	-1195	—	-1196	-1197	—	—
Wheel Motor	1 1/4 Inch Straight	1 1/16 O-ring	110-1074	-1075	-1076	-1077	-1078	—	-1079	-1080	—	-1122
		3/4 inch Split Flange	110-1001	-1040	-1002	-1003	-1041	—	-1042	-1043	—	—
	40 mm Straight	G 3/4 (BSP)	110-1108	-1109	-1110	-1111	-1112	—	-1113	-1125	—	—
	1 5/8 Inch Tapered	1 1/16 O-ring	110-1081	-1082	-1083	-1084	-1085	—	-1086	-1087	1116	-1117
		3/4 inch Split Flange	110-1006	-1044	-1007	-1008	-1045	—	-1046	-1047	—	—
	1 1/4 Inch 14 T Splined	1 1/16 O-ring	110-1088	-1089	-1090	-1091	-1092	—	-1093	-1094	—	—
3/4 inch Split Flange		110-1011	-1048	-1012	-1013	-1049	—	-1050	-1051	—	—	
Bearingless	1 1/4 Inch Straight	1 1/16 O-ring	111-1033	-1034	-1035	-1036	-1037	—	-1038	-1039	-1062	-1063
		3/4 inch Split Flange	111-1044	-1015	-1045	-1046	-1016	—	-1017	-1018	—	—
	40 mm Straight	G 3/4 (BSP)	111-1052	-1053	-1054	-1055	-1056	—	-1057	-1058	—	—

* New Release

111-1057

4000 Series

Model Code

The following 30-digit coding system has been developed to identify all of the configuration options for the 4000 Series motor. Use this model code to specify a motor with the desired features. All 30 digits of the code must be present when ordering. You may want to photocopy the matrix below to ensure that each number is entered in the correct box.

M	0	4	*	*	*	*	*	*	*	*	*	*	*	*	*	*	*	*	*	*	*	*	*	*	*	*	*	*	
1	2	3	4	5	6	7	8	9	10	11	12	13	14	15	16	17	18	19	20	21	22	23	24	25	26	27	28	29	30

1 Product
M - Motor

2, **3** Series
04 - 4000 Series

4, **5**, **6** Displacement
cm³/r [in³/r]

067 - 109.8 cm³/r [6.70 in³/r]
080 - 130.3 cm³/r [7.95 in³/r]
099 - 162.2 cm³/r [9.90 in³/r]
125 - 205.5 cm³/r [12.54 in³/r]
150 - 246.3 cm³/r [15.03 in³/r]
 171 - 280.1 cm³/r [17.09 in³/r]
190 - 311.8 cm³/r [19.03 in³/r]
 225 - 369.0 cm³/r [22.52 in³/r]
240 - 393.9 cm³/r [24.04 in³/r]
301 - 492.6 cm³/r [30.06 in³/r]
 342 - 560.2 cm³/r [34.18 in³/r]
 381 - 623.9 cm³/r [38.07 in³/r]

7, **8** Mounting Type
AA - Bearingless, 4 Bolt: 127.00 [5.000] Pilot Dia. 14.27 [.562] Dia. Holes on 161.92 [6.375] Dia. Bolt Circle
AB - Standard, 4 Bolt: 101.60 [4.000] Pilot Dia. 14.7 [.58] Slots on 127.00 [5.000] Dia. Bolt Circle. (SAE B)
AC - Wheel, 4 Bolt: 139.70 [5.500] Pilot Dia. 14.27 [.562] Dia. Holes on 165.10 [6.500] Dia. Bolt Circle.

AD - Wheel, 4 Bolt: 127.00 [5.000] Pilot Dia. .500-13 UNC-2B Threaded Holes on 147.62 [5.812] Dia. Bolt circle.

AF - Standard, 4 Bolt: 127.00 [5.000] Pilot Dia. 14.27 [.562] Dia. Holes on 161.92 [6.375] Dia. Bolt Circle. (SAE C)

AH - Standard: ISO Flange 125 B4hw (ISO 3019/2) 124.97 [4.920] Pilot Dia. 14.27 [.562] Dia. Holes on 160.00 [6.299] Dia. Bolt Circle

AP - Wheel, 4 Bolt: 160.0 [6.30] Pilot Dia. with 5.8 [.23] Pilot Length and 18.00 [.709] Dia Holes on 200.00 [7.874] Bolt Circle (ISO Compatible)

9, **10** Output Shaft
00 - None (Bearingless)
01 - 31.75 [1.250] Dia. Straight With .375-16UNC-2B Thread, 53.1 [2.09] Max Coupling Length, 7.938 [.3125] Sq x 41.27 [1.625] Straight Key

02 - 41.28 [1.625] Dia. Tapered with 11.112 [.4375] Sq x 31.75 [1.250] Straight Key, 1.250-18UNEF-2A Thread with Slotted Hex Nut

03 - 31.75 [1.250] Dia. Flat Root Side Fit, 14 Tooth, 12/24 DP 30° Involute Spline, 38.1 [1.50] Minimum Full Spline Length with .375-16UNC-2B Thread

10 - 38.10 [1.500] Dia. Flat Root Side Fit, 17 Tooth, 12/24 DP 30°. Involute Spline, 31.2 [1.23] Minimum Full Spline Length, with .375-16 UNC-2B Thread in End

11 - 40.00 [1.575] Dia. Straight with M12 x 1.75-6H Thread, 7.955 [.3132] x 11.979 [.4716] Wide X 69.98 [2.755] Straight Key

21 - 40.00 [1.575] Dia. 10:1 Tapered Shaft per ISO R775 with .750-16 UNF-2B Threaded in End, 12W x 8H 70L [.472W x .313H x 2.76L] Key

22 - None (Bearingless) European Spline

25 - 42.00 [1.654] Dia. 10:1 Tapered Shaft per ISO R775 with .750-16 UNF-2B Thread in End, 12W x 8H X 63L [.472W X .313H X 2.48L] Key

11, **12** Ports
AA - .875-14 UNF-2B SAE O-Ring Ports - Staggered Ports

AB - 1.0625-12 UN-2B SAE O-Ring Ports - Staggered Ports

AC - G 3/4 Ports - Staggered Ports

AD - 19.05 [.750] 4 Bolt Split Flange Staggered Ports Standard Pressure Series (Code 61)

AE - M22 X 1.5-6H O-Ring Port - Staggered Ports

AG - 12.70 [.500] Dia. Manifold Ports

AJ - Dash 12 Stc Type II+ (Snap to Connect) Ports - Staggered Ports

13, **14** Case Flow Options
00 - None

01 - .5625-18 UNF-2B SAE O-Ring Port with Shuttle

02 - .4375-20 UNF-2B SAE O-ring Port with Check Valve

03 - G 1/4 BSP Straight Thread with Check Valve

06 - .4375-20 UNF-2B SAE O-ring Port with Reverse Flow Shuttle

10 - Dash 6 Stc Type II + (Snap to Connect) Port

15 Low Pressure Relief
0 - None

A - Set at 4.5 Bar [65 lbf/in²]

B - Set at 15.2 Bar [220 lbf/in²]

16, **17** Pressure/Flow Option
00 - None

18 Geroler Option
0 - Standard

19 Seal Option
0 - Standard
 1 - Viton
4 - Seal Guard

20, **21** Accessories
00 - None

AC - M 12 Threaded Connector, Long Body Digital Speed and Direction Pickup (Two 36 Pulse Signals in Quadrature per Revolution Pin 1=Power Supply, Pin 2=Output Signal 1, Pin 3=Common, Pin 4=Output Signal 2)

AD - M 12 Threaded Connector, Digital Speed And Direction Pickup (One 72 Pulse per Rev Speed Signal and One Directional Signal (Pin 1=Power, Pin 2=Direction, Pin 2=Common, Pin 4=Speed))

22, **23** Special Features (Hardware)
00 - None

17 - Low Noise Valve Plate

24, **25** Special Features (Assembly)
00 - None

26, **27** Paint/Packaging
00 - No Paint, Individual Box

AA - Painted Low Gloss Black, Individual Box
AB - Epoxy Coated (Frost Gray), Individual Box

28, **29** Customer Identification
00 - None

30 Design Code
F - Sixth

Feature in **bold** are preferred and allow for shorter lead time.