

**COUNTERBALANCE, STANDARD POPPET TYPE  
 DIFFERENTIAL AREA  
 SPECIAL CAVITY**

**VBSO-SEC-42**

**04.52.12 - X - 99 - Z**

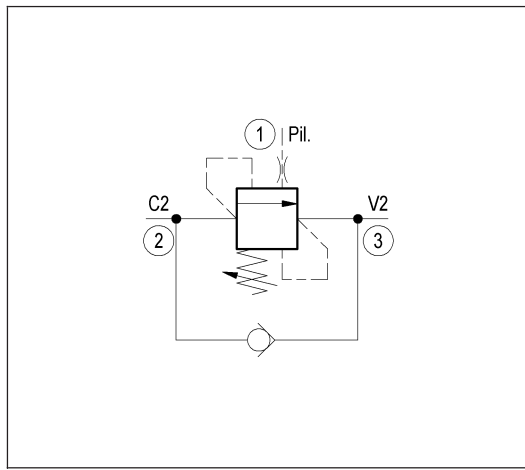
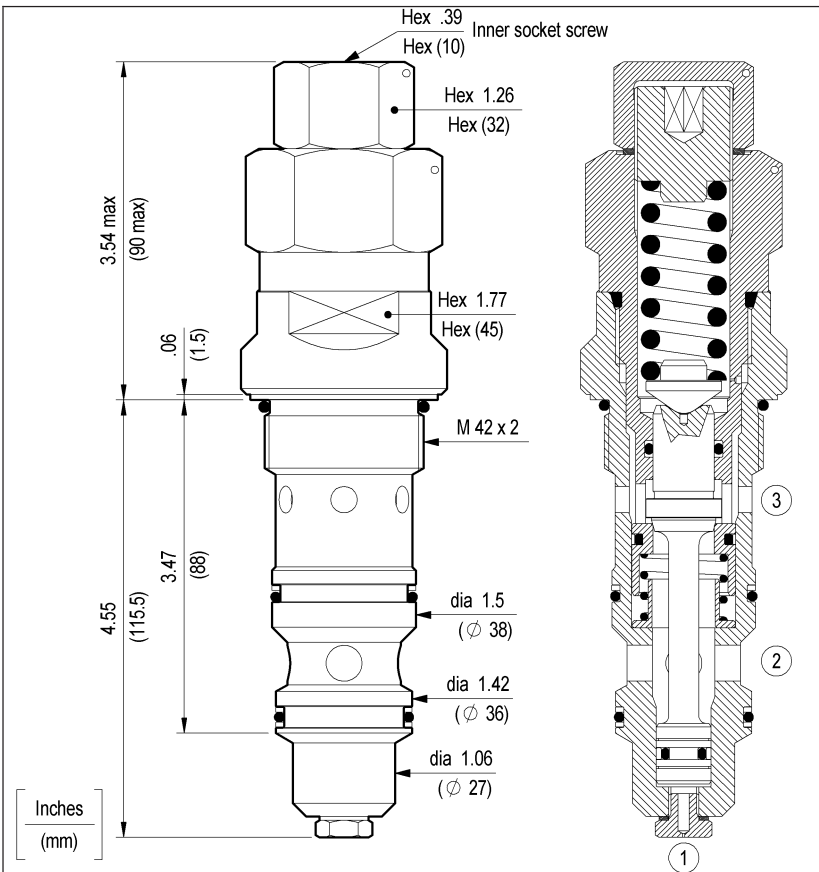

**TECHNICAL DATA**

Max. pressure:	5000 psi	(350 bar)
Max. flow:	79 gpm	(300 l/min)
Special cavity :	CD073A-01 (see page CT.S.005.U)	
Installation torque :	182-202 ft-lb	(246-272 Nm)
Weight:	3.087 lbs	(1.400 Kg)

When pressure at 3 rises above the spring bias pressure, the check seat is pushed away from the piston and flow is allowed from 3 to 2. When load pressure at 2 rises above the pressure setting, the direct-acting, differential area relief function is activated and flow is relieved from 2 to 3. With pilot pressure at 1, the pressure setting is reduced in proportion to the stated ratio of the valve, until fully open with free-flow from 2 to 3. The spring chamber is drained to 3, and any back-pressure at 3 is additive to the pressure setting in all functions.

Pressure setting: at least 1.3 times the load induced pressure

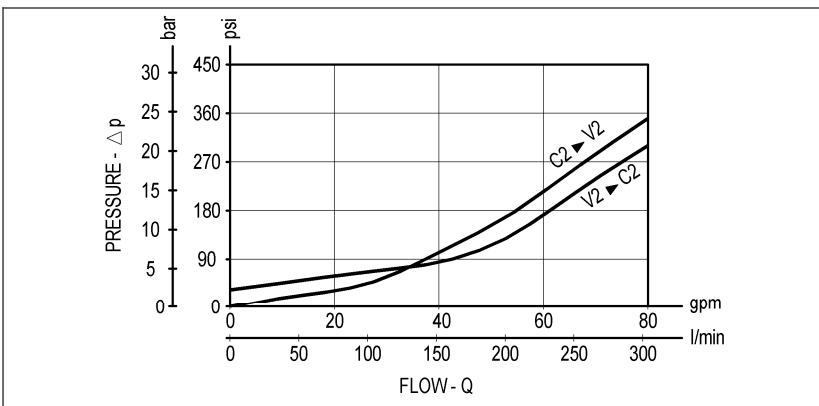

<b>X</b>	<b>PILOT RATIO</b>
<b>03</b>	4 : 1

<b>Z</b>	<b>SPRINGS</b>			
	Adj. press. range psi (bar)	Press. increase psi / turn (bar/turn)	Standard setting psi (bar) (Q=5 l/min)	
<b>35</b>	1450-5000 (100-350)	1059 (73)	5000 (350)	