

VSP-150

04.12.04 - X - 99 - Z

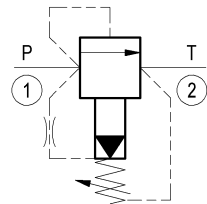
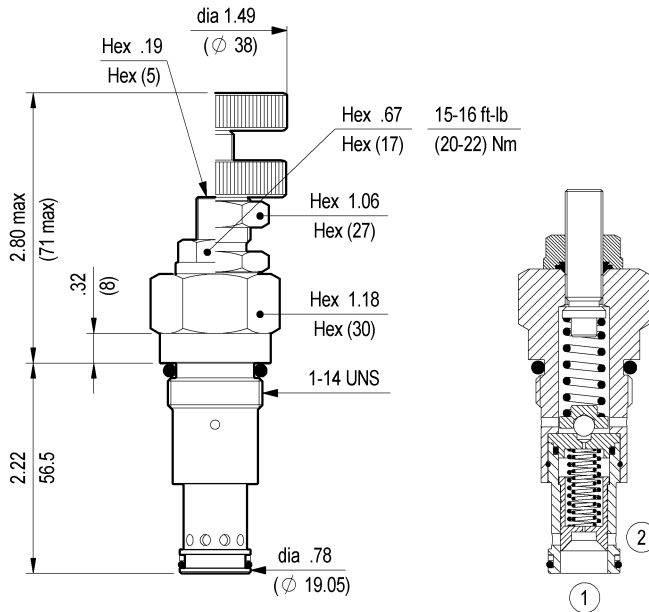

TECHNICAL DATA

Max. pressure:	6000 psi	(420 bar)
Max. flow:	40 gpm	(150 l/min)
Leakage at max relief setting ave. :	0.03 gpm	(0.10 l/min)
Special cavity :	065 (see page CT.S.002.U)	
Installation torque :	89-98 ft-lb	(121-133 Nm)
Weight:	0.617 lbs	(0.280 Kg)

Note: suitable for application where "T" line pressure never exceeds "P" line pressure.

Flow is blocked from 1 to 2 until pressure increases to meet the selected valve setting, lifting the pilot-stage ball check from its seat. This action exhausts oil above the main-stage piston (spool type), allowing it to shift and provide relief flow through 2 to tank. Pressure at 2 is additive to the relief setting of the valve.

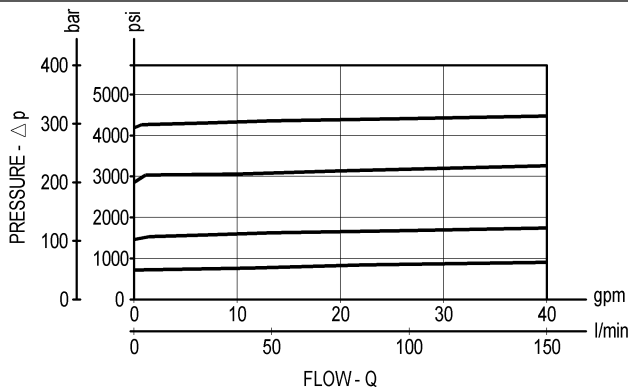

X ADJUSTMENTS

03	Leakproof hex. socket screw	
04	Handknob and locknut	

SPRINGS

Z	Adj. press. range psi (bar)	Press. increase psi / turn (bar/turn)	Standard setting psi (bar) (Q=5 l/min)
05	44-1000 (3-70)	290 (20)	725 (50)
10	100-1500 (7-105)	377 (26)	1450 (100)
20	145-3000 (10-210)	508 (35)	2900 (200)
40	500-6000 (35-420)	1668 (115)	5075 (350)

OPTIONS

Ordering code	Description
11.04.23.004	 Tamper resistant cap

Special settings available. Contact factory authorized representative for ordering code.