

460ml / 16oz (90mm) Art Series Double Wall BioCup BC-16DW-ART SERIES



*image as a guide only

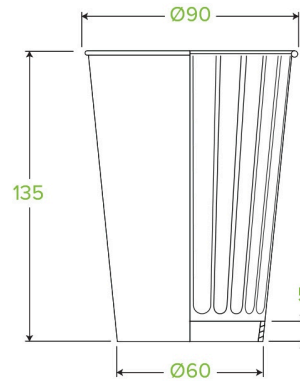

IMAGE AS A GUIDE ONLY. Cartons contain up to three different art cups with new artists featured every two months. Pictured here are designs from the latest Art Series. Unfortunately, we cannot sell individual art cups and cannot guarantee which prints, or which series of prints will be in each carton.

Carton quantity: 600	Sleeves per carton: 15	Units per sleeve: 40
Carton Size LxWxH (cm): 46.5x28.5x63	Carton gross weight (kg): 13.000000	Carton barcode: 19344062011504
Raw Material: Paper	Lining/coating: Bioplastic - Ingeo™ PLA	Window Material: None
Printing Type: Offset	Inks: Food Contact Safe Inks	Brim fill capacity (ml): 464
Dimensions top LxW (mm): 90x90	Dimensions base LxW (mm): 60x60	Product Depth: 136
Product weight (g): 22	Thickness: 285gsm + 35gsm PLA	Use: Hot and cold
Manufactured: Taiwan	Customise: Print	MOQ custom: 50000
Mould fees: No	Quality product certified: ISO 9001	Factory food safety certified: BRC, HACCP
Home compostable: No	Industrially compostable: Certified to AS4736 Australian Standards, Certified to EN13432 European Standard	Recyclable: No