

# 16xPDIF

16-CHANNEL DIFFERENTIAL PRESSURE SENSOR FOR CAN BUS

Ref :

SN: Software version :

Texys sensors are designed for data recording. If the user wants to include this sensor in a close loop system or active control, he must assume all responsibility.

Range	+/- 50 to +/- 1000 +/- 0.7 to +/- 15	mBar PSI
Sensitive Element	Piezo resistive Cells	
Accuracy at FS	+/- 0.5	% FS
Non linearity/ Hysteresis	+/- 0.7	% FS
Offset Drift	+/- 0.5	% FS
Sensitivity drift	0.5	%
Sampling Frequency SF	200	Hz
Autozero	<input type="checkbox"/> available <input type="checkbox"/> not available	
CAN bus2.0 A or B	120Ω : <input type="checkbox"/> yes <input checked="" type="checkbox"/> no	
Output Data	Calibrated Pressure : 2 bytes per channel (signed int)	
Unit	1	mPSI/bit
	0.1	mBar/bit
Parameters	Identifiers, Baud rate, Frequency, Unit /Resolution	
Baud rate	125k to 1Mbps	
Data Frequency	1 to 200	Hz
	or on trigger	
Supply Voltage	6 to 16	V
Supply Current	30	mA
Calibrator	Height of water	
Dimensions	100 x 28 x 24	mm
Material	Aluminum	
Weight (without cable)	TBD	g
Protection	IP64	
Vibration test	20Gpp 5'	
Shock	500	G
Operating Temp	+5 to +85	°C
Storage Temp	-40 to +125	°C

This sensor withstands high humidity. Avoid water entering in the tube as well as condensation, it may block the pressure.  
Do not blow into the tubes with the mouth or a compressed air line

option manifold  
1x 16 lane

## Ordering reference:

16xPDIF - range - option -

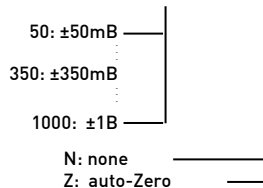

Sensor Readings			
Channel	at mBar	at 0 mBar	at mBar
1			
2			
3			
4			
5			
6			
7			
8			
9			
10			
11			
12			
13			
14			
15			
16			

Setup parameters			
CAN	2.0A	2.0B	-
Baudrate	1		Mbps
Frequency	10		Hz
Rx trig ID	7F0		Hex
Tx1 ID	3F0		Hex
Tx2 ID	3F4		Hex
Tx3 ID	3F8		Hex
Tx4 ID	3FB		Hex
Unit	0.1mBar/bit	0.001PSI/bit	-

Connector : 8STA00406PN

Mating connector : 8STA60406SN

PIN	Function
1	Supply
2	0 V
3	CAN Low
4	CAN High
5	Reserved, do not connect
6	Reserved, do not connect

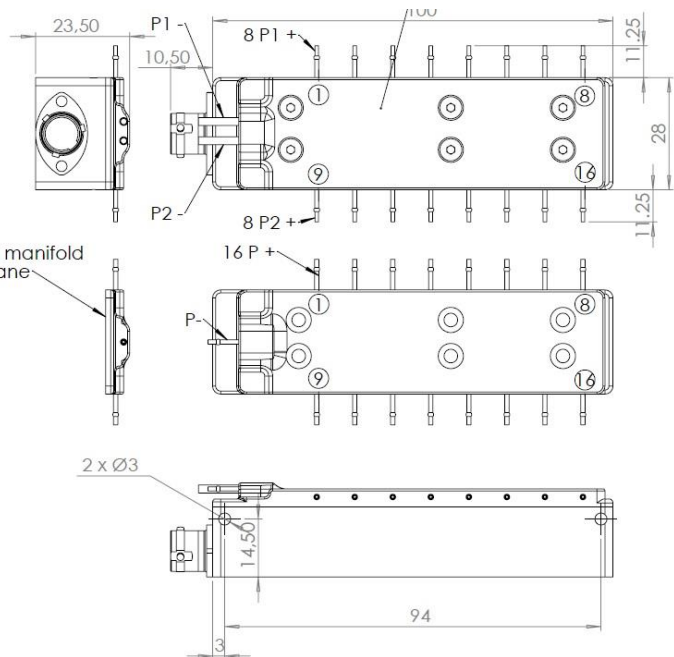

## CAN overview

### Data output

Frame #1 (default Tx1 Frame ID: 0x03F0)

ID	Byte 0	Byte 1	Byte 2	Byte 3	Byte 4	Byte 5	Byte 6	Byte 7
0x03F0	Channel 1 MSB	Channel 1 LSB	Channel 2 MSB	Channel 2 LSB	Channel 3 MSB	Channel 3 LSB	Channel 4 MSB	Channel 4 LSB
	Pressure 1		Pressure 2		Pressure 3		Pressure 4	

Frame #2 (default Tx2 Frame ID: 0x03F4)

ID	Byte 0	Byte 1	Byte 2	Byte 3	Byte 4	Byte 5	Byte 6	Byte 7
0x03F4	Channel 5 MSB	Channel 5 LSB	Channel 6 MSB	Channel 6 LSB	Channel 7 MSB	Channel 7 LSB	Channel 8 MSB	Channel 8 LSB
	Pressure 5		Pressure 6		Pressure 7		Pressure 8	

Frame #3 (default Tx3 Frame ID: 0x03F8)

ID	Byte 0	Byte 1	Byte 2	Byte 3	Byte 4	Byte 5	Byte 6	Byte 7
0x03F8	Channel 9 MSB	Channel 9 LSB	Channel 10 MSB	Channel 10 LSB	Channel 11 MSB	Channel 11 LSB	Channel 12 MSB	Channel 12 LSB
	Pressure 9		Pressure 10		Pressure 11		Pressure 12	

Frame #4 (default Tx4 Frame ID: 0x03FB)

ID	Byte 0	Byte 1	Byte 2	Byte 3	Byte 4	Byte 5	Byte 6	Byte 7
0x03FB	Channel 13 MSB	Channel 13 LSB	Channel 14 MSB	Channel 14 LSB	Channel 15 MSB	Channel 15 LSB	Channel 16 MSB	Channel 16 LSB
	Pressure 13		Pressure 14		Pressure 15		Pressure 16	

### Input command

Auto-zero (optional)

ID	Byte 0	Byte 1	Byte 2	Byte 3	Byte 4	Byte 5	Byte 6	Byte 7
0x07F1	0xFF	-	-	-	-	-	-	0x01

This command can be used to re-zero all channels. Each time the sensor will receive the above CAN frame, the autozero function will be launched (except during first second after power-on). When autozero function is launched, a "customer offset" is set up and added for each channel on top of factory calibration. Those "Customer offsets" will be stored in volatile memory. Therefore, they will be lost when switching OFF the sensor and they will be initialized to 0 when switching ON the sensor.

## Changing parameters

Must be setup according to Texense's CAN protocol, or by using the Texense Android Smart Tool (tAST®) with your android device. Contact us at [info@texense.com](mailto:info@texense.com)

CAN parameters:

N°	Parameter	Raw values	values	Comments
0x00	Baudrate	0x00	CAN2.0A 1Mbps	Default
		0x01	CAN2.0A 500 Kbps	
		0x02	CAN2.0A 250 Kbps	
		0x03	CAN2.0A 125 Kbps	
		0x10	CAN2.0B 1Mbps	
		0x11	CAN2.0B 500 Kbps	
		0x12	CAN2.0B 250 Kbps	
		0x13	CAN2.0B 125 Kbps	
0x01	Emission frequency	0x00	Rx frame trig	On request - 10Hz max.
		0x01	1 Hz	
		0x02	5	
		0x03	10	Default
		0x04	50	
		0x05	100	
		0x06	200	
0x02	Rx frame ID	if CAN2.0A: 0x1 to 0x7F0		MSB
0x03		if CAN2.0B: 0x1 to 0xFFFF (except 0x7F1 to 0x7F3)		LSB
0x04	Tx1 frame ID	if CAN2.0A: 0x1 to 0x7F0		MSB
0x05		if CAN2.0B: 0x1 to 0xFFFF (except 0x7F1 to 0x7F3)		LSB
0x06	Tx2 frame ID	if CAN2.0A: 0x1 to 0x7F0		MSB
0x07		if CAN2.0B: 0x1 to 0xFFFF (except 0x7F1 to 0x7F3)		LSB
0x08	Unit	0x00	PSI	0.001 PSI / bit
		0x01	Bars	0.1 mBar / bit
0x09	Tx3 frame ID	if CAN2.0A: 0 to 0x7F0		MSB
0x0A		if CAN2.0B: 0 to 0xFFFF		LSB
0x0B	Tx4 frame ID	if CAN2.0A: 0 to 0x7F0		MSB
0x0C		if CAN2.0B: 0 to 0xFFFF		LSB