

# RaceGrade

<b>Document Number</b>		RG_SPEC-xxxx	
<b>Title</b>		RaceGrade APT-KM42 Pressure Transducer	
<b>Revision</b>	<b>Date</b>	<b>Prepared By</b>	<b>Change History</b>
0.1	5/23/14	Hannah Westbrook	Initial release

## Introduction

This APT-KM42-2000 Pressure Transducer produces a DC voltage proportional to the pressure reading. It provides accurate and repeatable sensor readings by accounting for the effects of temperature, hysteresis and non-linearity. Featuring a wetted stainless steel design, it is compatible with all fluids and is hermetically sealed with an IP 67 ingress rating. It comes with a 3/8-24UNF-2A with O-ring as the pressure port, and an AS4H06-05PN-HE 5 pin Autosport connector. Multiple pressure ranges are available.

<b>Part #</b>	<b>Range</b>
APT-KM-42-150	150 PSI Gauge
APT-KM-42-2000	2000 PSI Gauge

## Calibration:

0.5v = 0 PSI

4.5v = Full scale pressure

## Specifications:

- Fitting: 3/8-24UNF-2A
- Output: 0.5 to 4.5 Vdc
- Supply: 5 +/- 0.5 Vdc
- Current: < 4 mA
- Temperature Range: -40°C to 125°C
- Total Error: 1.0 % of F.S. Pres
- Proof Pressure: 2 x F.S Pres
- Burst Pressure: 5 X F.S. Pres
- Response time : < 1 ms
- Main Seal: Welded Stainless
- Weight: 46 grams
- Random Vibration : 20g

## Connection:

Mating connector:

pin 1 – 0v

pin 2 – N/C

pin 3 – Signal

pin 4 – N/C

pin 5 – 5v

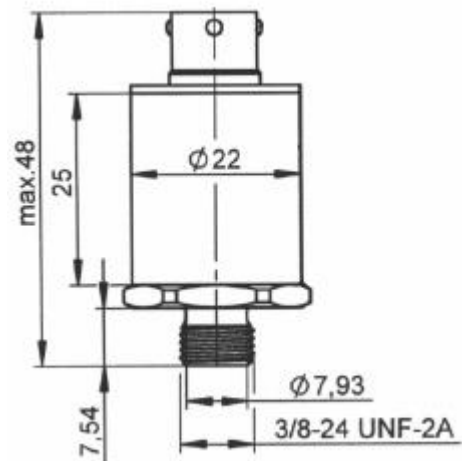

Note: Sensor should be mounted remotely to avoid engine vibration damage.